

---

**INSTRUCTOR'S  
MANUAL FOR**

**ADVANCED  
ENGINEERING  
MATHEMATICS**

---

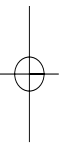

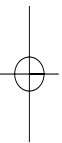
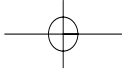

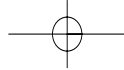

---

# INSTRUCTOR'S MANUAL FOR

# ADVANCED ENGINEERING MATHEMATICS

---

## NINTH EDITION

---

## ERWIN KREYSZIG

Professor of Mathematics  
Ohio State University  
Columbus, Ohio



JOHN WILEY & SONS, INC.

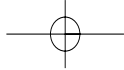

*Vice President and Publisher:* Laurie Rosatone  
*Editorial Assistant:* Daniel Grace  
*Associate Production Director:* Lucille Buonocore  
*Senior Production Editor:* Ken Santor  
*Media Editor:* Stefanie Liebman  
*Cover Designer:* Madelyn Lesure  
*Cover Photo:* © John Sohm/Chromosohm/Photo Researchers

This book was set in Times Roman by GGS Information Services and printed and bound by Hamilton Printing. The cover was printed by Hamilton Printing.

This book is printed on acid free paper. ™

Copyright © 2006 by John Wiley & Sons, Inc. All rights reserved.

No part of this publication may be reproduced, stored in a retrieval system or transmitted in any form or by any means, electronic, mechanical, photocopying, recording, scanning or otherwise, except as permitted under Sections 107 or 108 of the 1976 United States Copyright Act, without either the prior written permission of the Publisher, or authorization through payment of the appropriate per-copy fee to the Copyright Clearance Center, 222 Rosewood Drive, Danvers, MA 01923, (508) 750-8400, fax (508) 750-4470. Requests to the Publisher for permission should be addressed to the Permissions Department, John Wiley & Sons, Inc., 111 River Street, Hoboken, NJ 07030, (201) 748-6011, fax (201) 748-6008, E-Mail: PERMREQ@WILEY.COM.

ISBN-13: 978-0-471-72647-0  
ISBN-10: 0471-72647-8

Printed in the United States of America

10 9 8 7 6 5 4 3 2 1



# PREFACE

## General Character and Purpose of the Instructor's Manual

This Manual contains:

- (I) Detailed solutions of the even-numbered problems.
- (II) General comments on the purpose of each section and its classroom use, with mathematical and didactic information on teaching practice and pedagogical aspects. Some of the comments refer to whole chapters (and are indicated accordingly).

## Changes in Problem Sets

The major changes in this edition of the text are listed and explained in the Preface of the book. They include global improvements produced by updating and streamlining chapters as well as many local improvements aimed at **simplification** of the whole text. Speedy orientation is helped by chapter summaries at the end of each chapter, as in the last edition, and by the subdivision of sections into subsections with unnumbered headings. Resulting effects of these changes on the problem sets are as follows.

*The problems have been changed.* The large total number of *more than 4000 problems* has been retained, increasing their overall usefulness by the following:

- Placing more emphasis on **modeling** and **conceptual thinking** and less emphasis on technicalities, to parallel recent and ongoing developments in calculus.
- **Balancing** by extending problem sets that seemed too short and contracting others that were too long, **adjusting the length to the relative importance of the material in a section**, so that important issues are reflected sufficiently well not only in the text but also in the problems. Thus, the danger of overemphasizing minor techniques and ideas is avoided as much as possible.
- **Simplification** by omitting a small number of very difficult problems that appeared in the previous edition, retaining the wide spectrum ranging from simple routine problems to more sophisticated engineering applications, and taking into account the “*algorithmic thinking*” that is developing along with computers.
- **Amalgamation** of text, examples, and problems by including the **large number of more than 600 worked-out examples in the text** and by providing problems closely related to those examples.
- Addition of **TEAM PROJECTS, CAS PROJECTS, and WRITING PROJECTS**, whose role is explained in the Preface of the book.
- Addition of **CAS EXPERIMENTS**, that is, the use of the computer in “**experimental mathematics**” for experimentation, discovery, and research, which often produces unexpected results for open-ended problems, deeper insights, and relations among practical problems.

These changes in the problem sets will help students in solving problems as well as in gaining a better understanding of practical aspects in the text. It will also enable instructors to explain ideas and methods in terms of examples supplementing and illustrating theoretical discussions—or even replacing some of them if so desired.

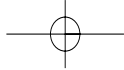
**“Show the details of your work.”**

This request repeatedly stated in the book applies to all the problem sets. Of course, it is intended to prevent the student from simply producing answers by a CAS instead of trying to understand the underlying mathematics.

**Orientation on Computers**

Comments on computer use are included in the Preface of the book. Software systems are listed in the book at the beginning of Chap. 19 on numeric analysis and at the beginning of Chap. 24 on probability theory.

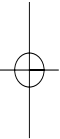
**ERWIN KREYSZIG**

# Part A. ORDINARY DIFFERENTIAL EQUATIONS (ODEs)

## CHAPTER 1 First-Order ODEs

### Major Changes

There is more material on modeling in the text as well as in the problem set.

Some additions on population dynamics appear in Sec. 1.5.

Electric circuits are shifted to Chap. 2, where second-order ODEs will be available. This avoids repetitions that are unnecessary and practically irrelevant.

Team Projects, CAS Projects, and CAS Experiments are included in most problem sets.

### SECTION 1.1. Basic Concepts. Modeling, page 2

**Purpose.** To give the students a first impression what an ODE is and what we mean by solving it.

**Background Material.** For the whole chapter we need integration formulas and techniques, which the student should review.

#### General Comments

This section should be covered relatively rapidly to get quickly to the actual solution methods in the next sections.

Equations (1)–(3) are just examples, not for solution, but the student will see that solutions of (1) and (2) can be found by calculus, and a solution  $y = e^x$  of (3) by inspection.

**Problem Set 1.1** will help the student with the tasks of

Solving  $y' = f(x)$  by calculus

Finding particular solutions from given general solutions

Setting up an ODE for a given function as solution

Gaining a first experience in modeling, by doing one or two problems

Gaining a first impression of the importance of ODEs

without wasting time on matters that can be done much faster, once systematic methods are available.

#### Comment on “General Solution” and “Singular Solution”

Usage of the term “general solution” is not uniform in the literature. Some books use the term to mean a solution that includes *all* solutions, that is, both the particular and the singular ones. We do not adopt this definition for two reasons. First, it is frequently quite difficult to prove that a formula includes *all* solutions; hence, this definition of a general solution is rather useless in practice. Second, *linear* differential equations (satisfying rather general conditions on the coefficients) have no singular solutions (as mentioned in the text), so that for these equations a general solution as defined does include all solutions. For the latter reason, some books use the term “general solution” for linear equations only; but this seems very unfortunate.

**SOLUTIONS TO PROBLEM SET 1.1, page 8**

2.  $y = -e^{-3x}/3 + c$     4.  $y = (\sinh 4x)/4 + c$

6. Second order.    8. First order.

10.  $y = ce^{0.5x}$ ,  $y(2) = ce = 2$ ,  $c = 2/e$ ,  $y = (2/e)e^{0.5x} = 0.736e^{0.5x}$

12.  $y = ce^x + x + 1$ ,  $y(0) = c + 1 = 3$ ,  $c = 2$ ,  $y = 2e^x + x + 1$

14.  $y = c \sec x$ ,  $y(0) = c/\cos 0 = c = \frac{1}{2}\pi$ ,  $y = \frac{1}{2}\pi \sec x$

16. Substitution of  $y = cx - c^2$  into the ODE gives

$$y'^2 - xy' + y = c^2 - xc + (cx - c^2) = 0.$$

Similarly,

$$y = \frac{1}{4}x^2, \quad y' = \frac{1}{2}x, \quad \text{thus} \quad \frac{1}{4}x^2 - x(\frac{1}{2}x) + \frac{1}{4}x^2 = 0.$$

18. In Prob. 17 the constants of integration were set to zero. Here, by two integrations,

$$y'' = g, \quad v = y' = gt + c_1, \quad y = \frac{1}{2}gt^2 + c_1t + c_2, \quad y(0) = c_2 = y_0,$$

and, furthermore,

$$v(0) = c_1 = v_0, \quad \text{hence} \quad y = \frac{1}{2}gt^2 + v_0t + y_0,$$

as claimed. Times of fall are 4.5 and 6.4 sec, from  $t = \sqrt{100/4.9}$  and  $\sqrt{200/4.9}$ .20.  $y' = ky$ . Solution  $y = y_0 e^{kx}$ , where  $y_0$  is the pressure at sea level  $x = 0$ . Now  $y(18000) = y_0 e^{k \cdot 18000} = \frac{1}{2}y_0$  (given). From this,

$$e^{k \cdot 18000} = \frac{1}{2}, \quad y(36000) = y_0 e^{k \cdot 2 \cdot 18000} = y_0 (e^{k \cdot 18000})^2 = y_0 (\frac{1}{2})^2 = \frac{1}{4}y_0.$$

22. For 1 year and annual, daily, and continuous compounding we obtain the values

$$y_a(1) = 1060.00, \quad y_d(1) = 1000(1 + 0.06/365)^{365} = 1061.83,$$

$$y_c(1) = 1000e^{0.06} = 1061.84,$$

respectively. Similarly for 5 years,

$$y_a(5) = 1000 \cdot 1.06^5 = 1338.23, \quad y_d(5) = 1000(1 + 0.06/365)^{365 \cdot 5} = 1349.83,$$

$$y_c(5) = 1000e^{0.06 \cdot 5} = 1349.86.$$

We see that the difference between daily compounding and continuous compounding is very small.

The ODE for continuous compounding is  $y'_c = ry_c$ .**SECTION 1.2. Geometric Meaning of  $y' = f(x, y)$ . Direction Fields, page 9**

**Purpose.** To give the student a feel for the nature of ODEs and the general behavior of fields of solutions. This amounts to a conceptual clarification before entering into formal manipulations of solution methods, the latter being restricted to relatively small—albeit important—classes of ODEs. This approach is becoming increasingly important, especially because of the graphical power of **computer software**. It is the analog of conceptual studies of the derivative and integral in calculus as opposed to formal techniques of differentiation and integration.

**Comment on Isoclines**

These could be omitted because students sometimes confuse them with solutions. In the computer approach to direction fields they no longer play a role.

**Comment on Order of Sections**

This section could equally well be presented later in Chap. 1, perhaps after one or two formal methods of solution have been studied.

**SOLUTIONS TO PROBLEM SET 1.2, page 11**

2. Semi-ellipse  $x^2/4 + y^2/9 = 13/9$ ,  $y > 0$ . To graph it, choose the  $y$ -interval large enough, at least  $0 \leq y \leq 4$ .
4. Logistic equation (Verhulst equation; Sec. 1.5). Constant solutions  $y = 0$  and  $y = \frac{1}{2}$ . For these,  $y' = 0$ . Increasing solutions for  $0 < y(0) < \frac{1}{2}$ , decreasing for  $y(0) > \frac{1}{2}$ .
6. The solution (not of interest for doing the problem) is obtained by using

$$dy/dx = 1/(dx/dy) \quad \text{and solving} \quad dx/dy = 1/(1 + \sin y) \quad \text{by integration,}$$

$$x + c = -2/(\tan \frac{1}{2}y + 1); \quad \text{thus} \quad y = -2 \arctan ((x + 2 + c)/(x + c)).$$

8. Linear ODE. The solution involves the error function.
12. By integration,  $y = c - 1/x$ .
16. The solution (not needed for doing the problem) of  $y' = 1/y$  can be obtained by separating variables and using the initial condition;  $y^2/2 = t + c$ ,  $y = \sqrt{2t - 1}$ .
18. The solution of this initial value problem involving the linear ODE  $y' + y = t^2$  is  $y = 4e^{-t} + t^2 - 2t + 2$ .
20. **CAS Project.** (a) Verify by substitution that the general solution is  $y = 1 + ce^{-x}$ . Limit  $y = 1$  ( $y(x) = 1$  for all  $x$ ), increasing for  $y(0) < 1$ , decreasing for  $y(0) > 1$ .  
 (b) Verify by substitution that the general solution is  $x^4 + y^4 = c$ . More "square-shaped," isoclines  $y = kx$ . Without the minus on the right you get "hyperbola-like" curves  $y^4 - x^4 = \text{const}$  as solutions (verify!). The direction fields should turn out in perfect shape.  
 (c) The computer may be better if the isoclines are complicated; but the computer may give you nonsense even in simpler cases, for instance when  $y(x)$  becomes imaginary. Much will depend on the choice of  $x$ - and  $y$ -intervals, a method of trial and error. Isoclines may be preferable if the explicit form of the ODE contains roots on the right.

**SECTION 1.3. Separable ODEs. Modeling, page 12**

**Purpose.** To familiarize the student with the first "big" method of solving ODEs, the separation of variables, and an extension of it, the reduction to separable form by a transformation of the ODE, namely, by introducing a new unknown function.

The section includes standard applications that lead to separable ODEs, namely,

1. the ODE giving  $\tan x$  as solution
2. the ODE of the exponential function, having various applications, such as in radiocarbon dating
3. a mixing problem for a single tank
4. Newton's law of cooling
5. Torricelli's law of outflow.

In reducing to separability we consider

6. the transformation  $u = y/x$ , giving perhaps the most important reducible class of ODEs.

Ince's classical book [A11] contains many further reductions as well as a systematic theory of reduction for certain classes of ODEs.

#### Comment on Problem 5

From the implicit solution we can get two explicit solutions

$$y = +\sqrt{c - (6x)^2}$$

representing semi-ellipses in the upper half-plane, and

$$y = -\sqrt{c - (6x)^2}$$

representing semi-ellipses in the lower half-plane. [Similarly, we can get two explicit solutions  $x(y)$  representing semi-ellipses in the left and right half-planes, respectively.] On the  $x$ -axis, the tangents to the ellipses are vertical, so that  $y'(x)$  does not exist. Similarly for  $x'(y)$  on the  $y$ -axis.

This also illustrates that it is natural to consider solutions of ODEs on *open* rather than on *closed* intervals.

#### Comment on Separability

An analytic function  $f(x, y)$  in a domain  $D$  of the  $xy$ -plane can be factored in  $D$ ,  $f(x, y) = g(x)h(y)$ , if and only if in  $D$ ,

$$f_{xy}f = f_x f_y$$

[D. Scott, *American Math. Monthly* **92** (1985), 422–423]. Simple cases are easy to decide, but this may save time in cases of more complicated ODEs, some of which may perhaps be of practical interest. You may perhaps ask your students to derive such a criterion.

#### Comments on Application

Each of those examples can be modified in various ways, for example, by changing the application or by taking another form of the tank, so that each example characterizes a whole class of applications.

The many ODEs in the problem set, much more than one would ordinarily be willing and have the time to consider, should serve to convince the student of the practical importance of ODEs; so these are ODEs to choose from, depending on the students' interest and background.

#### Comment on Footnote 3

Newton conceived his method of fluxions (calculus) in 1665–1666, at the age of 22. *Philosophiae Naturalis Principia Mathematica* was his most influential work.

Leibniz invented calculus independently in 1675 and introduced notations that were essential to the rapid development in this field. His first publication on differential calculus appeared in 1684.

### SOLUTIONS TO PROBLEM SET 1.3, page 18

2.  $dy/y^2 = -(x + 2)dx$ . The variables are now separated. Integration on both sides gives

$$-\frac{1}{y} = -\frac{1}{2}x^2 - 2x + c^*. \quad \text{Hence} \quad y = \frac{2}{x^2 + 4x + c}.$$

4. Set  $y + 9x = v$ . Then  $y = v - 9x$ . By substitution into the given ODE you obtain

$$y' = v' - 9 = v^2. \quad \text{By separation,} \quad \frac{dv}{v^2 + 9} = dx.$$

Integration gives

$$\frac{1}{3} \arctan \frac{v}{3} = x + c^*, \quad \arctan \frac{v}{3} = 3x + c$$

and from this and substitution of  $y = v - 9x$ ,

$$v = 3 \tan(3x + c), \quad y = 3 \tan(3x + c) - 9x.$$

6. Set  $u = y/x$ . Then  $y = xu$ ,  $y' = u + xu'$ . Substitution into the ODE and subtraction of  $u$  on both sides gives

$$y' = \frac{4x}{y} + \frac{y}{x} = u + xu' = \frac{4}{u} + u, \quad xu' = \frac{4}{u}.$$

Separation of variables and replacement of  $u$  with  $y/x$  yields

$$2u \, du = \frac{8}{x} \, dx, \quad u^2 = 8 \ln|x| + c, \quad y^2 = x^2(8 \ln|x| + c).$$

8.  $u = y/x$ ,  $y = xu$ ,  $y' = u + xu'$ . Substitute  $u$  into the ODE, drop  $xu$  on both sides, and divide by  $x^2$  to get

$$xy' = xu + x^2u' = \frac{1}{2}x^2u^2 + xu, \quad u' = \frac{1}{2}u^2.$$

Separate variables, integrate, and solve algebraically for  $u$ :

$$\frac{du}{u^2} = \frac{1}{2} \, dx, \quad -\frac{1}{u} = \frac{1}{2}(x + c^*), \quad u = \frac{2}{c - x}.$$

Hence

$$y = xu = \frac{2x}{c - x}.$$

10. By separation,  $y \, dy = -4x \, dx$ . By integration,  $y^2 = -4x^2 + c$ . The initial condition  $y(0) = 3$ , applied to the last equation, gives  $9 = 0 + c$ . Hence  $y^2 + 4x^2 = 9$ .
12. Set  $u = y/x$ . Then  $y' = u + xu'$ . Divide the given ODE by  $x^2$  and substitute  $u$  and  $u'$  into the resulting equation. This gives

$$2u(u + xu') = 3u^2 + 1.$$

Subtract  $2u^2$  on both sides and separate the variables. This gives

$$2xuu' = u^2 + 1, \quad \frac{2u \, du}{u^2 + 1} = \frac{dx}{x}.$$

Integrate, take exponents, and then take the square root:

$$\ln(u^2 + 1) = \ln|x| + c^*, \quad u^2 + 1 = cx, \quad u = \pm\sqrt{cx - 1}.$$

Hence

$$y = xu = \pm x\sqrt{cx - 1}.$$

From this and the initial condition,  $y(1) = \sqrt{c - 1} = 2$ ,  $c = 5$ . This gives the *answer*  
 $y = x\sqrt{5x - 1}$ .

14. Set  $u = y/x$ . Then  $y = xu$ ,  $y' = u + xu'$ . Substitute this into the ODE, subtract  $u$  on both sides, simplify algebraically, and integrate:

$$xu' = \frac{2x^2}{u} \cos(x^2) \quad uu' = 2x \cos(x^2), \quad u^2/2 = \sin(x^2) + c.$$

Hence  $y^2 = 2x^2(\sin(x^2) + c)$ . By the initial condition,  $\pi = \pi(\sin \frac{1}{2}\pi + c)$ ,  $c = 0$ ,

$$y = xu = x\sqrt{2 \sin(x^2)}.$$

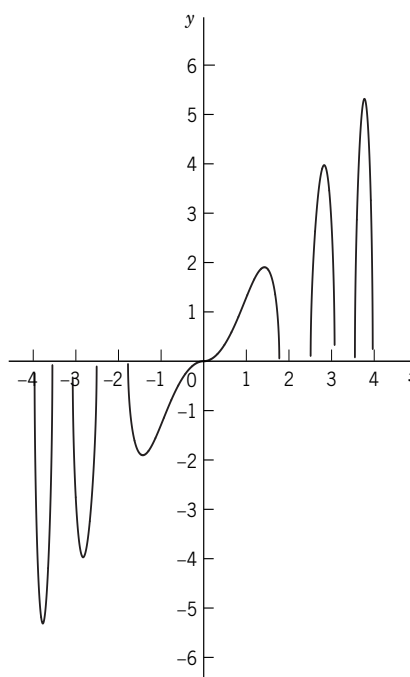

**Problem Set 1.3.** Problem 14. First five real branches of the solution

16.  $u = y/x$ ,  $y = xu$ ,  $y' = u + xu' = u + 4x^4 \cos^2 u$ . Simplify, separate variables, and integrate:

$$u' = 4x^3 \cos^2 u, \quad du/\cos^2 u = 4x^3 dx, \quad \tan u = x^4 + c.$$

Hence

$$y = xu = x \arctan(x^4 + c).$$

From the initial condition,  $y(2) = 2 \arctan(16 + c) = 0$ ,  $c = -16$ . *Answer:*

$$y = x \arctan(x^4 - 16).$$

18. Order terms:

$$\frac{dr}{d\theta} (1 - b \cos \theta) = br \sin \theta.$$

Separate variables and integrate:

$$\frac{dr}{r} = \frac{b \sin \theta}{1 - b \cos \theta} d\theta, \quad \ln r = \ln(1 - b \cos \theta) + c^*.$$



Take exponents and use the initial condition:

$$r = c(1 - b \cos \theta), \quad r\left(\frac{\pi}{2}\right) = c(1 - b \cdot 0) = \pi, \quad c = \pi.$$

Hence the *answer* is  $r = \pi(1 - b \cos \theta)$ .

20. On the left, integrate  $g(w)$  over  $w$  from  $y_0$  to  $y$ . On the right, integrate  $f(t)$  over  $t$  from  $x_0$  to  $x$ . In Prob. 19,

$$\int_1^y w e^{w^2} dw = \int_0^x (t - 1) dt.$$

22. Consider any straight line  $y = ax$  through the origin. Its slope is  $y/x = a$ . The slope of a solution curve at a point of intersection  $(x, ax)$  is  $y' = g(y/x) = g(a) = \text{const}$ , independent of the point  $(x, y)$  on the straight line considered.
24. Let  $k_B$  and  $k_D$  be the constants of proportionality for the birth rate and death rate, respectively. Then  $y' = k_B y - k_D y$ , where  $y(t)$  is the population at time  $t$ . By separating variables, integrating, and taking exponents,

$$dy/y = (k_B - k_D) dt, \quad \ln y = (k_B - k_D)t + c^*, \quad y = ce^{(k_B - k_D)t}.$$

26. The model is  $y' = -Ay \ln y$  with  $A > 0$ . Constant solutions are obtained from  $y' = 0$  when  $y = 0$  and 1. Between 0 and 1 the right side is positive (since  $\ln y < 0$ ), so that the solutions grow. For  $y > 1$  we have  $\ln y > 0$ ; hence the right side is negative, so that the solutions decrease with increasing  $t$ . It follows that  $y = 1$  is stable. The general solution is obtained by separation of variables, integration, and two subsequent exponentiations:

$$\begin{aligned} dy/(y \ln y) &= -A dt, & \ln(\ln y) &= -At + c^*, \\ \ln y &= ce^{-At}, & y &= \exp(ce^{-At}). \end{aligned}$$

28. The temperature of the water is decreasing exponentially according to Newton's law of cooling. The decrease during the first 30 min, call it  $d_1$ , is greater than that,  $d_2$ , during the next 30 min. Thus  $d_1 > d_2 = 190 - 110 = 80$  as measured. Hence the temperature at the beginning of parking, if it had been 30 min earlier, before the arrest, would have been greater than  $190 + 80 = 270$ , which is impossible. Therefore Jack has no alibi.
30. The cross-sectional area  $A$  of the hole is multiplied by 4. In the particular solution,  $15.00 - 0.000332t$  is changed to  $15.00 - 4 \cdot 0.000332t$  because the second term contains  $A/B$ . This changes the time  $t = 15.00/0.000332$  when the tank is empty, to  $t = 15.00/(4 \cdot 0.000332)$ , that is, to  $t = 12.6/4 = 3.1$  hr, which is  $1/4$  of the original time.
32. According to the physical information given, you have

$$\Delta S = 0.15S \Delta \phi.$$

Now let  $\Delta \phi \rightarrow 0$ . This gives the ODE  $dS/d\phi = 0.15S$ . Separation of variables yields the general solution  $S = S_0 e^{0.15\phi}$  with the arbitrary constant denoted by  $S_0$ . The angle  $\phi$  should be so large that  $S$  equals 1000 times  $S_0$ . Hence  $e^{0.15\phi} = 1000$ ,  $\phi = (\ln 1000)/0.15 = 46 = 7.3 \cdot 2\pi$ , that is, eight times, which is surprisingly little. Equally remarkable is that here we see another application of the ODE  $y' = ky$  and a derivation of it by a *general principle*, namely, by working with small quantities and then taking limits to zero.

36.  $B$  now depends on  $h$ , namely, by the Pythagorean theorem,

$$B(h) = \pi r^2 = \pi(R^2 - (R - h)^2) = \pi(2Rh - h^2).$$

Hence you can use the ODE

$$h' = -26.56(A/B)\sqrt{h}$$

in the text, with constant  $A$  as before and the new  $B$ . The latter makes the further calculations different from those in Example 5.

From the given outlet size  $A = 5 \text{ cm}^2$  and  $B(h)$  we obtain

$$\frac{dh}{dt} = -26.56 \cdot \frac{5}{\pi(2Rh - h^2)} \sqrt{h}.$$

Now  $26.56 \cdot 5/\pi = 42.27$ , so that separation of variables gives

$$(2Rh^{1/2} - h^{3/2}) dh = -42.27 dt.$$

By integration,

$$\frac{4}{3}Rh^{3/2} - \frac{2}{5}h^{5/2} = -42.27t + c.$$

From this and the initial condition  $h(0) = R$  we obtain

$$\frac{4}{3}R^{5/2} - \frac{2}{5}R^{5/2} = 0.9333R^{5/2} = c.$$

Hence the particular solution (in implicit form) is

$$\frac{4}{3}Rh^{3/2} - \frac{2}{5}h^{5/2} = -42.27t + 0.9333R^{5/2}.$$

The tank is empty ( $h = 0$ ) for  $t$  such that

$$0 = -42.27t + 0.9333R^{5/2}; \quad \text{hence} \quad t = \frac{0.9333}{42.27} R^{5/2} = 0.0221R^{5/2}.$$

For  $R = 1 \text{ m} = 100 \text{ cm}$  this gives

$$t = 0.0221 \cdot 100^{5/2} = 2210 \text{ [sec]} = 37 \text{ [min]}.$$

The tank has water level  $R/2$  for  $t$  in the particular solution such that

$$\frac{4}{3}R \frac{R^{3/2}}{2^{3/2}} - \frac{2}{5} \frac{R^{5/2}}{2^{5/2}} = 0.9333R^{5/2} - 42.27t.$$

The left side equals  $0.4007R^{5/2}$ . This gives

$$t = \frac{0.4007 - 0.9333}{-42.27} R^{5/2} = 0.01260R^{5/2}.$$

For  $R = 100$  this yields  $t = 1260 \text{ sec} = 21 \text{ min}$ . This is slightly more than half the time needed to empty the tank. This seems physically reasonable because if the water level is  $R/2$ , this means that  $11/16$  of the total water volume has flown out, and  $5/16$  is left—take into account that the velocity decreases monotone according to Torricelli's law.

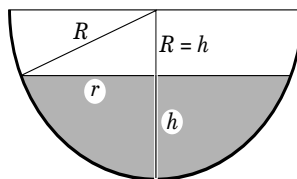

**Problem Set 1.3.** Tank in Problem 36

**SECTION 1.4. Exact ODEs. Integrating Factors, page 19**

**Purpose.** This is the second “big” method in this chapter, after separation of variables, and also applies to equations that are not separable. The criterion (5) is basic. Simpler cases are solved by inspection, more involved cases by integration, as explained in the text.

**Comment on Condition (5)**

Condition (5) is equivalent to (6'') in Sec. 10.2, which is equivalent to (6) in the case of two variables  $x, y$ . Simple connectedness of  $D$  follows from our assumptions in Sec. 1.4. Hence the differential form is exact by Theorem 3, Sec. 10.2, part (b) and part (a), in that order.

**Method of Integrating Factors**

This greatly increases the usefulness of solving exact equations. It is important in itself as well as in connection with linear ODEs in the next section. Problem Set 1.4 will help the student gain skill needed in finding integrating factors. Although the method has somewhat the flavor of tricks, Theorems 1 and 2 show that at least in some cases one can proceed systematically—and one of them is precisely the case needed in the next section for *linear* ODEs.

**SOLUTIONS TO PROBLEM SET 1.4, page 25**

2.  $(x - y) dx + (y - x) dy = 0$ . Exact; the test gives  $-1$  on both sides. Integrate  $x - y$  over  $x$ :

$$u = \frac{1}{2}x^2 - xy + k(y).$$

Differentiate this with respect to  $y$  and compare with  $N$ :

$$u_y = -x + k' = y - x. \quad \text{Thus} \quad k' = y, \quad k = \frac{1}{2}y^2 + c^*.$$

Answer:  $\frac{1}{2}x^2 - xy + \frac{1}{2}y^2 = \frac{1}{2}(x - y)^2 = c$ ; thus  $y = x + \tilde{c}$ .

4. Exact; the test gives  $e^y - e^x$  on both sides. Integrate  $M$  with respect to  $x$  to get

$$u = xe^y - ye^x + k(y).$$

Differentiate this with respect to  $y$  and equate the result to  $N$ :

$$u_y = xe^y - e^x + k' = N = xe^y - e^x.$$

Hence  $k' = 0$ ,  $k = \text{const}$ . Answer:  $xe^y - ye^x = c$ .

6. Exact; the test gives  $-e^x \sin y$  on both sides. Integrate  $M$  with respect to  $x$ :

$$u = e^x \cos y + k(y). \quad \text{Differentiate:} \quad u_y = -e^x \sin y + k'.$$

Equate this to  $N = -e^x \sin y$ . Hence  $k' = 0$ ,  $k = \text{const}$ . Answer:  $e^x \cos y = c$ .

8. Exact;  $-1/x^2 - 1/y^2$  on both sides of the equation. Integrate  $M$  with respect to  $x$ :

$$u = x^2 + \frac{x}{y} + \frac{y}{x} + k(y).$$

Differentiate this with respect to  $y$  and equate the result to  $N$ :

$$u_y = -\frac{x}{y^2} + \frac{1}{x} + k' = N, \quad k' = 2y, \quad k = y^2.$$

Answer:

$$x^2 + \frac{x}{y} + \frac{y}{x} + y^2 = c.$$

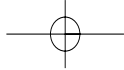

10. Exact; the test gives  $-2x \sin(x^2)$  on both sides. Integrate  $N$  with respect to  $y$  to get

$$u = y \cos(x^2) + l(x).$$

Differentiate this with respect to  $x$  and equate the result to  $M$ :

$$u_x = -2xy \sin(x^2) + l' = M = -2xy \sin(x^2), \quad l' = 0.$$

Answer:  $y \cos(x^2) = c$ .

12. Not exact. Try Theorem 1. In  $R$  you have

$$P_y - Q_x = e^{x+y} - 1 - e^{x+y}(x+1) = -xe^{x+y} - 1 = -Q$$

so that  $R = -1$ ,  $F = e^{-x}$ , and the exact ODE is

$$(e^y - ye^{-x}) dx + (xe^y + e^{-x}) dy = 0.$$

The test gives  $e^y - e^{-x}$  on both sides of the equation. Integration of  $M = FP$  with respect to  $x$  gives

$$u = xe^y + ye^{-x} + k(y).$$

Differentiate this with respect to  $y$  and equate it to  $N = FQ$ :

$$u_y = xe^y + e^{-x} + k' = N = xe^y + e^{-x}.$$

Hence  $k' = 0$ . Answer:  $xe^y + ye^{-x} = c$ .

14. Not exact;  $2y \neq -y$ . Try Theorem 1; namely,

$$R = (P_y - Q_x)/Q = (2y + y)/(-xy) = -3/x. \quad \text{Hence} \quad F = 1/x^3.$$

The exact ODE is

$$\left(x + \frac{y^2}{x^3}\right) dx - \frac{y}{x^2} dy = 0.$$

The test gives  $2y/x^3$  on both sides of the equation. Obtain  $u$  by integrating  $N = FQ$  with respect to  $y$ :

$$u = -\frac{y^2}{2x^2} + l(x). \quad \text{Thus} \quad u_x = \frac{y^2}{x^3} + l' = M = x + \frac{y^2}{x^3}.$$

Hence  $l' = x$ ,  $l = x^2/2$ ,  $-y^2/2x^2 + x^2/2 = c^*$ . Multiply by 2 and use the initial condition  $y(2) = 1$ :

$$x^2 - \frac{y^2}{x^2} = c = 3.75$$

because inserting  $y(2) = 1$  into the last equation gives  $4 - 0.25 = 3.75$ .

16. The given ODE is exact and can be written as  $d(\cos xy) = 0$ ; hence  $\cos xy = c$ , or you can solve it for  $y$  by the usual procedure.  $y(1) = \pi$  gives  $-1 = c$ . Answer:  $\cos xy = -1$ .

18. Try Theorem 2. You have

$$R^* = (Q_x - P_y)/P = \left[ \frac{1}{y} \cos xy - x \sin xy - \left( -x \sin xy - \frac{x}{y^2} \right) \right] / P = \frac{1}{y}.$$

Hence  $F^* = y$ . This gives the exact ODE

$$(y \cos xy + x) dx + (y + x \cos xy) dy = 0.$$



In the test, both sides of the equation are  $\cos xy - xy \sin xy$ . Integrate  $M$  with respect to  $x$ :

$$u = \sin xy + \frac{1}{2}x^2 + k(y). \quad \text{Hence} \quad u_y = x \cos xy + k'(y).$$

Equate the last equation to  $N = y + x \cos xy$ . This shows that  $k' = y$ ; hence  $k = y^2/2$ . *Answer:*  $\sin xy + \frac{1}{2}x^2 + \frac{1}{2}y^2 = c$ .

20. Not exact; try Theorem 2:

$$\begin{aligned} R^* &= (Q_x - P_y)/P = [1 - (\cos^2 y - \sin^2 y - 2x \cos y \sin y)]/P \\ &= [2 \sin^2 y + 2x \cos y \sin y]/P \\ &= 2(\sin y)(\sin y + x \cos y)/(\sin y \cos y + x \cos^2 y) \\ &= 2(\sin y)/\cos y = 2 \tan y. \end{aligned}$$

Integration with respect to  $y$  gives  $-2 \ln(\cos y) = \ln(1/\cos^2 y)$ ; hence  $F^* = 1/\cos^2 y$ . The resulting exact equation is

$$(\tan y + x) dx + \frac{x}{\cos^2 y} dy = 0.$$

The exactness test gives  $1/\cos^2 y$  on both sides. Integration of  $M$  with respect to  $x$  yields

$$u = x \tan y + \frac{1}{2}x^2 + k(y). \quad \text{From this,} \quad u_y = \frac{x}{\cos^2 y} + k'.$$

Equate this to  $N = x/\cos^2 y$  to see that  $k' = 0$ ,  $k = \text{const}$ . *Answer:*  $x \tan y + \frac{1}{2}x^2 = c$ .

22. (a) Not exact. Theorem 2 applies and gives  $F^* = 1/y$  from

$$R^* = (Q_x - P_y)/P = (0 - \cos x)/(y \cos x) = -\frac{1}{y}.$$

Integrating  $M$  in the resulting exact ODE

$$\cos x dx + \frac{1}{y^2} dy = 0$$

with respect to  $x$  gives

$$u = \sin x + k(y). \quad \text{From this,} \quad u_y = k' = N = \frac{1}{y^2}.$$

Hence  $k = -1/y$ . *Answer:*  $\sin x - 1/y = c$ .

Note that the integrating factor  $1/y$  could have been found by inspection and by the fact that an ODE of the general form

$$f(x) dx + g(y) dy = 0$$

is always exact, the test resulting in 0 on both sides.

(b) Yes. Separation of variables gives

$$dy/y^2 = -\cos x dx. \quad \text{By integration,} \quad -1/y = -\sin x + c^*$$

in agreement with the solution in (a).

(d) seems better than (c). But this may depend on your CAS. In (d) the CAS may draw vertical asymptotes that disturb the figure.

From the solution in (a) or (b) the student should conclude that for each nonzero  $y(x_0) = y_0$  there is a unique particular solution because

$$\sin x_0 - 1/y_0 = c.$$

24. (A)  $e^y \cosh x = c$ .

(B)  $R^* = \tan y$ ,  $F = 1/\cos y$ . Separation:

$$dy/\cos^2 y = -(1 + 2x) dx, \quad \tan y = -x - x^2 + c.$$

(C)  $R = -2/x$ ,  $F = 1/x^2$ ,  $x - y^2/x = c$ .  $v = y/x$ , and separation:

$$2v dv/(1 - v^2) = dx/x, \quad x^2 - y^2 = cx;$$

divide by  $x$ .

(D) Separation is simplest.  $y = cx^{-3/4}$ .  $R = -9/(4x)$ ,  $F(x) = x^{-9/4}$ ,  $x^3 y^4 = c$ .  
 $R^* = 3/y$ ,  $F^*(y) = y^3$ .

### SECTION 1.5. Linear ODEs. Bernoulli Equation. Population Dynamics, page 26

**Purpose.** Linear ODEs are of great practical importance, as Problem Set 1.5 illustrates (and even more so are second-order linear ODEs in Chap. 2). We show that the homogeneous ODE of the first order is easily separated and the nonhomogeneous ODE is solved, once and for all, in the form of an integral (4) by the method of integrating factors. Of course, in simpler cases one does not need (4), as our examples illustrate.

#### Comment on Notation

We write

$$y' + p(x)y = r(x).$$

$p(x)$  seems standard.  $r(x)$  suggests “right side.” The notation

$$y' + p(x)y = q(x)$$

used in some calculus books (which are not concerned with higher order ODEs) would be shortsighted here because later, in Chap. 2, we turn to second-order ODEs

$$y'' + p(x)y' + q(x)y = r(x),$$

where we need  $q(x)$  on the left, thus in a quite different role (and on the right we would have to choose another letter different from that used in the first-order case).

#### Comment on Content

**Bernoulli's equation** appears occasionally in practice, so the student should remember how to handle it.

A special Bernoulli equation, the **Verhulst equation**, plays a central role in population dynamics of humans, animals, plants, and so on, and we give a short introduction to this interesting field, along with one reference in the text.

**Riccati** and **Clairaut equations** are less important than Bernoulli's, so we have put them in the problem set; they will not be needed in our further work.

**Input** and **output** have become common terms in various contexts, so we thought this a good place to mention them.

Problems 37–42 express properties that make linearity important, notably in obtaining new solutions from given ones. The counterparts of these properties will, of course, reappear in Chap. 2.

#### Comment on Footnote 5

Eight members of the Bernoulli family became known as mathematicians; for more details, see p. 220 in Ref. [GR2] listed in App. 1.

**SOLUTIONS TO PROBLEM SET 1.5, page 32**

4. The standard form (1) is  $y' - 4y = x$ , so that (4) gives

$$y = e^{4x} \left[ \int e^{-4x} x \, dx + c \right] = ce^{4x} - x/4 - 1/16.$$

6. The standard form (1) is  $y' + \frac{3}{x}y = \frac{1}{x^3}$ . From this and (4) we obtain, with  $c = -2$  from the initial condition,

$$y = x^{-3} \left[ \int x^3 x^{-3} \, dx + c \right] = x^{-3}[x + c] = x^{-2} - 2x^{-3}.$$

8. From (4) with  $p = 2$ ,  $h = 2x$ ,  $r = 4 \cos 2x$  we obtain

$$y = e^{-2x} \left[ \int e^{2x} 4 \cos 2x \, dx + c \right] = e^{-2x}[e^{2x}(\cos 2x + \sin 2x) + c].$$

It is perhaps worthwhile mentioning that integrals of this type can more easily be evaluated by undetermined coefficients. Also, the student should verify the result by differentiation, even if it was obtained by a CAS. From the initial condition we obtain

$$y(\frac{1}{4}\pi) = ce^{-\pi/2} + 0 + 1 = 2; \quad \text{hence} \quad c = e^{\pi/2}.$$

The *answer* can be written

$$y = e^{\pi/2 - 2x} + \cos 2x + \sin 2x.$$

10. In (4) we have  $p = 4x^2$ ; hence  $h = 4x^3/3$ , so that (4) gives

$$y = e^{-4x^3/3} \left[ \int e^{(4x^3/3) - x^2/2} (4x^2 - x) \, dx + c \right].$$

The integral can be evaluated by noting that the factor of the exponential function under the integral sign is the derivative of the exponent of that function. We thus obtain

$$y = e^{-4x^3/3} [e^{(4x^3/3) - x^2/2} + c] = ce^{-4x^3/3} + e^{-x^2/2}.$$

12.  $y' \tan x = 2(y - 4)$ . Separation of variables gives

$$\frac{dy}{y - 4} = 2 \frac{\cos x}{\sin x} \, dx. \quad \text{By integration,} \quad \ln |y - 4| = 2 \ln |\sin x| + c^*.$$

Taking exponents on both sides gives

$$y - 4 = c \sin^2 x, \quad y = c \sin^2 x + 4.$$

The desired particular solution is obtained from the initial condition

$$y(\frac{1}{2}\pi) = c + 4 = 0, \quad c = -4. \quad \text{Answer: } y = 4 - 4 \sin^2 x.$$

14. In (4) we have  $p = \tan x$ ,  $h = -\ln(\cos x)$ ,  $e^h = 1/\cos x$ , so that (4) gives

$$y = (\cos x) \left[ \int \frac{\cos x}{\cos x} e^{-0.01x} \, dx + c \right] = [-100 e^{-0.01x} + c] \cos x.$$

The initial condition gives  $y(0) = -100 + c = 0$ ; hence  $c = 100$ . The particular solution is

$$y = 100(1 - e^{-0.01x}) \cos x.$$

The factor 0.01, which we included in the exponent, has the effect that the graph of  $y$  shows a long transition period. Indeed, it takes  $x = 460$  to let the exponential function  $e^{-0.01x}$  decrease to 0.01. Choose the  $x$ -interval of the graph accordingly.

16. The standard form (1) is

$$y' + \frac{3}{\cos^2 x} y = \frac{1}{\cos^2 x}.$$

Hence  $h = 3 \tan x$ , and (4) gives the general solution

$$y = e^{-3 \tan x} \left[ \int \frac{e^{3 \tan x}}{\cos^2 x} dx + c \right].$$

To evaluate the integral, observe that the integrand is of the form

$$\frac{1}{3}(3 \tan x)' e^{3 \tan x},$$

that is,

$$\frac{1}{3}(e^{3 \tan x})'.$$

Hence the integral has the value  $\frac{1}{3}e^{3 \tan x}$ . This gives the general solution

$$y = e^{-3 \tan x} \left[ \frac{1}{3}e^{3 \tan x} + c \right] = \frac{1}{3} + ce^{-3 \tan x}.$$

The initial condition gives from this

$$y\left(\frac{1}{4}\pi\right) = \frac{1}{3} + ce^{-3} = \frac{4}{3}; \quad \text{hence} \quad c = e^3.$$

The answer is  $y = \frac{1}{3} + e^{3-3 \tan x}$ .

18. Bernoulli equation. *First solution method:* Transformation to linear form. Set  $y = 1/u$ . Then  $y' + y = -u'/u^2 + 1/u = 1/u^2$ . Multiplication by  $-u^2$  gives the linear ODE in standard form

$$u' - u = -1. \quad \text{General solution} \quad u = ce^x + 1.$$

Hence the given ODE has the general solution

$$y = 1/(ce^x + 1).$$

From this and the initial condition  $y(0) = -1$  we obtain

$$y(0) = 1/(c + 1) = -1, \quad c = -2, \quad \text{Answer:} \quad y = 1/(1 - 2e^x).$$

*Second solution method:* Separation of variables and use of partial fractions.

$$\frac{dy}{y(y-1)} = \left( \frac{1}{y-1} - \frac{1}{y} \right) dy = dx.$$

Integration gives

$$\ln |y-1| - \ln |y| = \ln \left| \frac{y-1}{y} \right| = x + c^*.$$

Taking exponents on both sides, we obtain

$$\frac{y-1}{y} = 1 - \frac{1}{y} = \tilde{c}e^x, \quad \frac{1}{y} = 1 - \tilde{c}e^x, \quad y = \frac{1}{1 + ce^x}.$$

We now continue as before.



20. Separate variables, integrate, and take exponents:

$$\cot y \, dy = -dx/(x^2 + 1), \quad \ln |\sin y| = -\arctan x + c^*$$

and

$$\sin y = ce^{-\arctan x}.$$

Now use the initial condition  $y(0) = \frac{1}{2}\pi$ :

$$1 = ce^0, \quad c = 1.$$

Answer:  $y = \arcsin(e^{-\arctan x})$ .

22. *First solution method:* by setting  $z = \cos 2y$  (*linearization*): From  $z$  we have

$$z' = (-2 \sin 2y)y'. \quad \text{From the ODE,} \quad -\frac{1}{2}z' + xz = 2x.$$

This is a linear ODE. Its standard form is

$$z' - 2xz = -4x. \quad \text{In (4) this gives} \quad p = -2x, \quad h = -x^2.$$

Hence (4) gives the solution in terms of  $z$  in the form

$$z = e^{x^2} \left[ \int e^{-x^2}(-4x) \, dx + c \right] = e^{x^2}[2e^{-x^2} + c] = 2 + ce^{x^2}.$$

From this we obtain the solution

$$y = \frac{1}{2} \arccos z = \frac{1}{2} \arccos(2 + ce^{x^2}).$$

*Second solution method: Separation of variables.* By algebra,

$$y' \sin 2y = x(-\cos 2y + 2).$$

Separation of variables now gives

$$\frac{\sin 2y}{2 - \cos 2y} \, dy = x \, dx. \quad \text{Integrate:} \quad \frac{1}{2} \ln |2 - \cos 2y| = \frac{1}{2}x^2 + c^*.$$

Multiply by 2 and take exponents:

$$\ln |2 - \cos 2y| = x^2 + 2c^*, \quad 2 - \cos 2y = \tilde{c}e^{x^2}.$$

Solve this for  $y$ :

$$\cos 2y = 2 - \tilde{c}e^{x^2}, \quad y = \frac{1}{2} \arccos(2 - \tilde{c}e^{x^2}).$$

24. Bernoulli ODE. Set  $u = y^3$  and note that  $u' = 3y^2y'$ . Multiply the given ODE by  $3y^2$  to obtain

$$3y^2y' + 3x^2y^3 = e^{-x^3} \sinh x.$$

In terms of  $u$  this gives the linear ODE

$$u' + 3x^2u = e^{-x^3} \sinh x.$$

In (4) we thus have  $h = x^3$ . The solution is

$$u = e^{-x^3} \left[ \int e^{x^3} e^{-x^3} \sinh x \, dx + c \right] = e^{-x^3} [\cosh x + c]$$

and  $y = u^{1/3}$ .

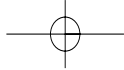

26. The salt content in the inflow is  $50(1 + \cos t)$ . Let  $y(t)$  be the salt content in the tank to be determined. Then  $y(t)/1000$  is the salt content per gallon. Hence  $(50/1000)y(t)$  is the salt content in the outflow per minute. The rate of change  $y'$  equals the balance,

$$y' = \text{In} - \text{Out} = 50(1 + \cos t) - 0.05y.$$

Thus  $y' + 0.05y = 50(1 + \cos t)$ . Hence  $p = 0.05$ ,  $h = 0.05t$ , and (4) gives the general solution

$$\begin{aligned} y &= e^{-0.05t} \left( \int e^{0.05t} 50(1 + \cos t) dt + c \right) \\ &= e^{-0.05t} (e^{0.05t} (1000 + a \cos t + b \sin t) + c) \\ &= 1000 + a \cos t + b \sin t + ce^{-0.05t} \end{aligned}$$

where  $a = 2.5/(1 + 0.05^2) = 2.494$  and  $b = 50/(1 + 0.05^2) = 49.88$ , which we obtained by evaluating the integral. From this and the initial condition  $y(0) = 200$  we have

$$y(0) = 1000 + a + c = 200, \quad c = 200 - 1000 - a = -802.5.$$

Hence the solution of our problem is

$$y(t) = 1000 + 2.494 \cos t + 49.88 \sin t - 802.5e^{-0.05t}.$$

Figure 20 shows the solution  $y(t)$ . The last term in  $y(t)$  is the only term that depends on the initial condition (because  $c$  does). It decreases monotone. As a consequence,  $y(t)$  increases but keeps oscillating about 1000 as the limit of the mean value.

This mean value is also shown in Fig. 20. It is obtained as the solution of the ODE

$$y' + 0.05y = 50.$$

Its solution satisfying the initial condition is

$$y = 1000 - 800e^{-0.05t}.$$

28.  $k_1(T - T_a)$  follows from Newton's law of cooling.  $k_2(T - T_w)$  models the effect of heating or cooling.  $T > T_w$  calls for cooling; hence  $k_2(T - T_w)$  should be negative in this case; this is true, since  $k_2$  is assumed to be negative in this formula. Similarly for heating, when heat should be added, so that the temperature increases.

The given model is of the form

$$T' = kT + K + k_1C \cos(\pi/12)t.$$

This can be seen by collecting terms and introducing suitable constants,  $k = k_1 + k_2$  (because there are two terms involving  $T$ ), and  $K = -k_1A - k_2T_w + P$ . The general solution is

$$T = ce^{kt} - K/k + L(-k \cos(\pi t/12) + (\pi/12) \sin(\pi t/12)),$$

where  $L = k_1C/(k^2 + \pi^2/144)$ . The first term solves the homogeneous ODE  $T' = kT$  and decreases to zero. The second term results from the constants  $A$  (in  $T_a$ ),  $T_w$ , and  $P$ . The third term is sinusoidal, of period 24 hours, and time-delayed against the outside temperature, as is physically understandable.

30.  $y' = ky(1 - y) = f(y)$ , where  $k > 0$  and  $y$  is the proportion of infected persons. Equilibrium solutions are  $y = 0$  and  $y = 1$ . The first,  $y = 0$ , is unstable because

$f(y) > 0$  if  $0 < y < 1$  but  $f(y) < 0$  for negative  $y$ . The solution  $y = 1$  is stable because  $f(y) > 0$  if  $0 < y < 1$  and  $f(y) < 0$  if  $y > 1$ . The general solution is

$$y = \frac{1}{1 + ce^{-kt}}.$$

It approaches 1 as  $t \rightarrow \infty$ . This means that eventually everybody in the population will be infected.

32. The model is

$$y' = Ay - By^2 - Hy = Ky - By^2 = y(K - By)$$

where  $K = A - H$ . Hence the general solution is given by (9) in Example 4 with  $A$  replaced by  $K = A - H$ . The equilibrium solutions are obtained from  $y' = 0$ ; hence they are  $y_1 = 0$  and  $y_2 = K/B$ . The population  $y_2$  remains unchanged under harvesting, and the fraction  $Hy_2$  of it can be harvested indefinitely—hence the name.

34. For the first 3 years you have the solution

$$y_1 = 4/(5 - 3e^{-0.8t})$$

from Prob. 32. The idea now is that, by continuity, the value  $y_1(3)$  at the end of the first period is the initial value for the solution  $y_2$  during the next period. That is,

$$y_2(3) = y_1(3) = 4/(5 - 3e^{-2.4}).$$

Now  $y_2$  is the solution of  $y' = y - y^2$  (no fishing!). Because of the initial condition this gives

$$y_2 = 4/(4 + e^{3-t} - 3e^{0.6-t}).$$

Check the continuity at  $t = 3$  by calculating

$$y_2(3) = 4/(4 + e^0 - 3e^{-2.4}).$$

Similarly, for  $t$  from 6 to 9 you obtain

$$y_3 = 4/(5 - e^{4.8-0.8t} + e^{1.8-0.8t} - 3e^{-0.6-0.8t}).$$

This is a period of fishing. Check the continuity at  $t = 6$ :

$$y_3(6) = 4/(5 - e^0 + e^{-3} - 3e^{-5.4}).$$

This agrees with

$$y_2(6) = 4/(4 + e^{-3} - 3e^{-5.4}).$$

36.  $y_1 = 1/u_1$ ,

$$u_1(0) = 1/y_1(0) = 0.5,$$

$$y_1' = -u_1'/u_1^2 = 0.8y_1 - y_1^2 = 0.8/u_1 - 1/u_1^2,$$

$$u_1' + 0.8u_1 = 1,$$

$$u_1 = 1.25 + c_1e^{-0.8t}$$

$$= 1.25 - 0.75e^{-0.8t} = 1/y_1$$

for  $0 < t < 3$ .  $u_2' + u_2 = 1$ ,  $u_2 = 1 + c_2e^{-t}$ . The continuity condition is

$$u_2(3) = 1 + c_2e^{-3} = u_1(3) = 1.25 - 0.75e^{-2.4}.$$

For  $c_2$  this gives

$$c_2 = e^3(-1 + 1.25 - 0.75e^{-2.4}) = 0.25e^3 - 0.75e^{0.6}.$$

This gives for  $3 < t < 6$

$$u_2 = 1 + 0.25e^{3-t} - 0.75e^{0.6-t} = 1/y_2.$$

Finally, for  $6 < t < 9$  we have the ODE is  $u_3' + 0.8u_3 = 1$ , whose general solution is

$$u_3 = 1.25 + c_3e^{-0.8t}.$$

$c_3$  is determined by the continuity condition at  $t = 6$ , namely,

$$u_3(6) = 1.25 + c_3e^{-4.8} = u_2(6) = 1 + 0.25e^{-3} - 0.75e^{-5.4}.$$

This gives

$$\begin{aligned} c_3 &= e^{4.8}(-1.25 + 1 + 0.25e^{-3} - 0.75e^{-5.4}) \\ &= -0.25e^{4.8} + 0.25e^{1.8} - 0.75e^{-0.6}. \end{aligned}$$

Substitution gives the solution for  $6 < t < 9$ :

$$u_3 = 1.25 + (-0.25e^{4.8} + 0.25e^{1.8} - 0.75e^{-0.6})e^{-0.8t} = 1/y_3.$$

38. Substitution gives the identity  $0 = 0$ .

These problems are of importance because they show why linear ODEs are preferable over nonlinear ones in the modeling process. Thus one favors a linear ODE over a nonlinear one if the model is a faithful mathematical representation of the problem. Furthermore, these problems illustrate the difference between homogeneous and nonhomogeneous ODEs.

40. We obtain

$$\begin{aligned} (y_1 - y_2)' + p(y_1 - y_2) &= y_1' - y_2' + py_1 - py_2 \\ &= (y_1' + py_1) - (y_2' + py_2) \\ &= r - r \\ &= 0. \end{aligned}$$

42. The sum satisfies the ODE with  $r_1 + r_2$  on the right. This is important as the key to the method of developing the right side into a series, then finding the solutions corresponding to single terms, and finally, adding these solutions to get a solution of the given ODE. For instance, this method is used in connection with Fourier series, as we shall see in Sec. 11.5.

44. (a)  $y = Y + v$  reduces the Riccati equation to a Bernoulli equation by removing the term  $h(x)$ . The second transformation,  $v = 1/u$ , is the usual one for transforming a Bernoulli equation with  $y^2$  on the right into a linear ODE.

Substitute  $y = Y + 1/u$  into the Riccati equation to get

$$Y' - u'/u^2 + p(Y + 1/u) = g(Y^2 + 2Y/u + 1/u^2) + h.$$

Since  $Y$  is a solution,  $Y' + pY = gY^2 + h$ . There remains

$$-u'/u^2 + p/u = g(2Y/u + 1/u^2).$$

Multiplication by  $-u^2$  gives  $u' - pu = -g(2Yu + 1)$ . Reshuffle terms to get

$$u' + (2Yg - p)u = -g,$$

the linear ODE as claimed.

(b) Substitute  $y = Y = x$  to get  $1 - 2x^4 - x = -x^4 - x^4 - x + 1$ , which is true. Now substitute  $y = x + 1/u$ . This gives

$$1 - u'/u^2 - (2x^3 + 1)(x + 1/u) = -x^2(x^2 + 2x/u + 1/u^2) - x^4 - x + 1.$$

Most of the terms cancel on both sides. There remains  $-u'/u^2 - 1/u = -x^2/u^2$ . Multiplication by  $-u^2$  finally gives  $u' + u = x^2$ . The general solution is

$$u = ce^{-x} + x^2 - 2x + 2$$

and  $y = x + 1/u$ . Of course, instead performing this calculation we could have used the general formula in (a), in which

$$2Yg - p = 2x(-x^2) + 2x^3 + 1 = 1 \quad \text{and} \quad -g = +x^2.$$

(c) Substitution of  $Y = x^2$  shows that this is a solution. In the ODE for  $u$  you find

$$2Yg - p = 2x^2(-\sin x) - (3 - 2x^2 \sin x) = -3.$$

Also,  $g = -\sin x$ . Hence the ODE for  $u$  is  $u' - 3u = \sin x$ . Solution:

$$u = ce^{3x} - 0.1 \cos x - 0.3 \sin x \quad \text{and} \quad y = x^2 + 1/u.$$

(e)  $y' = y' + xy'' - y''/y'^2$  by the chain rule. Hence  $y''(x - 1/y'^2) = 0$ .

(A) From  $y'' = 0$  we obtain by integrations  $y = cx + a$ . Substitution into the given ODE gives  $cx + a = xc + 1/c$ ; hence  $a = 1/c$ . This is a family of straight lines.

(B) The other factor is zero when  $x = 1/y'^2$ . By integration,  $y = 2x^{1/2} + c^*$ . Substituting  $y$  and  $y' = x^{-1/2}$  into the given equation  $y = xy' + 1/y'$ , we obtain

$$2x^{1/2} + c^* = x \cdot x^{-1/2} + 1/x^{-1/2},$$

hence  $c^* = 0$ . This gives the singular solution  $y = 2\sqrt{x}$ , a curve, to which those straight lines in (A) are tangent.

(f) By differentiation,  $2y'y'' - y' - xy'' + y' = 0$ ,  $y''(2y' - x) = 0$ , (A)  $y'' = 0$ ,  $y = cx + a$ . By substitution,  $c^2 - xc + cx + a = 0$ ,  $a = -c^2$ ,  $y = cx - c^2$ , a family of straight lines. (B)  $y' = x/2$ ,  $y = x^2/4 + c^*$ . By substitution into the given ODE,  $x^2/4 - x^2/2 + x^2/4 + c^* = 0$ ,  $c^* = 0$ ,  $y = x^2/4$ , the envelope of the family; see Fig. 6 in Sec. 1.1.

### SECTION 1.6. Orthogonal Trajectories. *Optional*, page 35

**Purpose.** To show that families of curves  $F(x, y, c) = 0$  can be described by ODEs  $y' = f(x, y)$  and the switch to  $\tilde{y}' = -1/f(x, \tilde{y})$  produces as general solution the orthogonal trajectories. This is a nice application that may also help the student to gain more self-confidence, skill, and a deeper understanding of the nature of ODEs.

We leave this section *optional*, for reasons of time. This will cause no gap.

The reason why ODEs can be applied in this fashion results from the fact that general solutions of ODEs involve an arbitrary constant that serves as the parameter of this one-parameter family of curves determined by the given ODE, and then another general solution similarly determines the one-parameter family of the orthogonal trajectories.

Curves and their orthogonal trajectories play a role in several physical applications (e.g., in connection with electrostatic fields, fluid flows, and so on).

**SOLUTIONS TO PROBLEM SET 1.6, page 36**

2.  $xy = c$ , and by differentiation,  $y + xy' = 0$ ; hence  $y' = -y/x$ . The ODE of the trajectories is  $\tilde{y}' = x/\tilde{y}$ . By separation and integration,  $\tilde{y}^2/2 = x^2/2 + c^*$ . Hyperbolas. (So are the given curves.)

4. By differentiation,  $2yy' = 4x$ ; hence  $y' = 2x/y$ . Thus the ODE of the trajectories is  $\tilde{y}' = -\tilde{y}/2x$ . By separating, integrating, and taking exponents on both sides,

$$d\tilde{y}/\tilde{y} = -dx/2x, \quad \ln |\tilde{y}| = -\frac{1}{2} \ln |x| + c^{**}, \quad \tilde{y} = c^*/\sqrt{x}.$$

6.  $ye^{3x} = c$ . Differentiation gives

$$(y' + 3y)e^{3x} = 0.$$

Hence the ODE of the given family is  $y' = -3y$ . For the trajectories we obtain

$$\tilde{y}' = 1/(3\tilde{y}), \quad \tilde{y}\tilde{y}' = \frac{1}{3}, \quad \frac{1}{2}\tilde{y}^2 = \frac{1}{3}x + c^{**}, \quad \tilde{y} = \sqrt{\frac{2}{3}x + c^*}.$$

8.  $2x - 2yy' = 0$ , so that the ODE of the curves is  $y' = x/y$ .

Hence the ODE of the trajectories is  $\tilde{y}' = -\tilde{y}/x$ . Separating variables, integrating, and taking exponents gives hyperbolas as trajectories; namely,

$$\tilde{y}'/\tilde{y} = -1/x, \quad \ln |\tilde{y}| = -\ln |x| + c^{**}, \quad x\tilde{y} = c^*.$$

10.  $xy^{-1/2} = \hat{c}$ , or  $x^2y^{-1} = c$ . By differentiation,

$$2xy^{-1} - x^2y^{-2}y' = 0, \quad y' = 2y/x.$$

This is the ODE of the given family. Hence the orthogonal trajectories have the ODE

$$\tilde{y}' = -\frac{x}{2\tilde{y}}. \quad \text{Thus} \quad 2\tilde{y}\tilde{y}' = -x, \quad \tilde{y}^2 = -\frac{1}{2}x^2 + c^* \quad (\text{ellipses}).$$

12.  $x^2 + y^2 - 2cy = 0$ . Solve algebraically for  $2c$ :

$$\frac{x^2 + y^2}{y} = \frac{x^2}{y} + y = 2c.$$

Differentiation gives

$$\frac{2x}{y} - \frac{x^2y'}{y^2} + y' = 0.$$

By algebra,

$$y' \left( -\frac{x^2}{y^2} + 1 \right) = -\frac{2x}{y}.$$

Solve for  $y'$ :

$$y' = -\frac{2x}{y} \bigg/ \left( \frac{y^2 - x^2}{y^2} \right) = \frac{-2xy}{y^2 - x^2}.$$

This is the ODE of the given family. Hence the ODE of the trajectories is

$$\tilde{y}' = \frac{\tilde{y}^2 - x^2}{2x\tilde{y}} = \frac{1}{2} \left( \frac{\tilde{y}}{x} - \frac{x}{\tilde{y}} \right).$$

To solve this equation, set  $u = \tilde{y}/x$ . Then

$$\tilde{y}' = xu' + u = \frac{1}{2} \left( u - \frac{1}{u} \right).$$

Subtract  $u$  on both sides to get

$$xu' = -\frac{u^2 + 1}{2u}.$$

Now separate variables, integrate, and take exponents, obtaining

$$\frac{2u \, du}{u^2 + 1} = -\frac{dx}{x}, \quad \ln(u^2 + 1) = -\ln|x| + c_1, \quad u^2 + 1 = \frac{c_2}{x}.$$

Write  $u = \tilde{y}/x$  and multiply by  $x^2$  on both sides of the last equation. This gives

$$\tilde{y}^2 + x^2 = c_2x.$$

The *answer* is

$$(x - c_3)^2 + \tilde{y}^2 = c_3^2.$$

Note that the given circles all have their centers on the  $y$ -axis and pass through the origin. The result shows that their orthogonal trajectories are circles, too, with centers on the  $x$ -axis and passing through the origin.

14. By differentiation,  $g_x \, dx + g_y \, dy = 0$ . Hence  $y' = -g_x/g_y$ . This implies that the trajectories are obtained from

$$\tilde{y}' = g_{\tilde{y}}/g_x.$$

For Prob. 6 we obtain  $ye^{3x} = c$  and by differentiation,

$$\tilde{y}' = \frac{e^{3x}}{3\tilde{y}e^{3x}} = \frac{1}{3\tilde{y}}, \quad \tilde{y}\tilde{y}' = \frac{1}{3}, \quad \frac{\tilde{y}^2}{2} = \frac{x}{3} + c^{**}$$

and so forth.

16. Differentiating  $xy = c$ , we have  $y + xy' = 0$ , so that the ODE of the given hyperbolas is  $y' = -y/x$ . The trajectories are thus obtained by solving  $\tilde{y}' = x/\tilde{y}$ . By separation of variables and integration we obtain

$$\tilde{y}\tilde{y}' = x \quad \text{and} \quad \tilde{y}^2 - x^2 = c^*$$

(hyperbolas).

18. Setting  $y = 0$  gives from  $x^2 + (y - c)^2 = 1 + c^2$  the equation  $x^2 + c^2 = 1 + c^2$ ; hence  $x = -1$  and  $x = 1$ , which verifies that those circles all pass through  $-1$  and  $1$ , each of them simultaneously through both points. Subtracting  $c^2$  on both sides of the given equation, we obtain

$$x^2 + y^2 - 2cy = 1, \quad x^2 + y^2 - 1 = 2cy, \quad \frac{x^2 - 1}{y} + y = 2c.$$

Emphasize to your class that the ODE for the given curves must always be free of  $c$ . Having accomplished this, we can now differentiate. This gives

$$\frac{2x}{y} - \left( \frac{x^2 - 1}{y^2} - 1 \right) y' = 0.$$

This is the ODE of the given curves. Replacing  $y'$  with  $-1/\tilde{y}'$  and  $y$  with  $\tilde{y}$ , we obtain the ODE of the trajectories:

$$\frac{2x}{\tilde{y}} - \left( \frac{x^2 - 1}{\tilde{y}^2} - 1 \right) / (-\tilde{y}') = 0.$$

Multiplying this by  $y'$ , we get

$$\frac{2x\tilde{y}'}{\tilde{y}} + \frac{x^2 - 1}{\tilde{y}^2} - 1 = 0.$$

Multiplying this by  $\tilde{y}^2/x^2$ , we obtain

$$\frac{2\tilde{y}\tilde{y}'}{x} + 1 - \frac{1}{x^2} - \frac{\tilde{y}^2}{x^2} = \frac{d}{dx} \left( \frac{\tilde{y}^2}{x} \right) + 1 - \frac{1}{x^2} = 0.$$

By integration,

$$\frac{\tilde{y}^2}{x} + x + \frac{1}{x} = 2c^*. \quad \text{Thus,} \quad \tilde{y}^2 + x^2 + 1 = 2c^*x.$$

We see that these are the circles

$$\tilde{y}^2 + (x - c^*)^2 = c^{*2} - 1$$

dashed in Fig. 25, as claimed.

**20. (B)** By differentiation,

$$\frac{2x}{a^2} + \frac{2yy'}{b^2} = 0, \quad y' = -\frac{2x/a^2}{2y/b^2} = -\frac{b^2x}{a^2y}.$$

Hence the ODE of the orthogonal trajectories is

$$\tilde{y}' = \frac{a^2\tilde{y}}{b^2x}. \quad \text{By separation,} \quad \frac{d\tilde{y}}{\tilde{y}} = \frac{a^2}{b^2} \frac{dx}{x}.$$

Integration and taking exponents gives

$$\ln|\tilde{y}| = \frac{a^2}{b^2} \ln|x| + c^{**}, \quad \tilde{y} = c^*x^{a^2/b^2}.$$

This shows that the ratio  $a^2/b^2$  has substantial influence on the form of the trajectories. For  $a^2 = b^2$  the given curves are circles, and we obtain straight lines as trajectories.  $a^2/b^2 = 2$  gives quadratic parabolas. For higher integer values of  $a^2/b^2$  we obtain parabolas of higher order. Intuitively, the “flatter” the ellipses are, the more rapidly the trajectories must increase to have orthogonality.

Note that our discussion also covers families of parabolas; simply interchange the roles of the curves and their trajectories.

**(C)** For hyperbolas we have a minus sign in the formula of the given curves. This produces a plus sign in the ODE for the curves and a minus sign in the ODE for the trajectories:

$$y' = -\frac{a^2y}{b^2x}.$$

Separation of variables and integration gives

$$y = c^*x^{-a^2/b^2}.$$

For  $a^2/b^2 = 1$  we obtain the hyperbolas  $y = c^*x$ , and for higher values of  $a^2/b^2$  we obtain less familiar curves.

**(D)** The problem set of this section contains other families of curves whose trajectories can be readily obtained by solving the corresponding ODEs.



**SECTION 1.7. Existence and Uniqueness of Solutions, page 37**

**Purpose.** To give the student at least some impression of the theory that would occupy a central position in a more theoretical course on a higher level.

**Short Courses.** This section can be omitted.

**Comment on Iteration Methods**

Iteration methods were used rather early in history, but it was Picard who made them popular. Proofs of the theorems in this section (given in books of higher level, e.g., [A11]) are based on the Picard iteration (see CAS Project 10).

Iterations are well suited for the computer because of their modest storage demand and usually short programs in which the same loop or loops are used many times, with different data. Because integration is generally not difficult for a CAS, Picard's method has gained some popularity during the past few decades.

**SOLUTIONS TO PROBLEM SET 1.7, page 41**

2. The initial condition is given at the point  $x = 1$ . The coefficient of  $y'$  is 0 at that point, so from the ODE we already see that something is likely to go wrong. Separating variables, integrating, and taking exponents gives

$$\frac{dy}{y} = \frac{2 dx}{x-1}, \quad \ln |y| = 2 \ln |x-1| + c^*, \quad y = c(x-1)^2.$$

This last expression is the general solution. It shows that  $y(1) = 0$  for any  $c$ . Hence the initial condition  $y(1) = 1$  cannot be satisfied. This does not contradict the theorems because we first have to write the ODE in standard form:

$$y' = f(x, y) = \frac{2y}{x-1}.$$

This shows that  $f$  is not defined when  $x = 1$  (to which the initial condition refers).

4. For  $k \neq 0$  we still get no solution, violating the existence as in Prob. 2. For  $k = 0$  we obtain infinitely many solutions, because  $c$  remains unspecified. Thus in this case the uniqueness is violated. Neither of the two theorems is violated in either case.
6. By separation and integration,

$$\frac{dy}{y} = \frac{2x-4}{x^2-4x} dx, \quad \ln |y| = \ln |x^2-4x| + c^*.$$

Taking exponents gives the general solution

$$y = c(x^2 - 4x).$$

From this we can see the *answers*:

No solution if  $y(0) = k \neq 0$  or  $y(4) = k \neq 0$ .

A unique solution if  $y(x_0)$  equals any  $y_0$  and  $x_0 \neq 0$  or  $x_0 \neq 4$ .

Infinitely many solutions if  $y(0) = 0$  or  $y(4) = 0$ .

This does not contradict the theorems because

$$f(x, y) = \frac{2x-4}{x^2-4x}$$

is not defined when  $x = 0$  or  $4$ .

8. (A) The student should gain an understanding for the “intermediate” position of a Lipschitz condition: it is more than continuity but less than partial differentiability.  
 (B) Here the student should realize that the linear ODE is basically simpler than a nonlinear ODE. The calculation is straightforward because

$$f(x, y) = r(x) - p(x)y$$

and implies that

$$|f(x, y_2) - f(x, y_1)| = |p(x)| |y_2 - y_1| \leq M|y_2 - y_1|$$

where the boundedness  $|p(x)| \leq M$  for  $|x - x_0| \leq a$  follows from the continuity of  $p$  in this closed interval.

10. (B)  $y_n = \frac{x^2}{2!} + \frac{x^3}{3!} + \cdots + \frac{x^{n+1}}{(n+1)!}$ ,  $y = e^x - x - 1$

(C)  $y_0 = 1, y_1 = 1 + 2x, y_2 = 1 + 2x + 4x^2 + \frac{8x^3}{3}, \dots$

$$y(x) = \frac{1}{1 - 2x} = 1 + 2x + 4x^2 + 8x^3 + \cdots$$

(D)  $y = (x - 1)^2, y = 0$ . It approximates  $y = 0$ . General solution  $y = (x + c)^2$ .

(E)  $y' = y$  would be a good candidate to begin with. Perhaps you write the initial choice as  $y_0 + a$ ; then  $a = 0$  corresponds to the choice in the text, and you see how the expressions in  $a$  are involved in the approximations. The conjecture is true for any choice of a constant (or even of a continuous function of  $x$ ).

It was mentioned in footnote 9 that Picard used his iteration for proving his existence and uniqueness theorems. Since the integrations involved in the method can be handled on the computer quite efficiently, the method has gained in importance in numerics.

### SOLUTIONS TO CHAP. 1 REVIEW QUESTIONS AND PROBLEMS, page 42

12. Linear ODE. Formula (4) in Sec. 1.5 gives, since  $p = -3, h = -3x$ ,

$$y = e^{3x} \left( \int e^{-3x}(-2x) dx + c \right) = e^{3x} \left( e^{-3x} \left( \frac{2}{3}x + \frac{2}{9} \right) + c \right) = ce^{3x} + \frac{2}{3}x + \frac{2}{9}.$$

14. Separate variables.  $y dy = 16x dx, \frac{1}{2}y^2 = 8x^2 + c^*, y^2 - 16x^2 = c$ . Hyperbolas.

16. Linear ODE. Standard form  $y' - xy = -x^3 + x$ . Use (4), Sec. 1.5, with  $p = -x, h = -x^2/2$ , obtaining the general solution

$$\begin{aligned} y &= e^{x^2/2} \left( \int e^{-x^2/2} (-x^3 + x) dx + c \right) = e^{x^2/2} [e^{-x^2/2} (x^2 + 1) + c] \\ &= ce^{x^2/2} + x^2 + 1. \end{aligned}$$

18. Exact; the exactness test gives  $-3\pi \sin \pi x \sinh 3y$  on both sides. Integrate the coefficient function of  $dx$  with respect to  $x$ , obtaining

$$u = \int M dx = \cos \pi x \cosh 3y + k(y).$$

Differentiate this with respect to  $y$  and equate the result to the coefficient function of  $dy$ :

$$u_y = 3 \cos \pi x \sinh 3y + k'(y) = N. \quad \text{Hence } k' = 0.$$

The implicit general solution is

$$\cos \pi x \cosh 3y = c.$$

20. Solvable (A) as a Bernoulli equation or (B) by separating variables.

(A) Set  $y^2 = u$  since  $a = -1$ ; hence  $1 - a = 2$ . Differentiate  $u = y^2$ , substitute  $y'$  from the given ODE, and express the resulting equation in terms of  $u$ ; that is,

$$u' = 2yy' = 2y(y + 1/y) = 2u + 2.$$

This is a linear ODE with unknown  $u$ . Its standard form is  $u' - 2u = 2$ . Solve it by (4) in Sec. 1.5 or by noting that the homogeneous ODE has the general solution  $ce^{2x}$ , and a particular solution of the nonhomogeneous ODE is  $-1$ . Hence  $u = ce^{2x} - 1$ , and  $u = y^2$ .

(B)  $y' = y + 1/y = (y^2 + 1)/y$ ,  $y \, dy/(y^2 + 1) = dx$ . Integrate and take exponents on both sides:

$$\frac{1}{2} \ln(y^2 + 1) = x + c^*, \quad y^2 + 1 = ce^{2x}.$$

22. The argument of the tangent suggests to set  $y/x = u$ . Then  $y = xu$ , and by differentiation and use of the given ODE divided by  $x$ ,

$$y' = u + xu' = \tan u + u; \quad \text{hence} \quad xu' = \tan u.$$

Separation of variables gives

$$\cot u \, du = dx/x, \quad \ln |\sin u| = \ln |x| + c^*, \quad \sin u = cx.$$

This yields the general solution

$$y = xu = x \arcsin cx.$$

24. We set  $y - 2x = z$  as indicated. Then  $y = z + 2x$ ,  $y' = z' + 2$  and by substitution into the given ODE,

$$xy' = xz' + 2x = z^2 + z + 2x.$$

Subtraction of  $2x$  on both sides gives  $xz' = z^2 + z$ . By separation of variables and integration we obtain

$$\frac{dz}{z^2 + z} = \left( \frac{1}{z} - \frac{1}{z + 1} \right) dz = \frac{dx}{x}, \quad \ln \left| \frac{z}{z + 1} \right| = \ln |x| + c^*.$$

We now take exponents and simplify algebraically. This yields

$$\frac{z}{z + 1} = \frac{y - 2x}{y - 2x + 1} = cx, \quad y = 2x + cx(y - 2x + 1).$$

Solving for  $y$ , we finally have

$$(1 - cx)y = 2x(1 - cx) + cx, \quad y = 2x - 1 + 1/(1 - cx).$$

26. The first term on the right suggests the substitution  $u = y/x$ . Then  $y = xu$ , and from the ODE,  $xy' = x(u + xu') = u^3 + xu$ . Subtract  $xu$  on both sides to get  $x^2u' = u^3$ . Separate variables and integrate:

$$u^{-3} \, du = x^{-2} \, dx, \quad -\frac{1}{2}u^{-2} = -x^{-1} + c^*; \quad \text{hence} \quad u^2 = \frac{1}{c + 2/x}.$$

This gives the general solution

$$y = \pm xu = \pm \frac{x}{\sqrt{c + 2/x}}.$$

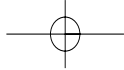

28. Logistic equation.  $y = 1/u$ ,  $y' = -u'/u^2 = 3/u - 12/u^2$ . Multiplication by  $-u^2$  gives the linear ODE

$$u' = -3u + 12. \quad \text{Solution:} \quad u = ce^{-3x} + 4.$$

Hence the general solution of the given ODE is

$$y = 1/u = 1/(ce^{-3x} + 4).$$

From the given initial condition we obtain  $y(0) = 1/(c + 4) = 2$ ; hence  $c = -3.5$ . The answer is

$$y = \frac{1}{-3.5e^{-3x} + 4}.$$

30. Linear ODE. The corresponding homogeneous ODE has the general solution  $y = ce^{-\pi x}$ . A solution of the nonhomogeneous equation can be found without integration by parts and recursion if we substitute

$$y = A \cos \pi x + B \sin \pi x \quad \text{and} \quad y' = -A\pi \sin \pi x + B\pi \cos \pi x$$

and equate the result to the right side; that is,

$$y' + \pi y = (B + A)\pi \cos \pi x + (-A + B)\pi \sin \pi x = 2b \cos \pi x.$$

This gives  $A = B = b/\pi$ . The general solution is

$$y = ce^{-\pi x} + \frac{b}{\pi} (\cos \pi x + \sin \pi x). \quad \text{Thus} \quad y(0) = c + b/\pi = 0, \quad c = -b/\pi.$$

32. Not exact; in the test we get  $2 + 2y/x$  on the left but 1 on the right. Theorem 1 in Sec. 1.4 gives an integrating factor depending only on  $x$ , namely,  $F(x) = x$ ; this follows from

$$R = \frac{1}{x + 2y} \left( 2 + \frac{2y}{x} - 1 \right) = \frac{1}{x}$$

by integrating  $R$  and taking exponents. The resulting exact equation is

$$[2xy + y^2 + e^x(1 + x)] dx + (x^2 + 2xy) dy = 0.$$

From it we calculate by integration with respect to  $y$

$$u = \int N dy = x^2y + xy^2 + l(x).$$

We differentiate this with respect to  $x$  and equate the result to the coefficient of  $dx$  in the exact ODE. This gives

$$u_x = 2xy + y^2 + l' = 2xy + y^2 + e^x(x + 1); \quad \text{hence} \quad l' = e^x(x + 1)$$

and by integration,  $l = xe^x$ . The general implicit solution is

$$u(x, y) = x^2y + xy^2 + xe^x = c.$$

From the initial condition,  $u(1, 1) = 1 + 1 + e = 2 + e$ . The particular solution of the initial value problem is

$$u(x, y) = x^2y + xy^2 + xe^x = 2 + e.$$

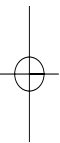

34. In problems of this sort we need two conditions, because we must determine the arbitrary constant  $c$  in the general solution and the constant  $k$  in the exponent. In the present case, these are the initial temperature  $T(0) = 10$  and the temperature  $T(5) = 20$  after 5 minutes. Newton's law of cooling gives the model

$$T' = k(T - 25).$$

By separation of variables and integration we obtain

$$T = ce^{kt} + 25.$$

The initial condition gives  $T(0) = c + 25 = 10$ ; hence  $c = -15$ . From the second given condition we obtain

$$T(5) = -15e^{5k} + 25 = 20, \quad 15e^{5k} = 5, \quad k = (\ln \frac{1}{3})/5 = -0.2197.$$

We can now determine the time when  $T$  reaches 24.9, namely, from

$$-15e^{kt} + 25 = 24.9, \quad e^{kt} = 0.1/15.$$

Hence

$$t = [\ln (0.1/15)]/k = -5.011/(-0.2197) = 23 \text{ [min]}.$$

36. This will give a **general formula** for determining the half-life  $H$  from two measurements  $y_1$  and  $y_2$  at times  $t_1$  and  $t_2$ , respectively. Accordingly, we use letters and insert the given numeric data only at the end of the derivation. We have

$$y' = ky, \quad y = y_0 e^{kt}$$

and from this

$$y_1 = y(t_1) = y_0 e^{kt_1}, \quad y_2 = y(t_2) = y_0 e^{kt_2}.$$

Taking the quotient of the two measurements  $y_1$  and  $y_2$  eliminates  $y_0$  (the initial amount) and gives a formula for  $k$  in terms of these measurements and the corresponding times, namely,

$$y_2/y_1 = \exp [k(t_2 - t_1)], \quad k = \frac{\ln (y_2/y_1)}{t_2 - t_1}.$$

Knowing  $k$ , we can now readily determine the half-life  $H$  directly from its definition

$$e^{kH} = 0.5.$$

This gives

$$H = \frac{\ln 0.5}{k} = (\ln 0.5) \frac{t_2 - t_1}{\ln (y_2/y_1)}.$$

For the given data we obtain from this formula

$$H = -0.69315 \frac{10 - 5}{\ln (0.015/0.02)} = 12.05.$$

Thus the half-life of the substance is about 12 days and 1 hour.

38. Let  $y$  denote the amount of fresh air measured in cubic feet. Then the model is obtained from the balance equation

$$\text{"Inflow minus Outflow equals the rate of change"};$$

that is,

$$y' = 600 - \frac{600}{20000} y = 600 - 0.03y.$$

The general solution of this linear ODE is

$$y = ce^{-0.03t} + 20000.$$

The initial condition is  $y(0) = 0$  (initially no fresh air) and gives

$$y(0) = c + 20000 = 0; \quad \text{hence} \quad c = -20000.$$

The particular solution of our problem is

$$y = 20000(1 - e^{-0.03t}).$$

This equals 90% if  $t$  is such that

$$e^{-0.03t} = 0.1$$

thus if  $t = (\ln 0.1)/(-0.03) = 77$  [min].

40. We use separation of variables. To evaluate the integral, we apply reduction by partial fractions. This yields

$$\frac{dy}{(a-y)(b-y)} = \left[ \frac{A}{y-a} + \frac{B}{y-b} \right] dy = k dx,$$

where

$$A = \frac{1}{a-b} \quad \text{and} \quad B = \frac{1}{b-a} = -A.$$

By integration,

$$A[\ln |y-a| - \ln |y-b|] = A \ln \left| \frac{y-a}{y-b} \right| = kt + c^*.$$

We multiply this on both sides by  $1/A = a-b$ , obtaining

$$\ln \left| \frac{y-a}{y-b} \right| = (kt + c^*)(a-b).$$

We now take exponents. In doing so, we can set  $c = e^{c^*}$  and have

$$\frac{y-a}{y-b} = ce^{(a-b)kt}.$$

We denote the right side by  $E$  and solve algebraically for  $y$ ; then

$$y-a = (y-b)E, \quad y(1-E) = a-bE$$

and from the last expression we finally have

$$y = \frac{a-bE}{1-E}.$$

42. Let the tangent of such a curve  $y(x)$  at  $(x, y)$  intersect the  $x$ -axis at  $M$  and the  $y$ -axis at  $N$ , as shown in the figure. Then because of the bisection we have

$$OM = 2x, \quad ON = 2y,$$

where  $O$  is the origin. Since the slope of the tangent is the slope  $y'(x)$  of the curve, by the definition of a tangent, we obtain

$$y' = -ON/OM = -y/x.$$

By separation of variables, integration, and taking exponents, we see that

$$\frac{dy}{y} = -\frac{dx}{x}, \quad \ln |y| = -\ln |x| + c^*, \quad xy = c.$$

This is a family of hyperbolas.

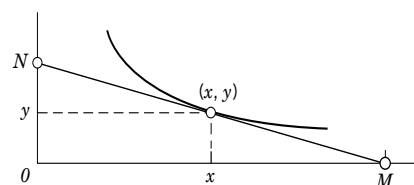

**Section 1.7.** Problem 42

## CHAPTER 2 Second-Order Linear ODEs

### Major Changes

Among linear ODEs those of second order are by far the most important ones from the viewpoint of applications, and from a theoretical standpoint they illustrate the theory of linear ODEs of any order (except for the role of the Wronskian). For these reasons we consider linear ODEs of third and higher order in a separate chapter, Chap. 3.

The new Sec. 2.2 combines all three cases of the roots of the characteristic equation of a homogeneous linear ODE with constant coefficients. (In the last edition the complex case was discussed in a separate section.)

Modeling applications of the method of undetermined coefficients (Sec. 2.7) follow immediately after the derivation of the method (mass–spring systems in Sec. 2.8, electric circuits in Sec. 2.9), before the discussion of variation of parameters (Sec. 2.10).

The new Sec. 2.9 combines the old Sec. 1.7 on modeling electric circuits by first-order ODEs and the old Sec. 2.12 on electric circuits modeled by second-order ODEs. This avoids discussing the physical aspects and foundations twice.

### SECTION 2.1. Homogeneous Linear ODEs of Second-Order, page 45

**Purpose.** To extend the basic concepts from first-order to second-order ODEs and to present the basic properties of linear ODEs.

#### Comment on the Standard Form (1)

The form (1), with 1 as the coefficient of  $y''$ , is practical, because if one starts from

$$f(x)y'' + g(x)y' + h(x)y = \tilde{r}(x),$$

one usually considers the equation in an interval  $I$  in which  $f(x)$  is nowhere zero, so that in  $I$  one can divide by  $f(x)$  and obtain an equation of the form (1). Points at which  $f(x) = 0$  require a special study, which we present in Chap. 5.

#### Main Content, Important Concepts

Linear and nonlinear ODEs

Homogeneous linear ODEs (to be discussed in Secs. 2.1–2.6)

Superposition principle for homogeneous ODEs

General solution, basis, linear independence

Initial value problem (2), (4), particular solution

Reduction to first order (text and Probs. 15–22)

#### Comment on the Three ODEs after (2)

These are for illustration, not for solution, but should a student ask, answers are that the first will be solved by methods in Sec. 2.7 and 2.10, the second is a Bessel equation (Sec. 5.5) and the third has the solutions  $\pm\sqrt{c_1x + c_2}$  with any  $c_1$  and  $c_2$ .

#### Comment on Footnote 1

In 1760, Lagrange gave the first methodical treatment of the calculus of variations. The book mentioned in the footnote includes all major contributions of others in the field and made him the founder of analytical mechanics.



**Comment on Terminology**

$p$  and  $q$  are called the **coefficients** of (1) and (2). The function  $r$  on the right is *not* called a coefficient, to avoid the misunderstanding that  $r$  must be constant when we talk about an ODE *with constant coefficients*.

**SOLUTIONS TO PROBLEM SET 2.1, page 52**

2.  $\cos 5x$  and  $\sin 5x$  are linearly independent on any interval because their quotient,  $\cot 5x$ , is not constant. General solution:

$$y = a \cos 5x + b \sin 5x.$$

We also need the derivative

$$y' = -5a \sin 5x + 5b \cos 5x.$$

At  $x = 0$  we have from this and the initial conditions

$$y(0) = a = 0.8, \quad y'(0) = 5b = -6.5, \quad b = -1.3.$$

Hence the solution of the initial value problem is

$$y = 0.8 \cos 5x - 1.3 \sin 5x.$$

4.  $e^{3x}$  and  $xe^{3x}$  form a linearly independent set on any interval because  $xe^{3x}/e^{3x} = x$  is not constant. The corresponding general solution is

$$y = (c_1x + c_2)e^{3x}$$

and has the derivative

$$y' = (c_1 + 3c_1x + 3c_2)e^{3x}.$$

From this and the initial conditions we obtain

$$y(0) = c_2 = -1.4, \quad y'(0) = c_1 + 3c_2 = c_1 - 4.2 = 4.6, \quad c_1 = 8.8.$$

The *answer* is the particular solution

$$y = (8.8x - 1.4)e^{3x}.$$

6. This is an example of an Euler–Cauchy equation  $x^2y'' + axy' + by = 0$ , which we shall consider systematically in Sec. 2.5. Substitution shows that  $x^3$  and  $x^5$  are solutions of the given ODE, and they are linearly independent on any interval because their quotient  $x^5/x^3 = x^2$  is not constant. Hence the corresponding general solution is

$$y = c_1x^3 + c_2x^5.$$

Its derivative is

$$y' = 3c_1x^2 + 5c_2x^4.$$

From this and the initial conditions we have

$$y(1) = c_1 + c_2 = 0.4, \quad y'(1) = 3c_1 + 5c_2 = 1.0.$$

Hence  $c_1 = 0.5$  and  $c_2 = -0.1$ , so that the solution (the particular solution satisfying the initial conditions) is (see the figure)

$$y = 0.5x^3 - 0.1x^5.$$

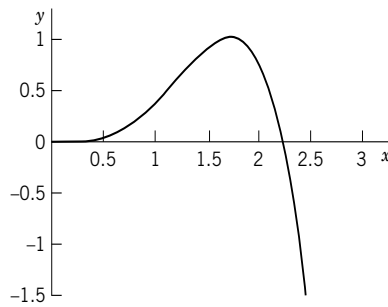

Section 2.1. Problem 6

8. Yes when  $n \neq 2$ . Emphasize that we also have linear independence when  $n = 0$ .

The intervals given in Probs. 7–14 serve as reminder that linear independence and dependence always refer to an interval, never just to a single point, and they also help exclude points at which one of the functions is not defined.

Linear independence is important in connection with general solutions, and these problems are such that the computer is of no great help.

The functions are selected as they will occur in some of the later work. They also encourage the student to think of functional relations between those functions. For instance,  $\ln x^2 = 2 \ln x$  in Prob. 11 and the formula for  $\sin 2x$  in Prob. 13 help in obtaining the right answer (linear dependence).

10. Yes. The relation  $\cos^2 x + \sin^2 x = 1$  is irrelevant here.

12. Yes. Consider the quotient.

14. No. Once and for all, we have linear dependence of two (or more) functions if one of them is identically 0. This problem is important.

16. 
$$y'' = \frac{dy'}{dx} = \frac{dy'}{dy} \frac{dy}{dx} = \frac{dz}{dy} z$$

18.  $z' = 1 + z^2$ ,  $dz/(1 + z^2) = dx$ ,  $\arctan z = x + c_1$ ,  $z = \tan(x + c_1)$ ,  
 $y = -\ln |\cos(x + c_1)| + c_2$

This is an obvious use of problems from Chap. 1 in setting up problems for this section. The only difficulty may be an unpleasant additional integration.

20. The formula in the text was derived under the assumption that the ODE is in standard form; in the present case,

$$y'' + \frac{2}{x} y' + y = 0.$$

Hence  $p = 2/x$ , so that  $e^{-\int p dx} = x^{-2}$ . It follows from (9) in the text that

$$U = \frac{x^2}{\cos^2 x} \cdot \frac{1}{x^2} = \frac{1}{\cos^2 x}.$$

The integral of  $U$  is  $\tan x$ ; we need no constants of integration because we merely want to obtain a particular solution. The *answer* is

$$y_2 = y_1 \tan x = \frac{\sin x}{x}.$$

22. The standard form is

$$y'' - \frac{2x}{1-x^2} y' + \frac{2}{1-x^2} y = 0.$$

Hence in (9) we have

$$-\int p \, dx = \int \frac{2x}{1-x^2} \, dx = -\ln|1-x^2| = \ln \left| \frac{1}{1-x^2} \right|.$$

This gives, in terms of partial fractions,

$$U = \frac{1}{x^2} \cdot \frac{1}{1-x^2} = \frac{1}{x^2} + \frac{1/2}{x+1} - \frac{1/2}{x-1}.$$

By integration we get the *answer*

$$y_2 = y_1 u = y_1 \int U \, dx = -1 + \frac{1}{2}x \ln \left| \frac{x+1}{x-1} \right|.$$

The equation is Legendre's equation with parameter  $n = 1$  (as, of course, need *not* be mentioned to the student), and the solution is essentially a Legendre function. This problem shows the usefulness of the reduction method because it is not difficult to see that  $y_1 = x$  is a solution. In contrast, the power series method (the standard method) would give the second solution as an infinite series, whereas by our present method we get the solution directly, bypassing infinite series in the present special case  $n = 1$ .

Also note that the transition to  $n = 2, 3, \dots$  is not very complicated because  $U$  depends only on the coefficient  $p$  of the ODE, which remains the same for all  $n$ , since  $n$  appears only in the last term of the ODE. Hence if we want the answer for other  $n$ , all we have to do is insert another Legendre polynomial for  $y_1$  instead of the present  $y_1 = x$ .

24.  $z' = (1+z^2)^{1/2}$ ,  $(1+z^2)^{-1/2} dz = dx$ ,  $\operatorname{arcsinh} z = x + c_1$ . From this,  $z = \sinh(x + c_1)$ ,  $y = \cosh(x + c_1) + c_2$ . From the boundary conditions  $y(1) = 0$ ,  $y(-1) = 0$  we get

$$\cosh(1 + c_1) + c_2 = 0 = \cosh(-1 + c_1) + c_2.$$

Hence  $c_1 = 0$  and then  $c_2 = -\cosh 1$ . The *answer* is (see the figure)

$$y = \cosh x - \cosh 1.$$

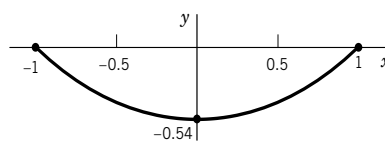

Section 2.1. Problem 24

## SECTION 2.2. Homogeneous Linear ODEs with Constant Coefficients, page 53

**Purpose.** To show that homogeneous linear ODEs with constant coefficients can be solved by algebra, namely, by solving the quadratic characteristics equation (3). The roots may be:

- (Case I) Real distinct roots
- (Case II) A real double root (“Critical case”)
- (Case III) Complex conjugate roots.

In Case III the roots are conjugate because the coefficients of the ODE, and thus of (3), are real, a fact the student should remember.

To help poorer students, we have shifted the derivation of the real form of the solutions in Case III to the end of the section, but the verification of these real solutions is done immediately when they are introduced. This will also help to a better understanding.

The student should become aware of the fact that Case III includes both undamped (harmonic) oscillations (if  $c = 0$ ) and damped oscillations.

Also it should be emphasized that in the transition from the complex to the real form of the solutions we use the superposition principle.

Furthermore, one should emphasize the general importance of the Euler formula (11), which we shall use on various occasions.

### Comment on How to Avoid Working in Complex

The average engineering student will profit from working a little with complex numbers. However, if one has reasons for avoiding complex numbers here, one may apply the method of eliminating the first derivative from the equation, that is, substituting  $y = uv$  and determining  $v$  so that the equation for  $u$  does not contain  $u'$ . For  $v$  this gives

$$2v' + av = 0. \quad \text{A solution is } v = e^{-ax/2}.$$

With this  $v$ , the equation for  $u$  takes the form

$$u'' + (b - \frac{1}{4}a^2)u = 0$$

and can be solved by remembering from calculus that  $\cos \omega x$  and  $\sin \omega x$  reproduce under two differentiations, multiplied by  $-\omega^2$ . This gives (9), where

$$\omega = \sqrt{b - \frac{1}{4}a^2}.$$

Of course, *the present approach can be used to handle all three cases*. In particular,  $u'' = 0$  in Case II gives  $u = c_1 + c_2x$  at once.

### SOLUTIONS TO PROBLEM SET 2.2, page 59

2. The standard form is

$$y'' - 0.7y' + 0.12y = 0.$$

The characteristic equation

$$\lambda^2 - 0.7\lambda + 0.12 = (\lambda - 0.4)(\lambda - 0.3) = 0$$

has the roots 0.4 and 0.3, so that the corresponding general solution is

$$y_1 = c_1 e^{0.4x} + c_2 e^{0.3x}.$$

4. The characteristic equation  $\lambda^2 + 4\pi\lambda + 4\pi^2 = (\lambda + 2\pi)^2 = 0$  has the double root  $-2\pi$ , so that the corresponding general solution is

$$y = (c_1 + c_2x)e^{-2\pi x}.$$

6. The characteristic equation  $\lambda^2 + 2\lambda + 5 = (\lambda + 1)^2 + 4 = 0$  has the roots  $-1 \pm 2i$ , so that the general solution is

$$y = e^{-x}(A \cos 2x + B \sin 2x).$$

8. The characteristic equation is  $\lambda^2 + 2.6\lambda + 1.69 = (\lambda + 1.3)^2 = 0$ , so that we obtain the general solution

$$y = (c_1 + c_2x)e^{-1.3x}.$$

10. From the characteristic equation  $\lambda^2 - 2 = (\lambda + \sqrt{2})(\lambda - \sqrt{2}) = 0$  we see that the corresponding general solution is

$$y = c_1 e^{-x\sqrt{2}} + c_2 e^{x\sqrt{2}}$$

12. The characteristic equation  $\lambda^2 + 2.4\lambda + 4 = (\lambda + 1.2)^2 + 1.6^2 = 0$  has the roots  $-1.2 \pm 1.6i$ . The corresponding general solution is

$$y = e^{-1.2x}(A \cos 1.6x + B \sin 1.6x).$$

14. The characteristic equation  $\lambda^2 + \lambda - 0.96 = (\lambda - 0.6)(\lambda + 1.6) = 0$  has the roots 0.6 and  $-1.6$  and thus gives the general solution

$$y = c_1 e^{0.6x} + c_2 e^{-1.6x}.$$

16. To the given basis there corresponds the characteristic equation

$$(\lambda - 0.5)(\lambda + 3.5) = \lambda^2 + 3\lambda - 1.75 = 0.$$

The corresponding ODE is

$$y'' + 3y' - 1.75y = 0.$$

18. The characteristic equation  $\lambda(\lambda + 3) = \lambda^2 + 3\lambda = 0$  gives the ODE  $y'' + 3y' = 0$ .

20. We see that the characteristic equation is

$$(\lambda + 1 - i)(\lambda + 1 + i) = \lambda^2 + 2\lambda + 2 = 0$$

and obtain from it the ODE

$$y'' + 2y' + 2y = 0.$$

22. From the characteristic equation

$$\lambda^2 + 2\lambda + 1 = (\lambda + 1)^2 = 0$$

we obtain the general solution

$$y = (c_1 + c_2 x)e^{-x}.$$

Its derivative is

$$y' = (c_2 - c_1 - c_2 x)e^{-x}.$$

Setting  $x = 0$ , we obtain

$$y(0) = c_1 = 4, \quad y'(0) = c_2 - c_1 = c_2 - 4 = -6, \quad c_2 = -2.$$

This gives the particular solution

$$y = (4 - 2x)e^{-x}.$$

24. The characteristic equation is

$$10\lambda^2 - 50\lambda + 65 = 10[\lambda^2 - 5\lambda + 6.5] = 10[(\lambda - 2.5)^2 + 0.25] = 0.$$

Hence a general solution is

$$y = e^{2.5x}(A \cos 0.5x + B \sin 0.5x) \quad \text{and} \quad y(0) = A = 1.5.$$

From this we obtain the derivative

$$y' = e^{2.5x}(2.5 \cdot 1.5 \cos 0.5x + 2.5B \sin 0.5x - 0.75 \sin 0.5x + 0.5B \cos 0.5x).$$

From this and the second initial condition we obtain

$$y'(0) = 3.75 + 0.5B = 1.5; \quad \text{hence} \quad B = -4.5.$$

The *answer* is

$$y = e^{2.5x}(1.5 \cos 0.5x - 4.5 \sin 0.5x).$$

26. Dividing the ODE by 10 to get the standard form, we see that the characteristic equation is

$$\lambda^2 + 1.8\lambda + 0.56 = (\lambda + 0.4)(\lambda + 1.4) = 0.$$

Hence a general solution is

$$y = c_1 e^{-0.4x} + c_2 e^{-1.4x}.$$

Now  $y(0) = c_1 + c_2 = 4$  from the first initial condition, and by differentiation and from the second initial condition,

$$-0.4c_1 - 1.4c_2 = -3.8.$$

The solution of this system of equations is  $c_1 = 1.8$ ,  $c_2 = 2.2$ . Hence the initial value problem has the solution

$$y = 1.8e^{-0.4x} + 2.2e^{-1.4x}.$$

28. The roots of the characteristic equation  $\lambda^2 - 9 = 0$  are 3 and  $-3$ . Hence a general solution is

$$y = c_1 e^{-3x} + c_2 e^{3x}.$$

Now  $c_1 + c_2 = -2$  from the first initial condition. By differentiation and from the second initial condition,  $-3c_1 + 3c_2 = -12$ . The solution of these two equations is  $c_1 = 1$ ,  $c_2 = -3$ . Hence the *answer* is

$$y = e^{-3x} - 3e^{3x}.$$

30. The characteristic equation is

$$\lambda^2 + 2k\lambda + (k^2 + \omega^2) = (\lambda + k)^2 + \omega^2 = 0.$$

Its roots are  $-k \pm i\omega$ . Hence a general solution is

$$y = e^{-kx}(A \cos \omega x + B \sin \omega x).$$

For  $x = 0$  this gives  $y(0) = A = 1$ . With this value of  $A$  the derivative is

$$y' = e^{-kx}(-k \cos \omega x - Bk \sin \omega x - \omega \sin \omega x + B\omega \cos \omega x).$$

For  $x = 0$  we obtain from this and the second initial condition

$$y'(0) = -k + B\omega = -k; \quad \text{hence} \quad B = 0.$$

The *answer* is

$$y = e^{-kx} \cos \omega x.$$

32. The characteristic equation is  $\lambda^2 - 2\lambda - 24 = (\lambda - 6)(\lambda + 4) = 0$ . This gives as a general solution

$$y = c_1 e^{6x} + c_2 e^{-4x}.$$

Hence  $y(0) = c_1 + c_2 = 0$ , and by differentiation,  $6c_1 - 4c_2 = y'(0) = 20$ . The *answer* is

$$y = 2e^{6x} - 2e^{-4x}.$$

**34. Team Project. (A)** We obtain

$$(\lambda - \lambda_1)(\lambda - \lambda_2) = \lambda^2 - (\lambda_1 + \lambda_2)\lambda + \lambda_1\lambda_2 = \lambda^2 + a\lambda + b = 0.$$

Comparison of coefficients gives  $a = -(\lambda_1 + \lambda_2)$ ,  $b = \lambda_1\lambda_2$ .

**(B)**  $y'' + ay' = 0$ . (i)  $y = c_1e^{-ax} + c_2e^{0x} = c_1e^{-ax} + c_2$ . (ii)  $z' + az = 0$ , where  $z = y'$ ,  $z = ce^{-ax}$  and the second term comes in by integration:

$$y = \int z \, dx = \tilde{c}_1e^{-ax} + \tilde{c}_2.$$

**(D)**  $e^{(k+m)x}$  and  $e^{kx}$  satisfy  $y'' - (2k + m)y' + k(k + m)y = 0$ , by the coefficient formulas in part (A). By the superposition principle, another solution is

$$\frac{e^{(k+m)x} - e^{kx}}{m}.$$

We now let  $m \rightarrow 0$ . This becomes  $0/0$ , and by l'Hôpital's rule (differentiation of numerator and denominator separately with respect to  $m$ , not  $x$ !) we obtain

$$xe^{kx}/1 = xe^{kx}.$$

The ODE becomes  $y'' - 2ky' + k^2y = 0$ . The characteristic equation is

$$\lambda^2 - 2k\lambda + k^2 = (\lambda - k)^2 = 0$$

and has a double root. Since  $a = -2k$ , we get  $k = -a/2$ , as expected.

**SECTION 2.3. Differential Operators. Optional, page 59**

**Purpose.** To take a short look at the operational calculus of second-order differential operators with constant coefficients, which parallels and confirms our discussion of ODEs with constant coefficients.

**SOLUTIONS TO PROBLEM SET 2.3, page 61**

2.  $(8D^2 + 2D - I)(\cosh \frac{1}{2}x) = 8 \cdot \frac{1}{4} \cosh \frac{1}{2}x + 2 \cdot \frac{1}{2} \sinh \frac{1}{2}x - \cosh \frac{1}{2}x = e^{x/2}$ . The same result is obtained for  $\sinh \frac{1}{2}x$ . By addition of these two results we obtain the result  $2e^{x/2}$  for  $e^{x/2}$ .

4.  $(D + 5I)(D - I) = (D - I)(D + 5I)$ , and

$$\begin{aligned} (D - I)(D + 5I)(e^{-5x} \sin x) &= (D - I)(-5e^{-5x} \sin x + e^{-5x} \cos x + 5e^{-5x} \sin x) \\ &= (D - I)(e^{-5x} \cos x) \\ &= -6e^{-5x} \cos x - e^{-5x} \sin x. \end{aligned}$$

For the second given function the answer is  $40e^{5x}$  and for the third it is  $-5x^2 + 8x + 2$ .

6.  $(D - 3.7I)(D - 1.8I)$ ,  $y = c_1e^{3.7x} + c_2e^{1.8x}$

8.  $(D - 0.7I)(D + 0.7I)$ ,  $y = c_1e^{0.7x} + c_2e^{-0.7x}$

10.  $(D + (0.1 + 0.4i)I)(D + (0.1 - 0.4i)I)$ ,  $y = e^{-0.1x}(A \cos 0.4x + B \sin 0.4x)$

12.  $4(D + \frac{1}{2}\pi I)^2$ ,  $y = (c_1 + c_2x)e^{-\pi x/2}$

14.  $y$  is a solution, as follows from the superposition principle in Sec. 2.1 because the ODE is homogeneous linear. In the application of l'Hôpital's rule,  $y$  is regarded as a function of  $\mu$ , the variable that is approaching the limit, whereas  $\lambda$  is fixed.

Accordingly, differentiation of the numerator with respect to  $\mu$  gives  $xe^{\mu x} - 0$ , and differentiation of the denominator gives 1. The limit of this is  $xe^{\lambda x}$ .

16. The two conditions follow trivially from the condition in the text. Conversely, by combining the two conditions we have

$$L(cy + kw) = L(cy) + L(kw) = cLy + kLw.$$

## SECTION 2.4. Modeling: Free Oscillations (Mass–Spring System), page 61

**Purpose.** To present a main application of second-order constant-coefficient ODEs

$$my'' + cy' + ky = 0$$

resulting as models of motions of a mass  $m$  on an elastic spring of modulus  $k$  ( $> 0$ ) under linear damping  $c$  ( $\geq 0$ ) by applying Newton's second law and Hooke's law. These are free motions (no driving force). Forced motions follow in Sec. 2.8.

This system should be regarded as a basic building block of more complicated systems, a prototype of a vibrating system that shows the essential features of more sophisticated systems as they occur in various forms and for various purposes in engineering.

The quantitative agreement between experiments of the physical system and its mathematical model is surprising. Indeed, the student should not miss performing experiments if there is an opportunity, as I had as a student of Prof. Blaess, the inventor of a (now obscure) graphical method for solving ODEs.

### Main Content, Important Concepts

Restoring force  $ky$ , damping force  $cy'$ , force of inertia  $my''$

No damping, harmonic oscillations (4), natural frequency  $\omega_0/(2\pi)$

Overdamping, critical damping, nonoscillatory motions (7), (8)

Underdamping, damped oscillations (10)

## SOLUTIONS TO PROBLEM SET 2.4, page 68

2. (i)  $\sqrt{k_1/m}/(2\pi) = 3/(2\pi)$ , (ii)  $5/(2\pi)$

(iii) Let  $K$  denote the modulus of the springs in parallel. Let  $F$  be some force that stretches the combination of springs by an amount  $s_0$ . Then  $F = Ks_0$ . Let  $k_1s_0 = F_1$ ,  $k_2s_0 = F_2$ . Then

$$F = F_1 + F_2 = (k_1 + k_2)s_0.$$

By comparison,  $K = k_1 + k_2 = 102$  [nt/m],  $\sqrt{K/m}/(2\pi) = \sqrt{34}/(2\pi) = 5.83/(2\pi)$ .

(iv) Let  $F = k_1s_1$ ,  $F = k_2s_2$ . Then if we attach the springs in series, the extensions  $s_1$  and  $s_2$  under  $F$  add, so that  $F = k(s_1 + s_2)$ , where  $k$  is the modulus of the combination. Substitution of  $s_1$  and  $s_2$  from the other two equations gives

$$F = k(F/k_1 + F/k_2).$$

Division by  $kF$  gives

$$1/k = 1/k_1 + 1/k_2, \quad k = k_1k_2/(k_1 + k_2) = 19.85.$$

Hence the frequency is

$$f = \sqrt{k/m}/(2\pi) = \sqrt{6.62}/(2\pi) = 2.57/(2\pi).$$



4.  $mg = ks_0$  by Hooke's law. Hence  $k = mg/s_0$ , and

$$f = (1/2\pi)\sqrt{k/m} = (1/2\pi)\sqrt{mg/s_0m} = (1/2\pi)\sqrt{g/s_0} = (1/2\pi)\sqrt{9.80/0.1}.$$

The numeric value of the last expression is  $1.58 \text{ sec}^{-1}$ , approximately; here,  $s_0 = 10 \text{ cm} = 0.1 \text{ m}$  is given.

6.  $my'' = -\pi \cdot 0.3^2 y \gamma$ , where  $\pi \cdot 0.3^2 y$  is the volume of water displaced when the buoy is depressed  $y$  meters from its equilibrium position, and  $\gamma = 9800 \text{ nt}$  is the weight of water per cubic meter. Thus  $y'' + \omega_0^2 y = 0$ , where  $\omega_0^2 = \pi \cdot 0.3^2 \gamma/m$  and the period is  $2\pi/\omega_0 = 2$ ; hence

$$m = \pi \cdot 0.3^2 \gamma / \omega_0^2 = 0.3^2 \gamma / \pi = 281$$

$$W = mg = 281 \cdot 9.80 = 2754 \text{ [nt]} \quad (\text{about } 620 \text{ lb}).$$

8. **Team Project.** (a)  $W = ks_0 = 25$ ,  $s_0 = 2$ ,  $m = W/g$ , and

$$\omega_0 = \sqrt{k/m} = \sqrt{(W/s_0)/(W/g)} = \sqrt{980/2} = 22.14.$$

This gives the general solution

$$y = A \cos 22.14t + B \sin 22.14t.$$

Now  $y(0) = A = 0$ ,  $y' = 22.14B \cos 22.14t$ ,  $y'(0) = 22.14B = 15$ ,  $B = 0.6775$ . Hence the particular solution satisfying the given initial conditions is

$$y = 0.6775 \sin 22.14t \text{ [cm]}.$$

- (b)  $\omega_0 = \sqrt{K/I_0} = \sqrt{17.64} = 4.2 \text{ sec}^{-1}$ . Hence a general solution is

$$\theta = A \cos 4.2t + B \sin 4.2t.$$

The derivative is

$$\theta' = -4.2A \sin 4.2t + 4.2B \cos 4.2t.$$

The initial conditions give  $\theta(0) = A = \pi/4 = 0.7854 \text{ rad}$  ( $45^\circ$ ) and

$$\theta'(0) = \pi/12 = 0.2618 \text{ rad} \cdot \text{sec}^{-1} \text{ (} 15^\circ \text{sec}^{-1}\text{)}, \text{ hence } B = 0.2618/4.2 = 0.0623.$$

The *answer* is

$$\theta = 0.7854 \cos 4.2t + 0.0623 \sin 4.2t.$$

(c) The force of inertia in Newton's second law is  $my''$ , where  $m = 5 \text{ kg}$  is the mass of the water. The dark blue portion of the water in Fig. 45, a column of height  $2y$ , is the portion that causes the restoring force of the vibration. Its volume is  $\pi \cdot 0.02^2 \cdot 2y$ . Hence its weight is  $\pi \cdot 0.02^2 \cdot 2y\gamma$ , where  $\gamma = 9800 \text{ nt}$  is the weight of water per cubic meter. This gives the ODE

$$y'' + \omega_0^2 y = 0$$

where

$$\omega_0^2 = \frac{\pi \cdot 0.02^2 \cdot 2 \cdot \gamma}{5} = 0.0005027\gamma = 4.926$$

and  $\omega_0 = 2.219$ . Hence the corresponding general solution is

$$y = A \cos 2.219t + B \sin 2.219t.$$

The frequency is  $\omega_0/(2\pi) = 0.353 \text{ [sec}^{-1}\text{]}$ , so that the water makes about 20 oscillations per minute, or one cycle in about 3 sec.

10.  $y' = e^{-2t}(-2 \cos t - \sin t) = 0$ ,  $\tan t = -2$ ,  $t = 2.0344 + n\pi$ ,  $n = 0, 1, \dots$ .
12. If an extremum is at  $t_0$ , the next one is at  $t_1 = t_0 + \pi/\omega^*$ , by Prob. 11. Since the cosine and sine in (10) have period  $2\pi/\omega^*$ , the amplitude ratio is

$$\exp(-\alpha t_0)/\exp(-\alpha t_1) = \exp(-\alpha(t_0 - t_1)) = \exp(\alpha\pi/\omega^*).$$

The natural logarithm is  $\alpha\pi/\omega^*$ , and maxima alternate with minima. Hence  $\Delta = 2\pi\alpha/\omega^*$  follows.

$$\text{For the ODE, } \Delta = 2\pi \cdot 1/(\frac{1}{2}\sqrt{4 \cdot 5 - 2^2}) = \pi.$$

14.  $2\pi/\omega^* = 2$  sec;  $\omega^* = \pi$ . The time for 15 cycles is  $t = 30$  sec. The quotient of the corresponding amplitudes at  $t_0$  and  $t_0 + 30$  is

$$e^{-\alpha(t_0+30)}/e^{-\alpha t_0} = e^{-\alpha \cdot 30} = 0.25.$$

Thus  $e^{30\alpha} = 4$ ,  $\alpha = (\ln 4)/30 = 0.0462$ . Now  $\alpha = c/(2m) = c/4$ ; hence  $c = 4\alpha = 0.1848$ .

To check this, use  $\omega^{*2} \cdot 4m^2 = 4mk - c^2$  by (9) which gives

$$k = \frac{1}{4m} (4m^2\omega^{*2} + c^2) = \frac{1}{4m} (4m^2\pi^2 + c^2) = 19.74,$$

and solve  $2y'' + 0.1848y' + 19.74y = 0$  to get

$$y = e^{-0.0462t}(A \cos 3.14t + B \sin 3.14t) \quad \text{and} \quad e^{-0.0462 \cdot 30} = \frac{1}{4}.$$

16.  $y = c_1 e^{-(\alpha-\beta)t} + c_2 e^{-(\alpha+\beta)t}$ ,  $y(0) = c_1 + c_2 = y_0$ . By differentiating and setting  $t = 0$  it follows that

$$y'(0) = (-\alpha + \beta)c_1 + (-\alpha - \beta)c_2 = v_0.$$

From the first equation,  $c_2 = y_0 - c_1$ . By substitution and simplification,

$$(-\alpha + \beta)c_1 + (-\alpha - \beta)(y_0 - c_1) = v_0$$

$$c_1(-\alpha + \beta + \alpha + \beta) = v_0 + (\alpha + \beta)y_0.$$

This yields the *answer*

$$c_1 = [(\alpha + \beta)y_0 + v_0]/(2\beta), \quad c_2 = [(\beta - \alpha)y_0 - v_0]/(2\beta).$$

18. **CAS Project. (a)** The three cases appear, along with their typical solution curves, regardless of the numeric values of  $k/m$ ,  $y(0)$ , etc.

**(b)** The first step is to see that Case II corresponds to  $c = 2$ . Then we can choose other values of  $c$  by experimentation. In Fig. 46 the values of  $c$  (omitted on purpose; the student should choose!) are 0 and 0.1 for the oscillating curves, 1, 1.5, 2, 3 for the others (from below to above).

**(c)** This addresses a general issue arising in various problems involving heating, cooling, mixing, electrical vibrations, and the like. One is generally surprised how quickly certain states are reached whereas the theoretical time is infinite.

**(d)** General solution  $y(t) = e^{-ct/2}(A \cos \omega^*t + B \sin \omega^*t)$ , where  $\omega^* = \frac{1}{2}\sqrt{4 - c^2}$ . The first initial condition  $y(0) = 1$  gives  $A = 1$ . For the second initial condition we need the derivative (we can set  $A = 1$ )

$$y'(t) = e^{-ct/2} \left( -\frac{c}{2} \cos \omega^*t - \frac{c}{2} B \sin \omega^*t - \omega^* \sin \omega^*t + \omega^* B \cos \omega^*t \right).$$

From this we obtain  $y'(0) = -c/2 + \omega^*B = 0$ ,  $B = c/(2\omega^*) = c/\sqrt{4 - c^2}$ . Hence the particular solution (with  $c$  still arbitrary,  $0 < c < 2$ ) is

$$y(t) = e^{-ct/2} \left( \cos \omega^*t + \frac{c}{\sqrt{4 - c^2}} \sin \omega^*t \right).$$

Its derivative is, since the cosine terms drop out,

$$\begin{aligned} y'(t) &= e^{-ct/2} (-\sin \omega^*t) \left( \frac{c^2}{2\sqrt{4 - c^2}} + \frac{1}{2} \sqrt{4 - c^2} \right) \\ &= \frac{-2}{\sqrt{4 - c^2}} e^{-ct/2} \sin \omega^*t. \end{aligned}$$

The tangent of the  $y$ -curve is horizontal when  $y' = 0$ , for the first positive time when  $\omega^*t = \pi$ , thus  $t = t_2 = \pi/\omega^* = 2\pi/\sqrt{4 - c^2}$ . Now the  $y$ -curve oscillates between  $\pm e^{-ct/2}$ , and (11) is satisfied if  $e^{-ct/2}$  does not exceed 0.001. Thus  $ct = 2 \ln 1000$ , and  $t = t_2$  gives the best  $c$  satisfying (11). Hence

$$c = (2 \ln 1000)/t_2, \quad c^2 = \frac{(\ln 1000)^2}{\pi^2} (4 - c^2).$$

The solution of this is  $c = 1.821$ , approximately. For this  $c$  we get by substitution  $\omega^* = 0.4141$ ,  $t_2 = 7.587$ , and the particular solution

$$y(t) = e^{-0.9103t} (\cos 0.4141t + 2.199 \sin 0.4141t).$$

The graph shows a positive maximum near 15, a negative minimum near 23, a positive maximum near 30, and another negative minimum at 38.

(e) The main difference is that Case II gives

$$y = (1 - t)e^{-t}$$

which is negative for  $t > 1$ . The experiments with the curves are as before in this project.

## SECTION 2.5. Euler–Cauchy Equations, page 69

**Purpose.** Algebraic solution of the Euler–Cauchy equation, which appears in certain applications (see our Example 4) and which we shall need again in Sec. 5.4 as the simplest equation to which the Frobenius method applies. We have three cases; this is similar to the situation for constant-coefficient equations, to which the Euler–Cauchy equation can be transformed (Team Project 16); however, this fact is of theoretical rather than of practical interest.

### Comment on Footnote 4

Euler worked in St. Petersburg 1727–1741 and 1766–1783 and in Berlin 1741–1766. He investigated Euler's constant (Sec. 5.6) first in 1734, used Euler's formula (Secs. 2.2, 13.5, 13.6) beginning in 1740, introduced integrating factors (Sec. 1.4) in 1764, and studied conformal mappings (Chap. 17) starting in 1770. His main influence on the development of mathematics and mathematical physics resulted from his textbooks, in particular from his famous *Introductio in analysin infinitorum* (1748), in which he also introduced many of the modern notations (for trigonometric functions, etc.). Euler was the central figure of the mathematical activity of the 18th century. His Collected Works are still incomplete, although some seventy volumes have already been published.

Cauchy worked in Paris, except during 1830–1838, when he was in Turin and Prague. In his two fundamental works, *Cours d'Analyse* (1821) and *Résumé des leçons données à l'École royale polytechnique* (vol. 1, 1823), he introduced more rigorous methods in calculus, based on an exactly defined limit concept; this also includes his convergence principle (Sec. 15.1). Cauchy also was the first to give existence proofs in ODEs. He initiated complex analysis; we discuss his main contributions to this field in Secs. 13.4, 14.2–14.4, and 15.2. His famous integral theorem (Sec. 14.2) was published in 1825 and his paper on complex power series and their radius of convergence (Sec. 15.2), in 1831.

### SOLUTIONS TO PROBLEM SET 2.5, page 72

2.  $4m(m - 1) + 4m - 1 = 4(m - \frac{1}{2})(m + \frac{1}{2}) = 0$ ,  $c_1\sqrt{x} + c_2/\sqrt{x}$

4.  $(c_1 + c_2 \ln x)/x$

6.  $2[m(m - 1) + 2m + 2.5] = 2(m^2 + m + 2.5) = 2[(m + \frac{1}{2})^2 + 1.5^2] = 0$ . The roots are  $-0.5 \pm 1.5i$ . Hence the corresponding real general solution is

$$y = x^{-0.5}[A \cos(1.5 \ln |x|) + B \sin(1.5 \ln |x|)].$$

8.  $4(m(m - 1) + \frac{1}{4}) = 4(m - \frac{1}{2})^2 = 0$  has the double root  $m = \frac{1}{2}$ ; hence a general solution is

$$y = (c_1 + c_2 \ln |x|)\sqrt{x}.$$

10.  $10m(m - 1) + 6m + 0.5 = 10[m(m - 1) + 0.6m + 0.05] = 10[m^2 - 0.4m + 0.05] = 10[(m - 0.2)^2 + 0.1^2] = 0$ . Hence a real general solution is

$$y = x^{0.2}[A \cos(0.1 \ln |x|) + B \sin(0.1 \ln |x|)].$$

12. The auxiliary equation is

$$m(m - 1) + 3m + 1 = m^2 + 2m + 1 = (m + 1)^2 = 0.$$

It has the double root  $-1$ . Hence a general solution is

$$y = (c_1 + c_2 \ln |x|)/x.$$

The first initial condition gives  $y(1) = c_1 = 4$ . The derivative of  $y$  is

$$y' = c_2/x^2 + (c_1 + c_2 \ln |x|)/(-x^2).$$

Hence the second initial condition gives  $y'(1) = c_2 - c_1 = -2$ . Thus  $c_2 = 2$ . This gives the particular solution

$$y = (4 + 2 \ln |x|)/x.$$

Make sure to explain to the student why we cannot prescribe initial conditions at  $t = 0$ , where the coefficients of the ODE written in standard form (divide by  $x^2$ ) become infinite.

14. The auxiliary equation is

$$m(m - 1) - 2m + 2.25 = m^2 - 3m + 2.25 = (m - 1.5)^2 = 0,$$

so that a general solution is

$$y = (c_1 + c_2 \ln |x|)x^{1.5}.$$

The first initial condition gives  $y(1) = c_1 = 2.2$ . The derivative is

$$y' = (c_2/x)x^{1.5} + 1.5(c_1 + c_2 \ln |x|)x^{0.5}.$$

From this and the second initial condition we obtain

$$y'(1) = c_2 + 1.5c_1 = 2.5;$$

hence

$$c_2 = 2.5 - 1.5c_1 = -0.8.$$

**16. Team Project. (A)** The student should realize that the present steps are the same as in the general derivation of the method in Sec. 2.1. An advantage of such specific derivations may be that the student gets a somewhat better understanding of the method and feels more comfortable with it. Of course, once a general formula is available, there is no objection to applying it to specific cases, but often a direct derivation may be simpler. In that respect the present situation resembles, for instance, that of the integral solution formula for first-order linear ODEs in Sec. 1.5.

**(B)** The Euler–Cauchy equation to start from is

$$x^2y'' + (1 - 2m - s)xy' + m(m + s)y = 0$$

where  $m = (1 - a)/2$ , the exponent of the one solution we first have in the critical case. For  $s \rightarrow 0$  the ODE becomes

$$x^2y'' + (1 - 2m)xy' + m^2y = 0.$$

Here  $1 - 2m = 1 - (1 - a) = a$ , and  $m^2 = (1 - a)^2/4$ , so that this is the Euler–Cauchy equation in the critical case. Now the ODE is homogeneous and linear; hence another solution is

$$Y = (x^{m+s} - x^m)/s.$$

L'Hôpital's rule, applied to  $Y$  as a function of  $s$  (not  $x$ , because the limit process is with respect to  $s$ , not  $x$ ), gives

$$(x^{m+s} \ln |x|)/1 \rightarrow x^m \ln |x| \quad \text{as } s \rightarrow 0.$$

This is the expected result.

**(C)** This is less work than perhaps expected, an exercise in the technique of differentiation (also necessary in other cases). We have  $y = x^m \ln x$ , and with  $(\ln x)' = 1/x$  we get

$$y' = mx^{m-1} \ln |x| + x^{m-1}$$

$$y'' = m(m - 1)x^{m-2} \ln |x| + mx^{m-2} + (m - 1)x^{m-2}.$$

Since  $x^m = x^{(1-a)/2}$  is a solution, in the substitution into the ODE the  $\ln$ -terms drop out. Two terms from  $y''$  and one from  $y'$  remain and give

$$x^2(mx^{m-2} + (m - 1)x^{m-2}) + ax^m = x^m(2m - 1 + a) = 0$$

because  $2m = 1 - a$ .

**(D)**  $t = \ln x$ ,  $dt/dx = 1/x$ ,  $y' = \dot{y}t' = \dot{y}/x$ , where the dot denotes the derivative with respect to  $t$ . By another differentiation,

$$y'' = (\dot{y}/x)' = \ddot{y}/x^2 + \dot{y}/(-x^2).$$

Substitution of  $y'$  and  $y''$  into (1) gives the constant-coefficient ODE

$$\ddot{y} - \dot{y} + a\dot{y} + by = \ddot{y} + (a - 1)\dot{y} + by = 0.$$

The corresponding characteristic equation has the roots

$$\lambda = \frac{1}{2}(1 - a) \pm \sqrt{\frac{1}{4}(1 - a)^2 - b}.$$

With these  $\lambda$ , solutions are  $e^{\lambda t} = (e^t)^\lambda = (e^{\ln |x|})^\lambda = x^\lambda$ .

$$(E) te^{\lambda t} = (\ln |x|)e^{\lambda \ln |x|} = (\ln |x|)(e^{\ln |x|})^\lambda = x^\lambda \ln |x|.$$

### SECTION 2.6. Existence and Uniqueness of Solutions. Wronskian, page 73

**Purpose.** To explain the theory of existence of solutions of ODEs with variable coefficients in standard form (that is, with  $y''$  as the first term, not, say,  $f(x)y''$ )

$$y'' + p(x)y' + q(x)y = 0$$

and of their uniqueness if initial conditions

$$y(x_0) = K_0, \quad y'(x_0) = K_1$$

are imposed. Of course, no such theory was needed in the last sections on ODEs for which we were able to write all solutions explicitly.

#### Main Content

Continuity of coefficients suffices for existence and uniqueness.

Linear independence if and only if the Wronskian is not zero

A general solution exists and includes all solutions.

#### Comment on Wronskian

For  $n = 2$ , where linear independence and dependence can be seen immediately, the Wronskian serves primarily as a tool in our proofs; the practical value of the independence criterion will appear for higher  $n$  in Chap. 3.

#### Comment on General Solution

Theorem 4 shows that linear ODEs (actually, of any order) have no singular solutions. This also justifies the term “general solution,” on which we commented earlier. We did not pay much attention to singular solutions, which sometimes occur in geometry as envelopes of one-parameter families of straight lines or curves.

### SOLUTIONS TO PROBLEM SET 2.6, page 77

2.  $y'' + \pi^2 y = 0$ . Wronskian

$$W = \begin{vmatrix} \cos \pi x & \sin \pi x \\ -\pi \sin \pi x & \pi \cos \pi x \end{vmatrix} = \pi.$$

4. Auxiliary equation  $(m - 3)(m + 2) = m^2 - m - 6 = m(m - 1) - 6 = 0$ . Hence the ODE is  $x^2 y'' - 6y = 0$ . The Wronskian is

$$W = \begin{vmatrix} x^3 & x^{-2} \\ 3x^2 & -2x^{-3} \end{vmatrix} = -2 - 3 = -5.$$

6. Characteristic equation  $(\lambda - 3.4)(\lambda + 2.5) = \lambda^2 - 0.9\lambda - 8.5 = 0$ . Hence the ODE is  $y'' - 0.9y' - 8.5y = 0$ . Wronskian

$$W = \begin{vmatrix} e^{3.4x} & e^{-2.5x} \\ 3.4e^{3.4x} & -2.5e^{-2.5x} \end{vmatrix} = -5.9e^{0.9x}.$$

8. Characteristic equation  $(\lambda + 2)^2 = 0$ , ODE  $y'' + 4y' + 4y = 0$ , Wronskian

$$W = \begin{vmatrix} e^{-2x} & xe^{-2x} \\ -2e^{-2x} & (1 - 2x)e^{-2x} \end{vmatrix} = e^{-4x}.$$

10. Auxiliary equation  $(m + 3)^2 = m^2 + 6m + 9 = m(m - 1) + 7m + 9 = 0$ . Hence the ODE (an Euler–Cauchy equation) is

$$x^2y'' + 7xy' + 9y = 0.$$

The Wronskian is

$$W = \begin{vmatrix} x^{-3} & x^{-3} \ln |x| \\ -3x^{-4} & -3x^{-4} \ln |x| + x^{-4} \end{vmatrix} = x^{-7}.$$

12. The characteristic equation is

$$(\lambda + 2)^2 + \omega^2 = \lambda^2 + 4\lambda + 4 + \omega^2 = 0.$$

Hence the ODE is

$$y'' + 4y' + (4 + \omega^2)y = 0.$$

The Wronskian is

$$W = \begin{vmatrix} ec & es \\ e(-2c - \omega s) & e(-2s + \omega c) \end{vmatrix} = \omega e^{-4x}$$

where  $e = e^{-2x}$ ,  $c = \cos \omega x$ , and  $s = \sin \omega x$ .

14. The auxiliary equation is

$$(m + 1)^2 + 1 = m^2 + 2m + 2 = m(m - 1) + 3m + 2 = 0.$$

Hence the Euler–Cauchy equation is

$$x^2y'' + 3xy' + 2y = 0.$$

The Wronskian is

$$W = \begin{vmatrix} x^{-1}c & x^{-1}s \\ -x^{-2}c - x^{-1}sx^{-1} & -x^{-2}s + x^{-1}cx^{-1} \end{vmatrix} = x^{-3}$$

where  $x^{-1}$  in the second row results from the chain rule and  $(\ln |x|)' = 1/x$ . Here,  $c = \cos(\ln |x|)$ ,  $s = \sin(\ln |x|)$ .

16. The characteristic equation is

$$(\lambda + k)^2 + \pi^2 = 0.$$

This gives the ODE

$$y'' + 2ky' + (k^2 + \pi^2)y = 0.$$

The Wronskian is

$$W = \begin{vmatrix} ec & es \\ e(-kc - s\pi) & e(-ks + c\pi) \end{vmatrix} = \pi e^{-2kx}$$

where  $e = e^{-kx}$ ,  $c = \cos \pi x$ ,  $s = \sin \pi x$ .

18. **Team Project.** (A)  $c_1e^x + c_2e^{-x} = c_1^* \cosh x + c_2^* \sinh x$ . Expressing cosh and sinh in terms of exponential functions [see (17) in App. 3.1], we have

$$\frac{1}{2}(c_1^* + c_2^*)e^x + \frac{1}{2}(c_1^* - c_2^*)e^{-x};$$

hence  $c_1 = \frac{1}{2}(c_1^* + c_2^*)$ ,  $c_2 = \frac{1}{2}(c_1^* - c_2^*)$ . The student should become aware that for second-order ODEs there are several possibilities for choosing a basis and making up a general solution. For this reason we say “a general solution,” whereas for first-order ODEs we said “the general solution.”

(B) If two solutions are 0 at the same point  $x_0$ , their Wronskian is 0 at  $x_0$ , so that these solutions are linearly dependent by Theorem 2.

(C) The derivatives would be 0 at that point. Hence so would be their Wronskian  $W$ , implying linear dependence.

(D) By the quotient rule of differentiation and by the definition of the Wronskian,

$$(y_2/y_1)' = (y_2'y_1 - y_2y_1')/y_1^2 = W/y_1^2.$$

In Prob. 10 we have  $(y_2/y_1)'y_1^2 = (\ln|x|)'x^{-6} = x^{-7}$ .

$y_2/y_1$  is constant in the case of linear dependence; hence the derivative of this quotient is 0, whereas in the case of linear independence this is not the case. This makes it likely that such a formula should exist.

(E) The first two derivatives of  $y_1$  and  $y_2$  are continuous at  $x = 0$  (the only  $x$  at which something could happen). Hence these functions qualify as solutions of a second-order ODE.  $y_1$  and  $y_2$  are linearly dependent for  $x \geq 0$  as well as for  $x < 0$  because in each of these two intervals, one of the functions is identically 0. On  $-1 < x < 1$  they are linearly independent because  $c_1y_1 + c_2y_2 = 0$  gives  $c_1 = 0$  when  $x \geq 0$ , and  $c_2 = 0$  when  $x < 0$ . The Wronskian is

$$W = y_1y_2' - y_2y_1' = \begin{cases} 0 \cdot 3x^2 - x^3 \cdot 0 \\ x^3 \cdot 0 - 0 \cdot 3x^2 \end{cases} = 0 \quad \text{if } \begin{cases} x < 0 \\ x \geq 0 \end{cases}.$$

The Euler–Cauchy equation satisfied by these functions has the auxiliary equation

$$(m - 3)m = m(m - 1) - 2m = 0.$$

Hence the ODE is

$$xy'' - 2y' = 0.$$

Indeed,  $xy_1'' - 2y_1' = x \cdot 6x - 2 \cdot 3x^2 = 0$  if  $x \geq 0$ , and  $0 = 0$  for  $x < 0$ . Similarly for  $y_2$ . Now comes the point. In the present case the standard form, as we use it in all our present theorems, is

$$y'' - \frac{2}{x}y' = 0$$

and shows that  $p(x)$  is not continuous at 0, as required in Theorem 2. Thus there is no contradiction.

This illustrates why the continuity assumption for the two coefficients is quite important.

(F) According to the hint given in the enunciation, the first step is to write the ODE (1) for  $y_1$  and then again for  $y_2$ . That is,

$$y_1'' + py_1' + qy_1 = 0$$

$$y_2'' + py_2' + qy_2 = 0$$

where  $p$  and  $q$  are variable. The hint then suggests eliminating  $q$  from these two ODEs. Multiply the first equation by  $-y_2$ , the second by  $y_1$ , and add:

$$(y_1y_2'' - y_1'y_2) + p(y_1y_2' - y_1'y_2) = W' + pW = 0$$



where the expression for  $W'$  results from the fact that  $y_1'y_2'$  appears twice and drops out. Now solve this by separating variables or as a homogeneous linear ODE.

In Prob. 12 we have  $p = 4$ ; hence  $W = ce^{-4x}$  by integration from 0 to  $x$ , where  $c = y_1(0)y_2'(0) - y_2(0)y_1'(0) = 1 \cdot \omega - 0 \cdot (-2) = \omega$ .

## SECTION 2.7. Nonhomogeneous ODEs. page 78

**Purpose.** We show that for getting a general solution  $y$  of a nonhomogeneous linear ODE we must find a general solution  $y_h$  of the corresponding homogeneous ODE and then—this is our new task—any particular solution  $y_p$  of the nonhomogeneous ODE,

$$y = y_h + y_p.$$

### Main Content, Important Concepts

General solution, particular solution

Continuity of  $p, q, r$  suffices for existence and uniqueness.

A general solution exists and includes all solutions.

### Comment on Methods for Particular Solutions

The method of undetermined coefficients is simpler than that of variation of parameters (Sec. 2.10), as is mentioned in the text, and it is sufficient for many applications, of which Secs. 2.8 and 2.9 show standard examples.

### Comment on General Solution

Theorem 2 shows that the situation with respect to general solutions is practically the same for homogeneous and nonhomogeneous linear ODEs.

### Comment on Table 2.1

It is clear that the table could be extended by the inclusion of products of polynomials times cosine or sine and other cases of limited practical value. Also,  $\alpha = 0$  in the last pair of lines gives the previous two lines, which are listed separately because of their practical importance.

## SOLUTIONS TO PROBLEM SET 2.7, page 83

- $y = c_1e^{-1.5x} + c_2e^{-2.5x} - 2.72 \cos 5x + 2.56 \sin 5x$ . This is a typical solution of a forced oscillation problem in the overdamped case. The general solution of the homogeneous ODE dies out, practically after some short time (theoretically never), and the transient solution goes over into a harmonic oscillation whose frequency is equal to that of the driving force (or electromotive force).
- $y = A \cos 3x + B \sin 3x + \frac{1}{8} \cos x + \frac{1}{18}x \sin 3x$ . An important point is that the Modification Rule applies to the second term on the right. Hence the best way seems to split  $y_p$  additively,  $y_p = y_{p1} + y_{p2}$ , where

$$y_{p1} = K_1 \cos x + M_1 \sin x, \quad y_{p2} = K_2x \cos 3x + M_2x \sin 3x.$$

In the previous problem (Prob. 3) the situation is similar.

- $y = (c_1 + c_2x)e^{-2x} - \frac{1}{4}e^{-2x} \sin 2x$ . The characteristic equation of the homogeneous ODE has the double root  $-2$ . The function on the right is such that the Modification Rule does not apply.

8.  $-5$  is a double root.  $100 \sinh 5x = 50e^{5x} - 50e^{-5x}$ . Hence we may choose  $y_p = y_{p1} + y_{p2}$  with  $y_{p2} = Cx^2e^{-5x}$  according to the Modification Rule. Substitution gives  $y_{p1} = \frac{1}{2}e^{5x}$ ,  $y_{p2} = -25x^2e^{-5x}$ . *Answer:*

$$y = (c_1 + c_2x)e^{-5x} + \frac{1}{2}e^{5x} - 25x^2e^{-5x}.$$

10.  $y = e^{-2x}(A \cos 1.5x + B \sin 1.5x) + 0.5x^2 + 0.36x + 0.1096$ . The solution of the homogeneous ODE approaches 0, and the term in  $x^2$  becomes the dominant term.
12. Corresponding to the right side, write  $y_p = y_{p1} + y_{p2}$ . Find  $y_{p1} = 2x$  by inspection or as usual. Since  $\sin 3x$  is a solution of the homogeneous ODE, write by the Modification Rule for a simple root  $y_p = x(K \cos 3x + M \sin 3x)$ . *Answer:*  $y = A \cos 3x + B \sin 3x + 2x - 6x \cos 3x$ .
14.  $2x \sin x$  is not listed in the table because it is of minor practical importance. However, by looking at its derivatives, we see that

$$y_p = Kx \cos x + Mx \sin x + N \cos x + P \sin x$$

should be general enough. Indeed, by substitution and collecting cosine and sine terms separately we obtain

$$(1) \quad (2K + 2Mx + 2P + 2M) \cos x = 0$$

$$(2) \quad (-2Kx + 2M - 2N - 2K) \sin x = 2x \sin x.$$

In (1) we must have  $2Mx = 0$ ; hence  $M = 0$  and then  $P = -K$ . In (2) we must have  $-2Kx = 2x$ ; hence  $K = -1$ , so that  $P = 1$  and from (2), finally,  $-2N - 2K = 0$ , hence  $N = 1$ . *Answer:*

$$y = (c_1 + c_2x)e^{-x} + (1 - x) \cos x + \sin x.$$

16.  $y = y_h + y_p = (c_1 + c_2x)e^{1.5x} + 12x^2 + 20x + 16$ . From this and the initial conditions,

$$y = 4[(1 + x)e^{1.5x} + 3x^2 + 5x + 4].$$

18.  $y_h = c_1e^{2x} + c_2$ ,  $y_p = C_1xe^{2x} + C_2e^{-2x}$  by the Modification Rule for a simple root. *Answer:*

$$y = 2e^{2x} - 3 + 6xe^{2x} - e^{-2x}.$$

20. The Basic Rule and the Sum Rule are needed. We obtain

$$y_h = e^{-x}(A \cos 3x + B \sin 3x)$$

$$y = e^{-x} \cos 3x - 0.4 \cos x + 1.8 \sin x + 6 \cos 3x - \sin 3x.$$

22. **Team Project.** (b) Perhaps the simplest way is to take a specific ODE, e.g.,

$$x^2y'' + 6xy' + 6y = r(x)$$

and then experiment by taking various  $r(x)$  to find the form of choice functions. The simplest case is a single power of  $x$ . However, almost all the functions that work as  $r(x)$  in the case of an ODE with constant coefficients can also be used here.

## SECTION 2.8. Modeling: Forced Oscillations. Resonance, page 84

**Purpose.** To extend Sec. 2.4 from free to forced vibrations by adding an input (a driving force, here assumed to be sinusoidal). Mathematically, we go from a homogeneous to a nonhomogeneous ODE, which we solve by undetermined coefficients.

**New Features**

**Resonance** (11)  $y = At \sin \omega_0 t$  in the undamped case

Beats (12)  $y = B(\cos \omega t - \cos \omega_0 t)$  if input frequency is close to natural

Large amplitude if (15\*)  $\omega^2 = \omega_0^2 - c^2/(2m^2)$  (Fig. 56)

Phase lag between input and output

**SOLUTIONS TO PROBLEM SET 2.8, page 90**

2.  $y_p = -0.6 \cos 1.5t + 0.2 \sin 1.5t$ . Note that a general solution of the homogeneous ODE is  $y_h = e^{-t}(A \cos 1.5t + B \sin 1.5t)$ , and the student should perhaps be reminded that *this is not resonance*, of course.
4.  $y_p = 0.25 \cos t$ . Note that  $y_h = e^{-2t}(A \cos t + B \sin t)$ ; of course, *this is not resonance*. Furthermore, it is interesting that whereas a single term on the right will generate two terms in the solution, here we have—by chance—the converse.
6.  $y_p = \frac{1}{10} \cos t + \frac{1}{5} \sin t - \frac{1}{90} \cos 3t + \frac{1}{45} \sin 3t$
8.  $y_p = 2 \cos 4t + 1.5 \sin 4t$
10.  $y = (c_1 + c_2 t)e^{-2t} - 0.03 \cos 4t + 0.04 \sin 4t$
12.  $y = c_1 e^{-t} + c_2 e^{-4t} - 0.1 \cos 2t$ . Note that, ordinarily,  $y_p$  will consist of two terms if  $r(x)$  consists of a single trigonometric term.
14.  $y = e^{-t}(A \cos 2t + B \sin 2t) + 0.2 - 0.1 \cos t + 0.2 \sin t$
16.  $y = -\frac{1}{63} \cos 8t + \frac{1}{8} \sin 8t + \frac{1}{63} \cos t$ . From the graph one can see the effect of  $(\cos t)/63$ . There is no corresponding sine term because there is no damping and hence no phase shift.
18.  $y = (33 + 31t)e^{-t} - 37.5 \cos t + 6 \cos 2t + 4.5 \sin 2t - 1.5 \cos 3t - 2 \sin 3t$
20.  $y = 100 \cos 4.9t - 98 \cos 5t$
22. The form of solution curves varies continuously with  $c$ . Hence if you start from  $c = 0$  and let  $c$  increase, you will at first obtain curves similar to those in the case of  $c = 0$ . For instance, consider  $y'' + 0.01y' + 25y = 100 \cos 4.9t - 98 \cos 5t$ .
24. **CAS Experiment.** The choice of  $\omega$  needs experimentation, inspection of the curves obtained, and then changes on a trial-and-error basis. It is interesting to see how in the case of beats the period gets increasingly longer and the maximum amplitude gets increasingly larger as  $\omega/(2\pi)$  approaches the resonance frequency.
26. If  $0 \leq t \leq \pi$ , then a particular solution

$$y_p = K_0 + K_1 t + K_2 t^2$$

gives  $y_p'' = 2K_2$  and

$$y_p'' + y_p = K_0 + 2K_2 + K_1 t + K_2 t^2 = 1 - \frac{1}{\pi^2} t^2;$$

thus,

$$K_2 = -\frac{1}{\pi^2}, \quad K_1 = 0, \quad K_0 = 1 - 2K_2 = 1 + \frac{2}{\pi^2}.$$

Hence a general solution is

$$y = A \cos t + B \sin t + 1 + \frac{2}{\pi^2} - \frac{1}{\pi^2} t^2.$$

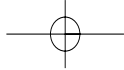

From this and the first initial condition,

$$y(0) = A + 1 + \frac{2}{\pi^2} = 0, \quad A = -\left(1 + \frac{2}{\pi^2}\right).$$

The derivative is

$$y' = -A \sin t + B \cos t - \frac{2}{\pi^2} t$$

and gives  $y'(0) = B = 0$ . Hence the solution is

$$(I) \quad y(t) = (1 + 2/\pi^2)(1 - \cos t) - t^2/\pi^2 \quad \text{if } 0 \leq t \leq \pi,$$

and if  $t > \pi$ , then

$$(II) \quad y = y_2 = A_2 \cos t + B_2 \sin t$$

with  $A_2$  and  $B_2$  to be determined from the continuity conditions

$$y(\pi) = y_2(\pi), \quad y'(\pi) = y_2'(\pi).$$

So we need from (I) and (II)

$$y(\pi) = 2(1 + 2/\pi^2) - 1 = 1 + 4/\pi^2 = y_2(\pi) = -A_2$$

and

$$y'(t) = (1 + 2/\pi^2) \sin t - 2t/\pi^2$$

and from this and (II),

$$y'(\pi) = -2/\pi = B_2 \cos \pi = -B_2.$$

This gives the solution

$$y = -(1 + 4/\pi^2) \cos t + (2/\pi) \sin t \quad \text{if } t > \pi.$$

Answer:

$$y = \begin{cases} (1 + 2/\pi^2)(1 - \cos t) - t^2/\pi^2 & \text{if } 0 \leq t \leq \pi \\ -(1 + 4/\pi^2) \cos t + (2/\pi) \sin t & \text{if } t > \pi \end{cases}$$

The function in the second line gives a harmonic oscillation because we disregarded damping.

## SECTION 2.9. Modeling: Electric Circuits, page 91

**Purpose.** To discuss the current in the *RLC*-circuit with sinusoidal input  $E_0 \sin \omega t$ .  
**ATTENTION!** The right side in (1) is  $E_0 \omega \cos \omega t$ , because of differentiation.

### Main Content

Modeling by Kirchhoff's law KVL

Electrical-mechanical strictly quantitative analogy (Table 2.2)

Transient tending to harmonic steady-state current

A popular complex method is discussed in Team Project 20.



**SOLUTIONS TO PROBLEM SET 2.9, page 97**

2. The occurring integral can be evaluated by integration by parts, as is shown (with other notations) in standard calculus texts. From (4) in Sec. 1.5 we obtain

$$\begin{aligned} I &= e^{-Rt/L} \left[ \frac{E_0}{L} \int e^{Rt/L} \sin \omega t \, dt + c \right] \\ &= ce^{-Rt/L} + \frac{E_0}{R^2 + \omega^2 L^2} (R \sin \omega t - \omega L \cos \omega t) \\ &= ce^{-Rt/L} + \frac{E_0}{\sqrt{R^2 + \omega^2 L^2}} \sin(\omega t - \delta), \quad \delta = \arctan \frac{\omega L}{R}. \end{aligned}$$

4. This is another special case of a circuit that leads to an ODE of first order,

$$RI' + I/C = E' = \omega E_0 \cos \omega t.$$

Integration by parts gives the solution

$$\begin{aligned} I(t) &= e^{-t/(RC)} \left[ \frac{\omega E_0}{R} \int e^{t/(RC)} \cos \omega t \, dt + c \right] \\ &= ce^{-t/(RC)} + \frac{\omega E_0 C}{1 + (\omega RC)^2} (\cos \omega t + \omega RC \sin \omega t) \\ &= ce^{-t/(RC)} + \frac{\omega E_0 C}{\sqrt{1 + (\omega RC)^2}} \sin(\omega t - \delta), \end{aligned}$$

where  $\tan \delta = -1/(\omega RC)$ . The first term decreases steadily as  $t$  increases, and the last term represents the steady-state current, which is sinusoidal. The graph of  $I(t)$  is similar to that in Fig. 62.

6.  $E = t^2$ ,  $E' = 2t$ ,  $0.5I'' + (10^4/8)I = 2t$ ,  $I'' + 2500I = 4t$ ,  $I(0) = 0$  is given.  $I'(0) = 0$  follows from

$$LI'(0) + Q(0)/C = E(0) = 0.$$

Answer:

$$I = 0.0016(t - 0.02 \sin 50t).$$

8. Write  $\lambda_1 = -\alpha + \beta$  and  $\lambda_2 = -\alpha - \beta$ , as in the text before Example 1. Here  $\alpha = R/(2L) > 0$ , and  $\beta$  can be real or imaginary. If  $\beta$  is real, then  $\beta \leq R/(2L)$  because  $R^2 - 4L/C \leq R^2$ . Hence  $\lambda_1 < 0$  (and  $\lambda_2 < 0$ , of course). If  $\beta$  is imaginary, then  $I_h(t)$  represents a damped oscillation, which certainly goes to zero as  $t \rightarrow \infty$ .
10.  $E' = 200 \cos 2t$ ,  $0.5I'' + 8I' + 10I = 200 \cos 2t$ , so that the steady-state solution is

$$I = 5 \cos 2t + 10 \sin 2t \text{ A.}$$

12. The ODE is

$$I'' + 2I' + 20I = \frac{157}{3} \cos 3t.$$

The steady-state solution is  $I_p = 2 \sin 3t + \frac{11}{3} \cos 3t$ .

Note that if you let  $C$  decrease, the sine term in the solution will become increasingly smaller, compared with the cosine term.

14. The ODE is

$$0.1I'' + 0.2I' + 0.5I = 377 \cos 0.5t.$$

Its characteristic equation is

$$0.1[(\lambda + 1)^2 + 4] = 0.$$

Hence a general solution of the homogeneous ODE is

$$e^{-t}(A \cos 2t + B \sin 2t).$$

The transient solution is

$$I = e^{-t}(A \cos 2t + B \sin 2t) + 760 \cos 0.5t + 160 \sin 0.5t.$$

16. The ODE is

$$0.1I'' + 4I' + 40I = 100 \cos 10t.$$

A general solution is

$$I = (c_1 + c_2t)e^{-20t} + 1.2 \cos 10t + 1.6 \sin 10t.$$

The initial conditions are  $I(0) = 0$ ,  $Q(0) = 0$ , which because of (1'), that is,

$$LI'(0) + RI(0) + \frac{Q(0)}{C} = E(0) = 0,$$

leads to  $I'(0) = 0$ . This gives

$$I(0) = c_1 + 1.2 = 0, \quad c_1 = -1.2$$

$$I'(0) = -20c_1 + c_2 + 16 = 0, \quad c_2 = -40.$$

Hence the answer is

$$I = -(1.2 + 40t)e^{-20t} + 1.2 \cos 10t + 1.6 \sin 10t.$$

18. The characteristic equation of the homogeneous ODE is

$$0.2(\lambda + 8)(\lambda + 10) = 0.$$

The initial conditions are  $I(0) = 0$  as given,  $I'(0) = E(0)/L = 164/0.2 = 820$  by formula (1') in the text and  $Q(0) = 0$ . Also,  $E' = -1640 \sin 10t$ . The ODE is

$$0.2I'' + 3.6I' + 16I = -1640 \sin 10t.$$

The answer is

$$I = 160 e^{-8t} - 205e^{-10t} + 45 \cos 10t + 5 \sin 10t.$$

20. **Team Project.** (a)  $\tilde{I}_p = Ke^{i\omega t}$ ,  $\tilde{I}'_p = i\omega Ke^{i\omega t}$ ,  $\tilde{I}''_p = -\omega^2 Ke^{i\omega t}$ . Substitution gives

$$\left(-\omega^2 L + i\omega R + \frac{1}{C}\right) Ke^{i\omega t} = E_0 \omega e^{i\omega t}.$$

Divide this by  $\omega e^{i\omega t}$  on both sides and solve the resulting equation algebraically for  $K$ , obtaining

$$(A) \quad K = \frac{E_0}{-\left(\omega L - \frac{1}{\omega C}\right) + iR} = \frac{E_0}{-S + iR}$$

where  $S$  is the reactance given by (3). To make the denominator real, multiply the numerator and the denominator of the last expression by  $-S - iR$ . This gives

$$K = \frac{-E_0(S + iR)}{S^2 + R^2}.$$

The real part of  $Ke^{i\omega t}$  is

$$\begin{aligned} (\operatorname{Re} K)(\operatorname{Re} e^{i\omega t}) - (\operatorname{Im} K)(\operatorname{Im} e^{i\omega t}) &= \frac{-E_0 S}{S^2 + R^2} \cos \omega t + \frac{E_0 R}{S^2 + R^2} \sin \omega t \\ &= \frac{-E_0}{S^2 + R^2} (S \cos \omega t - R \sin \omega t), \end{aligned}$$

in agreement with (2) and (4).

(b) See (A).

(c)  $R = 2 \Omega$ ,  $L = 1 \text{ H}$ ,  $C = \frac{1}{3} \text{ F}$ ,  $\omega = 1$ ,  $S = 1 - 3 = -2$ ,  $E_0 = 20$ .

From this and (4) it follows that  $a = 5$ ,  $b = 5$ ; hence

$$I_p = 5 \cos t + 5 \sin t.$$

For the complex method we obtain from (A)

$$K = \frac{20}{2 + 2i} = \frac{20(2 - 2i)}{8} = 5 - 5i.$$

Hence

$$\begin{aligned} I_p &= \operatorname{Re}(Ke^{it}) = \operatorname{Re}[(5 - 5i)(\cos t + i \sin t)] \\ &= 5 \cos t + 5 \sin t. \end{aligned}$$

## SECTION 2.10. Solution by Variation of Parameters, page 98

**Purpose.** To discuss the general method for particular solutions, which applies in any case but may often lead to difficulties in integration (which we by and large have avoided in our problems, as the subsequent solutions show).

### Comments

The ODE must be in *standard form*, with 1 as the coefficient of  $y''$ —students tend to forget that.

Here we do need the Wronskian, in contrast with Sec. 2.6 where we could get away without it.

## SOLUTIONS TO PROBLEM SET 2.10, page 101

2.  $y_1 = e^{2x}$ ,  $y_2 = xe^{2x}$ ,  $W = e^{4x}$ ,  $y_h = (c_1 + c_2x)e^{2x}$ ,

$$y_p = -e^{2x} \int x^3 e^{-x} dx + xe^{2x} \int x^2 e^{-x} dx = (x^2 + 4x + 6)e^x.$$

4.  $y_h = (c_1 + c_2x)e^x$ ,  $y_p = e^x(A \cos x + B \sin x)$ ,  $A = 0$  from the cosine terms,  $B = -1$  from the sine terms, so that

$$y_p = -e^x \sin x.$$

6. Division by  $x^2$  gives the standard form, and  $r = x^{-1} \ln |x|$ . A basis of solutions is  $y_1 = x$ ,  $y_2 = x \ln |x|$ ;  $W = x$ . The corresponding particular solution obtained from (2) is

$$\begin{aligned} y_p &= -x \int (x \ln |x|)(x^{-1} \ln |x|)x^{-1} dx + (x \ln |x|) \int x(x^{-1} \ln |x|)x^{-1} dx \\ &= -x \int (\ln |x|)^2 x^{-1} dx + x \ln |x| \int (\ln |x|)x^{-1} dx \\ &= x (\ln |x|)^3 / 6. \end{aligned}$$

8.  $y_h = (c_1 + c_2x)e^{2x}$ ,  $y_1 = e^{2x}$ ,  $y_2 = xe^{2x}$ ,  $W = e^{4x}$ . From (2) we thus obtain

$$y_p = -12e^{2x} \int x^{-3} dx + 12xe^{2x} \int x^{-4} dx = 2x^{-2}e^{2x}.$$

10. The right side suggests the following choice of a basis of solutions:

$$y_1 = \cosh x, \quad y_2 = \sinh x.$$

Then  $W = 1$ , and

$$\begin{aligned} y_p &= -\cosh x \int (\sinh x)/\cosh x dx + \sinh x \int (\cosh x)/\cosh x dx \\ &= -(\cosh x) \ln |\cosh x| + x \sinh x. \end{aligned}$$

12. Divide by  $x^2$  to get the standard form with  $r = 3x^{-3} + 3x^{-1}$ . A basis of solutions is  $y_1 = x^{1/2}$ ,  $y_2 = x^{-1/2}$ . The Wronskian is  $W = -x^{-1}$ . From this and (2) we obtain

$$\begin{aligned} y_p &= -x^{1/2} \int x^{-1/2}(3x^{-3} + 3x^{-1})(-x) dx \\ &\quad + x^{-1/2} \int x^{1/2}(3x^{-3} + 3x^{-1})(-x) dx \\ &= 4x^{-1} + 4x. \end{aligned}$$

14.  $y_1 = x^{-2}$ ,  $y_2 = x^2$ ,  $W = -4x^{-1}$ . Hence (2) gives

$$\begin{aligned} y_p &= -x^{-2} \int x^2 x^{-4}(x/4) dx + x^2 \int x^{-2} x^{-4}(x/4) dx \\ &= -\frac{1}{4}x^{-2} \ln |x| - \frac{1}{16}x^{-2}. \end{aligned}$$

16.  $y = ux^{-1/2}$  leads to  $u'' + u = 0$  by substitution. (This is a special case of the method of elimination of the first derivative, to be discussed in general in Prob. 29 of Problem Set 5.5 on the Bessel equation. The given homogeneous ODE is a special Bessel equation for which the Bessel functions reduce to elementary functions, namely, to cosines and sines times powers of  $x$ .) Hence a basis of solutions of the homogeneous ODE corresponding to the given ODE is

$$y_1 = x^{-1/2} \cos x, \quad y_2 = x^{-1/2} \sin x.$$

The Wronskian is  $W = x^{-1}$  and  $r = x^{-1/2} \cos x$ . Hence (2) gives

$$\begin{aligned} y_p &= -x^{-1/2} \cos x \int x^{-1/2} (\sin x) x^{-1/2} (\cos x) x dx \\ &\quad + x^{-1/2} \sin x \int x^{-1/2} (\cos x) x^{-1/2} (\cos x) x dx \\ &= -x^{-1/2} \cos x \int \sin x \cos x dx + x^{-1/2} \sin x \int \cos^2 x dx \\ &= \frac{1}{2}x^{1/2} \sin x. \end{aligned}$$

Note that here we have used that the ODE must be in standard form before we can apply (2). This is similar to the case of the Euler–Cauchy equations in this problem set.

18. **Team Project.** (a) Undetermined coefficients: Substitute

$$y_p = A \cos 5x + B \sin 5x$$

$$y_p' = -5A \sin 5x + 5B \cos 5x$$

$$y_p'' = -25A \cos 5x - 25B \sin 5x.$$



The cosine terms give  $-25A + 10B - 15A = 0$ ; hence  $B = 4A$ . The sine terms give  $-25B - 10A - 15B = -170A = 17$ ; hence  $A = -0.1$ ,  $B = -0.4$ .

For the method of variation of parameters we need

$$y_1 = e^{3x}, \quad y_2 = e^{-5x}; \quad \text{hence} \quad W = -8e^{-2x}.$$

From this and formula (2) we obtain integrals that are not too pleasant to evaluate, namely,

$$\begin{aligned} y_p &= -e^{3x} \int e^{-5x} \cdot 17 \sin 5x (-e^{2x}/8) dx \\ &\quad + e^{-5x} \int e^{3x} \cdot 17 \sin 5x (-e^{2x}/8) dx \\ &= -0.1 \cos 5x - 0.4 \sin 5x. \end{aligned}$$

(b) Apply variation of parameters to the first term,  $y_{p1} = \sec 3x$ , using  $y_1 = \cos 3x$ ,  $y_2 = \sin 3x$ , and  $W = 3$ . Formula (2) gives

$$\begin{aligned} y_{p1} &= -\cos 3x \int (\sin 3x \sec 3x)/3 dx \\ &\quad + \sin 3x \int (\cos 3x \sec 3x)/3 dx \\ &= \frac{1}{9} \cos 3x \ln |\cos 3x| + \frac{1}{3} x \sin 3x. \end{aligned}$$

For  $y_{p2}$  the method of undetermined coefficients gives

$$y_{p2} = -\frac{1}{6}x \cos 3x.$$

## SOLUTIONS TO CHAP. 2 REVIEW QUESTIONS AND PROBLEMS, page 102

10. Undetermined coefficients, where  $-3$  is a double root of the characteristic equation of the homogeneous ODE, so that the Modification Rule applies. The second term on the right,  $-27x^2$ , requires a quadratic polynomial. A general solution is

$$y = (c_1 + c_2x)e^{-3x} + \frac{1}{2}x^2e^{-3x} - 3x^2 + 4x - 2.$$

12.  $y' = z$ ,  $y'' = (dz/dy)z$  by the chain rule,  $yz dz/dy = 2z^2$ ,  $dz/z = 2 dy/y$ ,

$$\ln |z| = 2 \ln |y| + c^*, \quad z = c_1y^2 = y', \quad dy/y^2 = c_1 dx, \quad -1/y = c_1x + c_2;$$

hence

$$y = 1/(\tilde{c}_1x + \tilde{c}_2).$$

Also,  $y = 0$  is a solution.

14.  $y_1 = x^{-2}$ ,  $y_2 = x^{-3}$ ,  $W = -x^{-6}$ ,  $r = 1$  because to apply (2), one must first cast the given ODE into standard form. Then (2) gives

$$y_p = -x^{-2} \int x^{-3} \cdot 1(-x^6) dx + x^{-3} \int x^{-2} \cdot 1(-x^6) dx = x^2(\frac{1}{4} - \frac{1}{5}) = \frac{1}{20}x^2.$$

16.  $y_1 = e^{2x} \cos x$ ,  $y_2 = e^{2x} \sin x$ ,  $W = e^{4x}$ , so that (2) gives

$$\begin{aligned} y_p &= -e^{2x} \cos x \int e^{2x} \sin x e^{2x} \csc x e^{-4x} dx \\ &\quad + e^{2x} \sin x \int e^{2x} \cos x e^{2x} \csc x e^{-4x} dx \\ &= -e^{2x} (\cos x) x + e^{2x} (\sin x) \ln |\sin x|. \end{aligned}$$

18. This is an Euler–Cauchy equation, with the right-side 0 replaced with  $36x^5$ . The homogeneous ODE has the auxiliary equation

$$4m(m-1) - 24m + 49 = 4(m^2 - 7m + 3.5^2) = 4(m - 3.5)^2 = 0.$$

$m = 3.5$  is a double root, so that a general solution of the homogeneous ODE is

$$y_h = x^{3.5}(c_1 + c_2 \ln|x|).$$

We try

$$y_p = Cx^5. \quad \text{Then} \quad y_p' = 5Cx^4, \quad y_p'' = 20Cx^3.$$

Substitution gives

$$(4 \cdot 20 - 24 \cdot 5 + 49)Cx^5 = 9Cx^5 = 36x^4; \quad \text{hence} \quad C = 4.$$

This yields the general solution

$$y = x^{3.5}(c_1 + c_2 \ln|x|) + 4x^5$$

of the nonhomogeneous ODE.

Variation of parameters is slightly less convenient because of the integrations. For this we need  $y_1 = x^{3.5}$ ,  $y_2 = x^{3.5} \ln|x|$ ,  $W = x^6$ . The ODE must be written in standard form (divide by  $4x^2$ ), so that  $r = 9x^3$ . With these functions, equation (2) yields

$$\begin{aligned} y_p &= -x^{3.5} \int x^{3.5} \ln|x| \cdot 9x^3/x^6 dx \\ &\quad + x^{3.5} \ln|x| \int x^{3.5} \cdot 9x^3/x^6 dx \\ &= -9x^{3.5} \int x^{1/2} \ln|x| dx + 9x^{3.5} \ln|x| \int x^{1/2} dx \\ &= -x^5(6 \ln|x| - 4) + x^5 \cdot 6 \ln|x| = 4x^5. \end{aligned}$$

20. The characteristic equation is

$$\lambda^2 + 6\lambda + 18 = (\lambda + 3)^2 + 3^2 = 0.$$

Hence a general solution is

$$y = e^{-3x}(A \cos 3x + B \sin 3x)$$

and the initial values give  $A = 5$  and  $B = -2$ .

22. The auxiliary equation is

$$m(m-1) + 15m + 49 = (m+7)^2 = 0.$$

Hence a general solution is

$$y = (c_1 + c_2 \ln|x|)x^{-7}.$$

From the initial conditions,  $c_1 = 2$ ,  $c_2 = 3$ .

24. The characteristic equation is

$$\lambda^2 + \lambda + 2.5 = (\lambda + 0.5)^2 + 1.5^2 = 0.$$

Hence a general solution of the homogeneous ODE is

$$y_h = e^{-0.5x}(A \cos 1.5x + B \sin 1.5x).$$

A particular solution of the given ODE is  $6 \cos x + 4 \sin x$  (by undetermined coefficients). Hence

$$y = e^{-0.5x}(A \cos 1.5x + B \sin 1.5x) + 6 \cos x + 4 \sin x$$

and from the initial conditions,  $A = 2$ ,  $B = 1$ .

26. The ODE is

$$4y'' + 4y' + 17y = 202 \cos 3t.$$

Thus

$$y'' + y' + 4.25y = 50.5 \cos 3t.$$

The steady-state solution is obtained by the method of undetermined coefficients:

$$y_p = 4.8 \sin 3t - 7.6 \cos 3t.$$

28.  $y = e^{-0.5t}(A \cos 2t + B \sin 2t) - 7.6 \cos 3t + 4.8 \sin 3t$ . From this general solution and the initial conditions we obtain

$$y(0) = A - 7.6 = 10. \quad \text{Hence} \quad A = 17.6$$

and by differentiating and setting  $t = 0$

$$y'(0) = -0.5A + 2B + 3 \cdot 4.8 = 0.$$

Hence

$$B = 0.5(0.5A - 14.4) = -2.8.$$

30. The ODE is

$$2y'' + 6y' + 27y = 10 \cos \omega t.$$

The amplitude  $C^*(\omega)$  is given by (14) in Sec. 2.8. Its maximum is obtained by equating the derivative to zero; this gives the location  $\omega$  as solution of (15) in Sec. 2.8. In our case this is

$$36 = 2 \cdot 2^2(13.5 - \omega^2).$$

The solution is (15\*); in our case,

$$\omega_{\max}^2 = 13.5 - 4.5 = 9; \quad \text{thus} \quad \omega_{\max} = 3.$$

For this  $\omega = \omega_{\max}$  we obtain the maximum value of the amplitude from (16), Sec. 2.8; in our case,

$$C^*(\omega_{\max}) = \frac{2 \cdot 2 \cdot 10}{6\sqrt{4 \cdot 2^2 \cdot 13.5 - 36}} = \frac{\sqrt{20}}{9} = 0.496904.$$

By undetermined coefficients we obtain

$$y_p = \frac{2}{9} \cos 3t + \frac{4}{9} \sin 3t.$$

The amplitude is

$$C = \sqrt{a^2 + b^2} = \sqrt{(2/9)^2 + (4/9)^2} = \sqrt{20}/9,$$

in agreement with our previous result.

32.  $0.1I'' + 20I' + 5000I = 110 \cdot 415 \cos 415t$ . The characteristic equation of the homogeneous ODE is

$$\lambda^2 + 200\lambda + 50000 = (\lambda + 100)^2 + 200^2 = 0.$$

Hence a general solution of the homogeneous ODE is

$$I_h = e^{-100t}(A \cos 200t + B \sin 200t).$$

The method of undetermined coefficients gives the following particular solution of the nonhomogeneous ODE:

$$I_p = 1.735825 \sin 415t - 2.556159 \cos 415t.$$

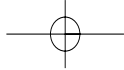

34. The real ODE is

$$0.4I'' + 40I' + 10000I = 220 \cdot 314 \cos 314t.$$

The complex ODE is

$$0.4\tilde{I}'' + 40\tilde{I}' + 10000\tilde{I} = 220 \cdot 314e^{314it}.$$

Substitution of

$$\tilde{I} = Ke^{314it}, \quad \tilde{I}' = 314iKe^{314it}, \quad \tilde{I}'' = -314^2Ke^{314it}$$

into the complex ODE gives

$$(0.4(-314^2) + 40 \cdot 314i + 10000)Ke^{314it} = 220 \cdot 314e^{314it}.$$

Solve this for  $K$ . Denote the expression  $(\cdot \cdot \cdot)$  on the left by  $M$ . Then

$$K = \frac{220 \cdot 314}{M} = -1.985219 - 0.847001i.$$

Furthermore, the desired particular solution  $I_p$  of the real ODE is the real part of  $Ke^{314it}$ , that is,

$$\begin{aligned} \operatorname{Re}(Ke^{314it}) &= \operatorname{Re} K \operatorname{Re}(e^{314it}) - \operatorname{Im} K \operatorname{Im}(e^{314it}) \\ &= -1.985219 \cos 314t - (-0.847001) \sin 314t. \end{aligned}$$

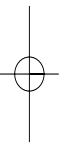

## CHAPTER 3 Higher Order Linear ODEs

This chapter is new. Its material is a rearranged and somewhat extended version of material previously contained in some of the sections of Chap 2. The rearrangement is such that the presentation parallels that in Chap. 2 for second-order ODEs, to facilitate comparisons.

### Root Finding

For higher order ODEs you may need Newton's method or some other method from Sec. 19.2 (which is independent of other sections in numerics) in work on a calculator or with your CAS (which may give you a root-finding method directly).

### Linear Algebra

The typical student may have taken an elementary linear algebra course simultaneously with a course on calculus and will know much more than is needed in Chaps. 2 and 3. Thus Chaps. 7 and 8 need not be taken before Chap. 3.

In particular, although the Wronskian becomes useful in Chap. 3 (whereas for  $n = 2$  one hardly needs it), a very modest knowledge of determinants will suffice. (For  $n = 2$  and 3, determinants are treated in a reference section, Sec. 7.6.)

### SECTION 3.1. Homogeneous Linear ODEs, page 105

**Purpose.** Extension of the basic concepts and theory in Secs. 2.1 and 2.6 to homogeneous linear ODEs of any order  $n$ . This shows that practically all the essential facts carry over without change. Linear independence, now more involved as for  $n = 2$ , causes the Wronskian to become indispensable (whereas for  $n = 2$  it played a marginal role).

#### Main Content, Important Concepts

Superposition principle for the homogeneous ODE (2)

General solution, basis, particular solution

General solution of (2) with continuous coefficients exists.

Existence and uniqueness of solution of initial value problem (2), (5)

Linear independence of solutions, Wronskian

General solution includes all solutions of (2).

#### Comment on Order of Material

In Chap. 2 we first gained practical experience and skill and presented the theory of the homogeneous linear ODE at the end of the discussion, in Sec. 2.6. In this chapter, with all the experience gained on second-order ODEs, it is more logical to present the whole theory at the beginning and the solution methods (for linear ODEs with constant coefficients) afterward. Similarly, the same logic applies to the nonhomogeneous linear ODE, for which Sec. 3.3 contains the theory as well as the solution methods.

### SOLUTIONS TO PROBLEM SET 3.1, page 111

- Problems 1–5 should give the student a first impression of the changes occurring in the transition from  $n = 2$  to general  $n$ .

8. Let  $y_1 = x + 1$ ,  $y_2 = x + 2$ ,  $y_3 = x$ . Then

$$y_2 - 2y_1 + y_3 = 0$$

shows linear dependence.

10. Linearly independent

12. Linear dependence, since one of the functions is the zero function

14.  $\cos 2x = \cos^2 x - \sin^2 x$ ; linearly dependent

16.  $(x - 1)^2 - (x + 1)^2 + 4x = 0$ ; linearly dependent

18. Linearly independent

20. **Team Project.** (a) (1) No. If  $y_1 \equiv 0$ , then (4) holds with any  $k_1 \neq 0$  and the other  $k_j$  all zero.

(2) Yes. If  $S$  were linearly dependent on  $I$ , then (4) would hold with a  $k_j \neq 0$  on  $I$ , hence also on  $J$ , contradicting the assumption.

(3) Not necessarily. For instance,  $x^2$  and  $x|x|$  are linearly dependent on the interval  $0 < x < 1$ , but linearly independent on  $-1 < x < 1$ .

(4) Not necessarily. See the answer to (3).

(5) Yes. See the answer to (2).

(6) Yes. By assumption,  $k_1 y_1 + \cdots + k_p y_p = 0$  with  $k_1, \dots, k_p$  not all zero (this refers to the functions in  $S$ ), and for  $T$  we can add the further functions with coefficients all zero; then the condition for linear dependence of  $T$  is satisfied.

(b) We can use the Wronskian for testing linear independence only if we know that the given functions are solutions of a homogeneous linear ODE with continuous coefficients. Other means of testing are the use of functional relations, e.g.,  $\ln x^2 = 2 \ln x$  or trigonometric identities, or the evaluation of the given functions at several values of  $x$ , to see whether we can discover proportionality.

### SECTION 3.2. Homogeneous Linear ODEs with Constant Coefficients, page 111

**Purpose.** Extension of the algebraic solution method for constant-coefficient ODEs from  $n = 2$  (Sec. 2.2) to any  $n$ , and discussion of the increased number of possible cases:

Real different roots

Complex simple roots

Real multiple roots

Complex multiple roots

Combinations of the preceding four basic cases

Explanation of these cases in terms of typical examples

#### Comment on Numerics

In practical cases, one may have to use Newton's method or another method for computing (approximate values of) roots in Sec. 19.2.

### SOLUTIONS TO PROBLEM SET 3.2, page 115

2. The form of the given functions shows that the characteristic equation has a triple root  $-2$ ; hence it is

$$(\lambda + 2)^3 = \lambda^3 + 6\lambda^2 + 12\lambda + 8 = 0.$$

Hence the ODE is

$$y''' + 6y'' + 12y' + 8y = 0.$$

4. The first two functions result from a factor  $\lambda^2 + 1$  of the characteristic equation, and the other two solutions show that the roots  $i$  and  $-i$  are double roots, so that the characteristic equation is

$$(\lambda^2 + 1)^2 = 0$$

and the ODE is

$$y^{iv} + 2y'' + y = 0.$$

6. The given functions show that the characteristic equation is

$$(\lambda + 2)(\lambda + 1)(\lambda - 1)(\lambda - 2)\lambda = \lambda^5 - 5\lambda^3 + 4\lambda = 0.$$

This gives the ODE

$$y^v - 5y''' + 4y' = 0.$$

8. The characteristic equation is quadratic in  $\mu = \lambda^2$ . The roots are

$$\mu = \frac{29}{2} \pm \sqrt{\frac{29^2}{4} - 100} = \frac{29}{2} \pm \frac{21}{2} = \begin{cases} 50/2 \\ 8/2. \end{cases}$$

The roots of this are  $\lambda = \pm 5$  and  $\pm 2$ . Hence a general solution is

$$y = c_1 e^{-2x} + c_2 e^{2x} + c_3 e^{-5x} + c_4 e^{5x}.$$

10. The characteristic equation is

$$16(\lambda^4 - \frac{1}{2}\lambda^2 + \frac{1}{16}) = 16(\lambda^2 - \frac{1}{4})^2 = 0.$$

It has the double roots  $\lambda = \pm \frac{1}{2}$ . This gives the general solution

$$y = (c_1 + c_2 x)e^{x/2} + (c_3 + c_4 x)e^{-x/2}.$$

12. The characteristic equation is

$$\lambda^4 + 3\lambda^2 - 4 = (\lambda^2 - 1)(\lambda^2 + 4) = 0.$$

Its roots are  $\pm 1$  and  $\pm 2i$ . Hence the corresponding real general solution is

$$y = c_1 e^x + c_2 e^{-x} + c_3 \cos 2x + c_4 \sin 2x.$$

14. The particular solution, solving the initial value problem, is

$$y = 4e^{-x} + 5e^{-x/2} \cos 3x.$$

From it, the general solution is obvious.

16.  $y = e^x(\frac{5}{16} \cos x - \frac{3}{16} \sin x) + e^{-x}(\frac{3}{16} \cos x - \frac{23}{16} \sin x)$

18.  $y = 10e^{-4x}(\cos 1.5x - \sin 1.5x) + 0.05e^{0.5x}$

20. **Project.** (a) Divide the characteristic equation by  $\lambda - \lambda_1$  if  $e^{\lambda_1 x}$  is known.

(b) The idea is the same as in Sec. 2.1.

(c) We first produce the standard form because this is the form under which the equation for  $z$  was derived. Division by  $x^3$  gives

$$y''' - \frac{3}{x} y'' + \left(\frac{6}{x^2} - 1\right) y' - \left(\frac{6}{x^3} - \frac{1}{x}\right) y = 0.$$

With  $y_1 = x$ ,  $y_1' = 1$ ,  $y_1'' = 0$ , and the coefficients  $p_1$  and  $p_2$  from the standard equation, we obtain

$$xz'' + \left[ 3 + \left(-\frac{3}{x}\right)x \right] z' + \left[ 2\left(-\frac{3}{x}\right) \cdot 1 + \left(\frac{6}{x^2} - 1\right)x \right] z = 0.$$

Simplification gives

$$xz'' + \left(-\frac{6}{x} + \frac{6}{x} - x\right)z = x(z'' - z) = 0.$$

Hence

$$z = c_1 e^x + \tilde{c}_2 e^{-x}.$$

By integration we get the *answer*

$$y_2 = x \int z \, dx = (c_1 e^x + c_2 e^{-x} + c_3)x.$$

### SECTION 3.3. Nonhomogeneous Linear ODEs, page 116

**Purpose.** To show that the transition from  $n = 2$  (Sec. 2.7) to general  $n$  introduces no new ideas but generalizes all results and practical aspects in a straightforward fashion; this refers to existence, uniqueness, and the need for a particular solution  $y_p$  to get a general solution in the form

$$y = y_h + y_p.$$

#### Comment on Elastic Beams

This is an important standard example of a fourth-order ODE that needs no lengthy preparations and explanations.

Vibrating beams follow in Problem Set 12.3. This leads to PDEs, since time  $t$  comes in as an additional variable.

#### Comment on Variation of Parameters

This method looks perhaps more complicated than it is; also the integrals may often be difficult to evaluate, and handling the higher order determinants that occur may require some more skill than the average student will have at this time. Thus it may be good to discuss this matter only rather briefly.

### SOLUTIONS TO PROBLEM SET 3.3, page 122

2. The characteristic equation is

$$\lambda^3 + 3\lambda^2 - 5\lambda - 39 = (\lambda^2 + 6\lambda + 13)(\lambda - 3) = [(\lambda + 3)^2 + 4](\lambda - 3) = 0.$$

Hence a general solution of the homogeneous ODE is

$$y_h = e^{-3x}(c_1 \cos 2x + c_2 \sin 2x) + c_3 e^{3x}.$$

Using the method of undetermined coefficients, substitute  $y_p = a \cos x + b \sin x$ , obtaining

$$y_p = -0.7 \cos x - 0.1 \sin x.$$

4. The characteristic equation is

$$\lambda^3 + 2\lambda^2 - 5\lambda - 6 = (\lambda + 1)(\lambda - 2)(\lambda + 3) = 0.$$



Hence a general solution of the homogeneous ODE is

$$y_h = c_1 e^{-x} + c_2 e^{2x} + c_3 e^{-3x}.$$

Since both terms on the right are solutions of the homogeneous ODE, the Modification Rule for undetermined coefficients applies. Substitution into the nonhomogeneous ODE gives the particular solution

$$y_p = (7 + 10x)e^{-3x} + \left(\frac{1}{2} - 3x\right)e^{-x}.$$

6. The homogeneous Euler–Cauchy equation can be solved as usual by substituting  $x^m$ . The auxiliary equation has the roots  $-2, 0, 1$ ; hence a general solution is

$$y_h = c_1 x^{-2} + c_2 + c_3 x.$$

This result can also be obtained by separating variables and integrating twice; that is,

$$y'''/y'' = -4/x, \quad \ln y'' = -4 \ln x + c, \quad y'' = c_1 x^{-4},$$

and so on. Variation of parameters gives

$$y_p = 8e^x(x^{-1} - x^{-2}).$$

8. The characteristic equation of the homogeneous ODE

$$\lambda^3 - 2\lambda^2 - 9\lambda + 18 = 0$$

has the roots  $-3, 2,$  and  $3$ . Hence a general solution of the homogeneous ODE is

$$y_h = c_1 e^{-3x} + c_2 e^{2x} + c_3 e^{3x}.$$

This also shows that the function on the right is a solution of the homogeneous ODE. Hence the Modification Rule applies, and the particular solution obtained is

$$y_p = -0.2xe^{2x}.$$

10. The characteristic equation of the homogeneous ODE is

$$\lambda^4 - 16 = (\lambda^2 - 4)(\lambda^2 + 4) = 0.$$

Hence a general solution of the homogeneous ODE is

$$y_h = c_1 e^{-2x} + c_2 e^{2x} + c_3 \cos 2x + c_4 \sin 2x.$$

A particular solution  $y_p$  of the nonhomogeneous ODE can be obtained by the method of undetermined coefficients; this  $y_p$  can be written in terms of exponential or hyperbolic functions:

$$\begin{aligned} y_p &= -1.5(e^{-2x} + e^{2x}) - 2x(e^{-2x} - e^{2x}) \\ &= -3 \cosh 2x + 4x \sinh 2x. \end{aligned}$$

Applying the initial conditions, we obtain the *answer*

$$y = 4e^{-2x} + 16 \sin 2x + y_p,$$

from which we cannot immediately recognize a basis of solutions. Of course, when  $\sin 2x$  occurs,  $\cos 2x$  must be in the basis. But  $e^{2x}$  remains hidden and cannot be seen from the answer.

12. The characteristic equation is quadratic in  $\lambda^2$ , the roots being  $-5, -1, 1, 5$ . The right side requires a quadratic polynomial whose coefficients can be determined by

substitution. Finally, the initial conditions are used to determine the four arbitrary constants in the general solution of the nonhomogeneous ODE thus obtained. The *answer* is

$$y = 5e^{-x} + e^{-5x} + 6.16 + 4x + 2x^2.$$

Again, two of four possible terms resulting from the homogeneous ODE are not visible in the answer. The student should recognize that all or some or none of the solutions of a basis of the homogeneous ODE may be present in the final answer; this will depend on the initial conditions, so the student should experiment a little with this problem to see what is going on.

14. The method of undetermined coefficients gives

$$y_p = 0.08 \cos x + 0.04 \sin x.$$

A basis of solutions of the homogeneous ODE is  $e^{-2x}$ ,  $e^{2x}$ ,  $e^{x/2}$ . From this and the initial conditions we obtain the *answer*

$$y = 0.11e^{-2x} - 0.15e^{2x} + 0.96e^{x/2} + y_p$$

in which all three basis functions occur.

16. The first equation has as a general solution

$$y = (c_1 + c_2x + c_3x^2)e^{4x} + \frac{8}{105}x^{7/2}e^{4x}.$$

Hence in cases such as this, one can try

$$y_p = x^{1/2}(a_0 + a_1x + a_2x^2 + a_3x^3)e^{4x}.$$

One can now modify the right side systematically and see how the solution changes.

The second ODE has as a general solution

$$y = c_1x^{-2} + c_2x + c_3x^3 - \frac{1}{216}x(18(\ln|x|)^2 + 6 \ln|x| + 7).$$

This shows that undetermined coefficients would not be suitable—the function on the right gives no clue of what  $y_p$  may look like.

Of course, the dependence on the left side also remains to be explored.

### SOLUTIONS TO CHAP. 3 REVIEW QUESTIONS AND PROBLEMS, page 122

6. The characteristic equation is

$$\lambda^3 + 6\lambda^2 + 18\lambda + 40 = [(\lambda + 1)^2 + 9](\lambda + 4) = 0.$$

Hence a general solution is

$$y = c_1e^{-4x} + e^{-x}(c_2 \cos 3x + c_3 \sin 3x).$$

8. The characteristic equation is quadratic in  $\lambda^2$ ; namely,

$$(\lambda^2 + 1)(\lambda^2 + 9) = 0.$$

Hence a general solution is

$$y = c_1 \cos x + c_2 \sin x + c_3 \cos 3x + c_4 \sin 3x.$$

10. The characteristic equation has the triple root  $-1$  because it is

$$(\lambda + 1)^3 = 0.$$

Hence a general solution of the homogeneous ODE is

$$y_h = (c_1 + c_2x + c_3x^2)e^{-x}.$$

The method of undetermined coefficients gives the particular solution

$$y_p = x^2 - 6x + 12.$$

**12.** The characteristic equation is

$$\lambda^2(\lambda + 2)(\lambda - 4) = 0.$$

Hence a general solution of the homogeneous ODE is

$$y_h = c_1 + c_2x + c_3e^{4x} + c_4e^{-2x}.$$

The method of undetermined coefficients gives the particular solution of the nonhomogeneous ODE in the form

$$y_p = 0.3 \cos 2x + 0.1 \sin 2x.$$

**14.** The auxiliary equation of the homogeneous ODE

$$x^3y''' + ax^2y'' + bxy' + cy = 0$$

is

$$m(m-1)(m-2) + am(m-1) + bm + c$$

$$= m^3 + (a-3)m^2 + (b-a+2)m + c = 0.$$

In our equation,  $a = -3$ ,  $b = 6$ , and  $c = -6$ . Accordingly, the auxiliary equation becomes

$$m^3 - 6m^2 + 11m - 6 = (m-1)(m-2)(m-3) = 0.$$

Hence a general solution of the homogeneous ODE is

$$y_h = c_1x + c_2x^2 + c_3x^3.$$

Variation of parameters gives the particular solution

$$y_p = -0.5x^{-2}.$$

**16.** The characteristic equation of the ODE is

$$\lambda^3 - 2\lambda^2 + 4\lambda - 8 = (\lambda - 2)(\lambda^2 + 4) = 0.$$

Hence a general solution is

$$y_h = c_1e^{2x} + c_2 \cos 2x + c_3 \sin 2x.$$

Using the initial conditions, we obtain the particular solution

$$y = 3e^{2x} - 4 \cos 2x + 12 \sin 2x.$$

**18.** The characteristic equation of the homogeneous ODE is

$$\lambda(\lambda^2 + 25) = 0.$$

Hence a general solution of the homogeneous ODE is

$$y_h = c_1 + c_2 \cos 5x + c_3 \sin 5x.$$

Using  $\cos^2 x = \frac{1}{2}(1 + \cos 2x)$ , we can apply the method of undetermined coefficients to obtain a particular solution of the nonhomogeneous ODE in the form

$$y_p = \frac{16}{25}x - \frac{2}{39} \sin 8x.$$

Finally, from the initial conditions we obtain the *answer*

$$y = -\frac{224}{4875} \sin 5x + y_p.$$

20. We can use the formula in the solution of Prob. 14,

$$m^3 + (a - 3)m^2 + (b - a + 2)m + c = 0,$$

where, in our present ODE,  $a = 5$ ,  $b = 2$ , and  $c = -2$ . Hence this formula becomes

$$m^3 + 2m^2 - m - 2 = (m - 1)(m + 1)(m + 2) = 0$$

and gives the basis of solutions  $x, x^{-1}, x^{-2}$ . Variation of parameters gives the particular solution of the nonhomogeneous ODE

$$y_p = 1.6x^{3/2}.$$

From this and the initial conditions we obtain the *answer*

$$y = 5x^{-2} + 4x + 1.6x^{3/2}.$$

## CHAPTER 4 Systems of ODEs. Phase Plane. Qualitative Methods

### Major Changes

This chapter was completely rewritten in the previous edition, on the basis of suggestions by instructors who have taught from it and my own recent experience. The main reason for rewriting was the increasing emphasis on **linear algebra** in our standard curricula, so that we can expect that students taking material from Chap. 4 have at least some working knowledge of  $2 \times 2$  matrices.

Accordingly, Chap. 4 makes modest use of  $2 \times 2$  matrices.  $n \times n$  matrices are mentioned only in passing and are immediately followed by illustrative examples of systems of two ODEs in two unknown functions, involving  $2 \times 2$  matrices only. Section 4.2 and the beginning of Sec. 4.3 are intended to give the student the impression that for first-order systems, one can develop a theory that is conceptually and structurally similar to that in Chap. 2 for a single ODE. Hence if the instructor feels that the class may be disturbed by  $n \times n$  matrices, omission of the latter and explanation of the material in terms of two ODEs in two unknown functions will entail no disadvantage and will leave no gaps of understanding or skill.

To be completely on the safe side, Sec. 4.0 is included for reference, so that the student will have no need to search through Chap. 7 or 8 for a concept or fact needed in Chap. 4.

Basic throughout Chap. 4 is the **eigenvalue problem** (for  $2 \times 2$  matrices), consisting first of the determination of the eigenvalues  $\lambda_1, \lambda_2$  (not necessarily numerically distinct) as solutions of the characteristic equation, that is, the quadratic equation

$$\begin{vmatrix} a_{11} - \lambda & a_{12} \\ a_{21} & a_{22} - \lambda \end{vmatrix} = (a_{11} - \lambda)(a_{22} - \lambda) - a_{12}a_{21} \\ = \lambda^2 - (a_{11} + a_{22})\lambda + a_{11}a_{22} - a_{12}a_{21} = 0,$$

and then an eigenvector corresponding to  $\lambda_1$  with components  $x_1, x_2$  from

$$(a_{11} - \lambda_1)x_1 + a_{12}x_2 = 0$$

and an eigenvector corresponding to  $\lambda_2$  from

$$(a_{11} - \lambda_2)x_1 + a_{12}x_2 = 0.$$

It may be useful to emphasize early that eigenvectors are determined only up to a nonzero factor and that in the present context, normalization (to obtain unit vectors) is hardly of any advantage.

If there are students in the class who have not seen eigenvalues before (although the elementary theory of these problems does occur in every up-to-date introductory text on beginning linear algebra), they should not have difficulties in readily grasping the meaning of these problems and their role in this chapter, simply because of the numerous examples and applications in Sec. 4.3 and in later sections.

Section 4.5 includes three famous applications, namely, the **pendulum** and **van der Pol equations** and the **Lotka–Volterra predator–prey population model**.

**SECTION 4.0. Basics of Matrices and Vectors, page 124**

**Purpose.** This section is for reference and review only, the material being restricted to what is actually needed in this chapter, to make it self-contained.

**Main Content**

Matrices, vectors  
Algebraic matrix operations  
Differentiation of vectors  
Eigenvalue problems for  $2 \times 2$  matrices

**Important Concepts and Facts**

Matrix, column vector and row vector, multiplication  
Linear independence  
Eigenvalue, eigenvector, characteristic equation

**Some Details on Content**

Most of the material is explained in terms of  $2 \times 2$  matrices, which play the major role in Chap. 4; indeed,  $n \times n$  matrices for general  $n$  occur only briefly in Sec. 4.2 and at the beginning in Sec. 4.3. Hence the demand of linear algebra on the student in Chap. 4 will be very modest, and Sec. 4.0 is written accordingly.

In particular, eigenvalue problems lead to quadratic equations only, so that nothing needs to be said about difficulties encountered with  $3 \times 3$  or larger matrices.

**Example 1.** Although the later sections include many eigenvalue problems, the complete solution of such a problem (the determination of the eigenvalues and corresponding eigenvectors) is given in Sec. 4.0.

**SECTION 4.1. Systems of ODEs as Models, page 130**

**Purpose.** In this section the student will gain a first impression of the importance of systems of ODEs in physics and engineering and will learn why they occur and why they lead to eigenvalue problems.

**Main Content**

Mixing problem  
Electrical network

**Conversion of single equations to systems (Theorem 1)**

The possibility of switching back and forth between systems and single ODEs is practically quite important because, depending on the situation, the system or the single ODE will be the better source for obtaining the information sought in a specific case.

**Background Material.** Secs. 2.4, 2.8.

**Short Courses.** Take a quick look at Sec. 4.1, skip Sec. 4.2 and the beginning of Sec. 4.3, and proceed directly to solution methods in terms of the examples in Sec. 4.3.

**Some Details on Content**

Example 1 extends the physical system in Sec. 1.3, consisting of a single tank, to a system of two tanks. The principle of modeling remains the same. The problem leads to a typical eigenvalue problem, and the solutions show typical exponential increases and decreases.

Example 2 leads to a nonhomogeneous first-order system (a kind of system to be considered in Sec. 4.6). The vector  $\mathbf{g}$  on the right in (5) causes the term  $+3$  in  $I_1$  but has no effect on  $I_2$ , which is interesting to observe. If time permits, one could add a little discussion of particular solutions corresponding to different initial conditions.

**Reduction of single equations to systems** (Theorem 1) should be emphasized. Example 3 illustrates it, and further applications follow in Sec. 4.5. It helps to create a “uniform” theory centered around first-order systems, along with the possibility of reducing higher order systems to first order.

### SOLUTIONS TO PROBLEM SET 4.1, page 135

2. The two balance equations (Inflow minus Outflow) change to

$$\begin{aligned}y_1' &= 0.004y_2 - 0.02y_1 \\y_2' &= 0.02y_1 - 0.004y_2\end{aligned}$$

where 0.004 appears because we divide through the content of the new tank, which is five times that of the old  $T_2$ . Ordering the system by interchanging the two terms on the right in the first equation and writing the system as a vector equation, we have

$$\mathbf{y}' = \mathbf{A}\mathbf{y}, \quad \text{where} \quad \mathbf{A} = \begin{bmatrix} -0.02 & 0.004 \\ 0.02 & -0.004 \end{bmatrix}.$$

The characteristic polynomial is  $\lambda^2 + 0.024\lambda = \lambda(\lambda + 0.024)$ . Hence the eigenvalues are 0 (as before) and  $-0.024$ . Eigenvectors can be obtained from the first component of the vector equation  $\mathbf{A}\mathbf{x} = \lambda\mathbf{x}$ ; that is,

$$-0.02x_1 + 0.004x_2 = \lambda x_1.$$

For  $\lambda = \lambda_1 = 0$  this is  $0.02x_1 = 0.004x_2$ , say,  $x_1 = 1$ ,  $x_2 = 5$ . For  $\lambda = \lambda_2 = -0.024$  this is  $-0.02x_1 + 0.004x_2 = -0.024x_1$ . This simplifies to

$$0.004x_1 + 0.004x_2 = 0. \quad \text{A solution is} \quad x_1 = 1, \quad x_2 = -1.$$

Hence a general solution of the system of ODEs is

$$\mathbf{y} = c_1 \begin{bmatrix} 1 \\ 5 \end{bmatrix} + c_2 \begin{bmatrix} 1 \\ -1 \end{bmatrix} e^{-0.024t}.$$

For  $t = 0$  this becomes, using the initial conditions  $y_1(0) = 0$ ,  $y_2(0) = 150$ ,

$$\mathbf{y}(0) = \begin{bmatrix} c_1 + c_2 \\ 5c_1 - c_2 \end{bmatrix} = \begin{bmatrix} 0 \\ 150 \end{bmatrix}. \quad \text{Solution:} \quad c_1 = 25, \quad c_2 = -25.$$

This gives the particular solution

$$\mathbf{y} = 25 \begin{bmatrix} 1 \\ 5 \end{bmatrix} - 25 \begin{bmatrix} 1 \\ -1 \end{bmatrix} e^{-0.024t}.$$

The situation described in the answer to Example 1 can no longer be achieved with the new tank, because the limits are 25 lb and 125 lb, as the particular solution shows.

4. With

$$a = \frac{\text{Flow rate}}{\text{Tank size}}$$

we can write the system that models the process in the following form:

$$\begin{aligned}y_1' &= ay_2 - ay_1 \\y_2' &= ay_1 - ay_2,\end{aligned}$$

ordered as needed for the proper vector form

$$\begin{aligned}y_1' &= -ay_1 + ay_2 \\y_2' &= ay_1 - ay_2.\end{aligned}$$

In vector form,

$$\mathbf{y}' = \mathbf{A}\mathbf{y}, \quad \text{where} \quad \mathbf{A} = \begin{bmatrix} -a & a \\ a & -a \end{bmatrix}.$$

The characteristic equation is

$$(\lambda + a)^2 - a^2 = \lambda^2 + 2a\lambda = 0.$$

Hence the eigenvalues are 0 and  $-2a$ . Corresponding eigenvectors are

$$\begin{bmatrix} 1 \\ 1 \end{bmatrix} \quad \text{and} \quad \begin{bmatrix} 1 \\ -1 \end{bmatrix}$$

respectively. The corresponding “general solution” is

$$\mathbf{y} = c_1 \begin{bmatrix} 1 \\ 1 \end{bmatrix} + c_2 \begin{bmatrix} 1 \\ -1 \end{bmatrix} e^{-2at}.$$

This result is interesting. It shows that the solution depends only on the ratio  $a$ , not on the tank size or the flow rate alone. Furthermore, the larger  $a$  is, the more rapidly  $y_1$  and  $y_2$  approach their limit.

The term “general solution” is in quotation marks because this term has not yet been defined *formally*, although it is clear what is meant.

6. The matrix of the system is

$$\mathbf{A} = \begin{bmatrix} -0.02 & 0.02 & 0 \\ 0.02 & -0.04 & 0.02 \\ 0 & 0.02 & -0.02 \end{bmatrix}.$$

The characteristic polynomial is

$$\lambda^3 + 0.08\lambda^2 + 0.0012\lambda = \lambda(\lambda + 0.02)(\lambda + 0.06).$$

This gives the eigenvalues and corresponding eigenvectors

$$\lambda_1 = 0, \quad \mathbf{x}^{(1)} = \begin{bmatrix} 1 \\ 1 \\ 1 \end{bmatrix}, \quad \lambda_2 = -0.02, \quad \mathbf{x}^{(2)} = \begin{bmatrix} 1 \\ 0 \\ -1 \end{bmatrix}, \quad \lambda_3 = -0.06, \quad \mathbf{x}^{(3)} = \begin{bmatrix} 1 \\ -2 \\ 1 \end{bmatrix}.$$



Hence a “general solution” is

$$\mathbf{y} = c_1 \begin{bmatrix} 1 \\ 1 \\ 1 \end{bmatrix} + c_2 \begin{bmatrix} 1 \\ 0 \\ -1 \end{bmatrix} e^{-0.02t} + c_3 \begin{bmatrix} 1 \\ -2 \\ 1 \end{bmatrix} e^{-0.06t}.$$

We use quotation marks since the concept of a general solution has not yet been defined *formally*, although it is clear what is meant.

8.  $R_1 = 8$  changes the first ODE to

$$I_1' = -8I_1 + 8I_2 + 12.$$

$R_1 = 8$  and  $R_2 = 12$  change the second ODE to

$$12I_2 + 8(I_2 - I_1) + 4 \int I_2 = 0.$$

By differentiation and simplification,

$$20I_2' - 8I_1' + 4I_2 = 0.$$

Divide by 20 and get rid of  $I_1'$  by using the first ODE,

$$I_2' - 0.4(-8I_1 + 8I_2 + 12) + 0.2I_2 = 0.$$

Simplify and order terms to get

$$I_2' = -3.2I_1 + 3.0I_2 + 4.8.$$

In vector form this gives

$$\mathbf{J}' = \mathbf{A}\mathbf{J} + \mathbf{g} = \begin{bmatrix} -8 & 8 \\ -3.2 & 3.0 \end{bmatrix} \begin{bmatrix} I_1 \\ I_2 \end{bmatrix} + \begin{bmatrix} 12 \\ 4.8 \end{bmatrix}.$$

The eigenvalues are  $\lambda_1 = -4.656$  and  $\lambda_2 = -0.3436$  (rounded values). Corresponding eigenvectors are

$$\mathbf{x}^{(1)} = \begin{bmatrix} 1 \\ 0.4180 \end{bmatrix} \quad \text{and} \quad \mathbf{x}^{(2)} = \begin{bmatrix} 1 \\ 0.9570 \end{bmatrix}.$$

From these we can construct a “general solution” of the homogeneous system. A “particular solution”  $\mathbf{J}_p$  of the nonhomogeneous system is suggested by the constant vector  $\mathbf{g}$ , namely, to try constant

$$\mathbf{J}_p = \begin{bmatrix} a_1 \\ a_2 \end{bmatrix}.$$

Then  $\mathbf{J}_p' = \mathbf{0}$ , and substitution into the formula for  $\mathbf{J}'$  gives

$$\mathbf{J}' = \mathbf{A}\mathbf{J}_p + \mathbf{g} = \mathbf{0},$$

in components,

$$-8a_1 + 8a_2 = -12$$

$$-3.2a_1 + 3.0a_2 = -4.8.$$

The solution is  $a_1 = 1.5$ ,  $a_2 = 0$ . Hence the *answer* is

$$\mathbf{J} = c_1 \begin{bmatrix} 1 \\ 0.4180 \end{bmatrix} e^{-4.656t} + c_2 \begin{bmatrix} 1 \\ 0.9570 \end{bmatrix} e^{-0.3436t} + \begin{bmatrix} 1.5 \\ 0 \end{bmatrix}.$$

10. The first ODE remains unchanged. The second is changed to

$$I_2' = 0.4I_1' - 0.54I_2.$$

Substitution of the first ODE into the new second one gives

$$I_2' = -1.6I_1 + 1.06I_2 + 4.8.$$

The matrix of the new system is

$$\mathbf{A} = \begin{bmatrix} -4 & 4 \\ -1.6 & 1.06 \end{bmatrix}.$$

Its eigenvalues are  $-1.5$  and  $-1.44$ . Corresponding eigenvectors are

$$\mathbf{x}^{(1)} = \begin{bmatrix} 1 \\ 0.625 \end{bmatrix} \quad \text{and} \quad \mathbf{x}^{(2)} = \begin{bmatrix} 1 \\ 0.64 \end{bmatrix}.$$

Hence the corresponding general solution of the homogeneous system is

$$\mathbf{J}_h = c_1 \mathbf{x}^{(1)} e^{-1.5t} + c_2 \mathbf{x}^{(2)} e^{-1.44t}.$$

A particular solution of the nonhomogeneous system is obtained as in Example 2 from

$$\begin{bmatrix} -4 & 4 \\ -1.6 & 1.06 \end{bmatrix} \begin{bmatrix} a_1 \\ a_2 \end{bmatrix} + \begin{bmatrix} 12 \\ 4.8 \end{bmatrix} = 0. \quad \text{Solution:} \quad \mathbf{a} = \begin{bmatrix} 3 \\ 0 \end{bmatrix}.$$

Hence a general solution of the nonhomogeneous system is

$$\mathbf{J} = c_1 \begin{bmatrix} 1 \\ 0.625 \end{bmatrix} e^{-1.5t} + c_2 \begin{bmatrix} 1 \\ 0.64 \end{bmatrix} e^{-1.44t} + \begin{bmatrix} 3 \\ 0 \end{bmatrix}.$$

From this and the initial conditions we have

$$\begin{aligned} c_1 + c_2 &= -3 \\ 0.625c_1 + 0.64c_2 &= 0. \end{aligned}$$

The solution is  $c_1 = -128$ ,  $c_2 = 125$ .

12. The system is

$$\begin{aligned} y_1' &= y_2 \\ y_2' &= 24y_1 - 2y_2. \end{aligned}$$

The matrix has the eigenvalues  $4$  and  $-6$ , as can be seen from the characteristic polynomial

$$\lambda^2 + 2\lambda - 24 = (\lambda - 4)(\lambda + 6).$$

Corresponding eigenvectors are  $[1 \ 4]^T$  and  $[1 \ -6]^T$ . A general solution is

$$y_1 = c_1 e^{4t} + c_2 e^{-6t} = y$$

and its derivative is

$$y_2 = 4c_1 e^{4t} - 6c_2 e^{-6t} = y'.$$

14.  $y_1' = y_2$ ,  $y_2' = -50y_1 - 15y_2$ . The matrix is

$$\mathbf{A} = \begin{bmatrix} 0 & 1 \\ -50 & -15 \end{bmatrix}.$$

The characteristic equation is  $\lambda^2 + 15\lambda + 50 = (\lambda + 5)(\lambda + 10) = 0$ . The roots are  $-5$  and  $-10$ . Eigenvectors are

$$\mathbf{x}^{(1)} = \begin{bmatrix} 1 \\ -5 \end{bmatrix} \quad \text{and} \quad \mathbf{x}^{(2)} = \begin{bmatrix} 1 \\ -10 \end{bmatrix}.$$

The corresponding general solution is

$$\mathbf{y} = c_1 \begin{bmatrix} 1 \\ -5 \end{bmatrix} e^{-5t} + c_2 \begin{bmatrix} 1 \\ -10 \end{bmatrix} e^{-10t}.$$

**16. Team Project. (a)** From Sec. 2.4 we know that the undamped motions of a mass on an elastic spring are governed by  $my'' + ky = 0$  or

$$my'' = -ky$$

where  $y = y(t)$  is the displacement of the mass. By the same arguments, for the two masses on the two springs in Fig. 80 we obtain the linear homogeneous system

$$(11) \quad \begin{aligned} m_1 y_1'' &= -k_1 y_1 + k_2 (y_2 - y_1) \\ m_2 y_2'' &= -k_2 (y_2 - y_1) \end{aligned}$$

for the unknown displacements  $y_1 = y_1(t)$  of the first mass  $m_1$  and  $y_2 = y_2(t)$  of the second mass  $m_2$ . The forces acting on the first mass give the first ODE, and the forces acting on the second mass give the second ODE. Now  $m_1 = m_2 = 1$ ,  $k_1 = 12$ , and  $k_2 = 8$  in Fig. 80 so that by ordering (11) we obtain

$$\begin{aligned} y_1'' &= -20y_1 + 8y_2 \\ y_2'' &= 8y_1 - 8y_2 \end{aligned}$$

or, written as a single vector equation,

$$\mathbf{y}'' = \begin{bmatrix} y_1'' \\ y_2'' \end{bmatrix} = \begin{bmatrix} -20 & 8 \\ 8 & -8 \end{bmatrix} \begin{bmatrix} y_1 \\ y_2 \end{bmatrix}.$$

**(b)** As for a single equation, we try an exponential function of  $t$ ,

$$\mathbf{y} = \mathbf{x}e^{\omega t}. \quad \text{Then} \quad \mathbf{y}'' = \omega^2 \mathbf{x}e^{\omega t} = \mathbf{A}\mathbf{x}e^{\omega t}.$$

Writing  $\omega^2 = \lambda$  and dividing by  $e^{\omega t}$ , we get

$$\mathbf{A}\mathbf{x} = \lambda\mathbf{x}.$$

Eigenvalues and eigenvectors are

$$\lambda_1 = -4, \quad \mathbf{x}^{(1)} = \begin{bmatrix} 1 \\ 2 \end{bmatrix} \quad \text{and} \quad \lambda_2 = -24, \quad \mathbf{x}^{(2)} = \begin{bmatrix} 2 \\ -1 \end{bmatrix}.$$

Since  $\omega = \sqrt{\lambda}$  and  $\sqrt{-4} = \pm 2i$  and  $\sqrt{-24} = \pm i\sqrt{24}$ , we get

$$\mathbf{y} = \mathbf{x}^{(1)}(c_1 e^{2it} + c_2 e^{-2it}) + \mathbf{x}^{(2)}(c_3 e^{i\sqrt{24}t} + c_4 e^{-i\sqrt{24}t})$$

or, by (10) in Sec. 2.2,

$$\mathbf{y} = a_1 \mathbf{x}^{(1)} \cos 2t + b_1 \mathbf{x}^{(1)} \sin 2t + a_2 \mathbf{x}^{(2)} \cos \sqrt{24}t + b_2 \mathbf{x}^{(2)} \sin \sqrt{24}t$$

where  $a_1 = c_1 + c_2$ ,  $b_1 = i(c_1 - c_2)$ ,  $a_2 = c_3 + c_4$ ,  $b_2 = i(c_3 - c_4)$ . These four arbitrary constants can be specified by four initial conditions. In components, this solution is

$$y_1 = a_1 \cos 2t + b_1 \sin 2t + 2a_2 \cos \sqrt{24}t + 2b_2 \sin \sqrt{24}t$$

$$y_2 = 2a_1 \cos 2t + 2b_1 \sin 2t - a_2 \cos \sqrt{24}t - b_2 \sin \sqrt{24}t.$$

(c) The first two terms in  $y_1$  and  $y_2$  give a slow harmonic motion, and the last two a fast harmonic motion. The slow motion occurs if at some instant both masses are moving downward or both upward. For instance, if  $a_1 = 1$  and all other arbitrary constants are zero, we get  $y_1 = \cos 2t$ ,  $y_2 = 2 \cos 2t$ ; this is an example of such a motion. The fast motion occurs if at each instant the two masses are moving in opposite directions, so that one of the two springs is extended, whereas the other is simultaneously compressed. For instance, if  $a_2 = 1$  and all other constants are zero, we have  $y_1 = 2 \cos \sqrt{24}t$ ,  $y_2 = -\cos \sqrt{24}t$ ; this is a fast motion of the indicated type. Depending on the initial conditions, one or the other motion will occur, or a superposition of both.

#### SECTION 4.2. Basic Theory of Systems of ODEs, page 136

**Purpose.** This survey of some basic concepts and facts on nonlinear and linear systems is intended to give the student an impression of the conceptual and structural similarity of the theory of systems to that of single ODEs.

##### Content, Important Concepts

- Standard form of first-order systems
- Form of corresponding initial value problems
- Existence of solutions
- Basis, general solution, Wronskian

**Background Material.** Sec. 2.6 contains the analogous theory for single equations. See also Sec. 1.7.

**Short Courses.** This section may be skipped, as mentioned before.

#### SECTION 4.3. Constant-Coefficient Systems. Phase Plane Method, page 139

**Purpose.** Typical examples show the student the rich variety of pattern of solution curves (trajectories) near critical points in the phase plane, along with the process of actually solving homogeneous linear systems. This will also prepare the student for a good understanding of the systematic discussion of critical points in the phase plane in Sec. 4.4.

##### Main Content

- Solution method for homogeneous linear systems
- Examples illustrating types of critical points
- Solution when no basis of eigenvectors is available (Example 6)

##### Important Concepts and Facts

- Trajectories as solution curves in the phase plane
- Phase plane as a means for the simultaneous (qualitative) discussion of a large number of solutions
- Basis of solutions obtained from basis of eigenvectors

**Background Material.** Short review of eigenvalue problems from Sec. 4.0, if needed.

**Short Courses.** Omit Example 6.

**Some Details on Content**

In addition to developing skill in solving homogeneous linear systems, the student is supposed to become aware that it is the kind of eigenvalues that determine the type of critical point. The examples show important cases. (A systematic discussion of *all* cases follows in the next section.)

**Example 1.** Two negative eigenvalues give a **node**.

**Example 2.** A real double eigenvalue gives a **node**.

**Example 3.** Real eigenvalues of opposite sign give a **saddle point**.

**Example 4.** Pure imaginary eigenvalues give a **center**, and working in complex is avoided by a standard trick, which can also be useful in other contexts.

**Example 5.** Genuinely complex eigenvalues give a **spiral point**. Some work in complex can be avoided, if desired, by differentiation and elimination. The first ODE is

$$(a) \quad y_2 = y_1' + y_1.$$

By differentiation and from the second ODE as well as from (a),

$$y_1'' = -y_1' + y_2' = -y_1' - y_1 - (y_1' + y_1) = -2y_1' - 2y_1.$$

Complex solutions  $e^{(-1 \pm i)t}$  give the real solution

$$y_1 = e^{-t}(A \cos t + B \sin t).$$

From this and (a) there follows the expression for  $y_2$  given in the text.

**Example 6** shows that the present method can be extended to include cases when **A** does not provide a basis of eigenvectors, but then becomes substantially more involved. In this way the student will recognize the importance of bases of eigenvectors, which also play a role in many other contexts.

**SOLUTIONS TO PROBLEM SET 4.3, page 146**

2. The eigenvalues are 5 and  $-5$ . Eigenvectors are  $[1 \ 1]^T$  and  $[1 \ -1]^T$ , respectively. Hence a general solution is

$$\begin{aligned} y_1 &= c_1 e^{5t} + c_2 e^{-5t} \\ y_2 &= c_1 e^{5t} - c_2 e^{-5t}. \end{aligned}$$

4. The eigenvalues are 13.5 and 4.5. Eigenvectors are  $[3 \ 1]^T$  and  $[3 \ -1]^T$ , respectively. Hence a general solution is

$$\begin{aligned} y_1 &= 3c_1 e^{13.5t} + 3c_2 e^{4.5t} \\ y_2 &= c_1 e^{13.5t} - c_2 e^{4.5t}. \end{aligned}$$

6. The eigenvalues are complex,  $2 + 2i$  and  $2 - 2i$ . Corresponding complex eigenvectors are  $[1 \ -i]^T$  and  $[1 \ i]^T$ , respectively. Hence a complex general solution is

$$\begin{aligned} y_1 &= c_1 e^{(2+2i)t} + c_2 e^{(2-2i)t} \\ y_2 &= -ic_1 e^{(2+2i)t} + ic_2 e^{(2-2i)t}. \end{aligned}$$

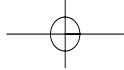

From this and the Euler formula we obtain a real general solution

$$\begin{aligned}y_1 &= e^{2t}[(c_1 + c_2) \cos 2t + i(c_1 - c_2) \sin 2t] \\ &= e^{2t}(A \cos 2t + B \sin 2t), \\ y_2 &= e^{2t}[(-ic_1 + ic_2) \cos 2t + i(-ic_1 - ic_2) \sin 2t] \\ &= e^{2t}(-B \cos 2t + A \sin 2t)\end{aligned}$$

where  $A = c_1 + c_2$  and  $B = i(c_1 - c_2)$ .

8. The eigenvalue of algebraic multiplicity 2 is 9. An eigenvector is  $[1 \ -1]^T$ . There is no basis of eigenvectors. A first solution is

$$\mathbf{y}^{(1)} = \begin{bmatrix} 1 \\ -1 \end{bmatrix} e^{9t}.$$

A second linearly independent solution is (see Example 6 in the text)

$$\mathbf{y}^{(2)} = \begin{bmatrix} 1 \\ -1 \end{bmatrix} t e^{9t} + \begin{bmatrix} u_1 \\ u_2 \end{bmatrix} e^{9t}$$

with  $[u_1 \ u_2]^T$  determined from

$$(\mathbf{A} - 9\mathbf{I})\mathbf{u} = \begin{bmatrix} -1 & -1 \\ 1 & 1 \end{bmatrix} \begin{bmatrix} u_1 \\ u_2 \end{bmatrix} = \begin{bmatrix} 1 \\ -1 \end{bmatrix}.$$

Thus  $u_1 + u_2 = -1$ . We can take  $u_1 = 0$ ,  $u_2 = -1$ . This gives the general solution

$$\mathbf{y} = c_1 \mathbf{y}^{(1)} + c_2 \mathbf{y}^{(2)} = (c_1 + c_2 t) \begin{bmatrix} 1 \\ -1 \end{bmatrix} e^{9t} + c_2 \begin{bmatrix} 0 \\ -1 \end{bmatrix} e^{9t}.$$

10. The eigenvalues are 3 and  $-1$ . Eigenvectors are  $[1 \ 2]^T$  and  $[1 \ -2]^T$ , respectively. Hence a general solution is

$$\mathbf{y} = c_1 \begin{bmatrix} 1 \\ 2 \end{bmatrix} e^{3t} + c_2 \begin{bmatrix} 1 \\ -2 \end{bmatrix} e^{-t}.$$

From this and the initial condition we obtain

$$\mathbf{y}(0) = c_1 \begin{bmatrix} 1 \\ 2 \end{bmatrix} + c_2 \begin{bmatrix} 1 \\ -2 \end{bmatrix} = \begin{bmatrix} 1 \\ 6 \end{bmatrix}.$$

Hence  $c_1 + c_2 = 1$ ,  $c_1 - c_2 = 3$ ,  $c_1 = 2$ ,  $c_2 = -1$ . The answer is

$$y_1 = 2e^{3t} - e^{-t}, \quad y_2 = 4e^{3t} + 2e^{-t}.$$

12. The eigenvalues are 5 and 1. Eigenvectors are  $[1 \ 1]^T$  and  $[1 \ -1]^T$ , respectively. A general solution is

$$\mathbf{y} = c_1 \begin{bmatrix} 1 \\ 1 \end{bmatrix} e^{5t} + c_2 \begin{bmatrix} 1 \\ -1 \end{bmatrix} e^t.$$

From this and the initial conditions we obtain  $c_1 + c_2 = 7$ ,  $c_1 - c_2 = 7$ ,  $c_1 = 7$ ,  $c_2 = 0$ . This gives the answer

$$y_1 = 7e^{5t}, \quad y_2 = 7e^{5t}.$$



14. The eigenvalues are complex,  $1 + i$  and  $1 - i$ . Eigenvectors are  $[2 - i \ 1]^T$  and  $[2 + i \ 1]^T$ , respectively. Using the Euler formula, we get from this the general solution

$$\mathbf{y} = e^t \left( c_1 \begin{bmatrix} 2 - i \\ 1 \end{bmatrix} (\cos t + i \sin t) + c_2 \begin{bmatrix} 2 + i \\ 1 \end{bmatrix} (\cos t - i \sin t) \right).$$

In terms of components this equals

$$y_1 = e^t [(c_1(2 - i) + c_2(2 + i)) \cos t + (ic_1(2 - i) - ic_2(2 + i)) \sin t]$$

$$y_2 = e^t [(c_1 + c_2) \cos t + (ic_1 - ic_2) \sin t].$$

Setting  $A = c_1 + c_2$  and  $B = i(c_1 - c_2)$ , we can write this in the form

$$y_1 = e^t [(2A - B) \cos t + (A + 2B) \sin t]$$

$$y_2 = e^t [A \cos t + B \sin t].$$

From this and the initial conditions we obtain  $y_1(0) = 2A - B = 7$ ,  $y_2(0) = A = 2$ ,  $B = -3$ . The answer is

$$y_1 = e^t (7 \cos t - 4 \sin t)$$

$$y_2 = e^t (2 \cos t - 3 \sin t).$$

16. The system is

$$(a) \quad y_1' = 8y_1 - y_2$$

$$(b) \quad y_2' = y_1 + 10y_2.$$

$10(a) + (b)$  gives  $10y_1' + y_2' = 81y_1$ ; hence

$$(c) \quad y_2' = -10y_1' + 81y_1.$$

Differentiating (a) and using (c) gives

$$\begin{aligned} 0 &= y_1'' - 8y_1' + y_2' \\ &= y_1'' - 8y_1' - 10y_1' + 81y_1 \\ &= y_1'' - 18y_1' + 81y_1. \end{aligned}$$

A general solution is

$$y_1 = (c_1 + c_2 t) e^{9t}.$$

From this and (a) we obtain

$$\begin{aligned} y_2 &= -y_1' + 8y_1 = [-c_2 - 9(c_1 + c_2 t) + 8(c_1 + c_2 t)] e^{9t} \\ &= (-c_2 - c_1 - c_2 t) e^{9t}, \end{aligned}$$

in agreement with the answer to Prob. 8.

18. The restriction of the inflow from outside to pure water is necessary to obtain a homogeneous system. The principle involved in setting up the model is

$$\text{Time rate of change} = \text{Inflow} - \text{Outflow}.$$

For Tank  $T_1$  this is (see Fig. 87)

$$y_1' = \left( 48 \cdot 0 + \frac{16}{400} y_2 \right) - \frac{64}{400} y_1.$$

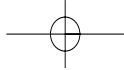

For Tank  $T_2$  it is

$$y_2' = \frac{64}{400} y_1 - \frac{16 + 48}{400} y_2.$$

Performing the divisions and ordering terms, we have

$$y_1' = -0.16y_1 + 0.04y_2$$

$$y_2' = 0.16y_1 - 0.16y_2.$$

The eigenvalues of the matrix of this system are  $-0.24$  and  $-0.08$ . Eigenvectors are  $[1 \ -2]^T$  and  $[1 \ 2]^T$ , respectively. The corresponding general solution is

$$\mathbf{y} = c_1 \begin{bmatrix} 1 \\ -2 \end{bmatrix} e^{-0.24t} + c_2 \begin{bmatrix} 1 \\ 2 \end{bmatrix} e^{-0.08t}.$$

The initial conditions are  $y_1(0) = 100$ ,  $y_2(0) = 40$ . This gives  $c_1 = 40$ ,  $c_2 = 60$ . In components the *answer* is

$$y_1 = 40e^{-0.24t} + 60e^{-0.08t}$$

$$y_2 = -80e^{-0.24t} + 120e^{-0.08t}.$$

Both functions approach zero as  $t \rightarrow \infty$ , a reasonable result, because pure water flows in and mixture flows out.

#### SECTION 4.4. Criteria for Critical Points. Stability, page 147

**Purpose.** Systematic discussion of critical points in the phase plane from the standpoints of both the geometrical shapes of trajectories and **stability**.

##### Main Content

Table 4.1 for the types of critical points

Table 4.2 for the stability behavior

Stability chart (Fig. 91), giving Tables 4.1 and 4.2 graphically

##### Important Concepts

Node, saddle point, center, spiral point

Stable and attractive, stable, unstable

**Background Material.** Sec. 2.4 (needed in Example 2).

**Short Courses.** Since all these types of critical points already occurred in the previous section, one may perhaps present just a short discussion of stability.

##### Some Details on Content

The types of critical points in Sec. 4.3 now recur, and the discussion shows that they exhaust all possibilities. With the examples of Sec. 4.3 fresh in mind, the student will acquire a deeper understanding by discussing the **stability chart** and by reconsidering those examples from the viewpoint of stability. This gives the instructor an opportunity to emphasize that the general importance of stability in engineering can hardly be overestimated.

**Example 2**, relating to the familiar free vibrations in Sec. 2.4, gives a good illustration of stability behavior, namely, depending on  $c$ , attractive stability, stability (and instability if one includes “negative damping,” with  $c < 0$ , as it will recur in the next section in connection with the famous van der Pol equation).



**SOLUTIONS TO PROBLEM SET 4.4, page 150**

2.  $p = 7, q = 12 > 0, \Delta = 49 - 48 > 0$ , unstable node,  $y_1 = c_1 e^{4t}, y_2 = c_2 e^{3t}$   
 4.  $p = -2, q = 5, \Delta = 4 - 20 < 0$ , stable and attractive spiral. The components of a general solution are

$$\begin{aligned} y_1 &= c_1 e^{(-1+2i)t} + c_2 e^{(-1-2i)t} \\ &= e^{-t}((c_1 + c_2) \cos 2t + i(c_1 - c_2) \sin 2t) \\ &= e^{-t}(A \cos 2t + B \sin 2t), \\ y_2 &= (-1 + 2i)c_1 e^{(-1+2i)t} + (-1 - 2i)c_2 e^{(-1-2i)t} \\ &= e^{-t}((-c_1 - c_2 + 2ic_1 - 2ic_2) \cos 2t + i(2ic_1 + 2ic_2 - c_1 + c_2) \sin 2t) \\ &= e^{-t}((-A + 2B) \cos 2t - (2A + B) \sin 2t) \end{aligned}$$

where  $A = c_1 + c_2$  and  $B = i(c_1 - c_2)$ .

6.  $p = -7, q = -78$ , saddle point, unstable,

$$\begin{aligned} y_1 &= c_1 e^{-13t} + c_2 e^{6t} \\ y_2 &= -1.4c_1 e^{-13t} + 0.5c_2 e^{6t} \end{aligned}$$

8.  $p = 0, q = 16$ , center, stable, eigenvalues  $4i, -4i$ , eigenvectors  $[1 \ -0.6 + 0.8i]^T$  and  $[1 \ -0.6 - 0.8i]^T$ , respectively, solution:

$$\begin{aligned} y_1 &= c_1 e^{4it} + c_2 e^{-4it} = A \cos 4t + B \sin 4t \\ y_2 &= (-0.6 + 0.8i)c_1 e^{4it} + (-0.6 - 0.8i)c_2 e^{-4it} \\ &= (-0.6 + 0.8i)c_1(\cos 4t + i \sin 4t) + (-0.6 - 0.8i)c_2(\cos 4t - i \sin 4t) \\ &= (-0.6(c_1 + c_2) + 0.8i(c_1 - c_2)) \cos 4t \\ &\quad + (-0.6i(c_1 - c_2) - 0.8(c_1 + c_2)) \sin 4t \\ &= (-0.6A + 0.8B) \cos 4t - (0.6B + 0.8A) \sin 4t \end{aligned}$$

where  $A = c_1 + c_2$  and  $B = i(c_1 - c_2)$ .

10.  $y_1 = y = c_1 e^{-5t} + c_2, y_2 = y' = -5c_1 e^{-5t} = -5(y_1 - c_2)$ , parallel straight lines  $5y_1 + y_2 = \text{const}$   
 12.  $y_1 = y = A \cos \frac{1}{4}t + B \sin \frac{1}{4}t, y_2 = y' = -\frac{1}{4}A \sin \frac{1}{4}t + \frac{1}{4}B \cos \frac{1}{4}t$ ; hence

$$y_1^2 + 16y_2^2 = (A^2 + B^2)(\cos^2 \frac{1}{4}t + \sin^2 \frac{1}{4}t) = \text{const}.$$

Ellipses.

14.  $y_1' = -dy_1/d\tau, y_2' = -dy_2/d\tau$ , reversal of the direction of motion. To get the usual form, we have to multiply the transformed system by  $-1$ . This amounts to multiplying the matrix by  $-1$ , changing  $p$  into  $-p$  (changing stability into instability and conversely when  $p \neq 0$ ) but leaving  $q$  and  $\Delta$  unchanged.  
 16. We have  $p = 0$  and  $q > 0$ . We get  $\tilde{p} = 2k \neq 0$  and

$$\tilde{q} = (a_{11} + k)(a_{22} + k) - a_{12}a_{21} = q + k(a_{11} + a_{22}) + k^2 = q + k^2 > 0$$

and

$$\tilde{\Delta} = \tilde{p}^2 - 4\tilde{q} = (2k)^2 - 4(q + k^2) = -4q < 0.$$

This gives a spiral point, which is stable and attractive if  $k < 0$  and unstable if  $k > 0$ .

**SECTION 4.5. Qualitative Methods for Nonlinear Systems, page 151**

**Purpose.** As a most important step, in this section we extend phase plane methods from linear to nonlinear systems and nonlinear ODEs.

**Main Content**

- Critical points of nonlinear systems
- Their discussion by linearization
- Transformation of single autonomous ODEs
- Applications of linearization and transformation techniques

**Important Concepts and Facts**

- Linearized system (3), condition for applicability
- Linearization of pendulum equations
- Self-sustained oscillations, van der Pol equation

**Short Courses.** Linearization at different critical points seems the main issue that the student is supposed to understand and handle practically. Examples 1 and 2 may help students to gain skill in that technique. The other material can be skipped without loss of continuity.

**Some Details on Content**

This section is very important, because from it the student should learn not only techniques (linearization, etc.) but also the fact that phase plane methods are particularly powerful and important in application to systems or single ODEs that cannot be solved explicitly. The student should also recognize that it is quite surprising how much information these methods can give. This is demonstrated by the **pendulum equation** (Examples 1 and 2) for a relatively simple system, and by the famous **van der Pol equation** for a single ODE, which has become a prototype for self-sustained oscillations of electrical systems of various kinds.

- We also discuss the famous **Lotka–Volterra predator–prey model**.
- For the **Rayleigh** and **Duffing equations**, see the problem set.

**SOLUTIONS TO PROBLEM SET 4.5, page 158****2. Writing the system in the form**

$$\begin{aligned}y_1' &= y_1(4 - y_1) \\ y_2' &= y_2\end{aligned}$$

we see that the critical points are  $(0, 0)$  and  $(4, 0)$ . For  $(0, 0)$  the linearized system is

$$\begin{aligned}y_1' &= 4y_1 \\ y_2' &= y_2.\end{aligned}$$

The matrix is

$$\begin{bmatrix} 4 & 0 \\ 0 & 1 \end{bmatrix}.$$

Hence  $p = 5$ ,  $q = 4$ ,  $\Delta = 25 - 16 = 9$ . This shows that the critical point at  $(0, 0)$  is an unstable node.

For  $(4, 0)$  the translation to the origin is

$$y_1 = 4 + \tilde{y}_1, \quad y_2 = \tilde{y}_2.$$

This gives the transformed system

$$\begin{aligned}\tilde{y}_1' &= (4 + \tilde{y}_1)(-\tilde{y}_1) \\ \tilde{y}_2' &= \tilde{y}_2\end{aligned}$$

and the corresponding linearized system

$$\begin{aligned}\tilde{y}_1' &= -4\tilde{y}_1 \\ \tilde{y}_2' &= \tilde{y}_2.\end{aligned}$$

Its matrix is

$$\begin{bmatrix} -4 & 0 \\ 0 & 1 \end{bmatrix}.$$

Hence  $\tilde{p} = -3$ ,  $\tilde{q} = -4$ . Thus the critical point at  $(4, 0)$  is a saddle point, which is always unstable.

#### 4. Writing the system as

$$\begin{aligned}\text{(a)} \quad y_1' &= -3y_1 + y_2(1 - y_2) \\ \text{(b)} \quad y_2' &= y_1 - 3y_2\end{aligned}$$

we see that a critical point is at  $(0, 0)$ . A second critical point is obtained by noting that the right side of (b) is zero when  $y_1 = 3y_2$ . Substitution into (a) gives  $-9y_2 + y_2(1 - y_2)$ , which is zero when  $y_2 = -8$ . Then  $y_1 = 3y_2 = -24$ . Hence a second critical point is at  $(-24, -8)$ .

At  $(0, 0)$  the linearized system is

$$\begin{aligned}y_1' &= -3y_1 + y_2 \\ y_2' &= y_1 - 3y_2.\end{aligned}$$

Its matrix is

$$\begin{bmatrix} -3 & 1 \\ 1 & -3 \end{bmatrix}.$$

Hence  $p = -6$ ,  $q = 8$ ,  $\Delta = 36 - 32 = 4 > 0$ . The critical point at  $(0, 0)$  is a stable and attractive node.

We turn to  $(-24, -8)$ . The translation to the origin is

$$y_1 = -24 + \tilde{y}_1, \quad y_2 = -8 + \tilde{y}_2.$$

The transformed system is

$$\begin{aligned}\tilde{y}_1' &= -3(-24 + \tilde{y}_1) + (-8 + \tilde{y}_2)(1 - (-8 + \tilde{y}_2)) \\ &= -3\tilde{y}_1 + 17\tilde{y}_2 - \tilde{y}_2^2 \\ \tilde{y}_2' &= -24 + \tilde{y}_1 + 24 - 3\tilde{y}_2 \\ &= \tilde{y}_1 - 3\tilde{y}_2.\end{aligned}$$

Its linearization is

$$\begin{aligned}\tilde{y}_1' &= -3\tilde{y}_1 + 17\tilde{y}_2 \\ \tilde{y}_2' &= \tilde{y}_1 - 3\tilde{y}_2.\end{aligned}$$

Its matrix is

$$\begin{bmatrix} -3 & 17 \\ 1 & -3 \end{bmatrix}.$$

Hence  $\tilde{q} = -8$ . The critical point at  $(-24, -8)$  is a saddle point.

6. The system may be written

$$\begin{aligned} y_1' &= y_2(1 - y_2) \\ y_2' &= y_1(1 - y_1). \end{aligned}$$

From this we see immediately that there are four critical points, at  $(0, 0)$ ,  $(0, 1)$ ,  $(1, 0)$ ,  $(1, 1)$ .

At  $(0, 0)$  the linearized system is

$$\begin{aligned} y_1' &= y_2 \\ y_2' &= y_1. \end{aligned}$$

The matrix is

$$\begin{bmatrix} 0 & 1 \\ 1 & 0 \end{bmatrix}.$$

Hence  $p = 0$ ,  $q = -1$ , so that we have a saddle point.

At  $(0, 1)$  the transformation is  $y_1 = \tilde{y}_1$ ,  $y_2 = 1 + \tilde{y}_2$ . This gives the transformed system

$$\begin{aligned} \tilde{y}_1' &= (1 + \tilde{y}_2)(-\tilde{y}_2) \\ \tilde{y}_2' &= \tilde{y}_1(1 - \tilde{y}_1). \end{aligned}$$

Linearization gives

$$\begin{aligned} \tilde{y}_1' &= -\tilde{y}_2 \\ \tilde{y}_2' &= \tilde{y}_1 \end{aligned} \quad \text{with matrix} \quad \begin{bmatrix} 0 & -1 \\ 1 & 0 \end{bmatrix}$$

for which  $\tilde{p} = 0$ ,  $\tilde{q} = 1$ ,  $\tilde{\Delta} = -4$ , and we have a center.

At  $(1, 0)$  the transformation is  $y_1 = 1 + \tilde{y}_1$ ,  $y_2 = \tilde{y}_2$ . The transformed system is

$$\begin{aligned} \tilde{y}_1' &= \tilde{y}_2(1 - \tilde{y}_2) \\ \tilde{y}_2' &= (1 + \tilde{y}_1)(-\tilde{y}_1). \end{aligned}$$

Its linearization is

$$\begin{aligned} \tilde{y}_1' &= \tilde{y}_2 \\ \tilde{y}_2' &= -\tilde{y}_1 \end{aligned} \quad \text{with matrix} \quad \begin{bmatrix} 0 & 1 \\ -1 & 0 \end{bmatrix}$$

for which  $\tilde{p} = 0$ ,  $\tilde{q} = 1$ ,  $\tilde{\Delta} = -4$ , so that we get another center.

At  $(1, 1)$  the transformation is

$$y_1 = 1 + \tilde{y}_1, \quad y_2 = 1 + \tilde{y}_2.$$

The transformed system is

$$\begin{aligned} \tilde{y}_1' &= (1 + \tilde{y}_2)(-\tilde{y}_2) \\ \tilde{y}_2' &= (1 + \tilde{y}_1)(-\tilde{y}_1). \end{aligned}$$

Linearization gives

$$\begin{aligned} \tilde{y}_1' &= -\tilde{y}_2 \\ \tilde{y}_2' &= -\tilde{y}_1 \end{aligned} \quad \text{with matrix} \quad \begin{bmatrix} 0 & -1 \\ -1 & 0 \end{bmatrix}$$

for which  $\tilde{p} = 0$ ,  $\tilde{q} = -1$ , and we have another saddle point.

8.  $y_1' = y_2$ ,  $y_2' = y_1(-9 - y_1)$ .  $(0, 0)$  is a critical point. The linearized system at  $(0, 0)$  is

$$\begin{aligned} y_1' &= y_2 \\ y_2' &= -9y_1 \end{aligned} \quad \text{with matrix} \quad \begin{bmatrix} 0 & 1 \\ -9 & 0 \end{bmatrix}$$

for which  $p = 0$  and  $q = 9 > 0$ , so that we have a center.

A second critical point is at  $(-9, 0)$ . The transformation is

$$y_1 = -9 + \tilde{y}_1, \quad y_2 = \tilde{y}_2.$$

This gives the transformed system

$$\begin{aligned} \tilde{y}_1' &= \tilde{y}_2 \\ \tilde{y}_2' &= (-9 + \tilde{y}_1)(-\tilde{y}_1). \end{aligned}$$

Its linearization is

$$\begin{aligned} \tilde{y}_1' &= \tilde{y}_2 \\ \tilde{y}_2' &= 9\tilde{y}_1 \end{aligned} \quad \text{with matrix} \quad \begin{bmatrix} 0 & 1 \\ 9 & 0 \end{bmatrix}$$

for which  $\tilde{q} = -9 < 0$ , so that we have a saddle point.

10. The system is

$$\begin{aligned} y_1' &= y_2 \\ y_2' &= -\sin y_1. \end{aligned}$$

The critical points occur at  $(\pm n\pi, 0)$ ,  $n = 0, 1, \dots$ , where the sine is zero and  $y_2 = 0$ .

At  $(0, 0)$  the linearized system is

$$\begin{aligned} y_1' &= y_2 \\ y_2' &= -y_1. \end{aligned}$$

Its matrix is

$$\begin{bmatrix} 0 & 1 \\ -1 & 0 \end{bmatrix}.$$

Hence  $p = 0$  and  $q = 1$ , so that we have a center. By periodicity, the points  $(\pm 2n\pi, 0)$  are centers.

We consider  $(\pi, 0)$ . The transformation is

$$y_1 = \pi + \tilde{y}_1, \quad y_2 = \tilde{y}_2.$$

This gives the transformed system

$$\begin{aligned} \tilde{y}_1' &= \tilde{y}_2 \\ \tilde{y}_2' &= -\sin(\pi + \tilde{y}_1) = \sin \tilde{y}_1. \end{aligned}$$

Linearization gives the system

$$\begin{aligned} \tilde{y}_1' &= \tilde{y}_2 \\ \tilde{y}_2' &= \tilde{y}_1. \end{aligned}$$

The matrix is

$$\begin{bmatrix} 0 & 1 \\ 1 & 0 \end{bmatrix}.$$

Hence  $\tilde{q} = -1$ . This is a saddle point. By periodicity the critical points at  $(\pi \pm 2n\pi, 0)$  are saddle points.

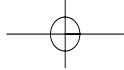

12. The system is

$$\begin{aligned}y_1' &= y_2 \\y_2' &= -y_1(2 - y_1) - y_2.\end{aligned}$$

The critical points are  $(0, 0)$  and  $(2, 0)$ . At  $(0, 0)$  the linearized system is

$$\begin{aligned}y_1' &= y_2 \\y_2' &= -2y_1 - y_2.\end{aligned}$$

Its matrix is

$$\begin{bmatrix} 0 & 1 \\ -2 & -1 \end{bmatrix}.$$

Hence  $p = -1$ ,  $q = 2$ ,  $\Delta = 1 - 8 < 0$ . This gives a stable and attractive spiral point.

At  $(2, 0)$  the transformation is

$$y_1 = 2 + \tilde{y}_1, \quad y_2 = \tilde{y}_2.$$

This gives the transformed system

$$\begin{aligned}\tilde{y}_1' &= \tilde{y}_2 \\ \tilde{y}_2' &= -(2 + \tilde{y}_1)(-\tilde{y}_1) - \tilde{y}_2.\end{aligned}$$

Its linearization is

$$\begin{aligned}\tilde{y}_1' &= \tilde{y}_2 \\ \tilde{y}_2' &= 2\tilde{y}_1 - \tilde{y}_2.\end{aligned}$$

Its matrix is

$$\begin{bmatrix} 0 & 1 \\ 2 & -1 \end{bmatrix}.$$

Hence  $\tilde{p} = -1$ ,  $\tilde{q} = -2 < 0$ . This gives a saddle point.

14. The system is

$$\begin{aligned}\text{(a)} \quad y_1' &= y_2 \\ \text{(b)} \quad y_2' &= 4y_1 - y_1^3.\end{aligned}$$

Multiply the left side of (a) by the right side of (b) and the right side of (a) by the left side of (b), obtaining

$$y_2 y_2' = (4y_1 - y_1^3) y_1'.$$

Integrate and multiply by 2:

$$y_2^2 = 4y_1^2 - \frac{1}{2}y_1^4 + c^*.$$

Setting  $c^* = c^2/2 - 8$ , write this as

$$y_2^2 = \frac{1}{2}(c + 4 - y_1^2)(c - 4 + y_1^2).$$

Some of these curves are shown in the figure.

16. The system is

$$\begin{aligned}y_1' &= y_2 \\ y_2' &= -2y_2 + 4y_1 - y_1^3 \\ &= -y_1(y_1 - 2)(y_1 + 2) - 2y_2.\end{aligned}$$

Hence the critical points are  $(0, 0)$ ,  $(2, 0)$ ,  $(-2, 0)$ .

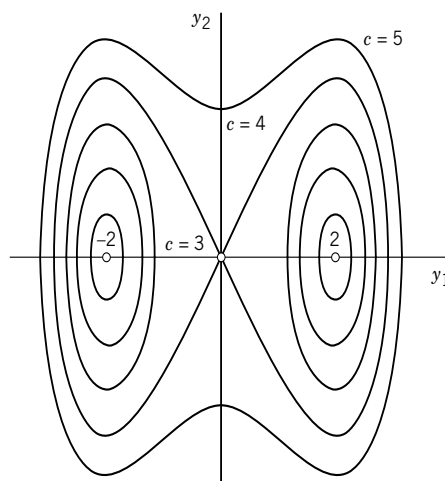

Section 4.5. Problem 14

At  $(0, 0)$  the linearized system is

$$\begin{aligned} y_1' &= y_2 \\ y_2' &= 4y_1 - 2y_2 \end{aligned} \quad \text{with matrix} \quad \begin{bmatrix} 0 & 1 \\ 4 & -2 \end{bmatrix}.$$

Hence  $p = -2$ ,  $q = -4 < 0$ , which gives a saddle point.

At  $(2, 0)$  the transformation is  $y_1 = 2 + \tilde{y}_1$ ,  $y_2 = \tilde{y}_2$ . This gives the system

$$\begin{aligned} \tilde{y}_1' &= \tilde{y}_2 \\ \tilde{y}_2' &= -(2 + \tilde{y}_1)\tilde{y}_1(\tilde{y}_1 + 4) - 2\tilde{y}_2 \end{aligned}$$

linearized

$$\begin{aligned} \tilde{y}_1' &= \tilde{y}_2 \\ \tilde{y}_2' &= -8\tilde{y}_1 - 2\tilde{y}_2 \end{aligned} \quad \text{with matrix} \quad \begin{bmatrix} 0 & 1 \\ -8 & -2 \end{bmatrix}.$$

Hence  $\tilde{p} = -2$ ,  $\tilde{q} = 8$ ,  $\tilde{\Delta} = 4 - 32 < 0$ . This gives a stable and attractive spiral point.

At  $(-2, 0)$  the transformation is  $y_1 = -2 + \tilde{\tilde{y}}_1$ ,  $y_2 = \tilde{\tilde{y}}_2$ . This gives the system

$$\begin{aligned} \tilde{\tilde{y}}_1' &= \tilde{\tilde{y}}_2 \\ \tilde{\tilde{y}}_2' &= -(-2 + \tilde{\tilde{y}}_1)(-4 + \tilde{\tilde{y}}_1)\tilde{\tilde{y}}_1 - 2\tilde{\tilde{y}}_2. \end{aligned}$$

Linearization gives

$$\begin{aligned} \tilde{\tilde{y}}_1' &= \tilde{\tilde{y}}_2 \\ \tilde{\tilde{y}}_2' &= -8\tilde{\tilde{y}}_1 - 2\tilde{\tilde{y}}_2 \end{aligned} \quad \text{with matrix} \quad \begin{bmatrix} 0 & 1 \\ -8 & -2 \end{bmatrix}$$

as before, so that we obtain another stable and attractive spiral point.

Note the similarity to the situation in the case of the undamped and damped pendulum.

- 18.** A limit cycle is approached by trajectories (from inside and outside). No such approach takes place for a closed trajectory.
- 20. Team Project. (a)** Unstable node if  $\mu \geq 2$ , unstable spiral point if  $2 > \mu > 0$ , center if  $\mu = 0$ , stable and attractive spiral point if  $0 > \mu > -2$ , stable and attractive node if  $\mu \leq -2$ .

(c) As a system we obtain

$$(A) \quad y_1' = y_2$$

$$(B) \quad y_2' = -(\omega_0^2 y_1 + \beta y_1^3).$$

The product of the left side of (A) and the right side of (B) equals the product of the right side of (A) and the left side of (B):

$$y_2' y_2 = -(\omega_0^2 y_1 + \beta y_1^3) y_1'.$$

Integration on both sides and multiplication by 2 gives

$$y_2^2 + \omega_0^2 y_1^2 + \frac{1}{2} \beta y_1^4 = \text{const.}$$

For positive  $\beta$  these curves are closed because then  $\beta y^3$  is a proper restoring term, adding to the restoring due to the  $y$ -term. If  $\beta$  is negative, the term  $\beta y^3$  has the opposite effect, and this explains why then some of the trajectories are no longer closed but extend to infinity in the phase plane.

For generalized van der Pol equations, see e.g., K. Klotter and E. Kreyszig, On a class of self-sustained oscillations. *J. Appl. Math.* **27**(1960), 568–574.

#### SECTION 4.6. Nonhomogeneous Linear Systems of ODEs, page 159

**Purpose.** We now turn from homogeneous linear systems considered so far to solution methods for nonhomogeneous systems.

##### Main Content

Method of undetermined coefficients

Modification for special right sides

Method of variation of parameters

**Short Courses.** Select just one of the preceding methods.

##### Some Details on Content

In addition to understanding the solution methods as such, the student should observe the conceptual and technical similarities to the handling of nonhomogeneous linear ODEs in Secs. 2.7–2.10 and understand the reason for this, namely, that systems can be converted to single equations and conversely. For instance, in connection with Example 1 in this section, one may point to the Modification Rule in Sec. 2.7, or, if time permits, establish an even more definite relation by differentiation and elimination of  $y_2$ ,

$$\begin{aligned} y_1'' &= -3y_1' + y_2' + 12e^{-2t} \\ &= -3y_1' + (y_1 - 3y_2 + 2e^{-2t})' + 12e^{-2t} \\ &= -3y_1' + y_1 - 3(y_1' + 3y_1 + 6e^{-2t}) + 14e^{-2t} \\ &= -6y_1' - 8y_1 - 4e^{-2t}, \end{aligned}$$

solving this for  $y_1$  and then getting  $y_2$  from the solution.

#### SOLUTIONS TO PROBLEM SET 4.6, page 162

2. We determine  $\mathbf{y}^{(h)}$ . The matrix is

$$\begin{bmatrix} 0 & 1 \\ 1 & 0 \end{bmatrix}.$$



It has the eigenvalues 1 and  $-1$  with eigenvectors  $[1 \ 1]^T$  and  $[1 \ -1]^T$ , respectively. Hence

$$\begin{aligned}y_1^{(h)} &= c_1 e^t + c_2 e^{-t} \\y_2^{(h)} &= c_1 e^t - c_2 e^{-t}.\end{aligned}$$

We determine  $\mathbf{y}^{(p)}$  by the method of undetermined coefficients, starting from

$$\begin{aligned}y_1^{(p)} &= a_1 t + b_1 \\y_2^{(p)} &= a_2 t + b_2.\end{aligned}$$

By differentiation,  $\mathbf{y}^{(p)'} = [a_1 \ a_2]^T$ . Substitution into

$$\mathbf{y}^{(p)'} = \mathbf{A}\mathbf{y}^{(p)} + \mathbf{g}$$

with  $\mathbf{g} = [t \ -3t]^T$  gives

$$\begin{aligned}a_1 &= a_2 t + b_2 + t \\a_2 &= a_1 t + b_1 - 3t.\end{aligned}$$

From the first equation,  $a_2 = -1$ ,  $b_2 = a_1$ . From the second equation,  $a_1 = 3$ ,  $b_1 = a_2$ . This gives the *answer*

$$\begin{aligned}y_1 &= c_1 e^t + c_2 e^{-t} + 3t - 1 \\y_2 &= c_1 e^t - c_2 e^{-t} - t + 3.\end{aligned}$$

4. The matrix of the system has the eigenvalues 2 and  $-2$ . Eigenvectors are  $[1 \ 1]^T$  and  $[1 \ -3]^T$ , respectively. Hence a general solution of the homogeneous system is

$$\mathbf{y}^{(h)} = c_1 \begin{bmatrix} 1 \\ 1 \end{bmatrix} e^{2t} + c_2 \begin{bmatrix} 1 \\ -3 \end{bmatrix} e^{-2t}.$$

We determine  $\mathbf{y}^{(p)}$  by the method of undetermined coefficients, starting from

$$\mathbf{y}^{(p)} = \begin{bmatrix} a_1 \cos t + b_1 \sin t \\ a_2 \cos t + b_2 \sin t \end{bmatrix}.$$

Substituting this and its derivative into the given nonhomogeneous system, we obtain, in terms of components,

$$\begin{aligned}-a_1 \sin t + b_1 \cos t &= (a_1 + a_2) \cos t + (b_1 + b_2) \sin t + 5 \cos t \\-a_2 \sin t + b_2 \cos t &= (3a_1 - a_2) \cos t + (3b_1 - b_2) \sin t - 5 \sin t.\end{aligned}$$

By equating the coefficients of the cosine and of the sine in the first of these two equations we obtain

$$b_1 = a_1 + a_2 + 5, \quad -a_1 = b_1 + b_2.$$

Similarly from the second equation,

$$b_2 = 3a_1 - a_2, \quad -a_2 = 3b_1 - b_2 - 5$$

The solution is  $a_1 = -1$ ,  $b_1 = 2$ ,  $a_2 = -2$ ,  $b_2 = -1$ . This gives the *answer*

$$\begin{aligned}y_1 &= c_1 e^{2t} + c_2 e^{-2t} - \cos t + 2 \sin t \\y_2 &= c_1 e^{2t} - 3c_2 e^{-2t} - 2 \cos t - \sin t.\end{aligned}$$

6.  $\mathbf{y}^{(h)}$  can be obtained from Example 5 in Sec. 4.3 in the form

$$\begin{aligned}\mathbf{y}^{(h)} &= c_1 \begin{bmatrix} 1 \\ i \end{bmatrix} e^{(-1+i)t} + c_2 \begin{bmatrix} 1 \\ -i \end{bmatrix} e^{(-1-i)t} \\ &= \begin{bmatrix} e^{-t}(A \cos t + B \sin t) \\ e^{-t}(B \cos t - A \sin t) \end{bmatrix}\end{aligned}$$

where  $A = c_1 + c_2$  and  $B = i(c_1 - c_2)$ .

$\mathbf{y}^{(p)}$  is obtained by the method of undetermined coefficients, starting from  $\mathbf{y}^{(p)} = [a_1 \ a_2]^T e^{-2t}$ . Differentiation and substitution into the given nonhomogeneous system gives, in components,

$$\begin{aligned}-2a_1 e^{-2t} &= (-a_1 + a_2)e^{-2t} + e^{-2t} \\ -2a_2 e^{-2t} &= (-a_1 - a_2)e^{-2t} - e^{-2t}.\end{aligned}$$

Dropping  $e^{-2t}$ , we have

$$\begin{aligned}-2a_1 &= -a_1 + a_2 + 1 \\ -2a_2 &= -a_1 - a_2 - 1.\end{aligned}$$

The solution is  $a_1 = -1$ ,  $a_2 = 0$ . We thus obtain the *answer*

$$\begin{aligned}y_1 &= e^{-t}(A \cos t + B \sin t) - e^{-2t} \\ y_2 &= e^{-t}(B \cos t - A \sin t).\end{aligned}$$

It is remarkable that  $y_2$  is the same as for the homogeneous system.

8. The matrix of the homogeneous system

$$\begin{bmatrix} 10 & -6 \\ 6 & -10 \end{bmatrix}$$

has the eigenvalues 8 and  $-8$  with eigenvectors  $[3 \ 1]^T$  and  $[1 \ 3]^T$ , respectively. Hence a general solution of the homogeneous system is

$$\mathbf{y}^{(h)} = c_1 \begin{bmatrix} 3 \\ 1 \end{bmatrix} e^{8t} + c_2 \begin{bmatrix} 1 \\ 3 \end{bmatrix} e^{-8t}.$$

We determine a particular solution  $\mathbf{y}^{(p)}$  of the nonhomogeneous system by the method of undetermined coefficients. We start from

$$\mathbf{y}^{(p)} = \begin{bmatrix} a_1 \\ a_2 \end{bmatrix} t^2 + \begin{bmatrix} b_1 \\ b_2 \end{bmatrix} t + \begin{bmatrix} k_1 \\ k_2 \end{bmatrix}.$$

Differentiation and substitution gives, in terms of components,

$$\begin{aligned}2a_1 t + b_1 &= (10a_1 - 6a_2)t^2 + (10b_1 - 6b_2)t + 10k_1 - 6k_2 - 10t^2 - 10t + 10 \\ 2a_2 t + b_2 &= (6a_1 - 10a_2)t^2 + (6b_1 - 10b_2)t + 6k_1 - 10k_2 - 6t^2 - 20t + 4.\end{aligned}$$

By equating the sum of the coefficients of  $t^2$  in each equation to zero we get

$$\begin{aligned}10a_1 - 6a_2 - 10 &= 0 \\ 6a_1 - 10a_2 - 6 &= 0.\end{aligned}$$

The solution is  $a_1 = 1$ ,  $a_2 = 0$ . Similarly for the terms in  $t$  we obtain

$$2a_1 = 10b_1 - 6b_2 - 10$$

$$2a_2 = 6b_1 - 10b_2 - 20.$$

The solution is  $b_1 = 0$ ,  $b_2 = -2$ . Finally, for the constant terms we obtain

$$b_1 = 10k_1 - 6k_2 + 10$$

$$b_2 = 6k_1 - 10k_2 + 4.$$

The solution is  $k_1 = -1$ ,  $k_2 = 0$ . The answer is  $\mathbf{y} = \mathbf{y}^{(h)} + \mathbf{y}^{(p)}$  with  $\mathbf{y}^{(h)}$  given above and

$$\mathbf{y}^{(p)} = \begin{bmatrix} t^2 - 1 \\ -2t \end{bmatrix}.$$

**12.** The matrix of the homogeneous system

$$\begin{bmatrix} 0 & 4 \\ -1 & 0 \end{bmatrix}$$

has the eigenvalues  $2i$  and  $-2i$  and eigenvectors  $\begin{bmatrix} 2 \\ i \end{bmatrix}^T$  and  $\begin{bmatrix} 2 \\ -i \end{bmatrix}^T$ , respectively. Hence a complex general solution is

$$\mathbf{y}^{(h)} = c_1 \begin{bmatrix} 2 \\ i \end{bmatrix} e^{2it} + c_2 \begin{bmatrix} 2 \\ -i \end{bmatrix} e^{-2it}.$$

By Euler's formula this becomes, in components,

$$y_1^{(h)} = (2c_1 + 2c_2) \cos 2t + i(2c_1 - 2c_2) \sin 2t$$

$$y_2^{(h)} = (ic_1 - ic_2) \cos 2t + (-c_1 - c_2) \sin 2t.$$

Setting  $A = c_1 + c_2$  and  $B = i(c_1 - c_2)$ , we can write

$$y_1^{(h)} = 2A \cos 2t + 2B \sin 2t$$

$$y_2^{(h)} = B \cos 2t - A \sin 2t.$$

Before we can consider the initial conditions, we must determine a particular solution  $\mathbf{y}^{(p)}$  of the given system. We do this by the method of undetermined coefficients, setting

$$y_1^{(p)} = a_1 e^t + b_1 e^{-t}$$

$$y_2^{(p)} = a_2 e^t + b_2 e^{-t}.$$

Differentiation and substitution gives

$$a_1 e^t - b_1 e^{-t} = 4a_2 e^t + 4b_2 e^{-t} + 5e^t$$

$$a_2 e^t - b_2 e^{-t} = -a_1 e^t - b_1 e^{-t} - 20e^{-t}.$$

Equating the coefficients of  $e^t$  on both sides, we get

$$a_1 = 4a_2 + 5, \quad a_2 = -a_1, \quad \text{hence} \quad a_1 = 1, \quad a_2 = -1.$$

Equating the coefficients of  $e^{-t}$ , we similarly obtain

$$-b_1 = 4b_2, \quad -b_2 = -b_1 - 20, \quad \text{hence} \quad b_1 = -16, \quad b_2 = 4.$$

Hence a general solution of the given nonhomogeneous system is

$$\begin{aligned}y_1 &= 2A \cos 2t + 2B \sin 2t + e^t - 16e^{-t} \\y_2 &= B \cos 2t - A \sin 2t - e^t + 4e^{-t}.\end{aligned}$$

From this and the initial conditions we obtain

$$y_1(0) = 2A + 1 - 16 = 1, \quad y_2(0) = B - 1 + 4 = 0.$$

The solution is  $A = 8$ ,  $B = -3$ . This gives the *answer* (the solution of the initial value problem)

$$\begin{aligned}y_1 &= 16 \cos 2t - 6 \sin 2t + e^t - 16e^{-t} \\y_2 &= -3 \cos 2t - 8 \sin 2t - e^t + 4e^{-t}.\end{aligned}$$

**14.** The matrix of the homogeneous system

$$\begin{bmatrix} 3 & -4 \\ 1 & -2 \end{bmatrix}$$

has the eigenvalues  $-1$  and  $2$ , with eigenvectors  $[1 \ 1]^T$  and  $[4 \ 1]^T$ , respectively. Hence a general solution of the homogeneous system is

$$y^{(h)} = c_1 \begin{bmatrix} 1 \\ 1 \end{bmatrix} e^{-t} + c_2 \begin{bmatrix} 4 \\ 1 \end{bmatrix} e^{2t}.$$

We determine a particular solution  $y^{(p)}$  of the nonhomogeneous system by the method of undetermined coefficients, starting from

$$y^{(p)} = \begin{bmatrix} A_1 \\ A_2 \end{bmatrix} \cos t + \begin{bmatrix} B_1 \\ B_2 \end{bmatrix} \sin t.$$

Differentiation and substitution gives, in terms of components,

$$(1) -A_1 \sin t + B_1 \cos t = 3A_1 \cos t + 3B_1 \sin t - 4A_2 \cos t - 4B_2 \sin t + 20 \cos t$$

$$(2) -A_2 \sin t + B_2 \cos t = A_1 \cos t + B_1 \sin t - 2A_2 \cos t - 2B_2 \sin t.$$

The coefficients of the cosine terms in (1) give

$$B_1 = 3A_1 - 4A_2 + 20$$

and for the sine terms we get

$$-A_1 = 3B_1 - 4B_2.$$

The coefficients of the cosine terms in (2) give

$$B_2 = A_1 - 2A_2$$

and for the sine terms we get

$$-A_2 = B_1 - 2B_2.$$

Hence  $A_1 = -14$ ,  $A_2 = -6$ ,  $B_1 = 2$ ,  $B_2 = -2$ . Consequently, a general solution of the given system is, in terms of components,

$$\begin{aligned}y_1 &= c_1 e^{-t} + 4c_2 e^{2t} - 14 \cos t + 2 \sin t \\y_2 &= c_1 e^{-t} + c_2 e^{2t} - 6 \cos t - 2 \sin t.\end{aligned}$$

From this and the initial condition we obtain

$$y_1(0) = c_1 + 4c_2 - 14 = 0, \quad y_2(0) = c_1 + c_2 - 6 = 8.$$

Hence  $c_1 = 14$ ,  $c_2 = 0$ . This gives the *answer*

$$y_1 = 14e^{-t} - 14 \cos t + 2 \sin t$$

$$y_2 = 14e^{-t} - 6 \cos t - 2 \sin t.$$

16. The matrix of the homogeneous system

$$\begin{bmatrix} 4 & 8 \\ 6 & 2 \end{bmatrix}$$

has the eigenvalues 10 and  $-4$  with eigenvectors  $[4 \ 3]^T$  and  $[1 \ -1]^T$ , respectively. Hence a general solution of the homogeneous system is

$$\mathbf{y}^{(h)} = c_1 \begin{bmatrix} 4 \\ 3 \end{bmatrix} e^{10t} + c_2 \begin{bmatrix} 1 \\ -1 \end{bmatrix} e^{-4t}.$$

A particular solution of the nonhomogeneous system is obtained by the method of undetermined coefficients. We start from

$$\mathbf{y}^{(p)} = \begin{bmatrix} A_1 \\ A_2 \end{bmatrix} \cos t + \begin{bmatrix} B_1 \\ B_2 \end{bmatrix} \sin t.$$

Differentiation and substitution gives, in components and  $\sin t$  and  $\cos t$  abbreviated by  $s$  and  $c$ , respectively,

$$(1) \quad -A_1s + B_1c = 4A_1c + 4B_1s + 8A_2c + 8B_2s + 2c - 16s$$

$$(2) \quad -A_2s + B_2c = 6A_1c + 6B_1s + 2A_2c + 2B_2s + c - 14s.$$

Equating the coefficients of the cosine terms in (1), we obtain

$$B_1 = 4A_1 + 8A_2 + 2.$$

Similarly, for the sine terms,

$$-A_1 = 4B_1 + 8B_2 - 16.$$

From (2) we obtain the two equations

$$B_2 = 6A_1 + 2A_2 + 1$$

$$-A_2 = 6B_1 + 2B_2 - 14.$$

The solution is  $A_1 = A_2 = 0$ ,  $B_1 = 2$ ,  $B_2 = 1$ . Hence a general solution of the nonhomogeneous system is

$$y_1 = 4c_1e^{10t} + c_2e^{-4t} + 2 \sin t$$

$$y_2 = 3c_1e^{10t} - c_2e^{-4t} + \sin t.$$

From this and the initial conditions we obtain

$$y_1(0) = 4c_1 + c_2 = 15, \quad y_2(0) = 3c_1 - c_2 = 13.$$

Hence  $c_1 = 4$ ,  $c_2 = -1$ . This gives the *answer* (the solution of the initial value problem)

$$y_1 = 16e^{10t} - e^{-4t} + 2 \sin t$$

$$y_2 = 12e^{10t} + e^{-4t} + \sin t.$$

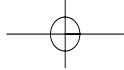

18. For the left circuit, Kirchhoff's voltage law gives

$$10I_1' + I_1 - I_2 = 10^4.$$

For the right circuit,

$$I_2 - I_1 + 0.8 \int I_2 dt = 0.$$

The first equation gives

$$I_1' = -0.1I_1 + 0.1I_2 + 1000.$$

By differentiation of the second equation and substitution of the first one (in the form just obtained) we obtain

$$\begin{aligned} I_2' &= I_1' - 0.8I_2 \\ &= -0.1I_1 + 0.1I_2 + 1000 - 0.8I_2. \end{aligned}$$

Hence the system of ODEs to be solved is

$$(A) \quad \begin{aligned} I_1' &= -0.1I_1 + 0.1I_2 + 1000 \\ I_2' &= -0.1I_1 - 0.7I_2 + 1000. \end{aligned}$$

The matrix of the homogeneous system is

$$\begin{bmatrix} -0.1 & 0.1 \\ -0.1 & -0.7 \end{bmatrix}.$$

It has the eigenvalues  $-0.4 \pm 0.2\sqrt{2}$ . An eigenvector for  $-0.4 + 0.2\sqrt{2} = -0.11716$  is

$$\mathbf{x}^{(1)} = [1 \quad -3 + 2\sqrt{2}]^T = [1 \quad -0.17157]^T.$$

An eigenvector for  $-0.4 - 0.2\sqrt{2} = -0.68284$  is

$$\mathbf{x}^{(2)} = [1 \quad -3 - 2\sqrt{2}]^T = [1 \quad -5.8284]^T.$$

A particular solution of the nonhomogeneous system is  $[10000 \quad 0]^T$ . We thus obtain as a general solution of the system (A)

$$\mathbf{I} = c_1 \mathbf{x}^{(1)} e^{-0.11716t} + c_2 \mathbf{x}^{(2)} e^{-0.68284t} + \begin{bmatrix} 10000 \\ 0 \end{bmatrix}$$

where  $\mathbf{x}^{(1)}$  and  $\mathbf{x}^{(2)}$  are those eigenvectors, and the initial conditions yield  $c_1 = -10303$  and  $c_2 = 303.30$ . With these values those conditions are satisfied, except for a roundoff error.

20. **Writing Project.** The problem set contains a number of special cases, and the student should compare them systematically with our earlier application of the method to single ODEs in Chap. 2 to fully understand how the method extends to systems of ODEs.

## SOLUTIONS TO CHAP. 4 REVIEW QUESTIONS AND PROBLEMS, page 163

12. The matrix

$$\begin{bmatrix} 9 & 0 \\ 0 & 1 \end{bmatrix}$$



has the eigenvalues 9 and 1 with eigenvectors  $[1 \ 0]^T$  and  $[0 \ 1]^T$ , respectively. Hence a general solution is

$$\mathbf{y} = c_1 \begin{bmatrix} 1 \\ 0 \end{bmatrix} e^{9t} + c_2 \begin{bmatrix} 0 \\ 1 \end{bmatrix} e^t.$$

Since  $p = 10$ ,  $q = 9$ ,  $\Delta = 100 - 36 > 0$ , the critical point is an unstable node.

14. The matrix

$$\begin{bmatrix} 3 & -3 \\ 3 & 3 \end{bmatrix}$$

has the eigenvalues  $3 + 3i$  and  $3 - 3i$  with eigenvectors  $[1 \ -i]^T$  and  $[1 \ i]^T$ , respectively. Hence a complex general solution is

$$\mathbf{y} = c_1 \begin{bmatrix} 1 \\ -i \end{bmatrix} e^{(3+3i)t} + c_2 \begin{bmatrix} 1 \\ i \end{bmatrix} e^{(3-3i)t}.$$

By Euler's formula, this becomes

$$\mathbf{y} = e^{3t} \left( c_1 \begin{bmatrix} 1 \\ -i \end{bmatrix} (\cos 3t + i \sin 3t) + c_2 \begin{bmatrix} 1 \\ i \end{bmatrix} (\cos 3t - i \sin 3t) \right).$$

Setting  $A = c_1 + c_2$ ,  $B = i(c_1 - c_2)$ , we can write this, in components,

$$\begin{aligned} y_1 &= e^{3t}(c_1 + c_2) \cos 3t + (ic_1 - ic_2) \sin 3t \\ &= e^{3t}(A \cos 3t + B \sin 3t) \\ y_2 &= e^{3t}((-ic_1 + ic_2) \cos 3t + (c_1 + c_2) \sin 3t) \\ &= e^{3t}(-B \cos 3t + A \sin 3t). \end{aligned}$$

Since  $p = 6$ ,  $q = 18$ ,  $\Delta = 36 - 72 < 0$ , the critical point is an unstable spiral point.

16. The matrix

$$\begin{bmatrix} -3 & -2 \\ -2 & -3 \end{bmatrix}$$

has the eigenvalues  $-5$  and  $-1$  with eigenvectors  $[1 \ 1]^T$  and  $[1 \ -1]^T$ , respectively. Hence a general solution is

$$\mathbf{y} = c_1 \begin{bmatrix} 1 \\ 1 \end{bmatrix} e^{-5t} + c_2 \begin{bmatrix} 1 \\ -1 \end{bmatrix} e^{-t}.$$

Since  $p = -6$ ,  $q = 5$ ,  $\Delta = 36 - 20 > 0$ , the critical point is a stable and attractive node.

18. The matrix

$$\begin{bmatrix} 3 & 5 \\ -5 & -3 \end{bmatrix}$$

has the eigenvalues  $4i$  and  $-4i$  with eigenvectors  $[1 \ -0.6 + 0.8i]^T$  and  $[1 \ -0.6 - 0.8i]^T$ , respectively. Hence a complex general solution is

$$\mathbf{y} = c_1 \begin{bmatrix} 1 \\ -0.6 + 0.8i \end{bmatrix} e^{4it} + c_2 \begin{bmatrix} 1 \\ -0.6 - 0.8i \end{bmatrix} e^{-4it}.$$

Setting  $A = c_1 + c_2$ ,  $B = i(c_1 - c_2)$  and using Euler's formula, we obtain, in terms of components,

$$\begin{aligned}y_1 &= (c_1 + c_2) \cos 4t + i(c_1 - c_2) \sin 4t \\ &= A \cos 4t + B \sin 4t \\ y_2 &= (-0.6c_1 + 0.8c_1i - 0.6c_2 - 0.8c_2i) \cos 4t \\ &\quad + (-i \cdot 0.6c_1 + i \cdot 0.6c_2 - 0.8c_1 - 0.8c_2) \sin 4t \\ &= (-0.6A + 0.8B) \cos 4t + (-0.6B - 0.8A) \sin 4t.\end{aligned}$$

Since  $p = 0$  and  $q = -9 + 25 > 0$ , the critical point is a center.

20. The matrix of the homogeneous system

$$\begin{bmatrix} 0 & 3 \\ 12 & 0 \end{bmatrix}$$

has the eigenvalues 6 and  $-6$  with eigenvectors  $[1 \ 2]^T$  and  $[1 \ -2]^T$ , respectively. A particular solution of the nonhomogeneous system is obtained by the method of undetermined coefficients. We set

$$y_1^{(p)} = a_1t + b_1, \quad y_2^{(p)} = a_2t + b_2.$$

Differentiation and substitution gives

$$a_1 = 3a_2t + 3b_2 + 6t, \quad a_2 = 12a_1t + 12b_1 + 1.$$

Hence  $a_1 = 0$ ,  $b_1 = -\frac{1}{4}$ ,  $a_2 = -2$ ,  $b_2 = 0$ . The answer is

$$\begin{aligned}y_1 &= c_1e^{6t} + c_2e^{-6t} - \frac{1}{4} \\ y_2 &= 2c_1e^{6t} - 2c_2e^{-6t} - 2t.\end{aligned}$$

22. The matrix

$$\begin{bmatrix} 1 & 1 \\ 4 & 1 \end{bmatrix}$$

has the eigenvalues 3 and  $-1$  with eigenvectors  $[1 \ 2]^T$  and  $[1 \ -2]^T$ , respectively. A particular solution of the nonhomogeneous system is obtained by the method of undetermined coefficients. We set

$$y_1^{(p)} = a_1 \cos t + b_1 \sin t, \quad y_2^{(p)} = a_2 \cos t + b_2 \sin t.$$

Differentiation and substitution gives the following two equations, where  $c = \cos t$  and  $s = \sin t$ ,

$$(1) \quad -a_1s + b_1c = a_1c + b_1s + a_2c + b_2s + s$$

$$(2) \quad -a_2s + b_2c = 4a_1c + 4b_1s + a_2c + b_2s.$$

From the cosine terms and the sine terms in (1) we obtain

$$b_1 = a_1 + a_2, \quad -a_1 = b_1 + b_2 + 1.$$

Similarly from (2),

$$b_2 = 4a_1 + a_2, \quad -a_2 = 4b_1 + b_2.$$

Hence  $a_1 = -0.3$ ,  $a_2 = 0.4$ ,  $b_1 = 0.1$ ,  $b_2 = -0.8$ . This gives the answer

$$\begin{aligned}y_1 &= c_1e^{3t} + c_2e^{-t} - 0.3 \cos t + 0.1 \sin t \\ y_2 &= 2c_1e^{3t} - 2c_2e^{-t} + 0.4 \cos t - 0.8 \sin t.\end{aligned}$$



24. The matrix of the homogeneous system

$$\begin{bmatrix} 1 & -2 \\ 3 & -4 \end{bmatrix}$$

has the eigenvalues  $-2$  and  $-1$  with eigenvectors  $[1 \ 1.5]^T$  and  $[1 \ 1]^T$ , respectively. A particular solution is obtained by the method of undetermined coefficients. The answer is

$$\begin{aligned} y_1 &= c_1 e^{-2t} + c_2 e^{-t} + 1.3 \cos t - 0.1 \sin t \\ y_2 &= 1.5c_1 e^{-2t} + c_2 e^{-t} + 0.7 \cos t + 0.1 \sin t. \end{aligned}$$

26. The balance equations are

$$\begin{aligned} y_1' &= -\frac{16}{200}y_1 + \frac{6}{100}y_2 \\ y_2' &= \frac{16}{200}y_1 - \frac{16}{100}y_2. \end{aligned}$$

Note that the denominators differ. Note further that the outflow to the right must be included in the balance equation for  $T_2$ . The matrix is

$$\begin{bmatrix} -0.08 & 0.06 \\ 0.08 & -0.16 \end{bmatrix}.$$

It has the eigenvalues  $-0.2$  and  $-0.04$  with eigenvectors  $[1 \ -2]^T$  and  $[1.5 \ 1]^T$ , respectively. The initial condition is  $y_1(0) = 160$ ,  $y_2(0) = 0$ . This gives the answer

$$\begin{aligned} y_1 &= 40e^{-0.2t} + 120e^{-0.04t} \\ y_2 &= -80e^{-0.2t} + 80e^{-0.04t}. \end{aligned}$$

28. From the figure we obtain by Kirchoff's voltage law for the left loop

$$0.4I_1' + 0.5(I_1 - I_2) + 0.7I_1 = 1000$$

and for the right loop

$$0.5I_2' + 0.5(I_2 - I_1) = 0.$$

Written in the usual form, we obtain

$$\begin{aligned} I_1' &= -3I_1 + 1.25I_2 + 2500 \\ I_2' &= I_1 - I_2. \end{aligned}$$

The matrix of the homogeneous system is

$$\begin{bmatrix} -3 & 1.25 \\ 1 & -1 \end{bmatrix}.$$

It has the eigenvalues  $-3.5$  and  $-0.5$  with eigenvectors  $[5 \ -2]^T$  and  $[1 \ 2]^T$ , respectively. From this and the initial conditions we obtain the solution

$$\begin{aligned} I_1 &= -\frac{12500}{21}e^{-3.5t} - \frac{2500}{3}e^{-0.5t} + \frac{10000}{7} \\ I_2 &= \frac{5000}{21}e^{-3.5t} - \frac{5000}{3}e^{-0.5t} + \frac{10000}{7}. \end{aligned}$$

30. The second ODE may be written

$$y_1'' = y_2' = y_1(2 - y_1)(2 + y_1).$$

Hence the critical points are  $(0, 0)$ ,  $(2, 0)$ ,  $(-2, 0)$ .

Linearization at  $(0, 0)$  gives the system

$$\begin{aligned}y_1' &= y_2 \\y_2' &= 4y_1.\end{aligned}$$

Since  $q = -4$ , this is a saddle point.

At  $(2, 0)$  the transformation is  $y_1 = 2 + \tilde{y}_1$ . Hence the right side of the second ODE becomes  $(2 + \tilde{y}_1)(-\tilde{y}_1)(4 + \tilde{y}_1)$ , so that the linearized system is

$$\begin{aligned}\tilde{y}_1' &= \tilde{y}_2 \\ \tilde{y}_2' &= -8\tilde{y}_1.\end{aligned}$$

Since  $\tilde{p} = 0$  and  $\tilde{q} = 8 > 0$ , this is a center.

Similarly at  $(-2, 0)$ , the transformation is  $y_1 = -2 + \tilde{y}_1$ , so that the right side becomes  $(-2 + \tilde{y}_1)(4 - \tilde{y}_1)\tilde{y}_1$ , and the linearized system is the same and thus has a center as its critical point.

32.  $\cos y_2 = 0$  when  $y_2 = (2n + 1)\pi/2$ , where  $n$  is any integer. This gives the location of the critical points, which lie on the  $y_2$ -axis  $y_1 = 0$  in the phase plane.

For  $(0, \frac{1}{2}\pi)$  the transformation is  $y_2 = \frac{1}{2}\pi + \tilde{y}_2$ . Now

$$\cos y_2 = \cos(\frac{1}{2}\pi + \tilde{y}_2) = -\sin \tilde{y}_2 \approx -\tilde{y}_2.$$

Hence the linearized system is

$$\begin{aligned}\tilde{y}_1' &= -\tilde{y}_2 \\ \tilde{y}_2' &= 3\tilde{y}_1.\end{aligned}$$

For its matrix

$$\begin{bmatrix} 0 & -1 \\ 3 & 0 \end{bmatrix}$$

we obtain  $\tilde{p} = 0$ ,  $\tilde{q} = 3 > 0$ , so that this is a center. Similarly, by periodicity, the critical points at  $(4n + 1)\pi/2$  are centers.

For  $(0, -\frac{1}{2}\pi)$  the transformation is  $y_2 = -\frac{1}{2}\pi + \tilde{y}_2$ . From

$$\cos y_2 = \cos(-\frac{1}{2}\pi + \tilde{y}_2) = \sin \tilde{y}_2 \approx \tilde{y}_2$$

we obtain the linearized system

$$\begin{aligned}\tilde{y}_1' &= \tilde{y}_2 \\ \tilde{y}_2' &= 3\tilde{y}_1\end{aligned}$$

with matrix

$$\begin{bmatrix} 0 & 1 \\ 3 & 0 \end{bmatrix}$$

for which  $\tilde{q} = -3 < 0$ , so that this point and the points with  $y_2 = (4n - 1)\pi/2$  on the  $y_2$ -axis are saddle points.

## CHAPTER 5 Series Solutions of ODEs. Special Functions

### Changes of Text

Minor changes, streamlining the text to make it more teachable, retaining the general structure of the chapter and the opportunity to familiarize the student with an overview of some of the techniques used in connection with **higher special functions**, also in connection with a CAS.

### SECTION 5.1. Power Series Method, page 167

**Purpose.** A simple introduction to the technique of the power series method in terms of simple examples whose solution the student knows very well.

### SOLUTIONS TO PROBLEM SET 5.1, page 170

$$2. y = a_0(1 - \frac{1}{2}x^2 + \frac{1}{8}x^4 - + \dots) = a_0e^{-x^2/2}$$

4. A general solution is  $y = c_1e^x + c_2e^{-x}$ . Both functions of the basis contain every power of  $x$ . The power series method automatically gives a general solution in which one function of the basis is even and the other is odd,

$$y = a_0(1 + \frac{1}{2}x^2 + \frac{1}{24}x^4 + \dots) + a_1(x + \frac{1}{6}x^3 + \frac{1}{120}x^5 + \dots) = a_0 \cosh x + a_1 \sinh x.$$

6.  $y = a_0(1 - 3x + \frac{9}{2}x^2 - \frac{11}{2}x^3 + \frac{51}{8}x^4 - + \dots)$ . Even if the solution turns out to be a known function, as in the present case,

$$y = a_0 \exp(-3x - x^3)$$

as obtained by separating variables, it is generally not easy to recognize this from a power series obtained. Of course, this is generally not essential, because the method is primarily designed for ODEs whose solutions define *new* functions. The task of recognizing a power series as a known function does however occur in practice, for instance, in proving that certain Bessel functions or hypergeometric functions reduce to familiar known functions (see Secs. 5.4, 5.5).

8. Substitution of the power series for  $y$  and  $y'$  gives

$$\begin{aligned} & (x^5 + 4x^3)(a_1 + 2a_2x + 3a_3x^2 + \dots) \\ &= 4a_1x^3 + 8a_2x^4 + (12a_3 + a_1)x^5 + \dots \\ &= (5x^4 + 12x^2)(a_0 + a_1x + a_2x^2 + \dots) \\ &= 12a_0x^2 + 12a_1x^3 + (12a_2 + 5a_0)x^4 + (12a_3 + 5a_1)x^5 + \dots \end{aligned}$$

Comparing coefficients of each power of  $x$ , we obtain

$$\begin{aligned} x^2: & a_0 = 0 \\ x^3: & 4a_1 = 12a_1, \quad a_1 = 0 \\ x^4: & 8a_2 = 12a_2 + 5a_0, \quad a_2 = 0 \\ x^5: & 12a_3 + a_1 = 12a_3 + 5a_1, \quad a_3 \text{ arbitrary} \\ x^6: & 16a_4 + 2a_2 = 12a_4 + 5a_2, \quad a_4 = 0 \\ x^7: & 3a_3 + 20a_5 = 5a_3 + 12a_5, \quad a_5 = \frac{1}{4}a_3 \\ x^8: & 4a_4 + 24a_6 = 5a_4 + 12a_6, \quad 24a_6 = 12a_6, \quad a_6 = 0, \quad \text{etc.} \end{aligned}$$

Here we see why a power series may terminate in some cases. The *answer* is

$$y = a_3(x^3 + \frac{1}{4}x^5).$$

$$10. y = a_0 \left( 1 - \frac{1}{2!}x^2 - \frac{1}{4!}x^4 - \frac{3}{6!}x^6 - \frac{3 \cdot 5}{8!}x^8 - \dots \right) + a_1x$$

$$12. s = x + \frac{1}{3}x^3 + \frac{2}{15}x^5, \quad s(\frac{1}{4}\pi) = 0.98674, \text{ a good approximation of the exact value } 1 = \tan \frac{1}{4}\pi.$$

Through these calculations of values the student should realize that a series can be used for numeric work just like a solution formula, with proper caution regarding convergence and accuracy.

$$14. s = 4 - x^2 - \frac{1}{3}x^3 + \frac{1}{30}x^5, \quad s(2) = -\frac{8}{5}. \text{ This } x \text{ is too large to give useful values. The exact solution}$$

$$y = (x - 2)^2 e^x$$

shows that the value should be 0.

$$16. s = \frac{15}{8}x - \frac{35}{4}x^3 + \frac{63}{8}x^5. \text{ This is the Legendre polynomial } P_5, \text{ a solution of this Legendre equation with parameter } n = 5, \text{ to be discussed in Sec. 5.3. The initial conditions were chosen accordingly, so that a second linearly independent solution (a Legendre function) does not appear in the answer. } s(0.5) = 0.089844.$$

18. This should encourage the student to use the library or to browse the Web, to learn where to find relevant information, to see in passing that there are various other expansions of functions (other series, products, continued fractions, etc.), and to take a look into various standard books. The limited task at hand should beware the student of getting lost in the flood of books. Lists such as the one required can be very helpful; similarly in connection with Fourier series.

## SECTION 5.2. Theory of the Power Series Method, page 170

**Purpose.** Review of power series and a statement of the basic existence theorem for power series solutions (without proof, which would exceed the level of our presentation).

### Main Content, Important Concepts

Radius of convergence (7)

Differentiation, multiplication of power series

Technique of index shift

Real analytic function (needed again in Sec. 5.4)

### Comment

Depending on the preparation of the class, skip the section or discuss just a few less known facts.

## SOLUTIONS TO PROBLEM SET 5.2, page 176

$$2. \left| \frac{a_{m+1}}{a_m} \right| = \frac{1/(3^{m+1}(m+2)^2)}{1/(3^m(m+1)^2)} \rightarrow \frac{1}{3}. \text{ Hence the convergence radius of the series, considered as a function of } t = (x+1)^2, \text{ is } 3. \text{ This gives the answer } \sqrt{3}. \text{ (In Probs. 3 and 6 the situation is similar.)}$$

$$4. 1$$

6.  $\infty$ , as is obvious from the occurrence of the factorial.  
 8. The quotient whose limit will give the reciprocal of the convergence radius is

$$\frac{(4m+4)!/(m+1)!^4}{(4m)!/(m!)^4} = \frac{(4m+4)(4m+3)(4m+2)(4m+1)}{(m+1)^4}.$$

The limit as  $m \rightarrow \infty$  is  $4^4 = 256$ . Hence the convergence radius is fairly small,  $1/256$ .

10. 0

12.  $\infty$

14.  $m - 3 = s$ ,  $m = s + 3$ ,  $\sum_{s=0}^{\infty} \frac{(-1)^{s+4}}{4^{s+3}} x^s$ ;  $R = 4$ . Of course,  $(-1)^{s+4} = (-1)^s$ .

16.  $a_0(1 - \frac{1}{6}x^3 + \frac{1}{180}x^6 - \frac{1}{12960}x^9 + \dots) + a_1(x - \frac{1}{12}x^4 + \frac{1}{504}x^7 - \dots)$ . This solution can be expressed in terms of Airy or Bessel functions, but in a somewhat complicated fashion, so that in many cases for numeric and other purposes it will be practical to use the power series (a partial sum with sufficiently many terms) directly.

18. We obtain

$$a_0(1 - \frac{1}{6}x^3 - \frac{1}{24}x^4 - \frac{1}{120}x^5 + \dots) + a_1(x + \frac{1}{2}x^2 + \frac{1}{6}x^3 - \frac{1}{24}x^4 - \frac{1}{30}x^5 - \dots).$$

The solution has a (complicated) representation in terms of Airy functions, and the remark in the solution of Prob. 16 applies equally well, even more. The students should also be told that many ODEs can be reduced to the standard ones that we discuss in the text, so that in this way they can save work in deriving formulas for the various solutions.

20. We obtain

$$a_0(1 - \frac{1}{2}x^2 + \frac{5}{24}x^4 - \frac{1}{16}x^6 + \dots) + a_1(x - \frac{1}{2}x^3 + \frac{7}{40}x^5 - \frac{11}{240}x^7 + \dots).$$

This solution can be expressed in terms of Bessel and exponential functions.

22. We obtain

$$a_0(1 + x^2 + \frac{1}{2}x^4 + \frac{1}{6}x^6 + \frac{1}{24}x^8 + \dots) + a_1(x + x^3 + \frac{1}{2}x^5 + \frac{1}{6}x^7 + \dots).$$

This can be written as  $(a_0 + a_1x)$  times the same power series, which obviously represents  $e^{x^2}$ .

24. **Team Project.** The student should see that power series reveal many basic properties of the functions they represent. Familiarity with the functions considered should help students in understanding the basic idea without being irritated by unfamiliar notions or notations and more involved formulas. (d) illustrates that not *all* properties become visible directly from the series. For instance, the periodicity of  $\cos x$  and  $\sin x$ , the boundedness, and the location of the zeros are properties of this kind.

### SECTION 5.3. Legendre's Equation. Legendre Polynomials $P_n(x)$ , page 177

**Purpose.** This section on Legendre's equation, one of the most important ODEs, and its solutions is more than just an exercise on the power series method. It should give the student a feel for the usefulness of power series in exploring properties of **special functions** and for the wealth of relations between functions of a one-parameter family (with parameter  $n$ ).

Legendre's equation occurs again in Secs. 5.7 and 5.8.

#### Comment on Literature and History

For literature on Legendre's equation and its solutions, see Refs. [GR1] and [GR10].

Legendre's work on the subject appeared in 1785 and Rodrigues's contribution (see Prob. 8), in 1816.

### SOLUTIONS TO PROBLEM SET 5.3, page 180

4. This follows from (4), giving the limit 1 as  $s \rightarrow \infty$  (note that  $n$  is fixed):

$$\left| \frac{a_{s+2}}{a_s} \right| = \frac{|n-s|(n+s+1)}{(s+2)(s+1)} \rightarrow 1.$$

8. We have

$$(x^2 - 1)^n = \sum_{m=0}^n (-1)^m \binom{n}{m} (x^2)^{n-m}.$$

Differentiating  $n$  times, we can express the product of occurring factors  $(2n-2m)(2n-2m-1) \cdots$  as a quotient of factorials and get

$$\frac{d^n}{dx^n} [(x^2 - 1)^n] = \sum_{m=0}^M (-1)^m \frac{n!}{m!(n-m)!} \frac{(2n-2m)!}{(n-2m)!} x^{n-2m}$$

with  $M$  as in (11). Divide by  $n!2^n$ . Then the left side equals the right side in Rodrigues's formula, and the right side equals the right side of (11).

10. We know that at the endpoints of the interval  $-1 \leq x \leq 1$  all the Legendre polynomials have the values  $\pm 1$ . It is interesting that in between they are strictly less than 1 in absolute value ( $P_0$  excluded). Furthermore, absolute values between  $\frac{1}{2}$  and 1 are taken only near the endpoints, so that in an interval, say  $-0.8 \leq x \leq 0.8$ , they are less than  $\frac{1}{2}$  in absolute value ( $P_0, P_1, P_2$  excluded).

14. **Team Project.** (a) Following the hint, we obtain

$$\begin{aligned} \text{(A)} \quad (1 - 2xu + u^2)^{-1/2} &= 1 + \frac{1}{2} (2xu - u^2) \\ &+ \cdots + \frac{1 \cdot 3 \cdots (2n-1)}{2 \cdot 4 \cdots (2n)} (2xu - u^2)^n + \cdots \end{aligned}$$

and for the general term on the right,

$$\begin{aligned} \text{(B)} \quad (2xu - u^2)^m &= (2x)^m u^m - m(2x)^{m-1} u^{m+1} \\ &+ \frac{m(m-1)}{2!} (2x)^{m-2} u^{m+2} + \cdots \end{aligned}$$

Now  $u^n$  occurs in the first term of the expansion (B) of  $(2xu - u^2)^n$ , in the second term of the expansion (B) of  $(2xu - u^2)^{n-1}$ , and so on. From (A) and (B) we see that the coefficients of  $u^n$  in those terms are

$$\begin{aligned} &\frac{1 \cdot 3 \cdots (2n-1)}{2 \cdot 4 \cdots (2n)} (2x)^n = a_n x^n \quad [\text{see (8)}], \\ &- \frac{1 \cdot 3 \cdots (2n-3)}{2 \cdot 4 \cdots (2n-2)} (n-1)(2x)^{n-2} = - \frac{2n}{2n-1} \frac{n-1}{4} a_n x^{n-2} = a_{n-2} x^{n-2} \end{aligned}$$

and so on. This proves the assertion.

(b) Set  $u = r_1 r_2$  and  $x = \cos \theta$ .

(c) Use the formula for the sum of the geometric series and set  $x = 1$  and  $x = -1$ . Then set  $x = 0$  and use

$$(1 + u^2)^{-1/2} = \sum \binom{-1/2}{m} u^{2m}.$$

(d) Abbreviate  $1 - 2xu + u^2 = U$ . Differentiation of (13) with respect to  $u$  gives

$$-\frac{1}{2} U^{-3/2}(-2x + 2u) = \sum_{n=0}^{\infty} nP_n(x)u^{n-1}.$$

Multiply this equation by  $U$  and represent  $U^{-1/2}$  by (13):

$$(x - u) \sum_{n=0}^{\infty} P_n(x)u^n = (1 - 2xu + u^2) \sum_{n=0}^{\infty} nP_n(x)u^{n-1}.$$

In this equation,  $u^n$  has the coefficients

$$xP_n(x) - P_{n-1}(x) = (n + 1)P_{n+1}(x) - 2nP_n(x) + (n - 1)P_{n-1}(x).$$

Simplifying gives the asserted Bonnet recursion.

#### SECTION 5.4. Frobenius Method, page 182

**Purpose.** To introduce the student to the Frobenius method (an extension of the power series method), which is important for ODEs with coefficients that have **singularities**, notably **Bessel's equation**, so that the power series method can no longer handle them. This extended method requires more patience and care.

#### Main Content, Important Concepts

Regular and singular points

Indicial equation, three cases of roots (one unexpected)

Frobenius theorem, forms of bases in those cases

**Short Courses.** Take a quick look at those bases in Frobenius's theorem, say how it fits with the Euler–Cauchy equation, and omit everything else.

#### Comment on “Regular Singular” and “Irregular Singular”

These terms are used in some books and papers, but there is hardly any need for confusing the student by using them, simply because we cannot do (and don't do) anything about “irregular singular points.” A simple use of “regular” and “singular” (as in complex analysis, where holomorphic functions are also known as “regular analytic functions”) may thus be the best terminology.

#### Comment on Footnote 5

Gauss was born in Braunschweig (Brunswick) in 1777. At the age of 16, in 1793 he discovered the method of least squares (Secs. 20.5, 25.9). From 1795 to 1798 he studied at Göttingen. In 1799 he obtained his doctor's degree at Helmstedt. In 1801 he published his first masterpiece, *Disquisitiones arithmeticae* (*Arithmetical Investigations*, begun in 1795), thereby initiating modern number theory. In 1801 he became generally known when his calculations enabled astronomers (Zach, Olbers) to rediscover the planet Ceres, which had been discovered in 1801 by Piazzi at Palermo but had been visible only very briefly. He became the director of the Göttingen observatory in 1807 and remained there until his

death. In 1809 he published his famous *Theoria motus corporum coelestium in sectionibus conicis solem ambientium* (*Theory of the Heavenly Bodies Moving About the Sun in Conic Sections*; Dover Publications, 1963), resulting from his further work in astronomy. In 1814 he developed his method of numeric integration (Sec. 19.5). His *Disquisitiones generales circa superficies curvas* (*General Investigations Regarding Curved Surfaces*, 1828) represents the foundation of the differential geometry of surfaces and contributes to conformal mapping (Sec. 17.1). His clear conception of the complex plane dates back to his thesis, whereas his first publication on this topic was not before 1831. This is typical: Gauss left many of his most outstanding results (non-Euclidean geometry, elliptic functions, etc.) unpublished. His paper on the hypergeometric series published in 1812 is the first systematic investigation into the convergence of a series. This series, generalizing the geometric series, allows a study of many special functions from a common point of view.

### SOLUTIONS TO PROBLEM SET 5.4, page 187

2. The indicial equation is  $r(r-1) - 2 = (r-2)(r+1) = 0$ . The roots are  $r_1 = 2$ ,  $r_2 = -1$ . This is Case 3.  $y_1 = (x+2)^2$ ,  $y_2 = 1/(x+2)$ . Check: Set  $x+2 = t$  to get an Euler–Cauchy equation,  $t^2y'' - 2y = 0$ .

4. To determine  $r_1, r_2$  from (4), we write the ODE in the form (1'),

$$x^2y'' + \left(\frac{3}{2}x - 2x^2\right)y' + \left(x^2 - \frac{3}{2}x\right)y = 0.$$

Then we see that  $b = \frac{3}{2} - 2x$ ,  $b_0 = \frac{3}{2}$ ,  $c_0 = 0$ , hence

$$r(r-1) + \frac{3}{2}r = r\left(r + \frac{1}{2}\right) = 0, \quad r_1 = 0, \quad r_2 = -\frac{1}{2}.$$

We obtain the first solution by substituting (2) with  $r = 0$  into the ODE (which we can take in the given form):

$$\sum_{m=0}^{\infty} [2m(m-1)a_m x^{m-1} + 3ma_m x^{m-1} - 4ma_m x^m + 2a_m x^{m+1} - 3a_m x^m] = 0.$$

Hence equating the sum of the coefficients of the power  $x^s$  to zero, we have

$$2(s+1)a_{s+1} + 3(s+1)a_{s+1} - 4sa_s + 2a_{s-1} - 3a_s = 0.$$

Combining terms, we can write this in the form

$$(2s^2 + 5s + 3)a_{s+1} - (4s + 3)a_s + 2a_{s-1} = 0.$$

For  $s = 0$ , since there is no coefficient  $a_{-1}$ , we obtain  $3a_1 - 3a_0 = 0$ . Hence  $a_1 = a_0$ . For  $s = 1$  we obtain

$$10a_2 - 7a_1 + 2a_0 = 0, \quad 10a_2 = 5a_0, \quad a_2 = \frac{1}{2}a_0.$$

This already was a special case of the recurrence formula obtained by solving the previous equation for  $a_{s+1}$ , namely,

$$a_{s+1} = \frac{1}{(s+1)(2s+3)} [(4s+3)a_s - 2a_{s-1}].$$

For  $s = 2$ , taking  $a_0 = 1$  this gives after simplification  $a_3 = 1/3!$  and in general  $a_{s+1} = 1/(s+1)!$ . Hence a first solution is  $y_1(x) = e^x$ .

**Second Solution.** Since  $r_1 = 0$ ,  $r_2 = -\frac{1}{2}$ , we are in Case 1 and have to substitute

$$y_2(x) = x^{-1/2}(A_0 + A_1x + \dots)$$



and determine these coefficients. We first have, using  $m$  as the summation letter, as before,

$$\sum_{m=0}^{\infty} [2(m - \frac{1}{2})(m - \frac{3}{2})A_m x^{m-3/2} + 3(m - \frac{1}{2})A_m x^{m-3/2} - 4(m - \frac{1}{2})A_m x^{m-1/2} + 2A_m x^{m+1/2} - 3A_m x^{m-1/2}] = 0.$$

Hence equating the sum of the coefficients of the power  $x^{s-1/2}$  to zero, we obtain

$$2(s + \frac{1}{2})(s - \frac{1}{2})A_{s+1} + 3(s + \frac{1}{2})A_{s+1} - 4(s - \frac{1}{2})A_s + 2A_{s-1} - 3A_s = 0.$$

Solving for  $A_{s+1}$  in terms of  $A_s$  and  $A_{s-1}$ , we obtain

$$A_{s+1} = \frac{1}{(s+1)(2s+1)} [(4s+1)A_s - 2A_{s-1}].$$

Noting that there is no  $A_{-1}$ , we successively get, taking  $A_0 = 1$ ,

$$A_1 = A_0 = 1 \quad (s=0), \quad A_2 = \frac{1}{2 \cdot 3} [5A_1 - 2A_0] = \frac{1}{2!} \quad (s=1)$$

$$A_3 = 1/3!, \quad A_4 = 1/4!$$

etc. This gives as a second linearly independent solution  $y_2 = e^x/\sqrt{x}$ .

6. Substitution of (2) and the derivatives (2\*) gives

$$(A) \quad 4 \sum_{m=0}^{\infty} (m+r)(m+r-1)a_m x^{m+r-1} + 2 \sum_{m=0}^{\infty} (m+r)a_m x^{m+r-1} + \sum_{m=0}^{\infty} a_m x^{m+r} = 0.$$

Writing this out, we have

$$4r(r-1)a_0 x^{r-1} + 4(r+1)ra_1 x^r + 4(r+2)(r+1)a_2 x^{r+1} + \dots$$

$$+ 2ra_0 x^{r-1} + 2(r+1)a_1 x^r + 2(r+2)a_2 x^{r+1} + \dots$$

$$+ a_0 x^r + a_1 x^{r+1} + \dots = 0.$$

By equating the sum of the coefficients of  $x^{r-1}$  to zero we obtain the indicial equation

$$4r(r-1) + 2r = 0; \quad \text{thus} \quad r^2 - \frac{1}{2}r = 0.$$

The roots are  $r_1 = \frac{1}{2}$  and  $r_2 = 0$ . This is Case 1.

By equating the sum of the coefficients of  $x^{r+s}$  in (A) to zero we obtain (take  $m+r-1 = r+s$ , thus  $m = s+1$  in the first two series and  $m = s$  in the last series)

$$4(s+r+1)(s+r)a_{s+1} + 2(s+r+1)a_{s+1} + a_s = 0.$$

By simplification we find that this can be written

$$4(s+r+1)(s+r+\frac{1}{2})a_{s+1} + a_s = 0.$$

We solve this for  $a_{s+1}$  in terms of  $a_s$ :

$$(B) \quad a_{s+1} = -\frac{a_s}{(2s+2r+2)(2s+2r+1)} \quad (s=0, 1, \dots).$$

**First solution.** We determine a first solution  $y_1(x)$  corresponding to  $r_1 = \frac{1}{2}$ . For  $r = r_1$ , formula (B) becomes

$$a_{s+1} = -\frac{a_s}{(2s+3)(2s+2)} \quad (s = 0, 1, \dots).$$

From this we get successively

$$a_1 = -\frac{a_0}{3 \cdot 2}, \quad a_2 = -\frac{a_1}{5 \cdot 4}, \quad a_3 = -\frac{a_2}{7 \cdot 6}, \quad \text{etc.}$$

In many practical situations an explicit formula for  $a_m$  will be rather complicated. Here it is simple: by successive substitution we get

$$a_1 = -\frac{a_0}{3!}, \quad a_2 = \frac{a_0}{5!}, \quad a_3 = -\frac{a_0}{7!}, \quad \dots$$

and in general, taking  $a_0 = 1$ ,

$$a_m = \frac{(-1)^m}{(2m+1)!} \quad (m = 0, 1, \dots).$$

Hence the first solution is

$$y_1(x) = x^{1/2} \sum_{m=0}^{\infty} \frac{(-1)^m}{(2m+1)!} x^m = \sqrt{x} \left( 1 - \frac{1}{6}x + \frac{1}{120}x^2 - + \dots \right) = \sin \sqrt{x}.$$

**Second Solution.** If you recognize  $y_1$  as a familiar function, apply reduction of order (see Sec. 2.1). If not, start from (6) with  $r_2 = 0$ . For  $r = r_2 = 0$ , formula (B) [with  $A_{s+1}$  and  $A_s$  instead of  $a_{s+1}$  and  $a_s$ ] becomes

$$A_{s+1} = -\frac{A_s}{(2s+2)(2s+1)} \quad (s = 0, 1, \dots).$$

From this we get successively

$$A_1 = -\frac{A_0}{2 \cdot 1}, \quad A_2 = -\frac{A_1}{4 \cdot 3}, \quad A_3 = -\frac{A_2}{6 \cdot 5},$$

and by successive substitution we have

$$A_1 = -\frac{A_0}{2!}, \quad A_2 = \frac{A_0}{4!}, \quad A_3 = -\frac{A_0}{6!}, \quad \dots$$

and in general, taking  $A_0 = 1$ ,

$$A_m = \frac{(-1)^m}{(2m)!}.$$

Hence the second solution, of the form (6) with  $r_2 = 0$ , is

$$y_2(x) = \sum_{m=0}^{\infty} \frac{(-1)^m}{(2m)!} x^m = 1 - \frac{1}{2}x + \frac{1}{24}x^2 - + \dots = \cos \sqrt{x}.$$

8.  $y_1 = x \left( 1 + \frac{x}{1!2!} + \frac{x^2}{2!3!} + \frac{x^3}{3!4!} + \dots \right)$ . From this and (10) we obtain

$$y_2 = y_1 \ln x + 1 - \frac{3}{4}x^2 - \frac{7}{36}x^3 - \frac{35}{1728}x^4 - \dots$$

In the present case,  $k$  and  $A_1$  in (10) are at first arbitrary, and our  $y_2$  corresponds to the choice  $k = 1$  and  $A_1 = 0$ . Choosing  $A_1 \neq 0$ , we obtain the above expression for  $y_2$  plus  $A_1 y_1$ .

10.  $b_0 = 0, c_0 = -2, r(r-1) - 2 = (r-2)(r+1), r_1 = 2, r_2 = -1,$

$$y_1 = x^2 \left( 1 - \frac{1}{2}x^2 + \frac{9}{56}x^4 - \frac{13}{336}x^6 + \cdots \right)$$

$$y_2 = \frac{1}{x} \left( 12 - 6x^2 + \frac{9}{2}x^4 - \frac{7}{4}x^6 + \cdots \right).$$

12.  $b_0 = 6, c_0 = 6, r_1 = -2, r_2 = -3;$  the series are

$$y_1 = \frac{1}{x^2} - \frac{2}{3} + \frac{2}{15}x^2 - \frac{4}{315}x^4 + \cdots = \frac{1}{2} \frac{\sin 2x}{x^3}$$

$$y_2 = \frac{1}{x^3} - \frac{2}{x} + \frac{2}{3}x - \frac{4}{45}x^3 + \cdots = \frac{\cos 2x}{x^3}.$$

14. We obtain

$$y_1 = 1 + \frac{x^2}{2^2} + \frac{x^4}{(2 \cdot 4)^2} + \frac{x^6}{(2 \cdot 4 \cdot 6)^2} + \cdots,$$

$$y_2 = y_1 \ln x - \frac{x^2}{4} - \frac{3x^4}{8 \cdot 16} - \frac{11x^6}{64 \cdot 6 \cdot 36} - \cdots.$$

16. We obtain

$$y_1 = \frac{1}{x} + \frac{x}{6} + \frac{x^3}{120} + \frac{x^5}{5040} + \cdots = \frac{\sinh x}{x^2}$$

$$y_2 = \frac{1}{x^2} + \frac{1}{2} + \frac{x^2}{24} + \frac{x^4}{720} + \cdots = \frac{\cosh x}{x^2}.$$

18. **Team Project.** (b) In (7b) of Sec. 5.2,

$$\frac{a_{n+1}}{a_n} = \frac{(a+n)(b+n)}{(n+1)(c+n)} \rightarrow 1,$$

hence  $R = 1$ .

- (c) In the third and fourth lines,

$$\arctan x = x - \frac{1}{3}x^3 + \frac{1}{5}x^5 - \frac{1}{7}x^7 + \cdots \quad (|x| < 1)$$

$$\arcsin x = x + \frac{1}{2 \cdot 3}x^3 + \frac{1 \cdot 3}{2 \cdot 4 \cdot 5}x^5 + \frac{1 \cdot 3 \cdot 5}{2 \cdot 4 \cdot 6 \cdot 7}x^7 + \cdots \quad (|x| < 1).$$

- (d) The roots can be read off from (15), brought to the form (1') by multiplying it by  $x$  and dividing by  $1-x$ ; then  $b_0 = c$  in (4) and  $c_0 = 0$ .

20.  $a = 1, b = 1, c = -\frac{1}{2}, y = AF(1, 1, -\frac{1}{2}; x) + Bx^{3/2}F(\frac{5}{2}, \frac{5}{2}, \frac{5}{2}; x)$

22.  $y = c_1F(-1, \frac{1}{3}, \frac{1}{3}; t+1) + c_2(t+1)^{2/3}F(-\frac{1}{3}, 1, \frac{5}{3}; t+1)$

24.  $t^2 - 3t + 2 = (t-1)(t-2) = 0$ . Hence the transformation is  $x = t - 1$ . It gives the ODE

$$4(x^2 - x)y'' - 2y' + y = 0.$$

To obtain the standard form of the hypergeometric equation, multiply this ODE by  $-\frac{1}{4}$ . It is clear that the factor 4 must be absorbed, but don't forget the factor  $-1$ ; otherwise your values for  $a, b, c$  will not be correct. The result is

$$x(1-x)y'' + \frac{1}{2}y' - \frac{1}{4}y = 0.$$

Hence  $ab = 1/4$ ,  $b = \frac{1}{4a}$ ,  $a + b + 1 = a + \frac{1}{4a} + 1 = 0$ ,  $a = -\frac{1}{2}$ ,  $b = -\frac{1}{2}$ ,  $c = \frac{1}{2}$ .

This gives

$$y_1 = F\left(-\frac{1}{2}, -\frac{1}{2}, \frac{1}{2}; t - 1\right).$$

In  $y_2$  we have  $a - c + 1 = -\frac{1}{2} - \frac{1}{2} + 1 = 0$ ; hence  $y_2$  terminates after the first term, and, since  $1 - c = \frac{1}{2}$ ,

$$y_2 = x^{1/2} \cdot 1 = \sqrt{t - 1}.$$

### SECTION 5.5. Bessel's Equation. Bessel Functions $J_\nu(x)$ , page 189

**Purpose.** To derive the Bessel functions of the first kind  $J_\nu$  and  $J_{-\nu}$  by the Frobenius method. (This is a major application of that method.) To show that these functions constitute a basis if  $\nu$  is not an integer but are linearly dependent for integer  $\nu = n$  (so that we must look later, in Sec. 5.6, for a second linearly independent solution). To show that various ODEs can be reduced to Bessel's equation (see Problem Set 5.5).

#### Main Content, Important Concepts

Derivation just mentioned

Linear independence of  $J_\nu$  and  $J_{-\nu}$  if  $\nu$  is not an integer

Linear dependence of  $J_\nu$  and  $J_{-\nu}$  if  $\nu = n = 1, 2, \dots$

Gamma function as a tool

**Short Courses.** No derivation of any of the series. Discussion of  $J_0$  and  $J_1$  (which are similar to cosine and sine). Mention Theorem 2.

#### Comment on Special Functions

Since various institutions no longer find time to offer a course in special functions, Bessel functions may give another opportunity (together with Sec. 5.3) for getting at least some feel for the flavor of the theory of special functions, which will continue to be of significance to the engineer and physicist. For this reason we have added some material on basic relations for Bessel functions in this section.

### SOLUTIONS TO PROBLEM SET 5.5, page 197

2. We obtain the following values. Note that the error of this very crude approximation is rather small.

| $x$ | Approximation | Exact (4D) | Relative Error |
|-----|---------------|------------|----------------|
| 0   | 1.0000        | 1.0000     | 0              |
| 0.1 | 0.9975        | 0.9975     | 0              |
| 0.2 | 0.9900        | 0.9900     | 0              |
| 0.3 | 0.9775        | 0.9776     | 0.0001         |
| 0.4 | 0.9600        | 0.9604     | 0.0004         |
| 0.5 | 0.9375        | 0.9385     | 0.0010         |
| 0.6 | 0.9100        | 0.9120     | 0.0020         |
| 0.7 | 0.8775        | 0.8812     | 0.0042         |
| 0.8 | 0.8400        | 0.8463     | 0.0074         |
| 0.9 | 0.7975        | 0.8075     | 0.0124         |
| 1.0 | 0.7500        | 0.7652     | 0.0199         |

4. Zeros of Bessel functions are important, as the student will see in connection with vibrating membranes in Chap. 12, and there are other applications. These numeric problems (2–4) should give the student a feel for the applicability and accuracy of the formulas discussed in the text. In the present problem this refers to the asymptotic formula (14). A corresponding formula for  $Y$  is included in the next problem set.

#### Zeros of $J_0(x)$

| Approximation (14) | Exact Value | Error   |
|--------------------|-------------|---------|
| 2.35619            | 2.40483     | 0.04864 |
| 5.49779            | 5.52008     | 0.02229 |
| 8.63938            | 8.65373     | 0.01435 |
| 11.78097           | 11.79153    | 0.01056 |

#### Zeros of $J_1(x)$

| Approximation (14) | Exact Value | Error    |
|--------------------|-------------|----------|
| 3.92699            | 3.83171     | -0.09528 |
| 7.06858            | 7.01559     | -0.05299 |
| 10.21018           | 10.17347    | -0.03671 |
| 13.35177           | 13.32369    | -0.02808 |

6.  $y = c_1 J_{1/4}(x) + c_2 J_{-1/4}(x)$
8.  $y = c_1 J_1(2x + 1)$ ;  $J_1$  and  $J_{-1}$  are linearly dependent by Theorem 2; actually,  $J_{-1}(x) = -J_1(x)$ .
10.  $y = c_1 J_{1/2}(\frac{1}{2}x) + c_2 J_{-1/2}(\frac{1}{2}x) = x^{-1/2}(\tilde{c}_1 \sin \frac{1}{2}x + \tilde{c}_2 \cos \frac{1}{2}x)$
12.  $y = c_1 J_\nu(x^2) + c_2 J_{-\nu}(x^2)$ ,  $\nu \neq 0, \pm 1, \pm 2, \dots$
14.  $y = c_1 J_{1/3}(e^x) + c_2 J_{-1/3}(e^x)$
16.  $y = x^{1/4}(c_1 J_{1/4}(x^{1/4}) + c_2 J_{-1/4}(x^{1/4}))$
18.  $y = c_1 J_0(4x^{1/4})$ . Second independent solution not yet available.
20.  $y = x^\nu(c_1 J_\nu(x^\nu) + c_2 J_{-\nu}(x^\nu))$ ,  $\nu \neq 0, \pm 1, \pm 2, \dots$
22.  $J'_0 = 0$  at least once between two consecutive zeros of  $J_0$ , by Rolle's theorem. Now (24b) with  $\nu = 0$  is

$$J'_0 = -J_1.$$

Together,  $J_1$  has at least one zero between two consecutive zeros of  $J_0$ .

Furthermore,  $(xJ_1)' = 0$  at least once between two consecutive zeros of  $xJ_1$ , hence of  $J_1$  (also at  $x = 0$  since  $J_1(0) = 0$ ), by Rolle's theorem. Now (24a) with  $\nu = 1$  is

$$(xJ_1)' = xJ_0.$$

Together,  $J_0$  has at least one zero between two consecutive zeros of  $J_1$ .

24. (24b) with  $\nu - 1$  instead of  $\nu$  is

$$(x^{-\nu+1}J_{\nu-1})' = -x^{-\nu+1}J_\nu.$$

Now use (24a)  $(x^\nu J_\nu)' = x^\nu J_{\nu-1}$ ; solve it for  $J_{\nu-1}$  to obtain

$$J_{\nu-1} = x^{-\nu}(x^\nu J_\nu)' = x^{-\nu}(\nu x^{\nu-1}J_\nu + x^\nu J'_\nu) = \nu x^{-1}J_\nu + J'_\nu.$$

Substitute this into the previous equation on the left. Then perform the indicated differentiation:

$$\begin{aligned}(x^{-\nu+1}(\nu x^{-1}J_\nu + J'_\nu))' &= (\nu x^{-\nu}J_\nu + x^{-\nu+1}J'_\nu)' \\ &= -\nu^2 x^{-\nu-1}J_\nu + \nu x^{-\nu}J'_\nu + (-\nu + 1)x^{-\nu}J'_\nu + x^{-\nu+1}J''_\nu.\end{aligned}$$

Equating this to the right side of the first equation and dividing by  $x^{-\nu+1}$  gives

$$J''_\nu + \frac{1}{x} J'_\nu - \frac{\nu^2}{x^2} J_\nu = -J_\nu.$$

Taking the term on the right to the left (with a plus sign) and multiplying by  $x^2$  gives (1).

26. We obtain

$$\begin{aligned}\int x^{-1}J_4(x) dx &= \int x^2(x^{-3}J_4(x)) dx && \text{(trivial)} \\ &= \int x^2(-x^{-3}J_3(x))' dx && \text{((24b) with } \nu = 3) \\ &= -x^2x^{-3}J_3(x) + \int 2xx^{-3}J_3(x) dx && \text{(by parts)} \\ &= -x^{-1}J_3(x) + 2 \int x^{-2}J_3(x) dx && \text{(simplify)} \\ &= -x^{-1}J_3(x) + 2 \int (-x^{-2}J_2)' dx && \text{((24b) with } \nu = 2) \\ &= -x^{-1}J_3(x) - 2x^{-2}J_2(x) + c && \text{(trivial).}\end{aligned}$$

28. Use (24d) to get

$$\begin{aligned}\int J_5(x) dx &= -2J_4(x) + \int J_3(x) dx \\ &= -2J_4(x) - 2J_2(x) + \int J_1(x) dx \\ &= -2J_4(x) - 2J_2(x) - J_0(x) + c.\end{aligned}$$

30. For  $\nu = \pm\frac{1}{2}$  the ODE (27) in Prob. 29 becomes

$$u'' + u = 0.$$

Hence for  $y$  we obtain the general solution

$$y = x^{-1/2}u = x^{-1/2}(A \cos x + B \sin x).$$

We can now obtain  $A$  and  $B$  by comparing with the first term in (20). Using  $\Gamma(\frac{3}{2}) = \frac{1}{2}\Gamma(\frac{1}{2}) = \frac{1}{2}\sqrt{\pi}$  (see (26)) we obtain for  $\nu = \frac{1}{2}$  the first term

$$x^{1/2}/(2^{1/2} \cdot \frac{1}{2}\Gamma(\frac{1}{2})) = \sqrt{2x/\pi}.$$

This gives (25a) because the series of  $\sin x$  starts with the power  $x$ .

For  $\nu = -\frac{1}{2}$  the first term is  $x^{-1/2}/(2^{1/2} \cdot \frac{1}{2}\Gamma(\frac{1}{2})) = \sqrt{2/\pi x}$ . This gives (25b).

32. **Team Project.** (a) Since  $\alpha$  is assumed to be small, we can regard  $W(x)$  to be approximately equal to the tension acting tangentially in the moving cable. The restoring force is the horizontal component of the tension. For the difference in force we use the mean value theorem of differential calculus. By Newton's second law this equals the mass  $\rho \Delta x$  times the acceleration  $u_{tt}$  of this portion of the cable. The substitution of  $u$  first gives

$$-\omega^2 y \cos(\omega t + \delta) = g[(L-x)y']' \cos(\omega t + \delta).$$

Now drop the cosine factor, perform the differentiation, and order the terms.

(b)  $dx = -dz$  and by the chain rule,

$$z \frac{d^2y}{dz^2} + \frac{dy}{dz} + \lambda^2 y = 0.$$

In the next transformation the chain rule gives

$$\frac{dy}{dz} = \frac{dy}{ds} \lambda z^{-1/2}, \quad \frac{d^2y}{dz^2} = \frac{d^2y}{ds^2} \lambda^2 z^{-1} - \frac{1}{2} \frac{dy}{ds} \lambda z^{-3/2}.$$

Substitution gives

$$\lambda^2 \frac{d^2y}{ds^2} + \left( -\frac{1}{2} \lambda z^{-1/2} + \lambda z^{-1/2} \right) \frac{dy}{ds} + \lambda^2 y = 0.$$

Now divide by  $\lambda^2$  and remember that  $s = 2\lambda z^{1/2}$ . This gives Bessel's equation.

(c) This follows from the fact that the upper end ( $x = 0$ ) is fixed. The second normal mode looks similar to the portion of  $J_0$  between the second positive zero and the origin. Similarly for the third normal mode. The first positive zero is about 2.405. For the cable of length 2 m this gives the frequency

$$\frac{\omega}{2\pi} = \frac{2.405}{2 \cdot 2\pi\sqrt{L/g}} = \frac{2.405}{4\pi\sqrt{2.00/9.80}} = 0.424 [\text{sec}^{-1}] = 25.4 [\text{cycles/min}].$$

Similarly, we obtain 11.4 cycles/min for the long cable.

## SECTION 5.6. Bessel Functions of the Second Kind $Y_\nu(x)$ , page 198

**Purpose.** Derivation of a second independent solution, which is still missing in the case of  $\nu = n = 0, 1, \dots$ .

### Main Content

- Detailed derivation of  $Y_0(x)$
- Cursory derivation of  $Y_n(x)$  for any  $n$
- General solution (9) valid for all  $\nu$ , integer or not

**Short Courses.** Omit this section.

### Comment on Hankel Functions and Modified Bessel Functions

These are included for completeness, but will not be needed in our further work.

## SOLUTIONS TO PROBLEM SET 5.6, page 202

2.  $y = c_1 J_{1/3}(3x) + c_2 Y_{1/3}(3x)$ .  $J_{-1/3}$  could be used.
4.  $y = c_1 J_0(12\sqrt{x}) + c_2 Y_0(12\sqrt{x})$
6.  $y = c_1 J_{1/3}(\frac{1}{3}x^3) + c_2 Y_{1/3}(\frac{1}{3}x^3)$ .  $J_{-1/3}$  could be used.
8.  $y = \sqrt{x}(c_1 J_{1/4}(x^2) + c_2 Y_{1/4}(x^2))$ .  $J_{-1/4}$  could be used.
10.  $y = x^{-3}(c_1 J_3(2x) + c_2 Y_3(2x))$
12. **CAS Experiment.** (a)  $Y_0$  and  $Y_1$ , similarly as for  $J_0$  and  $J_1$ .  
 (b) Accuracy is best for  $Y_0$ .  $x_n$  increases with  $n$ ; actual values will depend on the scales used for graphing.

| $m$ | $Y_0$   |        | $Y_1$   |        | $Y_2$   |        |
|-----|---------|--------|---------|--------|---------|--------|
|     | By (11) | Exact  | By (11) | Exact  | By (11) | Exact  |
| 1   | 0.785   | 0.894  | 2.356   | 2.197  | 3.927   | 3.384  |
| 2   | 3.9270  | 3.958  | 5.498   | 5.430  | 7.0686  | 6.794  |
| 3   | 7.0686  | 7.086  | 8.639   | 8.596  | 10.210  | 10.023 |
| 4   | 10.210  | 10.222 | 11.781  | 11.749 | 13.352  | 13.210 |
| 5   | 13.352  | 13.361 | 14.923  | 14.897 | 16.493  | 16.379 |
| 6   | 16.493  | 16.501 | 18.064  | 18.043 | 19.635  | 19.539 |
| 7   | 19.635  | 19.641 | 21.206  | 21.188 | 22.777  | 22.694 |
| 8   | 22.777  | 22.782 | 24.347  | 24.332 | 25.918  | 25.846 |
| 9   | 25.918  | 25.923 | 27.489  | 27.475 | 29.060  | 28.995 |
| 10  | 29.060  | 29.064 | 30.631  | 30.618 | 32.201  | 32.143 |

These values show that the accuracy increases with  $x$  (for fixed  $n$ ), as expected. For a fixed  $m$  (number of zero) it decreases with increasing  $n$  (order of  $Y_n$ ).

14. For  $x \neq 0$  all the terms of the series are real and positive.

### SECTION 5.7. Sturm–Liouville Problems. Orthogonal Functions, page 203

**Purpose.** Discussion of eigenvalue problems for ordinary second-order ODEs (1) under boundary conditions (2).

#### Main Content, Important Concepts

Sturm–Liouville equations, Sturm–Liouville problem

Reality of eigenvalues

Orthogonality of eigenfunctions

Orthogonality of Legendre polynomials and Bessel functions

**Short Courses.** Omit this section.

#### Comment on Importance

This theory owes its significance to two factors. On the one hand, boundary value problems involving practically important ODEs (Legendre's, Bessel's, etc.) can be cast into Sturm–Liouville form, so that here we have a general theory with several important particular cases. On the other hand, the theory gives important general results on the spectral theory of those problems.

#### Comment on Existence of Eigenvalues

This theory is difficult. Quite generally, in problems where we can have *infinitely many* eigenvalues, the existence problem becomes nontrivial, in contrast with matrix eigenvalue problems (Chap. 8), where existence is trivial, a consequence of the fact that a polynomial equation  $f(x) = 0$  ( $f$  not constant) has at least one solution and at most  $n$  numerically different ones (where  $n$  is the degree of the polynomial).

### SOLUTIONS TO PROBLEM SET 5.7, page 209

2. If  $y_m$  is a solution of (1), so is  $z_m$  because (1) is linear and homogeneous; here,  $\lambda = \lambda_m$  is the eigenvalue corresponding to  $y_m$ . Also, multiplying (2) with  $y = y_m$  by  $c$ , we see that  $z_m$  also satisfies the boundary conditions. This proves the assertion.



4.  $a = -\pi, b = \pi, c = \pi, k = 0$ .
6. Perform the differentiations in (1), divide by  $p$ , and compare; that is,

$$py'' + p'y' + (q + \lambda r)y = 0, \quad y'' + \frac{p'}{p}y' + \left(\frac{q}{p} + \lambda \frac{r}{p}\right)y = 0.$$

Hence  $f = p'/p, p = \exp(\int f dx, q/p = g, q = gp, r/p = h, r = hp$ . A reason for performing this transformation may be the discovery of the weight function needed for determining the orthogonality. We see that

$$r(x) = h(x)p(x) = h(x) \exp\left(\int f(x) dx\right).$$

8. We need

$$y = A \cos kx + B \sin kx$$

$$y' = -Ak \sin kx + Bk \cos kx$$

where  $k = \sqrt{\lambda}$ . From the first boundary condition,  $y'(0) = Bk = 0$ . With  $B = 0$  there remains

$$y' = -Ak \sin kx.$$

From this and the second boundary condition,

$$y'(\pi) = -Ak \sin \pi k = 0, \quad k\pi = m\pi, \quad k = m = 0, 1, 2, \dots.$$

Hence

$$\lambda_m = m^2, \quad m = 0, 1, \dots; \quad y_0 = 1, \quad y_m = \cos mx \quad (m = 1, 2, \dots).$$

10.  $y$  and  $y'$  as in Prob. 8. From the boundary conditions,

$$y(0) = A = y(1) = A \cos k + B \sin k$$

$$y'(0) = Bk = y'(1) = -Ak \sin k + Bk \cos k.$$

Ordering gives

$$(1 - \cos k)A - (\sin k)B = 0$$

$$(k \sin k)A + k(1 - \cos k)B = 0.$$

By eliminating  $A$  and then letting  $B \neq 0$  (to have  $y \neq 0$ , an eigenfunction) or simply by noting that for this homogeneous system to have a nontrivial solution  $A, B$ , the determinant of its coefficients must be zero; that is,

$$k(1 - \cos k)^2 + k \sin^2 k = k(2 - 2 \cos k) = 0;$$

hence  $\cos k = 1, k = 2m\pi$ , so that the eigenvalues and eigenfunctions are

$$\lambda_m = (2m\pi)^2, \quad m = 0, 1, \dots;$$

$$y_0 = 1, \quad y_m(x) = \cos(2m\pi x), \sin(2m\pi x), \quad m = 1, 2, \dots.$$

12. Use  $y$  and  $y'$  as given in Prob. 8. The first boundary condition gives

$$y(0) + y'(0) = A + Bk = 0; \quad \text{thus} \quad A = -Bk.$$

From this and the second boundary condition,

$$y(1) + y'(1) = A \cos k + B \sin k - Ak \sin k + Bk \cos k$$

$$= -Bk \cos k + B \sin k + Bk^2 \sin k + Bk \cos k = 0.$$

Canceling two terms, dividing by  $\cos k$ , and collecting the remaining terms, we obtain

$$(1 + k^2) \tan k = 0, \quad k = k_m = m\pi,$$

and the eigenvalues and eigenfunctions are

$$\lambda_m = m^2\pi^2; \quad y_0 = 1, \quad y_m = \cos m\pi x, \sin m\pi x, \quad m = 1, 2, \dots$$

14.  $x = e^t$ ,  $t = \ln|x|$  transforms the given ODE into

$$e^{-t} \frac{d}{dt} \left( e^t e^{-t} \frac{d\tilde{y}}{dt} \right) + e^{-t} \lambda \tilde{y} = 0$$

that is,

$$\frac{d^2\tilde{y}}{dt^2} + k^2\tilde{y} = 0 \quad (k^2 = \lambda).$$

For the new variable  $t$ , the boundary conditions are  $\tilde{y}(0) = 0$ ,  $\dot{\tilde{y}}(1) = 0$ . A general solution and its derivative are

$$\tilde{y} = A \cos kt + B \sin kt, \quad \dot{\tilde{y}} = -Ak \sin kt + Bk \cos kt.$$

Hence  $\tilde{y}(0) = A = 0$  and then, with  $B = 1$ ,  $\dot{\tilde{y}}(1) = k \cos k = 0$ . It follows that  $k = k_m = (2m + 1)\pi/2$ ,  $m = 0, 1, \dots$ ,  $\lambda_m = k_m^2$ , and

$$\tilde{y}_m = \sin k_m t = \sin(k_m \ln|x|), \quad m = 0, 1, \dots$$

16. A general solution  $y = e^x(A \cos kx + B \sin kx)$ ,  $k = \sqrt{\lambda}$ , of this ODE with constant coefficients is obtained as usual. The Sturm–Liouville form of the ODE is obtained by using the formulas in Prob. 6,

$$(e^{-2x}y')' + e^{-2x}(k^2 + 1)y = 0.$$

From this and the boundary conditions we expect the eigenfunctions to be orthogonal on  $0 \leq x \leq 1$  with respect to the weight function  $e^{-2x}$ . Now from that general solution and  $y(0) = A = 0$  we see that we are left with

$$y = e^x \sin kx.$$

From the second boundary condition  $y(1) = 0$  we now obtain

$$y(1) = e \sin k = 0, \quad k = m\pi, \quad m = 1, 2, \dots$$

Hence the eigenvalues and eigenfunctions are

$$\lambda_m = (m\pi)^2, \quad y_m = e^x \sin m\pi x.$$

The orthogonality is as expected (because  $e^x$  cancels).

18. From Prob. 6 we obtain the Sturm–Liouville form

$$(x^2y')' + k^2x^2y = 0 \quad k^2 = \lambda.$$

By the indicated transformation or by a CAS we obtain as a general solution

$$y = A \frac{\cos kx}{x} + B \frac{\sin kx}{x}.$$

From this and the boundary conditions we obtain

$$y(\pi) = A \frac{\cos k\pi}{k\pi} + B \frac{\sin k\pi}{k\pi} = 0$$

$$y(2\pi) = A \frac{\cos 2k\pi}{2k\pi} + B \frac{\sin 2k\pi}{2k\pi} = 0.$$

Eliminate  $A$  and divide the resulting equation by  $B$  (which must be different from zero to have  $y \neq 0$ , as is needed for an eigenfunction). Or equate the determinant of the coefficients of the two equations to zero, as a condition for obtaining a nontrivial solution  $A, B$ , not both zero; here we can drop the denominators. We obtain

$$\begin{vmatrix} \cos k\pi & \sin k\pi \\ \cos 2k\pi & \sin 2k\pi \end{vmatrix} = \cos k\pi \sin 2k\pi - \cos 2k\pi \sin k\pi.$$

By the addition formula for the sine (see App. 3.1 in the book if necessary) the right side equals  $\sin(2k\pi - k\pi) = \sin k\pi$ . This is zero for  $k\pi = m\pi$ ,  $m = 0, 1, \dots$ . Eigenvalues are  $\lambda_m = m^2$ ,  $m = 1, 2, \dots$ . Eigenfunctions are  $y_m = x^{-1} \sin mx$ ,  $m = 1, 2, \dots$ . These functions are orthogonal on  $\pi \leq x \leq 2\pi$  with respect to the weight function  $r = x^2$ .

- 20. Team Project.** (a) We integrate over  $x$  from  $-1$  to  $1$ , hence over  $\theta$  defined by  $x = \cos \theta$  from  $\pi$  to  $0$ . Using  $(1 - x^2)^{-1/2} dx = -d\theta$ , we thus obtain

$$\begin{aligned} \int_{-1}^1 \cos(m \arccos x) \cos(n \arccos x) (1 - x^2)^{-1/2} dx \\ = \int_0^\pi \cos m\theta \cos n\theta d\theta = \frac{1}{2} \int_0^\pi (\cos(m+n)\theta + \cos(m-n)\theta) d\theta, \end{aligned}$$

which is zero for integer  $m \neq n$ .

- (b) Following the hint, we calculate  $\int e^{-x} x^k L_n dx = 0$  for  $k < n$ :

$$\begin{aligned} \int_0^\infty e^{-x} x^k L_n(x) dx &= \frac{1}{n!} \int_0^\infty x^k \frac{d^n}{dx^n} (x^n e^{-x}) dx = -\frac{k}{n!} \int_0^\infty x^{k-1} \frac{d^{n-1}}{dx^{n-1}} (x^n e^{-x}) dx \\ &= \dots = (-1)^k \frac{k!}{n!} \int_0^\infty \frac{d^{n-k}}{dx^{n-k}} (x^n e^{-x}) dx = 0. \end{aligned}$$

## SECTION 5.8. Orthogonal Eigenfunction Expansions, page 210

**Purpose.** To show how families (sequences) of orthogonal functions, as they arise in eigenvalue problems and elsewhere, are used in series for representing other functions, and to show how orthogonality becomes crucial in simplifying the determination of the coefficients of such a series by integration.

### Main Content, Important Concepts

Standard notation ( $y_m, y_n$ )

Orthogonal expansion (3), eigenfunction expansion

Fourier constants (4)

Fourier series (5), Euler formulas (6)

**Short Courses.** Omit this section.

### Comment on Flexibility on Fourier Series

Since Sec. 5.8, with the definition of orthogonality taken from Sec. 5.7 and Examples 2 and 3 omitted, is independent of other sections in this chapter, it could also be used after Chap. 11 on Fourier series. We did not put it there for reasons of time and because Chap. 11 is intimately related to the main applications of Fourier series (to partial differential equations) in Chap. 12.

**Comment on Notation**

$(y_m, y_n)$  is not a must, but has become standard; perhaps if it is written out a few times, poorer students will no longer be irritated by it.

**SOLUTIONS TO PROBLEM SET 5.8, page 216**

2.  $\frac{2}{3}P_2(x) + 2P_1(x) + \frac{4}{3}P_0(x)$ . This is probably most simply obtained by the method of undetermined coefficients, beginning with the highest power,  $x^2$  and  $P_2(x)$ . The point of these problems is to make the student aware that these developments look totally different from the usual expansions in terms of powers of  $x$ .
4.  $P_0(x), P_1(x), \frac{2}{3}P_2(x) + \frac{1}{3}P_0(x), \frac{2}{5}P_3(x) + \frac{3}{5}P_1(x)$
6.  $m_0 = 5$ . The size of  $m_0$ , that is, the rapidity of convergence seems to depend on the variability of  $f(x)$ . A discontinuous derivative (e.g., as for  $|\sin x|$  occurring in connection with rectifiers) makes it virtually impossible to reach the goal. Let alone when  $f(x)$  itself is discontinuous. In the present case the series is

$$f(x) = 0.95493P_1(x) - 1.15824P_3(x) + 0.21429P_5(x) - + \cdots$$

Rounding seems to have considerable influence in all of these problems.

8.  $f(x) = -1.520P_2(x) + 0.5825P_4(x) - 0.0653P_6(x) + \cdots, m_0 = 6$
10.  $f(x) = -0.1689P_2(x) - 0.8933P_4(x) - 1.190P_6(x) + \cdots, m_0 = 12$
12.  $f(x) = 0.7470P_0(x) - 0.4458P_2(x) + 0.0765P_4(x) - \cdots, m_0 = 4$
14.  $f(x) = 0.6116P_0(x) - 0.7032P_2(x) + 0.0999P_4(x) + \cdots, m_0 = 4$
16.  $f(x) = 0.5385P_1(x) - 0.6880P_3(x) + 0.1644P_5(x) + \cdots, m_0 = 5$  or  $7$
18. **Team Project. (b)** A Maclaurin series  $f(t) = \sum_{n=0}^{\infty} a_n t^n$  has the coefficients  $a_n = f^{(n)}(0)/n!$ . We thus obtain

$$f^{(n)}(0) = \left. \frac{d^n}{dt^n} (e^{tx-t^2/2}) \right|_{t=0} = e^{x^2/2} \left. \frac{d^n}{dt^n} (e^{-(x-t)^2/2}) \right|_{t=0}$$

If we set  $x - t = z$ , this becomes

$$f^{(n)}(0) = e^{x^2/2} (-1)^n \left. \frac{d^n}{dz^n} (e^{-z^2/2}) \right|_{z=x} = (-1)^n e^{x^2/2} \frac{d^n}{dx^n} (e^{-x^2/2}) = He_n(x).$$

$$(c) G_x = \sum a_n'(x)t^n = \sum He_n'(x)t^n/n! = tG = \sum He_{n-1}(x)t^n/(n-1!), \text{ etc.}$$

(d) We write  $e^{-x^2/2} = v, v^{(n)} = d^n v/dx^n$ , etc., and use (21). By integrations by parts, for  $n > m$ ,

$$\begin{aligned} \int_{-\infty}^{\infty} v He_m He_n dx &= (-1)^n \int_{-\infty}^{\infty} He_m v^{(n)} dx = (-1)^{n-1} \int_{-\infty}^{\infty} He_m' v^{(n-1)} dx \\ &= (-1)^{n-1} m \int_{-\infty}^{\infty} He_{m-1} v^{(n-1)} dx = \cdots \\ &= (-1)^{n-m} m! \int_{-\infty}^{\infty} He_0 v^{(n-m)} dx = 0. \end{aligned}$$

(e)  $nHe_n = nxHe_{n-1} - nHe_{n-1}'$  from (22) with  $n-1$  instead of  $n$ . In this equation, the first term on the right equals  $xHe_n'$  by (21). The last term equals  $-He_n''$ , as follows by differentiation of (21).

We write  $y = Ew$ , where  $E = e^{x^2/4}$ . Then

$$\begin{aligned}y' &= \frac{1}{2}xEw + Ew' \\y'' &= \frac{1}{2}Ew + \frac{1}{4}x^2Ew + xEw' + Ew''.\end{aligned}$$

If we substitute this into the ODE (23) and divide by  $E$ , we obtain the result. The point is that the new ODE does not contain a first derivative; hence our transformation is precisely that for eliminating the first derivative from (23).

### SOLUTIONS TO CHAP. 5 REVIEW QUESTIONS AND PROBLEMS, page 217

12.  $1/(1-x)$ ,  $(1-x)^3$ . An Euler–Cauchy equation in  $t = x - 1$ .  
 14.  $x^2$ ,  $x^2 \ln x$ . An Euler–Cauchy equation with a double root.  
 16.  $x^2 \cos x$ ,  $x^2 \sin x$   
 18. We take the term  $-1 \cdot y''$  to the right and substitute the usual power series and its derivatives into the ODE. The general term on the right is  $m(m-1)a_mx^{m-2}$ . To get the same general power  $x^m$  throughout, we replace in this term  $m-2$  with  $m$ ; then the right side has the general term  $(m+2)(m+1)a_{m+2}x^m$ .

On the left we collect terms, obtaining

$$(m(m-1) - 2m + 2)a_mx^m = (m-2)(m-1)a_mx^m.$$

This gives the recursion formula

$$a_{m+2} = \frac{(m-2)(m-1)}{(m+2)(m+1)} a_m \quad (m = 0, 1, \dots)$$

$a_0$  and  $a_1$  remain arbitrary. If we set  $a_0 = 1$ ,  $a_1 = 0$ , we obtain  $a_2 = a_0 = 1$ ,  $a_3 = 0$ ,  $a_4 = 0$ , etc., and  $y_1 = 1 + x^2$ . If we set  $a_0 = 0$ ,  $a_1 = 1$ , we obtain  $y_2 = x$ . This is a basis of solutions.

To make sure that we did not make a mistake at the beginning, we could write the first few terms explicitly, namely, the constant, linear, and quadratic terms of each series and check our result. This gives

$$\begin{aligned}(2a_2x^2 + \dots) - 2a_1x - 4a_2x^2 + 2a_0 + 2a_1x + 2a_2x^2 + \dots \\= 2a_2 + 6a_3x + 12a_4x^2 + \dots\end{aligned}$$

We take  $a_0 = 1$ ,  $a_1 = 1$ . We then get  $a_2 = a_0 = 1$  from the constant terms,  $a_3 = 0$  from the linear terms,  $a_4 = 0$  from the quadratic terms, etc., as before.

20. Indicial equation  $r(r-1) + r - 1 = 0$ . Hence  $r_1 = 1$ ,  $r_2 = -1$ . These roots differ by an integer; this is Case 3. It turns out that no logarithm will appear. A basis of solutions is

$$\begin{aligned}y_1 &= x - \frac{x^5}{3!} + \frac{x^9}{5!} - \frac{x^{13}}{7!} + \dots \\y_2 &= \frac{1}{x} - \frac{x^3}{2!} + \frac{x^7}{4!} - \frac{x^{11}}{6!} + \frac{x^{15}}{8!} - \dots\end{aligned}$$

We see that  $y_1 = x^{-1} \sin x^2$  and  $y_2 = x^{-1} \cos x^2$ . The coefficients  $a_0, \dots, a_3$  and  $A_0, \dots, A_3$  were arbitrary, and the two solutions were obtained by the choices  $a_0 = 1$  and the others zero, and  $A_0 = 1$  and the other  $A_j$  ( $j = 1, 2, 3$ ) zero.

22.  $y = x^{-2}[c_1J_4(x) + c_2Y_4(x)]$

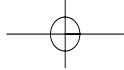

24.  $y = x^{5/2}(c_1 \cos x + c_2 \sin x)$ . This is the case in which the Bessel functions reduce to cosine and sine divided or multiplied by a power of  $x$ .

26.  $y = A \cos kx + B \sin kx$ , where  $k = \sqrt{\lambda}$ .  $y(0) = A = 0$  from the first boundary condition. From this and the second boundary condition,

$$y = B \sin kx, \quad y' = Bk \cos kx, \quad \cos k\pi = 0, \quad k\pi = (2m + 1)\pi/2.$$

Hence  $k_m = (2m + 1)/2$ ,  $\lambda = k_m^2$ ,  $y_m = \sin k_m x$ ,  $m = 0, 1, \dots$ .

28.  $x = e^t$ ,  $t = \ln |x|$ ,  $y(x) \equiv \tilde{y}(t)$ ,  $y' = \tilde{y}'/x$ ,  $\tilde{y}'' + \lambda\tilde{y} = 0$ . For  $t$  the boundary conditions are  $\tilde{y}(0) = 0$ ,  $\tilde{y}(1) = 0$ . A general solution is  $\tilde{y} = A \cos kt + B \sin kt$ ,  $k = \sqrt{\lambda}$ . Now  $A = 0$  from the first boundary condition, and  $k = k_m = m\pi$  from the second. Hence the eigenvalues are  $\lambda_m = (m\pi)^2$  and eigenfunctions are  $y_m = \sin m\pi t = \sin(m\pi \ln |x|)$ ,  $m = 1, 2, \dots$ .

30.  $y = A \cos kx + B \sin kx$ ,  $y' = -Ak \sin kx + Bk \cos kx$ . From the first boundary condition,  $A + Bk = 0$ ; hence  $A = -Bk$ . From the second boundary condition, with  $A$  replaced by  $-Bk$ ,

$$-Bk \cos 2k\pi + B \sin 2k\pi = 0, \quad k = \tan 2k\pi, \quad \lambda_m = k_m^2$$

where the  $k_m$ 's are the infinitely many solutions of  $k = \tan 2k\pi$ . Eigenfunctions:

$$y_m = \cos k_m x, \quad \sin k_m x.$$

32.  $0.505P_0(x) + 0.377P_2(x) - 0.920P_4(x) + \dots$

34.  $0.637P_0(x) + 0.154P_2(x) + 0.672P_4(x) - 0.663P_6(x) + \dots$ . The approximation by partial sums is poor near the points of discontinuity of the derivative. This is typical.

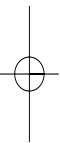

## CHAPTER 6 Laplace Transform

### Major Changes

This chapter underwent some major changes regarding the order of the material and the emphasis placed on the various topics.

In particular, Dirac's delta was placed in a separate section. Partial fractions are now considered earlier. Their importance in this chapter has been diminished, and they are explained in terms of practical problems when they are needed, rather than in terms of impractical theoretical formulas. Convolution and nonhomogeneous linear ODEs are now considered earlier, whereas differentiation and integration of *transforms* (not of *functions*!) appears later and in a lesser role.

### SECTION 6.1. Laplace Transform. Inverse Transform. Linearity. *s*-Shifting, page 221

**Purpose.** To explain the basic concepts, to present a short list of basic transforms, and to show how these are derived from the definition.

#### Main Content, Important Concepts

Transform, inverse transform, linearity

First shifting theorem

Table 6.1

Existence and its practical significance

#### Comment on Table 6.1

After working for a while in this chapter, the student should be able to memorize these transforms. Further transforms in Sec. 6.9 are derived as we go along, many of them from Table 6.1.

### SOLUTIONS TO PROBLEM SET 6.1, page 226

$$2. (t^2 - 3)^2 = t^4 - 6t^2 + 9; \text{ transform } \frac{24}{s^5} - \frac{12}{s^3} + \frac{9}{s}$$

$$4. \sin^2 4t = \frac{1}{2} - \frac{1}{2} \cos 8t; \text{ transform } \frac{1}{2s} - \frac{s}{2(s^2 + 64)} = \frac{32}{s(s^2 + 64)}$$

$$6. e^{-t} \sinh 5t = \frac{1}{2} (e^{4t} - e^{-6t}); \text{ transform } \frac{1}{2} \left( \frac{1}{s-4} - \frac{1}{s+6} \right) = \frac{5}{(s+1)^2 - 25}.$$

This can be checked by the first shifting theorem.

$$8. \sin(3t - \frac{1}{2}) = \cos \frac{1}{2} \sin 3t - \sin \frac{1}{2} \cos 3t; \text{ transform}$$

$$\frac{3 \cos \frac{1}{2} - s \sin \frac{1}{2}}{s^2 + 9}$$

$$10. \frac{-1.6}{s^2 + 0.04}$$

$$12. (t+1)^3 = t^3 + 3t^2 + 3t + 1; \text{ transform } \frac{6}{s^4} + \frac{6}{s^3} + \frac{3}{s^2} + \frac{1}{s}$$

$$14. k \int_a^b e^{-st} dt = \frac{k}{s} (e^{-as} - e^{-bs})$$

16.  $k(1 - t/b)$ ; transform

$$\begin{aligned} k \int_0^b e^{-st} \left(1 - \frac{t}{b}\right) dt &= -\frac{k}{s} e^{-st} \left(1 - \frac{t}{b}\right) \Big|_0^b + \frac{k}{s} \int_0^b \left(-\frac{1}{b}\right) e^{-st} dt \\ &= \frac{k}{bs^2} (bs + e^{-bs} - 1) \end{aligned}$$

$$18. \frac{k}{b} \int_0^b e^{-st} t dt = \frac{k}{b} \left( \frac{1 - e^{-bs}}{s^2} - \frac{be^{-bs}}{s} \right)$$

20.  $\int_0^1 e^{-st} t dt + \int_1^2 e^{-st} (2 - t) dt$ . Integration by parts gives

$$\begin{aligned} & -\frac{e^{-st} t}{s} \Big|_0^1 + \frac{1}{s} \int_0^1 e^{-st} dt - \frac{e^{-st} (2 - t)}{s} \Big|_1^2 - \frac{1}{s} \int_1^2 e^{-st} dt \\ &= -\frac{e^{-s}}{s} - \frac{1}{s^2} (e^{-s} - 1) + \frac{e^{-s}}{s} + \frac{1}{s^2} (e^{-2s} - e^{-s}) \\ &= \frac{1}{s^2} (-e^{-s} + 1 + e^{-2s} - e^{-s}) = \frac{(1 - e^{-s})^2}{s^2}. \end{aligned}$$

22. Let  $st = \tau$ ,  $t = \tau/s$ ,  $dt = d\tau/s$ . Then

$$\begin{aligned} \mathcal{L}(1/\sqrt{t}) &= \int_0^\infty e^{-st} t^{-1/2} dt \\ &= \int_0^\infty e^{-\tau} (\tau/s)^{-1/2} \frac{1}{s} d\tau \\ &= s^{-1/2} \int_0^\infty e^{-\tau} \tau^{-1/2} d\tau \\ &= s^{-1/2} \Gamma\left(\frac{1}{2}\right) = \sqrt{\pi/s}. \end{aligned}$$

24. No matter how large we choose  $M$  and  $k$ , we have  $e^{t^2} > Me^{kt}$  for all  $t$  greater than some  $t_0$  because  $t^2 > \ln M + kt$  for all sufficiently large  $t$  (and fixed positive  $M$  and  $k$ ).

26. Use  $e^{at} = \cosh at + \sinh at$ .

28. Let  $f = \mathcal{L}^{-1}(F)$ ,  $g = \mathcal{L}^{-1}(G)$ . Since the transform is linear, we obtain

$$aF + bG = a\mathcal{L}(f) + b\mathcal{L}(g) = \mathcal{L}(af + bg).$$

Now apply  $\mathcal{L}^{-1}$  on both sides to get the desired result,

$$\mathcal{L}^{-1}(aF + bG) = \mathcal{L}^{-1}\mathcal{L}(af + bg) = af + bg = a\mathcal{L}^{-1}(F) + b\mathcal{L}^{-1}(G).$$

Note that we have proved much more than just the claim, namely, the following.

**Theorem.** *If a linear transformation has an inverse, the inverse is linear.*

30.  $2 \cosh 4t + 4 \sinh 4t = 3e^{4t} - e^{-4t}$

$$32. \frac{10}{2s + \sqrt{2}} = \frac{5}{s + 1/\sqrt{2}}. \quad \text{Answer } 5e^{-t/\sqrt{2}}$$



$$34. \frac{20}{(s-1)(s+4)} = 4 \left( \frac{1}{s-1} - \frac{1}{s+4} \right). \text{ Answer } 4(e^t - e^{-4t})$$

$$36. 4e^{-t} + 9e^{-4t} + 16e^{-9t} + 25e^{-16t}$$

$$38. \frac{18s-12}{9s^2-1} = \frac{2s-4/3}{s^2-1/9}. \text{ Answer } 2 \cosh \frac{1}{3}t - 4 \sinh \frac{1}{3}t$$

40. If  $a \neq b$ , then  $\frac{1}{b-a}(e^{-at} - e^{-bt})$ . If  $a = b$ , then  $te^{-bt}$  by the shifting theorem (or from the first result by l'Hôpital's rule, taking derivatives with respect to  $a$ ).

$$42. \frac{-72}{(s+0.5)^5}$$

$$44. \frac{s+3}{(s+3)^2 + \pi^2}$$

$$46. a_0/(s+1) + a_1/(s+1)^2 + \cdots + n!a_n/(s+1)^{n+1}$$

$$48. \pi te^{-\pi t}$$

$$50. e^t(\cos 2t - \frac{5}{2} \sin 2t)$$

$$52. e^{3t}(4 \cos 3t + \frac{10}{3} \sin 3t)$$

$$54. \frac{2s-56}{s^2-4s-12} = \frac{2(s-2)-52}{(s-2)^2-16}. \text{ Answer}$$

$$e^{2t}(2 \cosh 4t - 13 \sinh 4t) = -\frac{11}{2}e^{6t} + \frac{15}{2}e^{-2t}$$

## SECTION 6.2. Transforms of Derivatives and Integrals. ODEs, page 227

**Purpose.** To get a first impression of how the Laplace transform solves ODEs and initial value problems, the task for which it is designed.

### Main Content, Important Concepts

$$(1) \mathcal{L}(f') = s\mathcal{L}(f) - f(0)$$

Extension of (1) to higher derivatives [(2), (3)]

Solution of an ODE, subsidiary equation

Transform of the integral of a function (Theorem 3)

Transfer function (6)

Shifted data problems (Example 6)

### Comment on ODEs

The last of the three steps of solution is the hardest, but we shall derive many general properties of the Laplace transform (collected in Sec. 6.8) that will help, along with formulas in Table 6.1 and those in Sec. 6.9, so that we can proceed to ODEs for which the present method is superior to the classical one.

## SOLUTIONS TO PROBLEM SET 6.2, page 232

**Purpose of Probs. 1–8.** 1. To familiarize students with (1) and (2) before they apply these formulas to ODEs. 2. Students should become aware that transforms can often be obtained by several methods.

2.  $f = t \cos 5t$ ,  $f' = \cos 5t - 5t \sin 5t$ ,  $f'' = -10 \sin 5t - 25t \cos 5t$ . Hence

$$\mathcal{L}(f'') = \frac{-50}{s^2 + 25} - 25\mathcal{L}(f) = s^2\mathcal{L}(f) - s \cdot 0 - 1$$

and thus

$$(s^2 + 25)\mathcal{L}(f) = \frac{-50}{s^2 + 25} + 1 = \frac{s^2 - 25}{s^2 + 25}.$$

Answer

$$\mathcal{L}(f) = \frac{s^2 - 25}{(s^2 + 25)^2}.$$

4.  $f = \cos^2 \pi t$ ,  $f' = -2\pi \cos \pi t \sin \pi t = -\pi \sin 2\pi t$ . Hence

$$\mathcal{L}(f') = \frac{-2\pi^2}{s^2 + 4\pi^2} = s\mathcal{L}(f) - 1, \quad s\mathcal{L}(f) = \frac{s^2 + 4\pi^2 - 2\pi^2}{s^2 + 4\pi^2}.$$

This gives the answer

$$\mathcal{L}(f) = \frac{s^2 + 2\pi^2}{s(s^2 + 4\pi^2)}.$$

6.  $f = \cosh^2 \frac{1}{2}t$ ,  $f' = \cosh \frac{1}{2}t \sinh \frac{1}{2}t = \frac{1}{2} \sinh t$ . Hence

$$\mathcal{L}(f') = s\mathcal{L}(f) - 1 = \frac{1/2}{s^2 - 1}, \quad s\mathcal{L}(f) = \frac{\frac{1}{2} + s^2 - 1}{s^2 - 1}.$$

This gives the answer

$$\mathcal{L}(f) = \frac{s^2 - \frac{1}{2}}{s(s^2 - 1)}.$$

8.  $f = \sin^4 t$ ,  $f' = 4 \sin^3 t \cos t$ ,  $f'' = 12 \sin^2 t \cos^2 t - 4 \sin^4 t$ . From this and (2) it follows that

$$\mathcal{L}(f'') = 12\mathcal{L}(\sin^2 t \cos^2 t) - 4\mathcal{L}(f) = s^2\mathcal{L}(f).$$

Collecting terms and using Prob. 3 with  $\omega = 2$  and  $\sin 2\alpha = 2 \sin \alpha \cos \alpha$ , we obtain

$$(s^2 + 4)\mathcal{L}(f) = 3\mathcal{L}(\sin^2 2t) = \frac{3 \cdot 8}{s(s^2 + 16)}.$$

Answer

$$\mathcal{L}(f) = \frac{24}{s(s^2 + 4)(s^2 + 16)}.$$

10.  $sY - 2.8 + 4Y = 0$ ,  $(s + 4)Y = 2.8$ ,  $Y = 2.8/(s + 4)$ ,  $y = 2.8e^{-4t}$   
 12.  $(s^2 - s - 6)Y = (s - 3)(s + 2)Y = 6s + 13 - 6 = 6s + 7$ . Hence

$$Y = \frac{6s + 7}{(s - 3)(s + 2)} = \frac{5}{s - 3} + \frac{1}{s + 2}$$

and

$$y = 5e^{3t} + e^{-2t}.$$

14.  $(s - 2)^2 Y = 2.1s + 3.9 - 4 \cdot 2.1$ . Hence

$$Y = \frac{2.1s - 4.5}{(s - 2)^2} = \frac{2.1(s - 2) + 4.2 - 4.5}{(s - 2)^2}.$$

This gives the solution

$$y = 2.1e^{2t} - 0.3te^{2t}$$

as expected in the case of a double root of the characteristic equation.

16.  $(s^2 + ks - 2k^2)Y = 2s + 2k + 2k$ ,  $Y = (2s + 4k)/[(s - k)(s + 2k)] = 2/(s - k)$ ,  
 $y = 2e^{kt}$

18. We obtain

$$(s^2 + 9)Y = \frac{10}{s + 1}.$$

The solution of this subsidiary equation is

$$Y = \frac{10}{(s + 1)(s^2 + 9)} = \frac{1}{s + 1} - \frac{s - 1}{s^2 + 9}.$$

This gives the solution  $y = e^{-t} - \cos 3t + \frac{1}{3} \sin 3t$ .

20. The subsidiary equation is

$$(s^2 - 6s + 5)Y = 3.2s + 6.2 - 6 \cdot 3.2 + 29s/(s^2 + 4).$$

The solution  $Y$  is

$$Y = \frac{(3.2s - 13)(s^2 + 4) + 29s}{(s - 1)(s - 5)(s^2 + 4)}.$$

In terms of partial fractions, this becomes

$$Y = \frac{1}{s - 1} + \frac{2}{s - 5} + \frac{0.2s - 2.4 \cdot 2}{s^2 + 4}.$$

The inverse transform of this gives the solution

$$y = e^t + 2e^{5t} + 0.2 \cos 2t - 2.4 \sin 2t.$$

22.  $t = \tilde{t} + 1$ , so that the “shifted problem” is

$$\tilde{y}'' - 2\tilde{y}' - 3\tilde{y} = 0, \quad \tilde{y}(0) = -3, \quad \tilde{y}'(0) = -17.$$

Hence the corresponding subsidiary equation is

$$(s^2 - 2s - 3)\tilde{Y} = -3s - 17 + 6.$$

Its solution is

$$\tilde{Y} = \frac{-3s - 11}{(s + 1)(s - 3)} = \frac{2}{s + 1} - \frac{5}{s - 3}.$$

Inversion gives

$$\tilde{y} = 2e^{-\tilde{t}} - 5e^{3\tilde{t}}.$$

This is the solution of the “shifted problem,” and the solution of the given problem is

$$y = 2e^{-(t-1)} - 5e^{3(t-1)}.$$

24.  $t = \tilde{t} + 3$ , so that the “shifted equation” is

$$\tilde{y}'' + 2\tilde{y}' + 5\tilde{y} = 50\tilde{t}.$$

The corresponding subsidiary equation is

$$[(s + 1)^2 + 4]\tilde{Y} = -4s + 14 - 2 \cdot 4 + 50/s^2.$$

Its solution is

$$\tilde{Y} = \frac{10}{s^2} - \frac{4}{s} + \frac{4}{(s+1)^2 + 4}.$$

The inverse transform is

$$\tilde{y} = 10\tilde{t} - 4 + 2e^{-\tilde{t}} \sin 2\tilde{t}.$$

Hence the given problem has the solution

$$y = 10(t-3) - 4 + 2e^{-(t-3)} \sin 2(t-3).$$

**26. Project.** We derive (a). We have  $f(0) = 0$  and

$$f'(t) = \cos \omega t - \omega t \sin \omega t, \quad f'(0) = 1$$

$$f''(t) = -2\omega \sin \omega t - \omega^2 f(t).$$

By (2),

$$\mathcal{L}(f'') = -2\omega \frac{\omega}{s^2 + \omega^2} - \omega^2 \mathcal{L}(f) = s^2 \mathcal{L}(f) - 1.$$

Collecting  $\mathcal{L}(f)$ -terms, we obtain

$$\mathcal{L}(f)(s^2 + \omega^2) = \frac{-2\omega^2}{s^2 + \omega^2} + 1 = \frac{s^2 - \omega^2}{s^2 + \omega^2}.$$

Division by  $s^2 + \omega^2$  on both sides gives (a).

In (b) on the right we get from (a)

$$\mathcal{L}(\sin \omega t - \omega t \cos \omega t) = \frac{\omega}{s^2 + \omega^2} - \omega \frac{s^2 - \omega^2}{(s^2 + \omega^2)^2}.$$

Taking the common denominator and simplifying the numerator,

$$\omega(s^2 + \omega^2) - \omega(s^2 - \omega^2) = 2\omega^3$$

we get (b).

(c) is shown in Example 1.

(d) is derived the same way as (b), with + instead of -, so that the numerator is

$$\omega(s^2 + \omega^2) + \omega(s^2 - \omega^2) = 2\omega s^2,$$

which gives (d).

(e) is similar to (a). We have  $f(0) = 0$  and obtain

$$f'(t) = \cosh at + at \sinh at, \quad f'(0) = 1$$

$$f''(t) = 2a \sinh at + a^2 f(t).$$

By (2) we obtain

$$\mathcal{L}(f'') = \frac{2a^2}{s^2 - a^2} + a^2 \mathcal{L}(f) = s^2 \mathcal{L}(f) - 1.$$

Hence

$$\mathcal{L}(f)(s^2 - a^2) = \frac{2a^2}{s^2 - a^2} + 1 = \frac{s^2 + a^2}{s^2 - a^2}.$$

Division by  $s^2 - a^2$  gives (e).

(f) follows similarly. We have  $f(0) = 0$  and, furthermore,

$$f'(t) = \sinh at + at \cosh at, \quad f'(0) = 0$$

$$f''(t) = 2a \cosh at + a^2 f(t)$$

$$\mathcal{L}(f''(t)) = 2a \frac{s}{s^2 - a^2} + a^2 \mathcal{L}(f) = s^2 \mathcal{L}(f)$$

$$\mathcal{L}(f)(s^2 - a^2) = \frac{2as}{s^2 - a^2}.$$

Division by  $s^2 - a^2$  gives formula (f).

28. We start from

$$\mathcal{L}^{-1} \left( \frac{1}{s - \pi} \right) = e^{\pi t}$$

and integrate twice. The first integration gives

$$\frac{1}{\pi} (e^{\pi t} - 1).$$

Multiplication by 10 and another integration from 0 to  $t$  gives the *answer*

$$\frac{10}{\pi^2} (e^{\pi t} - 1) - \frac{10t}{\pi}.$$

30. The inverse of  $1/(s^2 + 1)$  is  $\sin t$ . A first integration from 0 to  $t$  gives  $1 - \cos t$ , and another integration yields  $t - \sin t$ .

32. The inverse of  $2/(s^2 + 9)$  is  $\frac{2}{3} \sin 3t$ . Integration from 0 to  $t$  gives the *answer*

$$\frac{2}{9} (1 - \cos 3t) = \frac{4}{9} \sin^2 \frac{3}{2}t.$$

34. The inverse of  $1/(s^2 + \pi^2)$  is  $\frac{1}{\pi} \sin \pi t$ . A first integration from 0 to  $t$  gives

$$\frac{1}{\pi^2} (1 - \cos \pi t).$$

Another integration gives the *answer*

$$\frac{1}{\pi^2} \left( t - \frac{1}{\pi} \sin \pi t \right).$$

### SECTION 6.3. Unit Step Function. $t$ -Shifting, page 233

#### Purpose

1. To introduce the unit step function  $u(t - a)$ , which together with Dirac's delta (Sec. 6.4) greatly increases the usefulness of the Laplace transform.
2. To find the transform of

$$0 \quad (t < a), \quad f(t - a) \quad (t > a)$$

if that of  $f(t)$  is known (" $t$ -shifting"). (" $s$ -shifting" was considered in Sec. 6.1.)

**Main Content, Important Concepts**

Unit step function (1), its transform (2)

Second shifting theorem (Theorem 1)

**Comment on the Unit Step Function**

Problem Set 6.3 shows that  $u(t - a)$  is the basic function for representing discontinuous functions.

**SOLUTIONS TO PROBLEM SET 6.3, page 240**

2.  $t(1 - u(t - 1)) = t - [(t - 1) + 1]u(t - 1)$ . Hence the transform is

$$\frac{1}{s^2} - \frac{e^{-s}}{s^2} - \frac{e^{-s}}{s}.$$

4.  $(\sin 3t)(1 - u(t - \pi)) = \sin 3t + u(t - \pi) \sin 3(t - \pi)$ . Hence the transform is

$$\frac{3}{s^2 + 9} (1 + e^{-\pi s}).$$

6. We obtain

$$t^2 u(t - 3) = [(t - 3)^2 + 6(t - 3) + 9]u(t - 3).$$

Hence the transform is

$$\left( \frac{2}{s^3} + \frac{6}{s^2} + \frac{9}{s} \right) e^{-3s}.$$

8.  $(1 - e^{-t})(1 - u(t - \pi)) = 1 - e^{-t} - (1 - e^{-(t-\pi)-\pi})u(t - \pi)$ . Hence the transform is

$$\frac{1}{s} - \frac{1}{s+1} - \frac{e^{-\pi s}}{s} + e^{-\pi} \frac{1}{s+1} e^{-\pi s}.$$

10.  $u(t - 6\pi/\omega) \sin \omega t = u(t - 6\pi/\omega) \sin(\omega t - 6\pi)$ . Hence the transform is

$$\frac{\omega}{s^2 + \omega^2} e^{-6\pi s/\omega}.$$

12.  $\frac{1}{2}(e^t - e^{-t})(1 - u(t - 2)) = \frac{1}{2}(e^t - e^{-t}) - \frac{1}{2}(e^{(t-2)+2} - e^{-(t+2)-2})u(t - 2)$ . Hence the transform is

$$\frac{1}{2} \cdot \frac{1}{s-1} - \frac{1}{2} \cdot \frac{1}{s+1} - \frac{1}{2} \left( \frac{e^2}{s-1} - \frac{e^{-2}}{s+1} \right) e^{-2s}.$$

Alternatively, by using the addition formula (22) in App. 3.1 we obtain the transform in the form

$$\frac{1}{s^2 - 1} - \left( \frac{\cosh 2}{s^2 - 1} + \frac{s \sinh 2}{s^2 - 1} \right) e^{-2s}.$$

14.  $s/(s^2 + \omega^2)$  has the inverse  $\cos \omega t$ . Hence  $f(t) = 0$  if  $t < 1$  and  $\cos \omega(t - 1)$  if  $t > 1$ .

16.  $t - [(t - 1) + 1]u(t - 1) = t - t u(t - 1)$ ; hence  $f(t) = t$  if  $0 < t < 1$  and 0 if  $t > 1$ .

18.  $1/(s^2 + 2s + 2) = 1/[(s + 1)^2 + 1]$  has the inverse  $e^{-t} \sin t$ . Hence the given transform has the inverse

$$e^{-(t-\pi)} \sin(t - \pi) u(t - \pi) = -e^{\pi-t} \sin t u(t - \pi)$$

which is 0 if  $t < \pi$  and  $-e^{\pi-t} \sin t$  if  $t > \pi$ .

20. The inverse transform is

$$e^{kt} - e^{k(t-1)}e^k u(t-1) = \begin{cases} e^{kt} & \text{if } 0 < t < 1 \\ 0 & \text{if } t > 1. \end{cases}$$

22. The inverse transform is  $2.5(u(t-2.6) - u(t-3.8))$ , that is, 2.5 if  $2.6 < t < 3.8$  and 0 elsewhere.

24.  $(9s^2 - 6s + 1)Y = 27s + 9 - 18 = 27s - 9$ . Hence

$$Y = \frac{27s - 9}{9s^2 - 6s + 1} = \frac{3s - 1}{(s - \frac{1}{3})^2} = \frac{3}{s - \frac{1}{3}}.$$

Hence the *answer* is  $y = 3e^{t/3}$ .

26.  $(s^2 + 10s + 24)Y = (s + 4)(s + 6)Y = \frac{288}{s^3} + \frac{19}{12}s - 5 + \frac{190}{12}$ . Division by

$s^2 + 10s + 24$  and expansion in terms of partial fractions gives

$$Y = \frac{12}{s^3} - \frac{5}{s^2} + \frac{19/12}{s}.$$

Hence the *answer* is  $y = 6t^2 - 5t + \frac{19}{12}$ . Note that it does not contain a contribution from the general solution of the homogeneous ODE.

28. The subsidiary equation is

$$(s^2 + 3s + 2)Y = \frac{1}{s} - \frac{e^{-s}}{s}.$$

It has the solution

$$Y = \frac{1 - e^{-s}}{s(s^2 + 3s + 2)} = \left( \frac{1}{2s} + \frac{1}{2(s+2)} - \frac{1}{s+1} \right) (1 - e^{-s}).$$

This gives the *answer*

$$y = \frac{1}{2} + \frac{1}{2}e^{-2t} - e^{-t} - \left( \frac{1}{2} + \frac{1}{2}e^{-2(t-1)} - e^{-(t-1)} \right) u(t-1);$$

that is,

$$y = \begin{cases} \frac{1}{2} + \frac{1}{2}e^{-2t} - e^{-t} & \text{if } 0 < t < 1 \\ \frac{1}{2}e^{-2t}(1 - e^2) - e^{-t}(1 - e) & \text{if } t > 1. \end{cases}$$

30. The subsidiary equation is

$$(s^2 - 16)Y = \frac{48}{s-2} (1 - e^{-4s+8}) + 3s - 4.$$

Now

$$\frac{\frac{48}{s-2} + 3s - 4}{s^2 - 16} = \frac{3}{s+4} + \frac{4}{s-4} - \frac{4}{s-2}$$

has the inverse transform  $y_1 = 3e^{-4t} + 4e^{4t} - 4e^{2t}$ . This is the solution for  $0 < t < 4$ . The solution for  $t > 4$  is

$$y = y_2 = e^{-4t}(3 - e^{24}) + e^{4t}(4 - 3e^{-8}).$$

In  $y_2$  the  $e^{2t}$ -term has dropped out. The result can be confirmed classically by noting that we must have

$$\begin{aligned}y_2(4) &= y_1(4) = 3e^{-16} + 4e^{16} - 4e^8 \\y_2'(4) &= y_1'(4) = -12e^{-16} + 16e^{16} - 8e^8.\end{aligned}$$

32.  $r = 35e^{2t}(1 - u(t - 2))$ . The subsidiary equation is

$$(s^2 + 8s + 15)Y = \frac{35}{s - 2} (1 - e^{-2(s-2)}) + 3s - 8 + 24.$$

Its solution is

$$Y = \frac{3s^2 + 10s + 3 - 35e^{-2s+4}}{s^3 + 6s^2 - s - 30}.$$

The inverse transform of  $Y$  is

$$y = e^{2t} + 2e^{-5t} + u(t - 2)(-e^{2t} - \frac{5}{2}e^{-5t+14} + \frac{7}{2}e^{-3t+10}).$$

Thus,

$$y = \begin{cases} e^{2t} + 2e^{-5t} & \text{if } 0 < t < 2 \\ e^{-5t}(2 - \frac{5}{2}e^{14}) + \frac{7}{2}e^{-3t+10} & \text{if } t > 2. \end{cases}$$

34.  $t = \pi + \tilde{t}$ ,  $\tilde{y}'' + 2\tilde{y}' + 5\tilde{y} = \tilde{r}$ ,  $\tilde{r} = 10[-1 + u(\tilde{t} - \pi)] \sin \tilde{t}$ ,  $\tilde{y}(0) = 1$ ,  $\tilde{y}'(0) = -2 + 2e^{-\pi}$ . The solution in terms of  $\tilde{t}$  is

$$\begin{aligned}\tilde{y}(\tilde{t}) &= e^{-\tilde{t}-\pi} \sin 2\tilde{t} + \cos \tilde{t} - 2 \sin \tilde{t} \\ &\quad + u(\tilde{t} - \pi)[e^{-\tilde{t}+\pi}(-\cos 2\tilde{t} + \frac{1}{2} \sin 2\tilde{t}) - \cos \tilde{t} + 2 \sin \tilde{t}].\end{aligned}$$

In terms of  $t$ ,

$$\begin{aligned}y(t) &= e^{-t} \sin 2t - \cos t + 2 \sin t \\ &\quad + u(t - 2\pi)[e^{-t+2\pi}(-\cos 2t + \frac{1}{2} \sin 2t) + \cos t - 2 \sin t].\end{aligned}$$

36.  $10i + 100 \int_0^t i(\tau) d\tau = 100(u(t - 0.5) - u(t - 0.6))$ . Divide by 10 and take the transform, using Theorem 3 in Sec. 6.2,

$$I + \frac{10}{s} I = \frac{10}{s} (e^{-0.5s} - e^{-0.6s}).$$

Solving for  $I = \mathcal{L}(i)$  gives

$$I = \frac{10}{s + 10} (e^{-0.5s} - e^{-0.6s}).$$

The inverse transform is

$$i(t) = 10(e^{-10(t-0.5)} u(t - 0.5) - e^{-10(t-0.6)} u(t - 0.6)).$$

Hence

$$\begin{aligned}i(t) &= 0 && \text{if } t < 0.5 \\ i(t) &= 10e^{-10(t-0.5)} && \text{if } 0.5 < t < 0.6 \\ i(t) &= 10(e^{-10(t-0.5)} - e^{-10(t-0.6)}) \\ &= 10e^{-10t}(e^5 - e^6) \\ &= -2550e^{-10t} && \text{if } t > 0.6.\end{aligned}$$



Jumps occur at  $t = 0.5$  (upward) and at  $t = 0.6$  (downward) because the right side has those jumps and the term involving the integral (representing the charge on the capacitor) cannot change abruptly; hence the first term,  $Ri(t)$ , must jump by the amounts of the jumps on the right, which have size 100, and since  $R = 10$ , the current has jumps of size 10.

38. We obtain

$$I = 14 \cdot 10^5 \frac{se^{-4s-12}}{(s+10)(s+3)} = \left( \frac{2 \cdot 10^6}{s+10} - \frac{6 \cdot 10^5}{s+3} \right) e^{-4s-12}$$

hence

$$i = u(t-4) [2 \cdot 10^6 e^{-10(t-4)-12} - 6 \cdot 10^5 e^{-3(t-4)-12}].$$

40.  $i' + 1000i = 40 \sin t u(t - \pi)$ . The subsidiary equation is

$$sI + 1000I = -40 \frac{e^{-\pi s}}{s^2 + 1}.$$

Its solution is

$$I = \frac{-40e^{-\pi s}}{(s^2 + 1)(s + 1000)} = \frac{-40e^{-\pi s}}{1\,000\,001} \left( \frac{1}{s + 1000} - \frac{s - 1000}{s^2 + 1} \right).$$

The inverse transform is

$$i = u(t - \pi) \left[ -\frac{40}{1\,000\,001} (\cos t + e^{-1000(t-\pi)}) + \frac{40\,000}{1\,000\,001} \sin t \right];$$

hence  $i = 0$  if  $t < \pi$ , and  $i \approx 0.04 \sin t$  if  $t > \pi$ .

42.  $i'' + 4i = 200(1 - t^2)(1 - u(t - 1))$ . Observing that

$$t^2 = (t - 1)^2 + 2(t - 1) + 1,$$

we obtain the subsidiary equation

$$(s^2 + 4)I = 200 \left( \frac{1}{s} - \frac{2}{s^3} \right) + 200e^{-s} \left( \frac{2}{s^2} + \frac{2}{s^3} \right).$$

Its solution is

$$I = 200 \frac{s^2 - 2 + e^{-s}(2s + 2)}{s^3(s^2 + 4)} = 25 \left( \frac{3}{s} - \frac{4}{s^3} - \frac{3s}{s^2 + 4} \right) + 25e^{-s} \left( -\frac{1}{s} + \frac{4}{s^2} + \frac{4}{s^3} + \frac{s - 4}{s^2 + 4} \right).$$

Its inverse transform is

$$i = 75 - 50t^2 - 75 \cos 2t + u(t - 1)[-75 + 50t^2 + 25 \cos(2t - 2) - 50 \sin(2t - 2)].$$

44.  $0.5i'' + 20i = 78 \cos t (1 - u(t - \pi))$ . The subsidiary equation is

$$(0.5s^2 + 20)I = \frac{78s}{s^2 + 1} (1 + e^{-\pi s}).$$

Its solution is

$$I = \frac{156s(1 + e^{-\pi s})}{(s^2 + 1)(s^2 + 40)} = 4s \left( \frac{1}{s^2 + 1} - \frac{1}{s^2 + 40} \right) (1 + e^{-\pi s}).$$

Its inverse transform is

$$i = 4 \cos t - 4 \cos \sqrt{40}t - 4u(t - \pi) [\cos t + \cos(\sqrt{40}(t - \pi))].$$

46.  $i' + 4i + 20 \int_0^t i(\tau) d\tau = 34e^{-t}(1 - u(t - 4))$ . The subsidiary equation is

$$\left(s + 4 + \frac{20}{s}\right)I = \frac{34}{s + 1}(1 - e^{-4s-4}).$$

Its solution is

$$I = \frac{34s}{(s + 1)(s^2 + 4s + 20)}(1 - e^{-4s-4}).$$

The inverse transform is

$$i = -2e^{-t} + e^{-2t}(2 \cos 4t + 9 \sin 4t) + u(t - 4) [2e^{-t+4} + e^{-2(t-2)}(2e^{-t} - 2 \cos 4(t - 4) - 9 \sin 4(t - 4))].$$

### SECTION 6.4. Short Impulses. Dirac's Delta Function. Partial Fractions, page 241

**Purpose.** Modeling of short impulses by **Dirac's delta** function (also known as **unit impulse** function). The text includes a remark that this is not a function in the usual sense of calculus but a "generalized function" or "distribution." Details cannot be discussed on the level of this book; they can be found in books on functional analysis or on PDEs. See, e.g., L. Schwartz, *Mathematics for the Physical Sciences*, Paris: Hermann, 1966. The French mathematician LAURENT SCHWARTZ (1915–2002) created and popularized the theory of distributions. See also footnote 2.

#### Main Content

- Definition of Dirac's delta (3)
- Sifting property (4)
- Transform of delta (5)
- Application to mass–spring systems and electric networks
- More on partial fractions (Example 4)

For the beginning of the discussion of partial fractions in the present context, see Sec. 6.2.

### SOLUTIONS TO PROBLEM SET 6.4, page 247

2. The subsidiary equation is

$$(s^2 + 2s + 2)Y = 1 + \frac{1}{1 + s} + 5e^{-2s}$$

where the 1 comes from  $y'(0)$ . The solution in terms of partial fractions is

$$Y = \frac{1}{(s + 1)^2 + 1} + \frac{1}{1 + s} - \frac{s + 1}{(s + 1)^2 + 1} + \frac{5e^{-2s}}{(s + 1)^2 + 1}.$$

Hence the inverse transform (the solution of the problem) is

$$y = e^{-t} \sin t + e^{-t} - e^{-t} \cos t + 5e^{-(t-2)} \sin(t - 2) u(t - 2).$$

4. The subsidiary equation is

$$(s^2 + 3s + 2)Y = s - 1 + 3 + \frac{10}{s^2 + 1} + 10e^{-s}.$$

In terms of partial fractions, its solution is

$$Y = \frac{-2}{s+2} + \frac{6}{s+1} - \frac{3s-1}{s^2+1} + 10 \left( \frac{1}{s+1} - \frac{1}{s+2} \right) e^{-s}.$$

Its inverse transform is

$$y = -2e^{-2t} + 6e^{-t} - 3 \cos t + \sin t + 10u(t-1) [e^{-t+1} - e^{-2(t-1)}].$$

Without the  $\delta$ -term, the solution is  $-3 \cos t + \sin t - 2e^{-2t} + 6e^{-t}$  and approaches a harmonic oscillation fairly soon. With the  $\delta$ -term the first half-wave has a maximum amplitude of about 5, but from about  $t = 8$  or 10 on its graph coincides practically with the graph of that harmonic oscillation (whose maximum amplitude is  $\sqrt{10}$ ). This is physically understandable, since the system has damping that eventually consumes the additional energy due to the  $\delta$ -term.

6. The subsidiary equation is

$$(s^2 + 2s - 3)Y = s + 2 + 100(e^{-2s} + e^{-3s}).$$

The solution is

$$Y = \frac{s + 2 + 100(e^{-2s} + e^{-3s})}{(s-1)(s+3)}.$$

Its inverse transform gives the solution of the problem,

$$y = \frac{1}{4}(e^{-3t} + 3e^t) - 25u(t-2)(e^{-3t+6} - e^{t-2}) + 25u(t-3)(-e^{-3t+9} + e^{t-3}).$$

Without the factor 100 the cusps of the curve at  $t = 2$  and  $t = 3$  caused by the delta functions would hardly be visible in the graph, because the solution increases exponentially. Solve the problem without the factor 100.

8. The subsidiary equation is

$$(s^2 + 5s + 6)Y = e^{-\pi s/2} - \frac{s}{s^2+1} e^{-\pi s}.$$

Its solution is

$$Y = \left( \frac{1}{s+2} - \frac{1}{s+3} \right) e^{-\pi s/2} - \left( -\frac{0.4}{s+2} + \frac{0.3}{s+3} + \frac{0.1(s+1)}{s^2+1} \right) e^{-\pi s}.$$

The inverse transform of  $Y$  is

$$y = u(t - \frac{1}{2}\pi) [e^{-2t+\pi} - e^{-3t+3\pi/2}] - 0.1u(t - \pi) [-4e^{-2t+2\pi} + 3e^{-3t+3\pi} - \cos t - \sin t].$$

This solution is zero from 0 to  $\frac{1}{2}\pi$  and then increases rapidly. Its first negative half-wave has a smaller maximum amplitude (about 0.1) than the continuation as a harmonic oscillation with maximum amplitude of about 0.15.

10. This is Prob. 9 without the damping term. The subsidiary equation is

$$(s^2 + 5)Y = -2s + 5 + \frac{25}{s^2} - 100e^{-\pi s}.$$

Its solution is

$$Y = \frac{-2s+5}{s^2+5} + \frac{25}{s^2(s^2+5)} - \frac{100}{s^2+5} e^{-\pi s}.$$

The partial fraction reduction of the second term on the right is

$$5 \left( \frac{1}{s^2} - \frac{1}{s^2 + 5} \right).$$

The inverse transform of  $Y$  is (note that the sine terms cancel)

$$y = -2 \cos t\sqrt{5} + 5t - 20\sqrt{5}u(t - \pi) \sin(\sqrt{5}(t - \pi)).$$

The graph begins at  $t = 0$  according to  $5t - 2 \cos t\sqrt{5}$  (the solution without the  $\delta$ -term) and then starts oscillating with maximum amplitude of about 40 about the straight line given by  $5t$ . Since there is no damping, the energy corresponding to the  $\delta$ -term imposed at  $t = \pi$  will not disappear from the system; hence we obtain the indicated oscillations. See the figure.

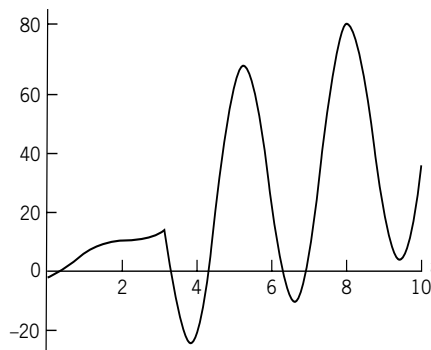

Section 6.4. Problem 10

12. The subsidiary equation is

$$(s^2 + 1)Y = 1 - \frac{2}{s^2 + 1} + 10e^{-\pi s}.$$

Its solution is

$$Y = \frac{1}{s^2 + 1} - \frac{2}{(s^2 + 1)^2} + \frac{10}{s^2 + 1} e^{-\pi s}.$$

The inverse transform of  $Y$  is

$$\begin{aligned} y &= \sin t - (\sin t - t \cos t) - 10u(t - \pi) \sin t \\ &= t \cos t - 10u(t - \pi) \sin t. \end{aligned}$$

We see that we have a resonance term,  $t \cos t$ . At  $t = \pi$  the graph has a sharp cusp and then shows the oscillations with increasing maximum amplitude to be expected in the case of resonance. See the figure.

14. **CAS Project.** Students should become aware that careful observation of graphs may lead to discoveries or to more information about conjectures that they may want to prove or disprove. The curves branch from the solution of the homogeneous ODE at the instant at which the impulse is applied, which by choosing, say,  $a = 1, 2, 3, \dots$ , gives an interesting joint graph.
16. **Team Project.** (a) If  $f(t)$  is piecewise continuous on an interval of length  $p$ , then its Laplace transform exists, and we can write the integral from zero to infinity as the series of integrals over successive periods:

$$\mathcal{L}(f) = \int_0^{\infty} e^{-st} f(t) dt = \int_0^p e^{-st} f(t) dt + \int_p^{2p} e^{-st} f(t) dt + \int_{2p}^{3p} e^{-st} f(t) dt + \dots$$

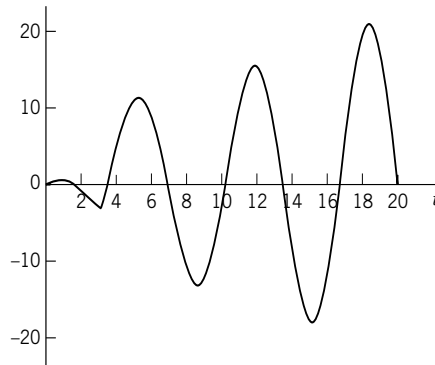

Section 6.4. Problem 12

If we substitute  $t = \tau + p$  in the second integral,  $t = \tau + 2p$  in the third integral,  $\dots$ ,  $t = \tau + (n - 1)p$  in the  $n$ th integral,  $\dots$ , then the new limits in every integral are 0 and  $p$ . Since

$$f(\tau + p) = f(\tau), \quad f(\tau + 2p) = f(\tau),$$

etc., we thus obtain

$$\mathcal{L}(f) = \int_0^p e^{-s\tau} f(\tau) d\tau + \int_0^p e^{-s(\tau+p)} f(\tau) d\tau + \int_0^p e^{-s(\tau+2p)} f(\tau) d\tau + \dots$$

The factors that do not depend on  $\tau$  can be taken out from under the integral signs; this gives

$$\mathcal{L}(f) = [1 + e^{-sp} + e^{-2sp} + \dots] \int_0^p e^{-s\tau} f(\tau) d\tau.$$

The series in brackets  $[\dots]$  is a geometric series whose sum is  $1/(1 - e^{-ps})$ . The theorem now follows.

(b) From (11) we obtain

$$\mathcal{L}(f) = \frac{1}{1 - e^{-2\pi s/\omega}} \int_0^{\pi/\omega} e^{-st} \sin \omega t dt.$$

Using  $1 - e^{-2\pi s/\omega} = (1 + e^{-\pi s/\omega})(1 - e^{-\pi s/\omega})$  and integrating by parts or noting that the integral is the imaginary part of the integral

$$\int_0^{\pi/\omega} e^{(-s+i\omega)t} dt = \frac{1}{-s+i\omega} e^{(-s+i\omega)t} \Big|_0^{\pi/\omega} = \frac{-s-i\omega}{s^2+\omega^2} (-e^{-s\pi/\omega} - 1)$$

we obtain the result.

(c) From (11) we obtain the following equation by using  $\sin \omega t$  from 0 to  $\pi/\omega$  and  $-\sin \omega t$  from  $\pi/\omega$  to  $2\pi/\omega$ :

$$\begin{aligned} \frac{\omega}{s^2 + \omega^2} \frac{1 + e^{\pi s/\omega}}{e^{\pi s/\omega} - 1} &= \frac{\omega}{s^2 + \omega^2} \frac{e^{-\pi s/2\omega} + e^{\pi s/2\omega}}{e^{\pi s/2\omega} - e^{-\pi s/2\omega}} \\ &= \frac{\omega}{s^2 + \omega^2} \frac{\cosh(\pi s/2\omega)}{\sinh(\pi s/2\omega)}. \end{aligned}$$

This gives the result.

(d) The sawtooth wave has the representation

$$f(t) = \frac{k}{p} t \quad \text{if } 0 < t < p, \quad f(t + p) = f(t).$$

Integration by parts gives

$$\begin{aligned}\int_0^p e^{-st} t dt &= -\frac{t}{s} e^{-st} \Big|_0^p + \frac{1}{s} \int_0^p e^{-st} dt \\ &= -\frac{p}{s} e^{-sp} - \frac{1}{s^2} (e^{-sp} - 1)\end{aligned}$$

and thus from (11) we obtain the result

$$\mathcal{L}(f) = \frac{k}{ps^2} - \frac{ke^{-ps}}{s(1 - e^{-ps})} \quad (s > 0).$$

(e) Since  $kt/p$  has the transform  $k/ps^2$ , from (d) we have the result

$$\frac{ke^{-ps}}{s(1 - e^{-ps})} \quad (s > 0).$$

### SECTION 6.5. Convolution. Integral Equations, page 248

**Purpose.** To find the inverse  $h(t)$  of a product  $H(s) = F(s)G(s)$  of transforms whose inverses are known.

#### Main Content, Important Concepts

Convolution  $f * g$ , its properties

Convolution theorem

Application to ODEs and integral equations

#### Comment on Occurrence

In an ODE the transform  $R(s)$  of the right side  $r(t)$  is known from Step 1. Solving the subsidiary equation algebraically for  $Y(s)$  causes the transform  $R(s)$  to be multiplied by the reciprocal of the factor of  $Y(s)$  on the left (the transfer function  $Q(s)$ ; see Sec. 6.2). This calls for the convolution theorem, unless one sees some other way or shortcut.

**Very Short Courses.** This section can be omitted.

### SOLUTIONS TO PROBLEM SET 6.5, page 253

$$2. t * t = \int_0^t \tau(t - \tau) d\tau = \frac{t^3}{2} - \frac{t^3}{3} = \frac{t^3}{6}$$

$$4. \int_0^t e^{a\tau} e^{b(t-\tau)} d\tau = e^{bt} \int_0^t e^{(a-b)\tau} d\tau = \frac{e^{bt}}{a-b} (e^{(a-b)t} - 1) = \frac{1}{a-b} (e^{at} - e^{bt})$$

$$6. 1 * f(t) = \int_0^t f(\tau) d\tau$$

8. By the definition and by (11) in App. 3.1 we obtain

$$\int_0^t \sin \tau \cos(t - \tau) d\tau = \frac{1}{2} \int_0^t \sin t d\tau + \frac{1}{2} \int_0^t \sin(2\tau - t) d\tau.$$

Integration of this gives

$$\frac{1}{2} t \sin t + \left[ \frac{1}{4} (-\cos(2\tau - t)) \right]_0^t = \frac{1}{2} t \sin t - \frac{1}{4} [\cos t - \cos(-t)].$$

Hence the answer is  $\frac{1}{2} t \sin t$ .

$$10. \mathcal{L}(1)\mathcal{L}(e^t), 1 * e^t = \int_0^t e^\tau d\tau = e^t - 1$$

$$12. t * e^{2t} = \int_0^t e^{2\tau}(t - \tau) d\tau = \frac{t}{2}(e^{2t} - 1) - \frac{t}{2}e^{2t} + \frac{1}{4}e^{2t} - \frac{1}{4} \\ = -\frac{t}{2} + \frac{1}{4}e^{2t} - \frac{1}{4}$$

$$14. \frac{1}{4}(\cos 4t) * (\sin 4t) = \frac{1}{4} \int_0^t \cos 4\tau \sin 4(t - \tau) d\tau. \text{ Use (11) in App. 3.1 to convert the product in the integrand to a sum and integrate. This gives}$$

$$\frac{1}{4} \int_0^t \frac{1}{2} (\sin 4t + \sin(4t - 8\tau)) d\tau = \frac{t}{8} \sin 4t + \frac{1}{64} (\cos 4t - \cos(-4t)).$$

Hence the *answer* is  $\frac{t}{8} \sin 4t$ , in agreement with formula 22 in Sec. 6.9.

$$16. (\sin t) * (\sin 5t) = \int_0^t \sin \tau \sin 5(t - \tau) d\tau. \text{ Using formula (11) in App. 3.1, convert the product in the integrand to a sum and integrate, obtaining}$$

$$\frac{1}{2} \int_0^t [-\cos(5t - 4\tau) + \cos(\tau - 5t + 5\tau)] d\tau \\ = \frac{1}{2} \left[ -\frac{1}{4} \sin(-5t + 4\tau) + \frac{1}{6} \sin(6\tau - 5t) \right] \Big|_0^t \\ = \frac{1}{8}(\sin t - \sin 5t) + \frac{1}{12}(\sin t + \sin 5t) \\ = \frac{5}{24} \sin t - \frac{1}{24} \sin 5t.$$

18. The subsidiary equation is

$$(s^2 + 1)Y = \frac{1}{s^2 + 1}$$

and has the solution

$$Y = \frac{1}{(s^2 + 1)^2}.$$

Since the inverse of  $1/(s^2 + 1)$  is  $\sin t$ , the convolution theorem gives the *answer*

$$y = (\sin t) * (\sin t) = \int_0^t \sin \tau \sin(t - \tau) d\tau \\ = -\frac{1}{2}t \cos t + \frac{1}{2} \sin t.$$

20. The subsidiary equation is

$$(s + 1)(s + 4)Y = \frac{2}{s + 2}.$$

Its solution is

$$Y = \frac{2}{(s + 1)(s + 2)(s + 4)}.$$

Two applications of the convolution theorem thus give

$$\begin{aligned}(2e^{-t} * e^{-2t}) * e^{-4t} &= \int_0^t \left( 2 \int_0^p e^{-\tau} e^{-2p+2\tau} d\tau \right) e^{-4t+4p} dp \\ &= \int_0^t (2e^{-p} - 2e^{-2p}) e^{-4t+4p} dp \\ &= \frac{2}{3} e^{-t} - e^{-2t} + \frac{1}{3} e^{-4t}.\end{aligned}$$

22. The subsidiary equation is

$$(s^2 + 3s + 2)Y = \frac{1 - e^{-as}}{s}.$$

Now

$$\frac{1}{s^2 + 3s + 2} = \frac{1}{(s+1)(s+2)} = \frac{1}{s+1} - \frac{1}{s+2}.$$

The inverse transform of this is  $e^{-t} - e^{-2t}$ . Hence, since  $r(t) = 1$  if  $t < a$  and 0 thereafter, this gives

$$\begin{aligned}r(t) * (e^{-t} - e^{-2t}) &= \int (e^{-(t-\tau)} - e^{-2(t-\tau)}) d\tau \\ &= e^{-(t-\tau)} - \frac{1}{2}e^{-2(t-\tau)}.\end{aligned}$$

If  $t < a$ , the limits of integration are 0 and  $t$ ; this gives

$$y(t) = 1 - e^{-t} - \frac{1}{2} + \frac{1}{2}e^{-2t} = \frac{1}{2} - e^{-t} + \frac{1}{2}e^{-2t}.$$

If  $t > a$ , we integrate from 0 to  $a$ , obtaining

$$y(t) = e^{-(t-a)} - e^{-t} - \frac{1}{2}e^{-2(t-a)} + \frac{1}{2}e^{-2t}.$$

Using the subsidiary equation (above) and a partial fraction expansion, we obtain

$$Y = (1 - e^{-as}) \left( \frac{1}{2s} + \frac{1}{2(s+2)} - \frac{1}{s+1} \right)$$

and the same expressions for  $y(t)$ .

24. The subsidiary equation is

$$(s^2 + 5s + 6)Y = s + 5 + e^{-3s}.$$

Its solution is

$$Y = \frac{s + 5 + e^{-3s}}{(s+2)(s+3)} = \frac{3}{s+2} - \frac{2}{s+3} + \left( \frac{1}{s+2} - \frac{1}{s+3} \right) e^{-3s}.$$

The inverse transform of the first two terms on the right is

$$3e^{-2t} - 2e^{-3t}.$$

The inverse transform of the last two terms can be obtained by the second shifting theorem or by convolution. By convolution we use the sifting property, formula (4) in Sec. 6.4. We obtain

$$\delta(t-3) * (e^{-2t} - e^{-3t}) = \int_0^t [e^{-2(t-\tau)} - e^{-3(t-\tau)}] \delta(\tau-3) d\tau.$$

For  $t < 3$  this gives 0. For  $t > 3$  we obtain

$$e^{-2(t-3)} - e^{-3(t-3)}.$$



**26. Team Project.** (a) Setting  $t - \tau = p$ , we have  $\tau = t - p$ ,  $d\tau = -dp$ , and  $p$  runs from  $t$  to 0; thus

$$\begin{aligned} f * g &= \int_0^t f(\tau)g(t - \tau) d\tau = \int_t^0 g(p)f(t - p) (-dp) \\ &= \int_0^t g(p)f(t - p) dp = g * f. \end{aligned}$$

(b) Interchanging the order of integration and noting that we integrate over the shaded triangle in the figure, we obtain

$$\begin{aligned} (f * g) * v &= v * (f * g) \\ &= \int_0^t v(p) \int_0^{t-p} f(\tau)g(t - p - \tau) d\tau dp \\ &= \int_0^t f(\tau) \int_0^{t-\tau} g(t - \tau - p)v(p) dp d\tau \\ &= f * (g * v). \end{aligned}$$

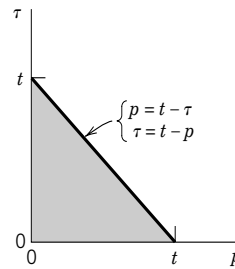

**Section 6.5.** Team Project 26(b)

(c) This is a simple consequence of the additivity of the integral.

(d) Let  $t > k$ . Then  $(f_k * f)(t) = \int_0^k \frac{1}{k} f(t - \tau) d\tau = f(t - \tilde{t})$  for some  $\tilde{t}$  between 0 and  $k$ . Now let  $k \rightarrow 0$ . Then  $\tilde{t} \rightarrow 0$  and  $f_k(t - \tilde{t}) \rightarrow \delta(t)$ , so that the formula follows.

(e)  $s^2Y - sy(0) - y'(0) + \omega^2Y = \mathcal{L}(r)$  has the solution

$$Y = \frac{1}{\omega} \left( \frac{\omega}{s^2 + \omega^2} \right) \mathcal{L}(r) + y(0) \frac{s}{s^2 + \omega^2} + \frac{y'(0)}{\omega} \frac{\omega}{s^2 + \omega^2}$$

etc.

**28.** The integral equation can be written

$$y(t) + y(t) * \cosh t = t + e^t.$$

This implies by the convolution theorem that its transform is

$$Y + \frac{s}{s^2 - 1} Y = \frac{1}{s^2} + \frac{1}{s - 1}.$$

The solution is

$$Y = \frac{s^2 - 1}{s^2 + s - 1} \left( \frac{1}{s^2} + \frac{1}{s - 1} \right) = \frac{1}{s^2} + \frac{1}{s}.$$

Hence its inverse transform gives the *answer*  $y(t) = t + 1$ . This result can easily be checked by substitution into the given equation and integration.

$$30. Y + \frac{2s}{s^2 + 1} Y = \frac{s^2 + 2s + 1}{s^2 + 1} Y = \frac{s}{s^2 + 1}, \text{ hence}$$

$$Y = \frac{1}{s + 1} - \frac{1}{(s + 1)^2}.$$

This gives the *answer*  $y = (1 - t)e^{-t}$ .

$$32. Y \left( 1 - \frac{1}{s^2} \right) = \frac{2}{s} - \frac{1}{s^3}, \text{ hence}$$

$$Y = \frac{2s^2 - 1}{s(s^2 - 1)} = \frac{1}{s} + \frac{s}{s^2 - 1}.$$

The *answer* is  $y = 1 + \cosh t$ .

$$34. Y \left( 1 + \frac{1}{s - 2} \right) = \frac{2}{s^3} - \frac{1}{s^2} - \frac{1}{2s} + \frac{1}{2(s - 2)}, Y = \frac{4}{s^3}, y = 2t^2$$

### SECTION 6.6. Differentiation and Integration of Transforms. ODEs with Variable Coefficients, page 254

**Purpose.** To show that, *roughly*, differentiation and integration of transforms (not of functions, as before!) corresponds to multiplication and division, respectively, of functions by  $t$ , with application to the derivation of further transforms and to the solution of Laguerre's differential equation.

#### Comment on Application to Variable-Coefficient Equations

This possibility is rather limited; our Example 3 is perhaps the best elementary example of practical interest.

**Very Short Courses.** This section can be omitted.

### SOLUTIONS TO PROBLEM SET 6.6, page 257

$$2. \left( \frac{s}{s^2 - 4} \right)' = \frac{s^2 - 4 - 2s^2}{(s^2 - 4)^2} = -\frac{s^2 + 4}{(s^2 - 4)^2}$$

4. By the addition formula for the cosine we have

$$\cos(t + k) = \cos t \cos k - \sin t \sin k.$$

The transform of this function is

$$\frac{s \cos k - \sin k}{s^2 + 1}.$$

The derivative times  $-1$  is

$$-\frac{\cos k (s^2 + 1) - (s \cos k - \sin k)2s}{(s^2 + 1)^2}.$$

Simplification gives the *answer*

$$\frac{(s^2 - 1) \cos k - 2s \sin k}{(s^2 + 1)^2}.$$

6. We need two differentiations. We can drop the two minus signs. Starting from the transform of  $\sin 3t$ , we obtain

$$\begin{aligned} \left( \frac{3}{s^2 + 9} \right)'' &= \left( \frac{-6s}{(s^2 + 9)^2} \right)' \\ &= \frac{-6(s^2 + 9)^2 + 6s \cdot 2(s^2 + 9) \cdot 2s}{(s^2 + 9)^4} \\ &= \frac{-6s^2 - 54 + 24s^2}{(s^2 + 9)^3} \\ &= \frac{18(s^2 - 3)}{(s^2 + 9)^3}. \end{aligned}$$

8.  $\mathcal{L}(t^n e^{kt}) = \frac{n!}{(s - k)^{n+1}}$  can be obtained from  $\mathcal{L}(e^{kt}) = \frac{1}{s - k}$  by  $n$  subsequent differentiations,

$$\left( \frac{1}{s - k} \right)^{(n)} = \left( \frac{-1}{(s - k)^2} \right)^{(n-1)} = \cdots = \frac{(-1)^n n!}{(s - k)^{n+1}}$$

and multiplication by  $(-1)^n$  (to take care of the minus sign in (1) in each of the  $n$  steps), or much more simply, by the first shifting theorem, starting from  $\mathcal{L}(t^n) = n!/s^{n+1}$ .

$$10. -\left( \frac{s}{s^2 + \omega^2} \right)' = -\frac{s^2 + \omega^2 - 2s^2}{(s^2 + \omega^2)^2} = \frac{s^2 - \omega^2}{(s^2 + \omega^2)^2}$$

$$12. -\left( \frac{1}{(s + k)^2 + 1} \right)' = \frac{2(s + k)}{((s + k)^2 + 1)^2}$$

14. By differentiation we have

$$\left( \frac{4}{s^2 + 16} \right)' = \frac{-8s}{(s^2 + 16)^2}.$$

Hence the *answer* is  $\frac{1}{8}t \sin 4t$ . By integration we see that

$$\int_s^\infty \frac{\tilde{s}}{(\tilde{s}^2 + 16)^2} d\tilde{s} = \frac{\frac{1}{2}}{s^2 + 16}$$

has the inverse transform  $\frac{1}{8} \sin 4t$  and gives the same answer. By convolution,

$$(\cos 4t) * \left( \frac{1}{4} \sin 4t \right) = \int_0^t \cos 4\tau \sin (4t - 4\tau) d\tau$$

and gives the same answer.

16. By differentiation

$$\left( \frac{1}{s^2 - 1} \right)' = \frac{-2s}{(s^2 - 1)^2}.$$

This shows that the *answer* is  $\frac{1}{2}t \sinh t$ .

18.  $\ln \frac{s+a}{s+b} = \ln(s+a) - \ln(s+b) = -\int_s^\infty \frac{d\sigma}{\sigma+a} + \int_s^\infty \frac{d\sigma}{\sigma+b}$ . This shows that the answer is  $(-e^{-at} + e^{-bt})/t$ .

20.  $\left(\operatorname{arccot} \frac{s}{\omega}\right)' = -\frac{1/\omega}{1 + \left(\frac{s}{\omega}\right)^2} = \frac{-\omega}{s^2 + \omega^2}$  shows that the answer is  $(\sin \omega t)/t$ .

22. **CAS Project.** Students should become aware that usually there are several possibilities for calculations, and they should not rush into numerical work before carefully selecting formulas.

(b) Use the usual rule for differentiating a product  $n$  times. Some of the polynomials are

$$l_2 = 1 - 2t + \frac{1}{2}t^2$$

$$l_3 = 1 - 3t + \frac{3}{2}t^2 - \frac{1}{6}t^3$$

$$l_4 = 1 - 4t + 3t^2 - \frac{2}{3}t^3 + \frac{1}{24}t^4$$

$$l_5 = 1 - 5t + 5t^2 - \frac{5}{3}t^3 + \frac{5}{24}t^4 - \frac{1}{120}t^5.$$

### SECTION 6.7. Systems of ODEs, page 258

**Purpose.** This section explains the application of the Laplace transform to systems of ODEs in terms of three typical examples: a mixing problem, an electrical network, and a system of several (two) masses on elastic springs.

### SOLUTIONS TO PROBLEM SET 6.7, page 262

2. The subsidiary equations are

$$sY_1 - 1 = 5Y_1 + Y_2$$

$$sY_2 + 3 = Y_1 + 5Y_2.$$

The solution is

$$Y_1 = \frac{s-8}{(s-5)^2-1} = \frac{(s-5)-3}{(s-5)^2-1}$$

$$Y_2 = \frac{-3s+16}{(s-5)^2-1} = \frac{-3(s-5)+1}{(s-5)^2-1}.$$

The inverse transform is

$$y_1 = e^{5t} \cosh t - 3e^{5t} \sinh t = 2e^{4t} - e^{6t}$$

$$y_2 = -3e^{5t} \cosh t + e^{5t} \sinh t = -2e^{4t} - e^{6t}.$$

4. The subsidiary equations are

$$sY_1 + Y_2 = 1$$

$$Y_1 + sY_2 = \frac{2s}{s^2+1}.$$

The solution is

$$Y_1 = \frac{s}{s^2+1}, \quad Y_2 = \frac{1}{s^2+1}.$$

The inverse transform is  $y_1 = \cos t$ ,  $y_2 = \sin t$ .

6. The subsidiary equations are

$$sY_1 = 4Y_2 - \frac{8s}{s^2 + 16}$$

$$sY_2 = 3 - 3Y_1 - \frac{36}{s^2 + 16}.$$

The solution is

$$Y_1 = \frac{4}{s^2 + 16}, \quad Y_2 = \frac{3s}{s^2 + 16}.$$

The inverse transform is  $y_1 = \sin 4t$ ,  $y_2 = 3 \cos 4t$ .

8. The subsidiary equations are

$$sY_1 = -3 + 6Y_1 + Y_2$$

$$sY_2 = -3 + 9Y_1 + 6Y_2.$$

The solution is

$$Y_1 = \frac{-3s + 15}{s^2 - 12s + 27} = -\frac{2}{s - 9} - \frac{1}{s - 3}$$

$$Y_2 = \frac{-3s - 9}{s^2 - 12s + 27} = -\frac{6}{s - 9} + \frac{3}{s - 3}.$$

The inverse transform is

$$y_1 = -2e^{9t} - e^{3t}, \quad y_2 = -6e^{9t} + 3e^{3t}.$$

10. The subsidiary equations are

$$sY_1 = 4 - 2Y_1 + 3Y_2$$

$$sY_2 = 3 + 4Y_1 - Y_2.$$

The solution is

$$Y_1 = \frac{4s + 13}{s^2 + 3s - 10} = \frac{3}{s - 2} + \frac{1}{s + 5}$$

$$Y_2 = \frac{3s + 22}{s^2 + 3s - 10} = \frac{4}{s - 2} - \frac{1}{s + 5}.$$

The inverse transform is

$$y_1 = 3e^{2t} + e^{-5t}, \quad y_2 = 4e^{2t} - e^{-5t}.$$

12. The subsidiary equations are

$$sY_1 = 2 + 2Y_1 + Y_2$$

$$sY_2 = 4Y_1 + 2Y_2 + 64e^{-s} \left( \frac{1}{s^2} + \frac{1}{s} \right).$$

The solution is

$$Y_1 = 2 \left[ \frac{1}{s - 4} - \frac{2}{s(s - 4)} + \frac{32e^{-s}}{s - 4} \left( \frac{1}{s^2} + \frac{1}{s^3} \right) \right]$$

$$Y_2 = 8 \left[ \frac{1}{s(s - 4)} + \frac{8e^{-s}}{s - 4} \left( \frac{1}{s} - \frac{1}{s^2} - \frac{2}{s^3} \right) \right].$$

Using partial fraction expansions

$$\frac{1}{s-4} - \frac{2}{s(s-4)} = \frac{1}{2(s-4)} + \frac{1}{2s}$$

and

$$64 \left( \frac{1}{s^2(s-4)} + \frac{1}{s^3(s-4)} \right) = -\frac{5}{s} - \frac{20}{s^2} - \frac{16}{s^3} + \frac{5}{s-4}$$

which because of  $e^{-s}$  gives the inverse transform

$$-5 - 20(t-1) - 8(t-1)^2 + 5e^{4(t-1)}$$

and similarly for the expressions in  $Y_2$ , we obtain the inverse transforms of  $Y_1$  and  $Y_2$  in the form

$$y_1 = 1 + e^{4t} + u(t-1) [-8t^2 - 4t + 7 + 5e^{4t-4}]$$

$$y_2 = -2 + 2e^{4t} + u(t-1) [16t^2 - 8t - 18 + 10e^{4t-4}].$$

14. The subsidiary equations are

$$sY_1 = 1 - Y_2$$

$$sY_2 = -Y_1 + \frac{2s}{s^2+1} - \frac{2e^{-2\pi s}}{s^2+1}.$$

The solution is

$$\begin{aligned} Y_1 &= \frac{s(s^2-1+2e^{-2\pi s})}{s^4-1} \\ &= \frac{s}{s^2+1} + \frac{2se^{-2\pi s}}{s^4-1} \\ &= \frac{s}{s^2+1} + e^{-2\pi s} \left( \frac{1/2}{s-1} + \frac{1/2}{s+1} - \frac{s}{s^2+1} \right) \\ Y_2 &= \frac{s^2-1-2s^2e^{-2\pi s}}{s^4-1} \\ &= \frac{1}{s^2+1} + e^{-2\pi s} \left( \frac{1}{2} \left( \frac{1}{s+1} - \frac{1}{s-1} \right) - \frac{1}{s^2+1} \right). \end{aligned}$$

The inverse transform is

$$y_1 = \cos t + u(t-2\pi) \left[ -\cos t + \frac{1}{2}(e^{-t+2\pi} + e^{t-2\pi}) \right]$$

$$y_2 = \sin t + u(t-2\pi) \left[ -\sin t + \frac{1}{2}(e^{-t+2\pi} - e^{t-2\pi}) \right].$$

Thus  $y_1 = \cos t$  and  $y_2 = \sin t$  if  $0 < t < 2\pi$ ;  $y_1 = \cosh(t-2\pi)$ , and  $y_2 = -\sinh(t-2\pi)$  if  $t > 2\pi$ .

16. The subsidiary equations are

$$s^2Y_1 = s - 2Y_1 + 2Y_2$$

$$s^2Y_2 = 3s + 2Y_1 - 5Y_2.$$

The solution is

$$Y_1 = \frac{s(s^2+11)}{s^4+7s^2+6} = \frac{2s}{s^2+1} - \frac{s}{s^2+6}$$

$$Y_2 = \frac{s(3s^2+8)}{s^4+7s^2+6} = \frac{s}{s^2+1} + \frac{2s}{s^2+6}.$$

Hence the inverse transform is

$$y_1 = 2 \cos t - \cos t\sqrt{6}, \quad y_2 = \cos t + 2 \cos t\sqrt{6}.$$

18. The subsidiary equations are

$$s^2 Y_1 = 6 - Y_2 - \frac{1010}{s^2 + 100}$$

$$s^2 Y_2 = 8s - 6 - Y_1 + \frac{1010}{s^2 + 100}.$$

The solution is, in terms of partial fractions,

$$Y_1 = \frac{-4}{s-1} + \frac{10}{s^2+100} + \frac{4s}{s^2+1}$$

$$Y_2 = \frac{4}{s-1} - \frac{10}{s^2+100} + \frac{4s}{s^2+1}.$$

The inverse transform is

$$y_1 = -4e^t + \sin 10t + 4 \cos t$$

$$y_2 = 4e^t - \sin 10t + 4 \cos t.$$

20. The subsidiary equations are

$$4sY_1 - 8 + sY_2 - 2sY_3 = 0$$

$$-2sY_1 + 4 + sY_3 = \frac{1}{s}$$

$$2sY_2 - 4sY_3 = -\frac{16}{s^2}.$$

The solution is

$$Y_1 = 2 \left( \frac{1}{s} + \frac{1}{s^3} \right), \quad Y_2 = \frac{2}{s^2}, \quad Y_3 = \frac{1}{s^2} + \frac{4}{s^3}.$$

The inverse transform is

$$y_1 = 2 + t^2, \quad y_2 = 2t, \quad y_3 = t + 2t^2.$$

22. The subsidiary equations are

$$s^2 Y_1 - s - 1 = -8Y_1 + 4Y_2 + \frac{11}{s^2 + 1}$$

$$s^2 Y_2 - s + 1 = -8Y_2 + 4Y_1 - \frac{11}{s^2 + 1}.$$

The solution, in terms of partial fractions, is

$$Y_1 = \frac{s}{s^2+4} + \frac{1}{s^2+1}$$

$$Y_2 = \frac{s}{s^2+4} - \frac{1}{s^2+1}.$$

The inverse transform is

$$y_1 = \cos 2t + \sin t$$

$$y_2 = \cos 2t - \sin t.$$

24. The new salt contents are

$$y_1 = 100 - 62.5e^{-0.24t} - 37.5e^{-0.08t}$$

$$y_2 = 100 + 125e^{-0.24t} - 75e^{-0.08t}.$$

Setting  $2t = \tau$  gives the old solution, except for notation.

26. For  $0 \leq t \leq 2\pi$  the solution is as in Prob. 25; for  $i_1$  we have

$$i_1 = -26e^{-2t} - 16e^{-8t} + 42 \cos t + 15 \sin t.$$

For  $t > 2\pi$  we have to add to this further terms whose form is determined by this solution and the second shifting theorem,

$$u(t - 2\pi) [26e^{-2t+4\pi} + 16e^{-8t+16\pi} - 42 \cos t - 15 \sin t].$$

The cosine and sine terms cancel, so that

$$i_1 = -26(1 - e^{4\pi})e^{-2t} + 16(1 - e^{16\pi})e^{-8t} \quad \text{if } t > 2\pi.$$

Similarly, for  $i_2$  we obtain

$$i_2 = \begin{cases} -26e^{-2t} + 8e^{-8t} + 18 \cos t + 12 \sin t \\ -26(1 - e^{4\pi})e^{-2t} + 8(1 - e^{16\pi})e^{-8t}. \end{cases}$$

### SOLUTIONS TO CHAP. 6 REVIEW QUESTIONS AND PROBLEMS, page 267

12.  $\frac{2}{(s+1)^2+4}$ , one of the transforms in Table 6.1

14.  $\cos^2 4t = \frac{1}{2} + \frac{1}{2} \cos 8t$ . The transform is

$$\frac{1/2}{s} + \frac{s/2}{s^2+64} = \frac{s^2+32}{s(s^2+64)}.$$

16.  $u(t-2\pi) \sin t = u(t-2\pi) \sin(t-2\pi)$ . Hence the transform is  $e^{-2\pi s}/(s^2+1)$ .

18.  $\sin \omega t$  has the transform  $\omega/(s^2+\omega^2)$ , and  $\cos \omega t$  has the transform  $s/(s^2+\omega^2)$ . Hence, by convolution, the given function

$$(\sin \omega t) * (\cos \omega t) = \frac{1}{2}t \sin \omega t$$

has the transform

$$\frac{\omega s}{(s^2+\omega^2)^2}.$$

20.  $\frac{2s}{s^4-1}$ . Problems 17–22 illustrate that sums of expressions can often be combined to an expression of a new form. This motivates that, conversely, partial fraction expansions are helpful in finding inverse transforms.

22.  $\frac{s}{s^2-4} - \frac{s}{s^2-1} = \frac{3s}{(s^2-4)(s^2-1)}$

24.  $7.5 \sinh 2t$



26.  $\frac{3s}{s^2 - 2s + 2} = \frac{3(s-1) + 3}{(s-1)^2 + 1}$ . Hence the inverse transform is

$$3e^t(\cos t + \sin t).$$

28.  $\frac{2s-10}{s^3} = \frac{2}{s^2} - \frac{10}{s^3}$ . This shows that the inverse transform is

$$\begin{aligned} u(t-5) [2(t-5) - 5(t-5)^2] \\ = u(t-5) [-5t^2 + 52t - 135]. \end{aligned}$$

30. The given transform suggests the differentiation

$$\left( \frac{s}{s^2 + 16} \right)' = \frac{s^2 + 16 - s \cdot 2s}{(s^2 + 16)^2} = -\frac{s^2 - 16}{(s^2 + 16)^2}$$

and shows that the *answer* is  $t \cos 4t$ .

32.  $\frac{1}{4}(t^6 + 3t^4 + 6t^2)$

34.  $\frac{1}{2s^2 + 2s + 1} = \frac{1/2}{(s + 1/2)^2 + 1/4}$ . Hence  $2e^{-t/2} \sin \frac{1}{2}t$ .

36.  $y = -\cos 4t + u(t - \pi) \sin 4t$ . To see the impact of  $4\delta(t - \pi)$ , graph both the solution and the term  $-\cos 4t$ , perhaps in a short  $t$ -interval with midpoint  $\pi$ .

38.  $y = 0$  if  $0 < t < 2$  and  $1 - \cos(t - 2)$  if  $t > 2$

40.  $y = e^{-2t}(13 \cos t + 11 \sin t) + 10t - 8$

42.  $Y = e^{-s}/(s-1)^2$ ,  $y = e^{t-1}(t-1)u(t-1)$

44.  $y = \cos 2t + \frac{1}{2}[u(t - \pi) - u(t - 2\pi)] \sin 2t$ . The curve has cusps at  $t = \pi$  and  $2\pi$  (abrupt changes of the tangent direction).

46.  $y_1 = 8e^t - 5e^{-2t} - 18t - 3$ ,  $y_2 = 32e^t - 5e^{-2t} - 42t - 27$

48.  $y_1 = \frac{1}{2}u(t - \pi) \sin 2t$ ,  $y_2 = u(t - \pi) \cos 2t$ . Hence  $y_1$  is continuous at  $\pi$ , whereas  $y_2$  has an upward jump of 1 at that point.

50.  $y_1 = 3e^{4t} + e^{-4t} - 2 \cos 4t + \sin 4t$ ,  $y_2 = 3e^{4t} + e^{-4t} + 2 \cos 4t - \sin 4t$

52.  $0.5q'' + 50q = 1425(1 - u(t - \pi)) \sin 5t$ . The subsidiary equation is

$$\frac{1}{2}s^2Q + 50Q = 1425 \cdot 5 \frac{1 + e^{-\pi s}}{s^2 + 25}.$$

The solution is

$$Q = 14250 \frac{1 + e^{-\pi s}}{(s^2 + 25)(s^2 + 100)} = \frac{14250}{75} (1 + e^{-\pi s}) \left( \frac{1}{s^2 + 25} - \frac{1}{s^2 + 100} \right).$$

The inverse transform is

$$q = -19 \sin 10t + 38 \sin 5t + u(t - \pi) (-19 \sin 10t - 38 \sin 5t).$$

Thus the superposition of two sines terminates at  $t = \pi$ , and  $-38 \sin 10t$  continues thereafter.

54. The system is

$$\begin{aligned} 2i_1' + i_1 - i_2 &= 90e^{-t/4} \\ i_2' - i_1' + 2i_2 &= 0. \end{aligned}$$

The subsidiary equations are

$$2sI_1 + I_1 - I_2 = \frac{90}{s + 1/4}$$

$$sI_2 - 2 - sI_1 + 2I_2 = 0.$$

The solution is

$$I_1 = \frac{184s + 361}{4s^3 + 9s^2 + 6s + 1} = -\frac{59}{(s + 1)^2} - \frac{140}{s + 1} + \frac{140}{s + 1/4}$$

$$I_2 = \frac{8s^2 + 186s + 1}{4s^3 + 9s^2 + 6s + 1} = \frac{59}{(s + 1)^2} + \frac{22}{s + 1} - \frac{20}{s + 1/4}.$$

The inverse transform is

$$i_1 = -(59t + 140)e^{-t} + 140e^{-t/4}$$

$$i_2 = (59t + 22)e^{-t} - 20e^{-t/4}.$$

## Part B LINEAR ALGEBRA. VECTOR CALCULUS

Part B consists of

Chap. 7 Linear Algebra: Matrices, Vectors, Determinants. Linear Systems

Chap. 8 Linear Algebra: Matrix Eigenvalue Problems

Chap. 9 Vector Differential Calculus. Grad, Div, Curl

Chap. 10 Vector Integral Calculus. Integral Theorems.

Hence we have retained the previous subdivision of Part B into four chapters.

Chapter 9 is self-contained and completely independent of Chaps. 7 and 8. Thus, Part B consists of two large **independent** units, namely, Linear Algebra (Chaps. 7, 8) and Vector Calculus (Chaps. 9, 10). Chapter 10 depends on Chap. 9, mainly because of the occurrence of div and curl (defined in Chap. 9) in the Gauss and Stokes theorems in Chap. 10.

### CHAPTER 7 Linear Algebra: Matrices, Vectors, Determinants. Linear Systems

#### Changes

The order of the material in this chapter and its subdivision into sections has been retained, but various local changes have been made to increase the usefulness of this chapter for applications, in particular:

1. The beginning, which was somewhat slow by modern standards, has been streamlined, so that the student will see **applications** to linear systems of equations much earlier.
2. A reference section (Sec. 7.6) on second- and third-order determinants has been included for easier access from other parts of the book.

#### SECTION 7.1. Matrices, Vectors: Addition and Scalar Multiplication, page 272

**Purpose.** Explanation of the basic concepts. Explanation of the two basic matrix operations. The latter derive their importance from their use in defining vector spaces, a fact that should perhaps not be mentioned at this early stage. Its systematic discussion follows in Sec. 7.4, where it will fit nicely into the flow of thoughts and ideas.

#### Main Content, Important Concepts

Matrix, square matrix, main diagonal

Double subscript notation

Row vector, column vector, transposition

Equality of matrices

Matrix addition

Scalar multiplication (multiplication of a matrix by a scalar)

**Comments on Important Facts**

One should emphasize that vectors are always included as special cases of matrices and that those two operations have properties [formulas (3), (4)] similar to those of operations for numbers, which is a great practical advantage.

**SOLUTIONS TO PROBLEM SET 7.1, page 277**

$$2. \begin{bmatrix} 0 & 8 \\ 8 & 16 \\ 4 & 12 \end{bmatrix}, \begin{bmatrix} 12 & 2 \\ -8 & 14 \\ -16 & 6 \end{bmatrix}, \begin{bmatrix} 12 & 10 \\ 0 & 30 \\ -12 & 18 \end{bmatrix}, \begin{bmatrix} 0 & 16 \\ 16 & 32 \\ 8 & 24 \end{bmatrix}$$

$$4. \begin{bmatrix} 6 & -10 & 2 \\ -12 & 8 & 12 \\ 6 & 18 & -8 \end{bmatrix}, \text{ same, } \begin{bmatrix} 15 & 2.5 & 21.5 \\ -2.5 & 9 & 8 \\ 31.5 & 23 & -20 \end{bmatrix}, \text{ undefined}$$

$$6. \text{ Undefined, undefined, } \begin{bmatrix} -72 & -20 & -108 \\ 4 & -40 & -32 \\ -156 & -104 & 96 \end{bmatrix}, \text{ same}$$

$$8. \text{ Undefined, } \begin{bmatrix} -21 \\ 8 \\ 0 \end{bmatrix}, \text{ undefined, undefined}$$

10.  $\frac{1}{5}\mathbf{A}$ ,  $\frac{1}{10}\mathbf{A}$ . Similar (and more important) instances are the scaling of equations in linear systems, the formation of linear combinations, and the like, as will be shown later.
12. 3, 2, -4 and 0, 2, 0. The concept of a main diagonal is restricted to square matrices.
14. No, no, no. Transposition, which relates row and column vectors, will be discussed in the next section.
16. (b). The incidence matrices are as follows, with nodes corresponding to rows and branches to columns, as in Fig. 152.

$$\begin{bmatrix} 1 & 0 & -1 & 1 \\ 0 & 1 & 1 & -1 \\ -1 & -1 & 0 & 0 \end{bmatrix},$$

$$\begin{bmatrix} 1 & 0 & 1 & 0 & 0 \\ -1 & 1 & 0 & 0 & 0 \\ 0 & 0 & 0 & -1 & 1 \\ 0 & -1 & -1 & 1 & -1 \end{bmatrix}, \begin{bmatrix} -1 & 0 & 0 & -1 & 1 & -1 \\ 1 & 1 & 0 & 0 & 0 & 0 \\ 0 & -1 & 1 & 0 & -1 & 1 \\ 0 & 0 & -1 & 1 & 0 & 0 \end{bmatrix}$$

From a figure we may more easily grasp the kind of network. However, in the present context, matrices have two advantages over figures, namely, the computer can handle

them without great difficulties, and a matrix determines a network uniquely, whereas a given network can be drawn as a figure in various ways, so that one does not immediately see that two different figures represent the same network. A nice example is given in Sec. 23.1.

(c) The networks corresponding to the given matrices may be drawn as follows:

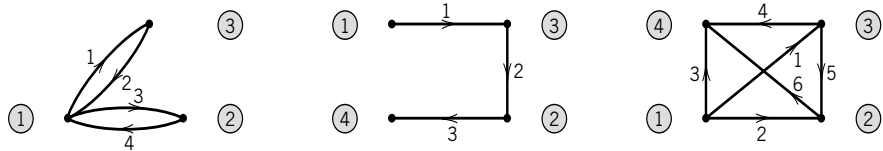

(e) The nodal incidence matrix is

$$\mathbf{A} = \begin{bmatrix} 1 & -1 & -1 & 0 & 0 & 0 \\ 0 & 1 & 0 & 1 & 1 & 0 \\ 0 & 0 & 1 & 0 & -1 & -1 \\ -1 & 0 & 0 & -1 & 0 & 1 \end{bmatrix}.$$

## SECTION 7.2. Matrix Multiplication, page 278

**Purpose.** Matrix multiplication, the third and last algebraic operation, is defined and discussed, with emphasis on its “unusual” properties; this also includes its representation by inner products of row and column vectors.

### Main Content, Important Facts

Definition of matrix multiplication (“rows times columns”)

Properties of matrix multiplication

Matrix products in terms of inner products of vectors

Linear transformations motivating the definition of matrix multiplication

$\mathbf{AB} \neq \mathbf{BA}$  in general, so the order of factors is important.

$\mathbf{AB} = \mathbf{0}$  does not imply  $\mathbf{A} = \mathbf{0}$  or  $\mathbf{B} = \mathbf{0}$  or  $\mathbf{BA} = \mathbf{0}$ .

$(\mathbf{AB})^T = \mathbf{B}^T \mathbf{A}^T$

**Short Courses.** Products in terms of row and column vectors and the discussion of linear transformations could be omitted.

### Comment on Notation

For transposition,  $T$  seems preferable over a prime, which is often used in the literature but will be needed to indicate differentiation in Chap. 9.

### Comments on Content

Most important for the next sections on systems of equations are the multiplication of a matrix times a vector.

Examples 1, 2, and 4 emphasize that matrix multiplication is not commutative and make the student aware of the restrictions of matrix multiplication.

Formula (10d) for the transposition of a product should be memorized.

In motivating matrix multiplication by linear transformations, one may also illustrate the geometric significance of noncommutativity by combining a rotation with a stretch in

$x$ -direction in both orders and show that a circle transforms into an ellipse with main axes in the direction of the coordinate axes or rotated, respectively.

**SOLUTIONS TO PROBLEM SET 7.2, page 286**

2.  $\begin{bmatrix} -3 \\ 50 \\ 54 \end{bmatrix}$ , same,  $\begin{bmatrix} -62 & 34 & 2 \end{bmatrix}$ ,  $\mathbf{0}$  (the  $3 \times 3$  zero matrix)

4.  $\begin{bmatrix} 36 & -16 & -16 \\ 20 & -6 & -22 \\ -20 & 10 & 26 \end{bmatrix}$ ,  $\begin{bmatrix} 113 & 64 & -80 \\ 64 & 65 & -16 \\ -80 & -16 & 137 \end{bmatrix}$ ,  $\begin{bmatrix} 36 & 20 & -20 \\ -16 & -6 & 10 \\ -16 & -22 & 26 \end{bmatrix}$ , same

6. Undefined, undefined,  $\begin{bmatrix} -22 \\ -63 \\ -25 \end{bmatrix}$ ,  $\begin{bmatrix} -22 & -63 & -25 \end{bmatrix}$

8. Undefined,  $-868$ ,  $868$ ,  $\begin{bmatrix} -125 & 300 & 1900 \\ -25 & 60 & 380 \\ -50 & 120 & 760 \end{bmatrix}$

10.  $\begin{bmatrix} 3 & -140 & 92 \\ -24 & -119 & 22 \\ 0 & 94 & -143 \end{bmatrix}$ , same,  $\begin{bmatrix} -77 & -80 & 64 \\ -44 & -71 & -6 \\ 60 & 26 & -111 \end{bmatrix}$

12.  $\begin{bmatrix} 1593 & 900 & -1332 \\ 900 & 711 & -432 \\ -1332 & -432 & 1827 \end{bmatrix}$ ,  $\begin{bmatrix} 11 & 1 \\ 12 & -10 \\ 32 & -4 \end{bmatrix}$ , undefined,  $\begin{bmatrix} 122 & 122 & 348 \\ 122 & 244 & 424 \\ 348 & 424 & 1040 \end{bmatrix}$

14. 538, undefined, undefined, 1690

16.  $\mathbf{M} = \mathbf{AB} - \mathbf{BA}$  must be the  $2 \times 2$  zero matrix. It has the form

$$\begin{aligned} \mathbf{M} &= \begin{bmatrix} a_{11} & a_{12} \\ a_{21} & a_{22} \end{bmatrix} \begin{bmatrix} 2 & 3 \\ 3 & 4 \end{bmatrix} - \begin{bmatrix} 2 & 3 \\ 3 & 4 \end{bmatrix} \begin{bmatrix} a_{11} & a_{12} \\ a_{21} & a_{22} \end{bmatrix} \\ &= \begin{bmatrix} 2a_{11} + 3a_{12} - 2a_{11} - 3a_{21} & 3a_{11} + 4a_{12} - 2a_{12} - 3a_{22} \\ 2a_{21} + 3a_{22} - 3a_{11} - 4a_{21} & 3a_{21} + 4a_{22} - 3a_{12} - 4a_{22} \end{bmatrix}. \end{aligned}$$

$a_{21} = a_{12}$  from  $m_{11} = 0$  (also from  $m_{22} = 0$ ).  $a_{22} = a_{11} + \frac{2}{3}a_{12}$  from  $m_{12} = 0$  (also from  $m_{21} = 0$ ). Answer:

$$\mathbf{A} = \begin{bmatrix} a_{11} & a_{12} \\ a_{12} & a_{11} + \frac{2}{3}a_{12} \end{bmatrix}.$$

18. The calculation for the first column is

$$\begin{bmatrix} 6 & -2 & -2 \\ 10 & -3 & 1 \\ -10 & 5 & 1 \end{bmatrix} \begin{bmatrix} 9 \\ 4 \\ -4 \end{bmatrix} = \begin{bmatrix} 54 \\ 74 \\ -74 \end{bmatrix},$$

and similarly for the other two columns; see the answer to Prob. 1, last matrix given.

20. Idempotent are  $\begin{bmatrix} 1 & 0 \\ 0 & 0 \end{bmatrix}$ ,  $\begin{bmatrix} 1 & 1 \\ 0 & 0 \end{bmatrix}$ , etc.; nilpotent are  $\begin{bmatrix} 0 & a \\ 0 & 0 \end{bmatrix}$ ,  $\begin{bmatrix} 0 & 0 \\ b & 0 \end{bmatrix}$ , etc., and  $\mathbf{A}^2 = \mathbf{I}$  is true for

$$\begin{bmatrix} 1 & 0 \\ 0 & 1 \end{bmatrix}, \begin{bmatrix} -1 & 0 \\ 0 & -1 \end{bmatrix}, \begin{bmatrix} 1 & 0 \\ a & -1 \end{bmatrix}, \begin{bmatrix} -1 & b \\ 0 & 1 \end{bmatrix}, \begin{bmatrix} 0 & c \\ 1/c & 0 \end{bmatrix}$$

where  $a$ ,  $b$ , and  $c \neq 0$  are arbitrary.

22. The entry  $c_{kj}$  of  $(\mathbf{AB})^T$  is  $c_{jk}$  of  $\mathbf{AB}$ , which is Row  $j$  of  $\mathbf{A}$  times Column  $k$  of  $\mathbf{B}$ . On the right,  $c_{kj}$  is Row  $k$  of  $\mathbf{B}^T$ , hence Column  $k$  of  $\mathbf{B}$ , times Column  $j$  of  $\mathbf{A}^T$ , hence Row  $j$  of  $\mathbf{A}$ .
24. An annual increase of about 4–5% because the matrix of this Markov process is

$$\mathbf{A} = \begin{bmatrix} 0.9 & 0.001 \\ 0.1 & 0.999 \end{bmatrix}$$

and the initial state is  $[2000 \ 298000]^T$ , so that multiplication by  $\mathbf{A}$  gives the further states (rounded)  $[2098 \ 297902]^T$ ,  $[2186 \ 297814]^T$ ,  $[2265 \ 297735]^T$ .

26. The transition probabilities can be given in a matrix

$$\mathbf{A} = \begin{array}{cc} & \begin{array}{c} \text{From } N \\ \text{From } T \end{array} \\ \begin{array}{c} \text{To } N \\ \text{To } T \end{array} & \begin{bmatrix} 0.9 & 0.5 \\ 0.1 & 0.5 \end{bmatrix} \end{array}$$

and multiplication of  $[1 \ 0]^T$  by  $\mathbf{A}$ ,  $\mathbf{A}^2$ ,  $\mathbf{A}^3$  gives  $[0.9 \ 0.1]^T$ ,  $[0.86 \ 0.14]^T$ ,  $[0.844 \ 0.156]^T$ . *Answer:* 0.86, 0.844.

28. **Team Project.** (b) Use induction on  $n$ . True if  $n = 1$ . Take the formula in the problem as the induction hypothesis, multiply by  $\mathbf{A}$ , and simplify the entries in the product by the addition formulas for the cosine and sine to get  $\mathbf{A}^{n+1}$ .
- (c) These formulas follow directly from the definition of matrix multiplication.
- (d) A scalar matrix would correspond to a stretch or contraction by the same factor in all directions.
- (e) Rotations about the  $x_1$ -,  $x_2$ -,  $x_3$ -axes through  $\theta$ ,  $\varphi$ ,  $\psi$ , respectively.

### SECTION 7.3. Linear Systems of Equations. Gauss Elimination, page 287

**Purpose.** This simple section centers around the Gauss elimination for solving linear systems of  $m$  equations in  $n$  unknowns  $x_1, \dots, x_n$ , its practical use as well as its mathematical justification (leaving the—more demanding—general existence theory to the next sections).

**Main Content, Important Concepts**

Nonhomogeneous, homogeneous, coefficient matrix, augmented matrix

Gauss elimination in the case of the existence of

- I. a unique solution (Example 2)
- II. infinitely many solutions (Example 3)
- III. no solutions (Example 4).

Pivoting

Elementary row operations, echelon form

**Background Material.** All one needs here is the multiplication of a matrix and a vector.

**Comments on Content**

The student should become aware of the following facts:

1. Linear systems of equations provide a major application of matrix algebra and justification of the definitions of its concepts.

2. The Gauss elimination (with pivoting) gives meaningful results in each of the Cases I–III.

3. This method is a *systematic* elimination that does not look for unsystematic “shortcuts” (depending on the size of the numbers involved and still advocated in some older precomputer-age books).

Algorithms for programs of Gauss’s and related methods are discussed in Sec. 20.1, which is independent of the rest of Chap. 20 and can thus be taken up along with the present section in case of time and interest.

**SOLUTIONS TO PROBLEM SET 7.3, page 295**

2.  $x = -2, y = 1$
4.  $x = 5, y$  arbitrary,  $z = 2y - 1$ . Unknowns that remain arbitrary are sometimes denoted by other letters, such as  $t_1, t_2$ , etc. In the present case we could thus write the solutions as  $x = 5, y = t_1, z = 2t_1 - 1$ .
6.  $x = t_1$  arbitrary,  $y = 3x = 3t_1, z = 2x = 2t_1$
8. No solution
10.  $x = t_1$  arbitrary,  $y = 2x - 5 = 2t_1 - 5, z = 3x + 1 = 3t_1 + 1$
12.  $x = 3z - 1 = 3t_1 - 1, y = -z + 4 = -t_1 + 4, z = t_1$  arbitrary
14.  $w = 2x + 1 = 2t_1 + 1, x = t_1$  arbitrary,  $y = 1, z = 2$
16.  $w = 1, x = t_1$  arbitrary,  $y = 2x - 1 = 2t_1 - 1, z = 3x + 2 = 3t_1 + 2$
18. Currents at the lower node:

$$-I_1 + I_2 + I_3 = 0$$

(minus because  $I_1$  flows out). Voltage in the left circuit:

$$R_1 I_1 + R_2 I_2 = E_1 + E_2$$

and in the right circuit:

$$R_2 I_2 - R_3 I_3 = E_2$$



(minus because  $I_3$  flows against the arrow of  $E_2$ ). *Answer:*

$$I_1 = \frac{1}{D} [(R_2 + R_3)E_1 + R_3E_2]$$

$$I_2 = \frac{1}{D} [R_3E_1 + (R_3 + R_1)E_2]$$

$$I_3 = \frac{1}{D} [R_2E_1 - R_1E_2]$$

where  $D = R_1R_2 + R_2R_3 + R_3R_1$ .

22.  $P_1 = 9, P_2 = 8, D_1 = S_1 = 34, D_2 = S_2 = 38$

24. **Project.** (a) **B** and **C** are different. For instance, it makes a difference whether we first multiply a row and then interchange, and then do these operations in reverse order.

$$\mathbf{B} = \begin{bmatrix} a_{11} & a_{12} \\ a_{31} & a_{32} \\ a_{21} - 5a_{11} & a_{22} - 5a_{12} \\ 8a_{41} & 8a_{42} \end{bmatrix}, \quad \mathbf{C} = \begin{bmatrix} a_{11} & a_{12} \\ a_{31} - 5a_{11} & a_{32} - 5a_{12} \\ a_{21} & a_{22} \\ 8a_{41} & 8a_{42} \end{bmatrix}$$

(b) Premultiplying **A** by **E** (that is, multiplying **A** by **E** from the left) makes **E** operate on *rows* of **A**. The assertions then follow almost immediately from the definition of matrix multiplication.

#### SECTION 7.4. Linear Independence. Rank of a Matrix. Vector Space, page 296

**Purpose.** This section introduces some theory centered around linear independence and rank, in preparation for the discussion of the existence and uniqueness problem for linear systems of equations (Sec. 7.7).

##### Main Content, Important Concepts

- Linear independence
- Real vector space  $R^n$ , dimension, basis
- Rank defined in terms of row vectors
- Rank in terms of column vectors
- Invariance of rank under elementary row operations

**Short Courses.** For the further discussion in the next sections, it suffices to define linear independence and rank.

##### Comments on Rank and Vector Spaces

Of the three possible equivalent definitions of **rank**,

- (i) By row vectors (our definition),
- (ii) By column vectors (our Theorem 3),
- (iii) By submatrices with nonzero determinant (Sec. 7.7),

the first seems to be most practical in our context.

Introducing **vector spaces** here, rather than in Sec. 7.1, we have the advantage that the student immediately sees an application (row and column spaces). Vector spaces in full generality follow in Sec. 7.9.

### SOLUTIONS TO PROBLEM SET 7.4, page 301

2. Row reduction of the matrix and of its transpose gives

$$\begin{bmatrix} 8 & 2 & 5 \\ 0 & 2 & 19 \\ 0 & 0 & 0 \end{bmatrix} \quad \text{and} \quad \begin{bmatrix} 8 & 16 & 4 \\ 0 & 2 & -1 \\ 0 & 0 & 0 \end{bmatrix}.$$

Hence the rank is 2, and bases are  $[8 \ 2 \ 5]$ ,  $[0 \ 2 \ 19]$  and  $[8 \ 16 \ 4]^T$ ,  $[0 \ 2 \ -1]^T$ .

4. Row reduction as in Prob. 2 gives the matrices

$$\begin{bmatrix} a & b & c \\ 0 & \frac{a^2 - b^2}{a} & \frac{c(a - b)}{a} \end{bmatrix} \quad \text{and} \quad \begin{bmatrix} a & b \\ 0 & \frac{c(a - b)}{a} \\ 0 & 0 \end{bmatrix}.$$

Hence for general  $a, b, c$  the rank is 2. Bases are  $[a \ b \ c]$ ,  $[0 \ a^2 - b^2 \ c(a - b)]$  and  $[a \ b]^T$ ,  $[0 \ c(a - b)]^T$ .

6. The matrix is symmetric. The reduction gives

$$\begin{bmatrix} 1 & 1 & a \\ 0 & a - 1 & 1 - a \\ 0 & 0 & 2 - a^2 - a \end{bmatrix}.$$

Hence a basis is  $[1 \ 1 \ a]$ ,  $[0 \ a - 1 \ 1 - a]$ ,  $[0 \ 0 \ 2 - a^2 - a]$  and the transposed vectors (column vectors) for the column space. Hence the rank is 1 (if  $a = 1$ ), 2 (if  $a = -2$ ), and 3 if  $a \neq 1, -2$ .

8. The row reductions as in Prob. 2 give

$$\begin{bmatrix} 1 & -2 & 3 & -4 \\ 0 & 1 & -2 & 7 \\ 0 & 0 & -4 & -4 \\ 0 & 0 & 0 & -40 \end{bmatrix} \quad \text{and} \quad \begin{bmatrix} 1 & 2 & 3 & 4 \\ 0 & 1 & 2 & 7 \\ 0 & 0 & -4 & 4 \\ 0 & 0 & 0 & -40 \end{bmatrix}.$$

The rank is 4, and bases are

$$[1 \ 0 \ 0 \ 0], [0 \ 1 \ 0 \ 0], [0 \ 0 \ 1 \ 0], [0 \ 0 \ 0 \ 1]$$

and the same vectors written as column vectors.

10. The matrix is symmetric. Row reduction gives

$$\begin{bmatrix} 1 & 2 & 3 & 4 \\ 0 & -1 & -2 & -3 \\ 0 & 0 & 0 & 0 \\ 0 & 0 & 0 & 0 \end{bmatrix}.$$

Hence the rank is 2, and bases are  $[1 \ 2 \ 3 \ 4]$ ,  $[0 \ 1 \ 2 \ 3]$  and the same vectors transposed (as column vectors).

12. The matrix is symmetric. Row reduction gives

$$\begin{bmatrix} -7 & 5 & 0 & 2 \\ 0 & 5/7 & 2 & 2/7 \\ 0 & 0 & -7 & 1 \\ 0 & 0 & 0 & 5/7 \end{bmatrix}.$$

Hence the ranks is 4, and bases are

$$[1 \ 0 \ 0 \ 0], [0 \ 1 \ 0 \ 0], [0 \ 0 \ 1 \ 0], [0 \ 0 \ 0 \ 1]$$

and the same vectors written as column vectors.

14. Yes
16. No, by Theorem 4
18. No. Quite generally, if one of the vectors  $\mathbf{v}_{(1)}, \dots, \mathbf{v}_{(m)}$  is  $\mathbf{0}$ , say,  $\mathbf{v}_{(1)} = \mathbf{0}$ , then (1) holds with any  $c_1 \neq 0$  and  $c_2, \dots, c_m$  all zero.
20. No. It is remarkable that  $\mathbf{A} = [a_{jk}]$  with  $a_{jk} = j + k - 1$  has rank 2 for any size  $n$  of the matrix.
22.  $\mathbf{AB}$  and its transpose  $(\mathbf{AB})^T = \mathbf{B}^T \mathbf{A}^T$  have the same rank.
24. This follows directly from Theorem 3.
26. A proof is given in Ref. [B3], Vol. 1, p. 12.
28. Yes if and only if  $k = 0$ . Then the dimension is 3, and a basis is  $[1 \ 0 \ 0 \ 0]$ ,  $[0 \ 3 \ 0 \ 2]$ ,  $[0 \ 0 \ 1 \ 0]$ .
30. No. If  $\mathbf{v} = [v_1 \ v_2]$  satisfies the inequality,  $-\mathbf{v}$  does not. Draw a sketch to see the geometric meaning of the inequality characterizing the “half-plane” above the sloping straight line  $v_2 = v_1$ .
32. Yes, dimension 1, basis  $[1 \ 1 \ 5 \ 0]$
34. No, because of the positivity assumption
36. Yes, dimension 2. The two given equations form a homogeneous linear system with the augmented matrix

$$\begin{bmatrix} 3 & 0 & -1 & 0 & 0 \\ 2 & 3 & 0 & -4 & 0 \end{bmatrix}.$$

The solution is

$$v_1 = -\frac{3}{2}v_2 + 2v_4, \quad v_2 \text{ arbitrary}, \quad v_3 = -\frac{9}{2}v_2 + 6v_4, \quad v_4 \text{ arbitrary}.$$

Taking  $v_2 = -\frac{2}{3}$  and  $v_4 = 0$ , we obtain the basis vector

$$\left[1 \quad -\frac{2}{3} \quad 3 \quad 0\right].$$

Taking  $v_2 = 0$  and  $v_4 = 1$ , we get

$$\left[2 \quad 0 \quad 6 \quad 1\right].$$

Instead of the second vector we could also use

$$\left[0 \quad \frac{4}{3} \quad 0 \quad 1\right]$$

obtained by taking the second vector minus twice the first.

### SECTION 7.5. Solutions of Linear Systems: Existence, Uniqueness, page 302

**Purpose.** The student should see that the totality of solutions (including the existence and uniqueness) can be characterized in terms of the ranks of the coefficient matrix and the augmented matrix.

#### Main Content, Important Concepts

Augmented matrix

Necessary and sufficient conditions for the existence of solutions

Implications for homogeneous systems

$\text{rank } \mathbf{A} + \text{nullity } \mathbf{A} = n$

**Background Material.** Rank (Sec. 7.4)

**Short Courses.** Brief discussion of the first two theorems, illustrated by some simple examples.

#### Comments on Content

This section should make the student aware of the great importance of rank. It may be good to have students memorize the condition

$$\text{rank } \mathbf{A} = \text{rank } \tilde{\mathbf{A}}$$

for the existence of solutions.

Students familiar with ODEs may be reminded of the analog of Theorem 4 (see Sec. 2.7).

This section may also provide a good opportunity to point to the roles of existence and uniqueness problems throughout mathematics (and to the distinction between the two).

### SECTION 7.7. Determinants. Cramer's Rule, page 308

Second- and third-order determinants see in the reference Sec. 7.6.

#### Main Content of This Section

$n$ th-order determinants

General properties of determinants

Rank in terms of determinants (Theorem 3)

Cramer's rule for solving linear systems by determinants (Theorem 4)

**General Comments on Determinants**

Our definition of a determinant seems more practical than that in terms of permutations (because it immediately gives those general properties), at the expense of the proof that our definition is unambiguous (see the proof in App. 4).

General properties are given for order  $n$ , from which they can be easily seen for  $n = 3$  when needed.

The importance of determinants has decreased with time, but determinants will remain in eigenvalue problems (characteristic determinants), ODEs (Wronskians!), integration and transformations (Jacobians!), and other areas of practical interest.

**SOLUTIONS TO PROBLEM SET 7.7, page 314**

6. 1      8.  $-728$       10.  $-27$
12. 0. Together with Prob. 11 this illustrates the theorem that for odd  $n$  the determinant of an  $n \times n$  skew-symmetric matrix has the value 0. This is not generally true for even  $n$ , as Prob. 16 proves.
14. 158
16. 36
18.  $x = 4, y = -3$
20.  $w = 2, x = 5, y = -1, z = -6$
22. 2
24. **Team Project.** (a) Use row operation (subtraction of rows) on  $D$  to transform the last column of  $D$  into the form  $[0 \ 0 \ 1]^T$  and then develop  $D = 0$  by this column. (b) For a plane the equation is  $ax + by + cz + d \cdot 1 = 0$ , so that we get the determinantal equation

$$\begin{vmatrix} x & y & z & 1 \\ x_1 & y_1 & z_1 & 1 \\ x_2 & y_2 & z_2 & 1 \\ x_3 & y_3 & z_3 & 1 \end{vmatrix} = 0.$$

The plane is  $3x + 4y - 2z = 5$ .

(c) For a circle the equation is

$$a(x^2 + y^2) + bx + cy + d \cdot 1 = 0,$$

so that we get

$$\begin{vmatrix} x^2 + y^2 & x & y & 1 \\ x_1^2 + y_1^2 & x_1 & y_1 & 1 \\ x_2^2 + y_2^2 & x_2 & y_2 & 1 \\ x_3^2 + y_3^2 & x_3 & y_3 & 1 \end{vmatrix} = 0.$$

The circle is  $x^2 + y^2 - 4x - 2y = 20$ .

(d) For a sphere the equation is

$$a(x^2 + y^2 + z^2) + bx + cy + dz + e \cdot 1 = 0,$$

so that we obtain

$$\begin{vmatrix} x^2 + y^2 + z^2 & x & y & z & 1 \\ x_1^2 + y_1^2 + z_1^2 & x_1 & y_1 & z_1 & 1 \\ x_2^2 + y_2^2 + z_2^2 & x_2 & y_2 & z_2 & 1 \\ x_3^2 + y_3^2 + z_3^2 & x_3 & y_3 & z_3 & 1 \\ x_4^2 + y_4^2 + z_4^2 & x_4 & y_4 & z_4 & 1 \end{vmatrix} = 0.$$

The sphere through the given points is  $x^2 + y^2 + (z - 1)^2 = 16$ .

(e) For a general conic section the equation is

$$ax^2 + bxy + cy^2 + dx + ey + f \cdot 1 = 0,$$

so that we get

$$\begin{vmatrix} x^2 & xy & y^2 & x & y & 1 \\ x_1^2 & x_1y_1 & y_1^2 & x_1 & y_1 & 1 \\ x_2^2 & x_2y_2 & y_2^2 & x_2 & y_2 & 1 \\ x_3^2 & x_3y_3 & y_3^2 & x_3 & y_3 & 1 \\ x_4^2 & x_4y_4 & y_4^2 & x_4 & y_4 & 1 \\ x_5^2 & x_5y_5 & y_5^2 & x_5 & y_5 & 1 \end{vmatrix} = 0.$$

26.  $\det \mathbf{A}_n = (-1)^{n-1}(n-1)$ . True for  $n = 2$ , a 2-simplex on  $R^1$ , that is, a segment (an interval), because

$$\det \mathbf{A}_2 = (-1)^{2-1}(2-1) = -1.$$

Assume true for  $n$  as just given. Consider  $\mathbf{A}_{n+1}$ . To get the first row with all entries 0, except for the first entry, subtract from Row 1 the expression

$$\frac{1}{n-1} (\text{Row } 2 + \cdots + \text{Row } (n+1)).$$

The first component of the new row is  $-n/(n-1)$ , whereas the other components are all 0. Develop  $\det \mathbf{A}_{n+1}$  by this new first row and notice that you can then apply the above induction hypothesis,

$$\det \mathbf{A}_{n+1} = -\frac{n}{n-1} (-1)^{n-1}(n-1) = (-1)^n n,$$

as had to be shown.

### SECTION 7.8. Inverse of a Matrix. Gauss–Jordan Elimination, page 315

**Purpose.** To familiarize the student with the concept of the inverse  $\mathbf{A}^{-1}$  of a square matrix  $\mathbf{A}$ , its conditions for existence, and its computation.

#### Main Content, Important Concepts

$$\mathbf{A}\mathbf{A}^{-1} = \mathbf{A}^{-1}\mathbf{A} = \mathbf{I}$$

Nonsingular and singular matrices

Existence of  $\mathbf{A}^{-1}$  and rank

Gauss–Jordan elimination

$$(\mathbf{AC})^{-1} = \mathbf{C}^{-1}\mathbf{A}^{-1}$$

Cancellation laws (Theorem 3)

$$\det(\mathbf{AB}) = \det(\mathbf{BA}) = \det \mathbf{A} \det \mathbf{B}$$

**Short Courses.** Theorem 1 without proof, Gauss–Jordan elimination, formulas (4\*) and (7).

### Comments on Content

Although in this chapter we are not concerned with operations count (Chap. 20), it would make no sense to first blindfold the student by using Gauss–Jordan for solving  $\mathbf{Ax} = \mathbf{b}$  and then later in numerics correct the false impression by explaining why Gauss elimination is better because back substitution needs fewer operations than the diagonalization of a triangular matrix. Thus Gauss–Jordan should be applied only when  $\mathbf{A}^{-1}$  is wanted.

The “unusual” properties of matrix multiplication, briefly mentioned in Sec. 7.2 can now be explored systematically by the use of rank and inverse.

Formula (4\*) is worth memorizing.

### SOLUTIONS TO PROBLEM SET 7.8, page 322

2.  $\begin{bmatrix} 0.6 & 0.8 \\ 0.8 & -0.6 \end{bmatrix}$ . This is a symmetric orthogonal matrix. Orthogonal matrices will be discussed in Sec. 8.3, where they will fit much better into the material.

4. The inverse equals the transpose. This is the defining property of orthogonal matrices to be discussed in Sec. 8.3.

6.  $\begin{bmatrix} 4 & -1 & -5 \\ 15 & 1 & -5 \\ 5 & 4 & 9 \end{bmatrix}$

8.  $\begin{bmatrix} 19 & 2 & -9 \\ -4 & -1 & 2 \\ -2 & 0 & 1 \end{bmatrix}$

10.  $\begin{bmatrix} 0 & 0 & \frac{1}{2} \\ \frac{1}{8} & 0 & 0 \\ 0 & \frac{1}{4} & 0 \end{bmatrix}$

12.  $\begin{bmatrix} 11 & 5 & 2 \\ 4 & 2 & -1 \\ 2 & 1 & 0 \end{bmatrix}$

14. Rotation through  $2\theta$ . The inverse represents the rotation through  $-2\theta$ . Replacement of  $2\theta$  by  $-2\theta$  in the matrix gives the inverse.

16.  $\mathbf{I} = (\mathbf{A}^2)^{-1}\mathbf{A}^2$ . Multiply this by  $\mathbf{A}^{-1}$  from the right on both sides of the equation. This gives  $\mathbf{A}^{-1} = (\mathbf{A}^2)^{-1}\mathbf{A}$ . Do the same operation once more to get the formula to be proved.

18.  $\mathbf{I} = \mathbf{I}^T = (\mathbf{A}^{-1}\mathbf{A})^T = \mathbf{A}^T(\mathbf{A}^{-1})^T$ . Now multiply the first and the last expression by  $(\mathbf{A}^T)^{-1}$  from the left, obtaining  $(\mathbf{A}^T)^{-1} = (\mathbf{A}^{-1})^T$ .
20. Multiplication by  $\mathbf{A}$  from the right interchanges Row 1 and Row 2 of  $\mathbf{A}$ , and the inverse of this interchange is the interchange that gives the original matrix back. Hence the inverse of the given matrix should equal the matrix itself, as is the case.
22. For such a matrix (see the solution to Prob. 4) the determinant has either the value 1 or  $-1$ . In the present case it equals  $-1$ . The values of the cofactors (determinants of  $2 \times 2$  matrices times 1 or  $-1$ ) are obtained by straightforward calculation.

### SECTION 7.9. Vector Spaces, Inner Product Spaces, Linear Transformations, *Optional*, page 323

**Purpose.** In this optional section we extend our earlier discussion of vector spaces  $R^n$  and  $C^n$ , define inner product spaces, and explain the role of matrices in linear transformations of  $R^n$  into  $R^m$ .

#### Main Content, Important Concepts

Real vector space, complex vector space

Linear independence, dimension, basis

Inner product space

Linear transformation of  $R^n$  into  $R^m$

**Background Material.** Vector spaces  $R^n$  (Sec. 7.4)

#### Comments on Content

The student is supposed to see and comprehend how concrete models ( $R^n$  and  $C^n$ , the inner product for vectors) lead to abstract concepts, defined by axioms resulting from basic properties of those models. Because of the level and general objective of this chapter, we have to restrict our discussion to the illustration and explanation of the abstract concepts in terms of some simple typical examples.

Most essential from the viewpoint of matrices is our discussion of *linear transformations*, which in a more theoretically oriented course of a higher level would occupy a more prominent position.

#### Comment on Footnote 4

Hilbert's work was fundamental to various areas in mathematics; roughly speaking, he worked on number theory 1893–1898, foundations of geometry 1898–1902, integral equations 1902–1912, physics 1910–1922, and logic and foundations of mathematics 1922–1930. Closest to our interests here is the development in integral equations, as follows. In 1870 Carl Neumann (Sec. 5.6) had the idea of solving the Dirichlet problem for the Laplace equation by converting it to an integral equation. This created general interest in integral equations. In 1896 Vito Volterra (1860–1940) developed a general theory of these equations, followed by Ivar Fredholm (1866–1927) in 1900–1903 (whose papers caused great excitement), and Hilbert since 1902. This gave the impetus to the development of inner product and Hilbert spaces and operators defined on them. These spaces and operators and their spectral theory have found basic applications in quantum mechanics since 1927. Hilbert's great interest in mathematical physics is documented by Ref. [GR3], a classic full of ideas that are of importance to the mathematical work of the engineer. For more details, see G. Birkhoff and E. Kreyszig. The establishment of functional analysis. *Historia Mathematica* **11** (1984), pp. 258–321.



**SOLUTIONS TO PROBLEM SET 7.9, page 329**

2. Yes, dimension 1. A basis vector is obtained by solving the given linear system consisting of the two given conditions. The solution is  $[v_1 \ 3v_1 \ 11v_1]$ ,  $v_1$  arbitrary.  $v_1 = 1$  gives the basis vector  $[1 \ 3 \ 11]^T$ .
4. Yes, dimension 6, basis

$$\begin{bmatrix} 1 & 0 & 0 \\ 0 & 0 & 0 \\ 0 & 0 & 0 \end{bmatrix}, \begin{bmatrix} 0 & 1 & 0 \\ 1 & 0 & 0 \\ 0 & 0 & 0 \end{bmatrix}, \begin{bmatrix} 0 & 0 & 1 \\ 0 & 0 & 0 \\ 1 & 0 & 0 \end{bmatrix},$$

$$\begin{bmatrix} 0 & 0 & 0 \\ 0 & 1 & 0 \\ 0 & 0 & 0 \end{bmatrix}, \begin{bmatrix} 0 & 0 & 0 \\ 0 & 0 & 1 \\ 0 & 1 & 0 \end{bmatrix}, \begin{bmatrix} 0 & 0 & 0 \\ 0 & 0 & 0 \\ 0 & 0 & 1 \end{bmatrix}.$$

6. No, because of the second condition
8. No because  $\det(\mathbf{A} + \mathbf{B}) \neq \det \mathbf{A} + \det \mathbf{B}$  in general
10. Yes, dimension 2, basis  $\cos x$ ,  $\sin x$
12. Yes, dimension 4, basis

$$\begin{bmatrix} 1 & 0 & 0 \\ 0 & 0 & 0 \end{bmatrix}, \begin{bmatrix} 0 & 1 & 0 \\ 0 & 0 & 0 \end{bmatrix}, \begin{bmatrix} 0 & 0 & 1 \\ 0 & 0 & 0 \end{bmatrix}, \begin{bmatrix} 0 & 0 & 0 \\ 4 & 0 & -9 \end{bmatrix}.$$

14. If another such representation with coefficients  $k_j$  would also hold, subtraction would give  $\Sigma(c_j - k_j)\mathbf{a}_j = \mathbf{0}$ ; hence  $c_j - k_j = 0$  because of the linear independence of the basis vectors. This proves the uniqueness.
16.  $x_1 = 0.5y_1 - 0.5y_2$   
 $x_2 = 1.5y_1 - 2.5y_2$
18.  $x_1 = 4y_1 + 2y_3$   
 $x_2 = y_2 + 4y_3$   
 $x_3 = 5y_3$
20.  $x_1 = 0.50y_2 - 0.25y_3$   
 $x_2 = 0.50y_1 + 0.25y_3$   
 $x_3 = -0.25y_1 + 0.25y_2$
22.  $\sqrt{44}$                       24.  $\frac{1}{8}\sqrt{285} = 2.110\ 243$                       26. 1
28.  $2v_1 + v_3 = 0$ ,  $v_3 = -2v_1$ ; hence  $[v_1 \ v_2 \ -2v_1]^T$  with arbitrary  $v_1$  and  $v_2$ . These vectors lie in a plane through the origin whose normal vector is the given vector.
30.  $\mathbf{a} = [4 \ 2 \ -6]^T$ ,  $\mathbf{b} = [16 \ -32 \ 0]^T$ ,  $\mathbf{a} + \mathbf{b} = [20 \ -30 \ -6]^T$ . For the norms we thus obtain

$$\|\mathbf{a} + \mathbf{b}\| = \sqrt{1336} = 36.55 < \|\mathbf{a}\| + \|\mathbf{b}\| = \sqrt{56} + 16\sqrt{5} = 43.26.$$

**SOLUTIONS TO CHAP. 7 REVIEW QUESTIONS AND PROBLEMS, page 330**

12.  $x = 3 - 2y$ ,  $y$  arbitrary,  $z = 0$

14. No solution

16.  $x = 1$ ,  $y = -3$ ,  $z = 5$

18.  $x = -2z$ ,  $y = \frac{1}{4}$ ,  $z$  arbitrary

$$20. \mathbf{AB} = \begin{bmatrix} -52 & 42 & 48 \\ -96 & 34 & -42 \\ -110 & 61 & 18 \end{bmatrix}, \mathbf{BA} = \begin{bmatrix} 52 & 96 & 110 \\ -42 & -34 & -61 \\ -48 & 42 & -18 \end{bmatrix} = -(\mathbf{AB})^T$$

$$22. \mathbf{A}^2 + \mathbf{B}^2 = \begin{bmatrix} 149 & 134 & 212 \\ 134 & 428 & 346 \\ 212 & 346 & 389 \end{bmatrix} + \begin{bmatrix} -40 & 18 & -6 \\ 18 & -13 & -12 \\ -6 & -12 & -45 \end{bmatrix} = \begin{bmatrix} 109 & 152 & 206 \\ 152 & 415 & 334 \\ 206 & 334 & 344 \end{bmatrix}$$

$$24. \mathbf{AA}^T = \mathbf{A}^T\mathbf{A} = \begin{bmatrix} 149 & 134 & 212 \\ 134 & 428 & 346 \\ 212 & 346 & 389 \end{bmatrix}$$

$$26. \mathbf{Aa} = \begin{bmatrix} 49 \\ 142 \\ 109 \end{bmatrix}, \mathbf{a}^T\mathbf{A} = [49 \quad 142 \quad 109], \mathbf{a}^T\mathbf{Aa} = 1250$$

28. 0

$$30. \begin{bmatrix} -20.8 & 16.8 & 19.2 \\ -38.4 & 13.6 & -16.8 \\ -44.0 & 24.4 & 7.2 \end{bmatrix}$$

32. 2, 2. Hence one unknown remains arbitrary.

34. 2, 3. Hence the system has no solution, by Theorem 1 in Sec. 7.5.

36. 2, 2. Hence one unknown remains arbitrary.

$$38. \frac{1}{20} \begin{bmatrix} 2 & -1 & 3 \\ -12 & 6 & -8 \\ 18 & -4 & 12 \end{bmatrix}$$

40. Singular, rank 2

42.  $\text{diag}(\frac{1}{3}, -1, \frac{1}{5})$ 

44. The equations obtained by Kirchhoff's laws are

$$-I_1 - I_2 + I_3 = 0 \quad (\text{Left node})$$

$$50I_1 + 80I_3 = 3800 \quad (\text{Upper loop})$$

$$40I_2 + 80I_3 = 3400 \quad (\text{Lower loop}).$$

This gives the solution  $I_1 = 20$  A,  $I_2 = 15$  A,  $I_3 = 35$  A.

## CHAPTER 8 Linear Algebra: Matrix Eigenvalue Problems

Prerequisite for this chapter is some familiarity with the notion of a matrix and with the two algebraic operations for matrices. Otherwise the chapter is independent of Chap. 7, so that it can be used for teaching eigenvalue problems and their applications, without first going through the material in Chap. 7.

### SECTION 8.1. Eigenvalues, Eigenvectors, page 334

**Purpose.** To familiarize the student with the determination of eigenvalues and eigenvectors of real matrices and to give a first impression of what one can expect (multiple eigenvalues, complex eigenvalues, etc.).

#### Main Content, Important Concepts

Eigenvalue, eigenvector

Determination of eigenvalues from the characteristic equation

Determination of eigenvectors

Algebraic and geometric multiplicity, defect

#### Comments on Content

To maintain undivided attention on the basic concepts and techniques, all the examples in this section are formal, and typical applications are put into a separate section (Sec. 8.2).

The distinction between the algebraic and geometric multiplicity is mentioned in this early section, and the idea of a *basis of eigenvectors* (“**eigenbasis**”) could perhaps be mentioned briefly in class, whereas a thorough discussion of this in a later section (Sec. 8.4) will profit from the increased experience with eigenvalue problems, which the student will have gained at that later time.

The possibility of *normalizing* any eigenvector is mentioned in connection with Theorem 2, but this will be of greater interest to us only in connection with orthonormal or unitary systems (Secs. 8.4 and 8.5).

In our present work we find *eigenvalues* first and are then left with the much simpler task of determining corresponding *eigenvectors*. Numeric work (Secs. 20.6–20.9) may proceed in the opposite order, but to mention this here would perhaps just confuse the student.

### SOLUTIONS TO PROBLEM SET 8.1, page 338

2. The characteristic equation is

$$D(\lambda) = (a - \lambda)(c - \lambda) = 0.$$

Hence  $\lambda_1 = a$ ,  $\lambda_2 = c$ . Components of eigenvectors can now be determined for  $\lambda_1 = a$  from

$$0x_1 + bx_2 = 0, \quad \text{say,} \quad x_1 = 1, \quad x_2 = 0$$

so that an eigenvector is  $[1 \ 0]^T$ , and for  $\lambda_2 = c$  from

$$(a - c)x_1 + bx_2 = 0, \quad \text{say,} \quad x_1 = 1, \quad x_2 = (c - a)/b,$$

so that an eigenvector is

$$\begin{bmatrix} 1 \\ \frac{c - a}{b} \end{bmatrix}^T.$$

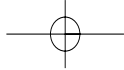

Here we must assume that  $b \neq 0$ . If  $b = 0$ , we have a diagonal matrix with the same eigenvalues as before and eigenvectors  $[1 \ 0]^T$  and  $[0 \ 1]^T$ .

4. This zero matrix, like any square zero matrix, has the eigenvalue 0, whose algebraic multiplicity and geometric multiplicity are both equal to 2, and we can choose any basis, for instance  $[1 \ 0]^T$  and  $[0 \ 1]^T$ .
6. The characteristic equation is

$$(a - \lambda)^2 + b^2 = 0. \quad \text{Solutions are} \quad \lambda = a \pm ib.$$

Eigenvectors are obtained from

$$(a - \lambda)x_1 + bx_2 = \mp ibx_1 + bx_2 = 0.$$

Hence we can take  $x_1 = 1$  and  $x_2 = \pm i$ . Note that  $b$  has dropped out, and the eigenvectors are the same as in Example 4 of the text.

8.  $(\lambda - 1)^2 = 0$ ,  $\lambda = 1$ , any vector is an eigenvector, and  $[1 \ 0]^T$ ,  $[0 \ 1]^T$  is a basis of the eigenspace (the  $x_1x_2$ -plane).
10. The characteristic equation is

$$(\cos \theta - \lambda)^2 + \sin^2 \theta = 0.$$

Solutions (eigenvalues) are  $\lambda = \cos \theta \pm i \sin \theta$ . Eigenvectors are obtained from

$$(\lambda - \cos \theta)x_1 + (\sin \theta)x_2 = (\sin \theta)(\pm ix_1 + x_2) = 0,$$

say,  $x_1 = 1$ ,  $x_2 = \mp i$ .

Note that this matrix represents a rotation through an angle  $\theta$ , and this linear transformation preserves no real direction in the  $x_1x_2$ -plane, as would be the case if the eigenvectors were positive real. This explains why these vectors must be complex.

12.  $-(\lambda^2 - 72\lambda - 2673)\lambda = 0$ ; 0,  $[0 \ 1 \ -1]^T$ ; -27,  $[1 \ 2 \ 2]^T$ ; 99,  $[-22 \ 1 \ 10]^T$
14.  $-(\lambda^3 - 3\lambda^2 - 6\lambda + 8)/(\lambda - 1) = -(\lambda^2 - 2\lambda - 8)$ ; 4,  $[2 \ 1 \ -2]^T$ ; 1,  $[2 \ -2 \ 1]^T$ ; -2,  $[1 \ 2 \ 2]^T$
16. 0.5,  $[1 \ 0 \ 0]^T$ ; 1.0,  $[0.4 \ 1.0 \ 0]^T$ ; 3.5,  $[0.22 \ 1.80 \ 3.00]^T$
18.  $-(\lambda^3 - 9\lambda^2 - 81\lambda + 729)/(\lambda - 9) = -\lambda^2 + 81$ ; 9,  $[2 \ -2 \ 1]^T$ , defect 1; -9,  $[2 \ 1 \ -2]^T$
20. The characteristic equation is

$$\lambda^2(\lambda^2 - 38\lambda + 360) = 0.$$

Eigenvalues and eigenvectors are

$$\begin{aligned} \lambda_1 &= 0, & [0 \ 1 \ 0 \ 0]^T, & [1 \ 0 \ 0 \ 0]^T \\ \lambda_2 &= 18, & [1 \ 1 \ 9 \ 9]^T \\ \lambda_3 &= 20, & [-3 \ 3 \ 5 \ -5]^T. \end{aligned}$$

22. The indicated division of the characteristic polynomial gives

$$(\lambda^4 - 22\lambda^2 + 24\lambda + 45)/(\lambda - 3)^2 = \lambda^2 + 6\lambda + 5.$$

The eigenvalues and eigenvectors are

$$\begin{aligned} \lambda_1 &= 3, & [1 \ 1 \ 1 \ 1]^T & \text{with a defect of 1} \\ \lambda_2 &= -1, & [3 \ -1 \ 1 \ 1]^T \\ \lambda_3 &= -5, & [-11 \ 1 \ 5 \ 1]^T. \end{aligned}$$

24. Using the given eigenvectors, we obtain

$$(\lambda^4 - 118\lambda^2 - 168\lambda + 1485)/[(\lambda - 3)(\lambda + 5)] = \lambda^2 - 2\lambda - 99.$$

The eigenvalues and eigenvectors are

$$\lambda_1 = 11, \quad [-9 \ 7 \ 11 \ -13]^T$$

$$\lambda_2 = 3, \quad [1 \ 1 \ 1 \ 1]^T$$

$$\lambda_3 = -5, \quad [-7 \ -7 \ 13 \ 5]^T$$

$$\lambda_4 = -9, \quad [2 \ -1 \ 2 \ -1]^T$$

30. By Theorem 1 in Sec. 7.8 the inverse exists if and only if  $\det \mathbf{A} \neq 0$ . On the other hand, from the product representation

$$D(\lambda) = \det(\mathbf{A} - \lambda \mathbf{I}) = (-1)^n(\lambda - \lambda_1)(\lambda - \lambda_2) \cdots (\lambda - \lambda_n)$$

of the characteristic polynomial we obtain

$$\det \mathbf{A} = (-1)^n(-\lambda_1)(-\lambda_2) \cdots (-\lambda_n) = \lambda_1\lambda_2 \cdots \lambda_n.$$

Hence  $\mathbf{A}^{-1}$  exists if and only if 0 is not an eigenvalue of  $\mathbf{A}$ .

Furthermore, let  $\lambda \neq 0$  be an eigenvalue of  $\mathbf{A}$ . Then

$$\mathbf{A}\mathbf{x} = \lambda\mathbf{x}.$$

Multiply this by  $\mathbf{A}^{-1}$  from the left:

$$\mathbf{A}^{-1}\mathbf{A}\mathbf{x} = \lambda\mathbf{A}^{-1}\mathbf{x}.$$

Now divide by  $\lambda$ :

$$\frac{1}{\lambda}\mathbf{x} = \mathbf{A}^{-1}\mathbf{x}.$$

## SECTION 8.2. Some Applications of Eigenvalue Problems, page 340

**Purpose.** Matrix eigenvalue problems are of greatest importance in physics, engineering, geometry, etc., and the applications in this section and in the problem set are supposed to give the student at least some impression of this fact.

### Main Content

Applications of eigenvalue problems in

Elasticity theory (Example 1),

Probability theory (Example 2),

Biology (Example 3),

Mechanical vibrations (Example 4).

**Short Courses.** Of course, this section can be omitted, for reasons of time, or one or two of the examples can be considered quite briefly.

### Comments on Content

The examples in this section have been selected from the viewpoint of modest prerequisites, so that not too much time will be needed to set the scene.

Example 4 illustrates why real matrices can have complex eigenvalues (as mentioned before, in Sec. 8.1), and why these eigenvalues are physically meaningful. (For students familiar with systems of ODEs, one can easily pick further examples from Chap. 4.)

**SOLUTIONS TO PROBLEM SET 8.2, page 343**

2.  $(x, y, z)$  is mapped onto  $(x, y, -z)$ . Hence  $[0 \ 0 \ 1]^T$  is an eigenvector corresponding to the eigenvalue  $-1$  of the matrix

$$\mathbf{A} = \begin{bmatrix} 1 & 0 & 0 \\ 0 & 1 & 0 \\ 0 & 0 & -1 \end{bmatrix}.$$

Furthermore,  $\lambda = 1$  is an eigenvalue of  $\mathbf{A}$  of algebraic and geometric multiplicity 2. Two linearly independent eigenvectors are

$$\begin{bmatrix} 1 \\ 0 \\ 0 \end{bmatrix} \quad \text{and} \quad \begin{bmatrix} 0 \\ 1 \\ 0 \end{bmatrix}.$$

4. Sketch the line  $y = x$  in the  $xy$ -plane to see that

$$\begin{aligned} (1, 0, 0) & \text{ maps onto } \left(\frac{1}{2}, \frac{1}{2}, 0\right), \\ (0, 1, 0) & \text{ maps onto } \left(\frac{1}{2}, \frac{1}{2}, 0\right) \end{aligned}$$

and  $(0, 0, 1)$  maps onto itself. Hence the matrix is

$$\begin{bmatrix} \frac{1}{2} & \frac{1}{2} & 0 \\ \frac{1}{2} & \frac{1}{2} & 0 \\ 0 & 0 & 1 \end{bmatrix}.$$

To the eigenvalue 1 there correspond the eigenvectors

$$\begin{bmatrix} 0 \\ 0 \\ 1 \end{bmatrix} \quad \text{and} \quad \begin{bmatrix} 1 \\ 1 \\ 0 \end{bmatrix}$$

which span the plane  $y = x$ . This indicates that every point of this plane is mapped onto itself. For the eigenvalue 0 an eigenvector is  $[1 \ -1 \ 0]^T$ . This shows that any point on the line  $y = -x, z = 0$  (which is perpendicular to the plane  $y = x$ ) is mapped onto the origin.

6.  $(1, 0)$  maps onto  $(0, 1)$ . Also,  $(0, 1)$  maps onto  $(-1, 0)$ . Hence the matrix is

$$\begin{bmatrix} 0 & -1 \\ 1 & 0 \end{bmatrix}.$$

This is the “rotation matrix” in Prob. 10 of Problem Set 8.1 with  $\theta = \pi/2$ . The eigenvalues are  $i$  and  $-i$ . Corresponding eigenvectors are complex, in agreement with the fact that under this rotation, no direction is preserved.

8. Extension by a factor 1.2 (the eigenvalue) in the direction of the eigenvector  $[1 \ 1]^T$  ( $45^\circ$ ). Contraction by  $-0.4$ , direction given by  $[1 \ -1]^T$  ( $-45^\circ$ ). It is typical of a symmetric matrix that the principal directions are orthogonal.
10. Extension by a factor 13 in the direction given by  $[1 \ 2]^T$  ( $63.4^\circ$ ); extension by a factor 3 in the direction given by  $[2 \ -1]^T$  ( $-26.6^\circ$ ).

12. Extension factors  $9 + 2\sqrt{5} = 13.47$  and  $9 - 2\sqrt{5} = 4.53$  in the directions given by  $[1 \quad 2 + \sqrt{5}]^T$  and  $[1 \quad 2 - \sqrt{5}]^T$  ( $76.7^\circ$  and  $-13.3^\circ$ , respectively).
14. Extension factors 11 and 9.5, corresponding to the principal directions  $[1 \quad 1/\sqrt{2}]^T$  ( $35.26^\circ$ ) and  $[-1/\sqrt{2} \quad 1]^T$  ( $144.74^\circ$ ), respectively.
16.  $\mathbf{A}$  has the same eigenvalues as  $\mathbf{A}^T$ , and  $\mathbf{A}^T$  has row sums 1, so that it has the eigenvalue 1 with eigenvector  $\mathbf{x} = [1 \cdots 1]^T$ .

Leontief was a leader in the development and application of quantitative methods in empirical economical research, using genuine data from the economy of the United States to provide, in addition to the “closed model” of Prob. 15 (where the producers consume the whole production), “open models” of various situations of production and consumption, including import, export, taxes, capital gains and losses, etc. See W. W. Leontief, *The Structure of the American Economy 1919–1939* (Oxford: Oxford University Press, 1951); H. B. Cheney and P. G. Clark, *Interindustry Economics* (New York: Wiley, 1959).

18.  $[4 \quad 9]^T$ . Since eigenvectors are determined only up to a nonzero multiplicative constant, this limit vector must be multiplied by a constant such that the sum of its two components equals the sum of the components of the vector representing the initial state.
20. An eigenvector corresponding to the eigenvalue 1 is

$$[121 \quad 132 \quad 176]^T.$$

The other eigenvalues are  $-0.3$  with eigenvector  $[1 \quad 7 \quad -8]^T$  and  $0.4$  with eigenvector  $[1 \quad 0 \quad -1]^T$ . These are not needed here.

22. The growth rate is 3. A corresponding eigenvector is  $[40 \quad 10 \quad 1]^T$ , but is not needed. Neither are the other two eigenvalues 0 with eigenvector  $[0 \quad 0 \quad 1]^T$  and  $-3$  with eigenvector  $[40 \quad -10 \quad 1]^T$ .
24. **Team Project.** (a) This follows by comparing the coefficient of  $\lambda^{n-1}$  in the expansion of  $D(\lambda)$  with that obtained from the product representation.
- (b)  $\mathbf{A}\mathbf{x}_j = \lambda_j\mathbf{x}_j$  ( $\mathbf{x}_j \neq \mathbf{0}$ ),  $(\mathbf{A} - k\mathbf{I})\mathbf{x}_j = \lambda_j\mathbf{x}_j - k\mathbf{x}_j = (\lambda_j - k)\mathbf{x}_j$
- (c) The first statement follows from

$$\mathbf{A}\mathbf{x} = \lambda\mathbf{x}, \quad (k\mathbf{A})\mathbf{x} = k(\mathbf{A}\mathbf{x}) = k(\lambda\mathbf{x}) = (k\lambda)\mathbf{x},$$

the second by induction and multiplication of  $\mathbf{A}^k\mathbf{x}_j = \lambda_j^k\mathbf{x}_j$  by  $\mathbf{A}$  from the left.

(d) From  $\mathbf{A}\mathbf{x}_j = \lambda_j\mathbf{x}_j$  ( $\mathbf{x}_j \neq \mathbf{0}$ ) and (e) follows  $k_p\mathbf{A}^p\mathbf{x}_j = k_p\lambda_j^p\mathbf{x}_j$  and  $k_q\mathbf{A}^q\mathbf{x}_j = k_q\lambda_j^q\mathbf{x}_j$  ( $p \geq 0$ ,  $q \geq 0$ , integer). Adding on both sides, we see that  $k_p\mathbf{A}^p + k_q\mathbf{A}^q$  has the eigenvalue  $k_p\lambda_j^p + k_q\lambda_j^q$ . From this the statement follows.

(e)  $\det(\mathbf{L} - \lambda\mathbf{I}) = -\lambda^3 + l_{12}l_{21}\lambda + l_{13}l_{21}l_{32} = 0$ . Hence  $\lambda \neq 0$ . If all three eigenvalues are real, at least one is positive since  $\text{trace } \mathbf{L} = 0$ . The only other possibility is  $\lambda_1 = a + ib$ ,  $\lambda_2 = a - ib$ ,  $\lambda_3$  real (except for the numbering of the eigenvalues). Then  $\lambda_3 > 0$  because

$$\lambda_1\lambda_2\lambda_3 = (a^2 + b^2)\lambda_3 = \det \mathbf{L} = l_{13}l_{21}l_{32} > 0.$$

### SECTION 8.3. Symmetric, Skew-Symmetric, and Orthogonal Matrices, page 345

**Purpose.** To introduce the student to the three most important classes of real square matrices and their general properties and eigenvalue theory.

**Main Content, Important Concepts**

The eigenvalues of a symmetric matrix are real.

The eigenvalues of a skew-symmetric matrix are pure imaginary or zero.

The eigenvalues of an orthogonal matrix have absolute value 1.

Further properties of orthogonal matrices

**Comments on Content**

The student should memorize the preceding three statements on the locations of eigenvalues as well as the basic properties of orthogonal matrices (orthonormality of row vectors and of column vectors, invariance of inner product, determinant equal to 1 or  $-1$ ).

Furthermore, it may be good to emphasize that, since the eigenvalues of an orthogonal matrix may be complex, so may be the eigenvectors. Similarly for skew-symmetric matrices. Both cases are simultaneously illustrated by

$$\mathbf{A} = \begin{bmatrix} 0 & 1 \\ -1 & 0 \end{bmatrix} \text{ with eigenvectors } \begin{bmatrix} 1 \\ i \end{bmatrix} \text{ and } \begin{bmatrix} 1 \\ -i \end{bmatrix}$$

corresponding to the eigenvalues  $i$  and  $-i$ , respectively.

**SOLUTIONS TO PROBLEM SET 8.3, page 348**

4. Let  $\mathbf{Ax} = \lambda\mathbf{x}$  ( $\mathbf{x} \neq \mathbf{0}$ ),  $\mathbf{Ay} = \mu\mathbf{y}$  ( $\mathbf{y} \neq \mathbf{0}$ ). Then

$$\lambda\mathbf{x}^T = (\mathbf{Ax})^T = \mathbf{x}^T\mathbf{A}^T = \mathbf{x}^T\mathbf{A}.$$

Thus

$$\lambda\mathbf{x}^T\mathbf{y} = \mathbf{x}^T\mathbf{Ay} = \mathbf{x}^T\mu\mathbf{y} = \mu\mathbf{x}^T\mathbf{y}.$$

Hence if  $\lambda \neq \mu$ , then  $\mathbf{x}^T\mathbf{y} = 0$ , which proves orthogonality.

6.  $\det \mathbf{A} = \det (\mathbf{A}^T) = \det (-\mathbf{A}) = (-1)^n \det \mathbf{A} = -\det \mathbf{A} = 0$  if  $n$  is odd. Hence the answer is no. For even  $n = 2, 4, \dots$  we have

$$\begin{bmatrix} 0 & 1 \\ -1 & 0 \end{bmatrix}, \begin{bmatrix} 0 & 1 & 0 & 0 \\ -1 & 0 & 0 & 0 \\ 0 & 0 & 0 & 1 \\ 0 & 0 & -1 & 0 \end{bmatrix}, \text{ etc.}$$

8. Yes, for instance,

$$\begin{bmatrix} 1/2 & \sqrt{3}/2 & 0 \\ \sqrt{3}/2 & -1/2 & 0 \\ 0 & 0 & 1 \end{bmatrix}.$$

10. Symmetric when  $b = 0$ , skew-symmetric when  $a = 0$ , orthogonal when  $a^2 + b^2 = 1$ . Eigenvalues  $a + ib$  and  $a - ib$ . Note that this section concerns *real* matrices.
12. Orthogonal, rotation about the  $z$ -axis through an angle  $\theta$ . Eigenvalues 1 and  $\cos \theta \pm i \sin \theta$
14. Skew-symmetric, eigenvalues 0 and  $\pm 18i$



16. Orthogonal, eigenvalues 1 and

$$\frac{7}{18} \pm \frac{5\sqrt{11}}{18} i$$

all three of absolute value 1

18. See the answer to Prob. 12, above.

20. CAS Experiment.

(a)  $\mathbf{A}^T = \mathbf{A}^{-1}$ ,  $\mathbf{B}^T = \mathbf{B}^{-1}$ ,  $(\mathbf{AB})^T = \mathbf{B}^T \mathbf{A}^T = \mathbf{B}^{-1} \mathbf{A}^{-1} = (\mathbf{AB})^{-1}$ . Also  $(\mathbf{A}^{-1})^T = (\mathbf{A}^T)^{-1} = (\mathbf{A}^{-1})^{-1}$ . In terms of rotations it means that the composite of rotations and the inverse of a rotation are rotations.

(b) The inverse is

$$\begin{bmatrix} \cos \theta & \sin \theta \\ -\sin \theta & \cos \theta \end{bmatrix}.$$

(c) To a rotation of about  $16.26^\circ$ . No limit. For a student unfamiliar with complex numbers this may require some thought.

(d) Limit 0, approach along some spiral.

(e) The matrix is obtained by using familiar values of cosine and sine,

$$\mathbf{A} = \begin{bmatrix} \sqrt{3}/2 & -1/2 \\ 1/2 & \sqrt{3}/2 \end{bmatrix}.$$

#### SECTION 8.4. Eigenbases. Diagonalization. Quadratic Forms, page 349

**Purpose.** This section exhibits the role of bases of eigenvectors (“eigenbases”) in connection with linear transformations and contains theorems of great practical importance in connection with eigenvalue problems.

##### Main Content, Important Concepts

Bases of eigenvectors (Theorems 1, 2)

Similar matrices have the same spectrum (Theorem 3)

Diagonalization of matrices (Theorem 4)

Principal axes transformation of forms (Theorem 5)

**Short Courses.** Complete omission of this section or restriction to a short look at Theorems 1 and 5.

##### Comments on Content

Theorem 1 on similar matrices has various applications in the design of numeric methods (Chap. 20), which often use subsequent similarity transformations to tridiagonalize or (nearly) diagonalize matrices on the way to approximations of eigenvalues and eigenvectors. The matrix  $\mathbf{X}$  of eigenvectors [see (5)] also occurs quite frequently in that context.

Theorem 2 is another result of fundamental importance in many applications, for instance, in those methods for numerically determining eigenvalues and eigenvectors. Its proof is substantially more difficult than the proofs given in this chapter.

**SOLUTIONS TO PROBLEM SET 8.4, page 355**

2. The eigenvalues are  $-8$  and  $8$ . Corresponding eigenvectors are  $[2 \ -1]^T$  and  $[2 \ 1]^T$ , respectively. Thus,

$$\mathbf{X} = \begin{bmatrix} 2 & 2 \\ -1 & 1 \end{bmatrix}.$$

This gives the diagonal matrix  $\mathbf{D} = \text{diag}(-8, 8)$ .

4. The eigenvalues are  $-2$  and  $1$ . Corresponding eigenvectors are  $[2 \ -5]^T$  and  $[1 \ -1]^T$ , respectively. Hence

$$\mathbf{X} = \begin{bmatrix} 2 & 1 \\ -5 & -1 \end{bmatrix}.$$

This gives the diagonal matrix  $\mathbf{D} = \text{diag}(-2, 1)$ .

6. The eigenvalues are  $-12$  and  $5$ . Corresponding eigenvectors are  $[1 \ -2]^T$  and  $[7 \ 3]^T$ , respectively. The diagonal matrix is  $\mathbf{D} = \text{diag}(-12, 5)$ .
8. The eigenvalues are  $4, 0, -2$ . Eigenvectors are  $[1 \ 0 \ 1]^T$ ,  $[1 \ -1 \ 0]^T$ ,  $[0 \ 5 \ 3]^T$ , respectively. Hence

$$\mathbf{X} = \begin{bmatrix} 1 & 1 & 0 \\ 0 & -1 & 5 \\ 1 & 0 & 3 \end{bmatrix}.$$

The diagonal matrix is  $\text{diag}(4, 0, -2)$ .

12. **Project.** (a) This follows immediately from the product representation of the characteristic polynomial of  $\mathbf{A}$ .

(b)  $\mathbf{C} = \mathbf{AB}$ ,  $c_{11} = \sum_{l=1}^n a_{1l}b_{l1}$ ,  $c_{22} = \sum_{l=1}^n a_{2l}b_{l2}$ , etc. Now take the sum of these  $n$  sums. Furthermore, trace  $\mathbf{BA}$  is the sum of

$$\tilde{c}_{11} = \sum_{m=1}^n b_{1m}a_{m1}, \dots, \tilde{c}_{nn} = \sum_{m=1}^n b_{nm}a_{mn}$$

involving the same  $n^2$  terms as those in the double sum of trace  $\mathbf{AB}$ .

(c) By multiplications from the right and from the left we readily obtain

$$\tilde{\mathbf{A}} = \mathbf{P}^2 \hat{\mathbf{A}} \mathbf{P}^{-2}.$$

(d) Interchange the corresponding eigenvectors (columns) in the matrix  $\mathbf{X}$  in (5).

14. We obtain

$$\hat{\mathbf{A}} = \begin{bmatrix} -5 & 0 \\ 24 & 5 \end{bmatrix}.$$

The eigenvalues of  $\hat{\mathbf{A}}$  are  $5$  and  $-5$ . Corresponding eigenvectors are  $[0 \ 1]^T$  and  $[5 \ -12]^T$ , respectively. From this we obtain the eigenvectors  $[2 \ 1]^T$  and  $[1 \ -2]^T$ , respectively, of  $\mathbf{A}$ .

16. We obtain

$$\hat{\mathbf{A}} = \begin{bmatrix} -\frac{2}{5} & \frac{2}{5} \\ \frac{68}{5} & \frac{7}{5} \end{bmatrix}.$$

The eigenvalues of  $\hat{\mathbf{A}}$  are  $-2$  and  $3$ . Corresponding eigenvectors are  $[1 \ -4]^T$  and  $[2 \ 17]^T$ , respectively. From this we obtain the eigenvectors  $[0 \ -15]^T$  and  $[50 \ 70]^T$ , respectively, of  $\mathbf{A}$ .

18. We obtain

$$\hat{\mathbf{A}} = \begin{bmatrix} 4 & 3 & -9 \\ 0 & -5 & 15 \\ 0 & -5 & 15 \end{bmatrix}.$$

The eigenvalues are  $0, 4, 10$ . Corresponding eigenvectors of  $\hat{\mathbf{A}}$  are  $[0 \ 3 \ 1]^T$ ,  $[1 \ 0 \ 0]^T$ ,  $[1 \ -1 \ -1]^T$ , respectively. From these we obtain the eigenvectors  $[3 \ 0 \ 1]^T$ ,  $[0 \ 1 \ 0]^T$ ,  $[-1 \ 1 \ -1]^T$ , respectively, of  $\mathbf{A}$ . These differ from those of  $\hat{\mathbf{A}}$  by an interchange of the first two components. Indeed, this is the effect of  $\mathbf{P}$  under multiplication from the left.

20. The symmetric coefficient matrix is

$$\mathbf{C} = \begin{bmatrix} 3 & 2\sqrt{3} \\ 2\sqrt{3} & 7 \end{bmatrix}.$$

It has the eigenvalues  $9$  and  $1$ . Hence the transformed form is

$$9y_1^2 + y_2^2 = 9.$$

This is an ellipse with semiaxes  $1$  and  $3$ .

The matrix  $\mathbf{X}$  whose columns are normalized eigenvectors of  $\mathbf{C}$  gives the relation between  $\mathbf{y}$  and  $\mathbf{x}$  in the form

$$\mathbf{x} = \begin{bmatrix} 1/2 & -\sqrt{3}/2 \\ \sqrt{3}/2 & 1/2 \end{bmatrix} \mathbf{y}.$$

22. The symmetric coefficient matrix is

$$\mathbf{C} = \begin{bmatrix} 6 & 8 \\ 8 & -6 \end{bmatrix}.$$

It has the eigenvalues  $10$  and  $-10$ . Hence the transformed form is

$$10y_1^2 - 10y_2^2 = 20; \quad \text{thus,} \quad y_1^2 - y_2^2 = 2.$$

This is a hyperbola. The matrix  $\mathbf{X}$  whose columns are normalized eigenvectors of  $\mathbf{C}$  gives the relation between  $\mathbf{y}$  and  $\mathbf{x}$  in the form

$$\mathbf{x} = \begin{bmatrix} 2/\sqrt{5} & 1/\sqrt{5} \\ 1/\sqrt{5} & -2/\sqrt{5} \end{bmatrix} \mathbf{y}.$$

24. The symmetric coefficient matrix of the form is

$$\mathbf{C} = \begin{bmatrix} 7 & -12 \\ -12 & 0 \end{bmatrix}.$$

It has the eigenvalues  $16$  and  $-9$ . Hence the transformed form is

$$16y_1^2 - 9y_2^2 = 144; \quad \text{thus,} \quad y_1^2/9 - y_2^2/16 = 1.$$

This is a hyperbola. The matrix  $\mathbf{X}$  whose columns are normalized eigenvectors of  $\mathbf{C}$  gives the relation between  $\mathbf{y}$  and  $\mathbf{x}$  in the form

$$\mathbf{x} = \begin{bmatrix} 0.8 & 0.6 \\ -0.6 & 0.8 \end{bmatrix} \mathbf{y}.$$

26. The symmetric coefficient matrix is

$$\mathbf{C} = \begin{bmatrix} 3 & 11 \\ 11 & 3 \end{bmatrix}.$$

It has the eigenvalues 14 and  $-8$ . Hence the transformed form is

$$14y_1^2 - 8y_2^2 = 0; \quad \text{thus,} \quad y_2 = \pm(\sqrt{7}/2)y_1.$$

This is a pair of straight lines through the origin. The matrix  $\mathbf{X}$  whose columns are normalized eigenvectors of  $\mathbf{C}$  gives the relation between  $\mathbf{y}$  and  $\mathbf{x}$  in the form

$$\mathbf{x} = \begin{bmatrix} 1/\sqrt{2} & 1/\sqrt{2} \\ 1/\sqrt{2} & -1/\sqrt{2} \end{bmatrix} \mathbf{y}.$$

28. The symmetric coefficient matrix is

$$\mathbf{C} = \begin{bmatrix} 6.5 & 2.5 \\ 2.5 & 6.5 \end{bmatrix}.$$

It has the eigenvalues 9 and 4. Hence the transformed form is

$$9y_1^2 + 4y_2^2 = 36; \quad \text{thus,} \quad y_1^2/4 + y_2^2/9 = 1.$$

This is an ellipse with semiaxes 2 and 3. The matrix  $\mathbf{X}$  whose columns are normalized eigenvectors of  $\mathbf{C}$  gives the relation between  $\mathbf{y}$  and  $\mathbf{x}$  in the form

$$\mathbf{x} = \begin{bmatrix} 1/\sqrt{2} & 1/\sqrt{2} \\ 1/\sqrt{2} & -1/\sqrt{2} \end{bmatrix} \mathbf{y}.$$

30. Transform  $Q(\mathbf{x})$  by (9) to the canonical form (10). Since the inverse transform  $\mathbf{y} = \mathbf{X}^{-1}\mathbf{x}$  of (9) exists, there is a one-to-one correspondence between all  $\mathbf{x} \neq \mathbf{0}$  and  $\mathbf{y} \neq \mathbf{0}$ . Hence the values of  $Q(\mathbf{x})$  for  $\mathbf{x} \neq \mathbf{0}$  coincide with the values of (10) on the right. But the latter are obviously controlled by the signs of the eigenvalues in the three ways stated in the theorem. This completes the proof.

### SECTION 8.5. Complex Matrices and Forms. *Optional*, page 356

**Purpose.** This section is devoted to the three most important classes of complex matrices and corresponding forms and eigenvalue theory.

#### Main Content, Important Concepts

Hermitian and skew-Hermitian matrices

Unitary matrices, unitary systems

Location of eigenvalues (Fig. 161)

Quadratic forms, their symmetric coefficient matrix

Hermitian and skew-Hermitian forms

**Background Material.** Section 8.3, which the present section generalizes. The prerequisites on complex numbers are very modest, so that students will need hardly any extra help in that respect.

**Short Courses.** This section can be omitted.

The importance of these matrices results from quantum mechanics as well as from mathematics itself (e.g., from unitary transformations, product representations of nonsingular matrices  $\mathbf{A} = \mathbf{UH}$ ,  $\mathbf{U}$  unitary,  $\mathbf{H}$  Hermitian, etc.).

The determinant of a unitary matrix (see Theorem 4) may be complex. For example, the matrix

$$\mathbf{A} = \frac{1+i}{\sqrt{2}} \begin{bmatrix} 1 & 0 \\ 0 & 1 \end{bmatrix}$$

is unitary and has

$$\det \mathbf{A} = i.$$

### SOLUTIONS TO PROBLEM SET 8.5, page 361

2.  $(\overline{\mathbf{BA}})^T = (\overline{\mathbf{BA}})^T = \overline{\mathbf{A}^T \mathbf{B}^T} = \mathbf{A}(-\mathbf{B}) = -\mathbf{AB}$ . For the matrices in Example 2,

$$\mathbf{AB} = \begin{bmatrix} 1 + 19i & 5 + 3i \\ -23 + 10i & -1 \end{bmatrix}.$$

4. Eigenvectors are as follows. (Multiplication by a complex constant may change them drastically!)

$$\text{For } \mathbf{A} \quad [1 - 3i \ 5]^T, \quad [1 - 3i \ -2]^T$$

$$\text{For } \mathbf{B} \quad [2 + i \ i]^T, \quad [2 + i \ -5i]^T$$

$$\text{For } \mathbf{C} \quad [1 \ 1]^T, \quad [1 \ -1]^T.$$

6. Skew-Hermitian, eigenvalue  $-2i$  with eigenvector  $[1 \ -1]^T$ ; eigenvalue  $2i$  with eigenvector  $[1 \ 1]^T$ .

8. Skew-Hermitian, unitary, eigenvalues  $i$  and  $-i$ ; corresponding eigenvectors  $[1 \ 1]^T$  and  $[1 \ -1]^T$ , respectively.

10. Hermitian. The eigenvalues and eigenvectors are

$$-2, \quad [i \ -1 - i \ 1]^T$$

$$0, \quad [-i \ 0 \ 1]^T$$

$$2, \quad [i \ 1 + i \ 1]^T.$$

12. **Project.** (a)  $\mathbf{A} = \mathbf{H} + \mathbf{S}$ ,  $\mathbf{H} = \frac{1}{2}(\mathbf{A} + \overline{\mathbf{A}}^T)$ ,  $\mathbf{S} = \frac{1}{2}(\mathbf{A} - \overline{\mathbf{A}}^T)$  ( $\mathbf{H}$  Hermitian,  $\mathbf{S}$  skew-Hermitian)

(b)  $\overline{\mathbf{A}}^T \mathbf{A} = \mathbf{A}^2 = \mathbf{A} \overline{\mathbf{A}}^T$  if  $\mathbf{A}$  is Hermitian,  $\overline{\mathbf{A}}^T \mathbf{A} = -\mathbf{A}^2 = \mathbf{A}(-\mathbf{A}) = \mathbf{A} \overline{\mathbf{A}}^T$  if  $\mathbf{A}$  is skew-Hermitian,  $\overline{\mathbf{A}}^T \mathbf{A} = \mathbf{A}^{-1} \mathbf{A} = \mathbf{I} = \mathbf{A} \mathbf{A}^{-1} = \mathbf{A} \overline{\mathbf{A}}^T$  if  $\mathbf{A}$  is unitary.

(c) We have  $\mathbf{A} = \mathbf{H} + \mathbf{S}$ ,  $\overline{\mathbf{A}}^T = \overline{\mathbf{H}}^T + \overline{\mathbf{S}}^T = \mathbf{H} - \mathbf{S}$ ; hence

$$\mathbf{A} \overline{\mathbf{A}}^T = (\mathbf{H} + \mathbf{S})(\mathbf{H} - \mathbf{S}) = \mathbf{H}^2 - \mathbf{HS} + \mathbf{SH} - \mathbf{S}^2$$

and

$$\overline{\mathbf{A}}^T \mathbf{A} = (\mathbf{H} - \mathbf{S})(\mathbf{H} + \mathbf{S}) = \mathbf{H}^2 + \mathbf{HS} - \mathbf{SH} - \mathbf{S}^2.$$

These two expressions are equal if and only if

$$-\mathbf{HS} + \mathbf{SH} = \mathbf{HS} - \mathbf{SH}; \quad \text{thus,} \quad 2\mathbf{SH} = 2\mathbf{HS},$$

and  $\mathbf{HS} = \mathbf{SH}$ , as claimed.

(d) For instance,

$$\begin{bmatrix} 0 & 0 \\ i & 0 \end{bmatrix}$$

is not normal. A normal matrix that is not Hermitian, skew-Hermitian, or unitary is obtained if we take a unitary matrix and multiply it by 2 or some other real factor different from  $\pm 1$ .

(e) The inverse of a product  $\mathbf{UV}$  of unitary matrices is

$$(\mathbf{UV})^{-1} = \mathbf{V}^{-1}\mathbf{U}^{-1} = \overline{\mathbf{V}}^T \overline{\mathbf{U}}^T = (\overline{\mathbf{UV}})^T.$$

This proves that  $\mathbf{UV}$  is unitary.

We show that the inverse  $\mathbf{A}^{-1} = \mathbf{B}$  of a unitary matrix  $\mathbf{A}$  is unitary. We obtain

$$\mathbf{B}^{-1} = (\mathbf{A}^{-1})^{-1} = (\overline{\mathbf{A}}^T)^{-1} = (\overline{\mathbf{A}^{-1}})^T = \overline{\mathbf{B}}^T,$$

as had to be shown.

14. This form is Hermitian. Its value can be obtained directly by looking at the matrix, namely,

$$\begin{aligned} \overline{\mathbf{x}}^T \mathbf{A} \mathbf{x} &= a\overline{x}_1x_1 + (b + ic)\overline{x}_1x_2 + (b - ic)\overline{x}_2x_1 + k\overline{x}_2x_2 \\ &= a|x_1|^2 + 2\operatorname{Re}[b + ic]\overline{x}_1x_2 + k|x_2|^2. \end{aligned}$$

Here we have used that  $\operatorname{Re} z = \frac{1}{2}(z + \bar{z})$ . Indeed, the two middle terms in the first line on the right are complex conjugates of each other. We also note that the value of the form is real, as it should be for a Hermitian form.

16. Eigenvalues and eigenvectors are

$$\begin{aligned} S_x: & \quad -1, \quad \begin{bmatrix} 1 \\ -1 \end{bmatrix}; \quad 1, \quad \begin{bmatrix} 1 \\ 1 \end{bmatrix} \\ S_y: & \quad -1, \quad \begin{bmatrix} 1 \\ -i \end{bmatrix}; \quad 1, \quad \begin{bmatrix} 1 \\ i \end{bmatrix} \\ S_z: & \quad -1, \quad \begin{bmatrix} 0 \\ 1 \end{bmatrix}; \quad 1, \quad \begin{bmatrix} 1 \\ 0 \end{bmatrix}. \end{aligned}$$

### SOLUTIONS TO CHAP. 8 REVIEW QUESTIONS AND PROBLEMS, page 362

$$10. \mathbf{X}^{-1}\mathbf{A}\mathbf{X} = \begin{bmatrix} 8/65 & 1/65 \\ 1/65 & -8/65 \end{bmatrix} \mathbf{A} \begin{bmatrix} 8 & 1 \\ 1 & -8 \end{bmatrix} = \begin{bmatrix} 13 & 0 \\ 0 & 104 \end{bmatrix}$$

$$12. \mathbf{X}^{-1}\mathbf{A}\mathbf{X} = \frac{1}{9} \begin{bmatrix} 2 & 1 & 0 \\ 0 & -2 & -1 \\ 1 & 0 & 2 \end{bmatrix} \mathbf{A} \begin{bmatrix} 4 & 2 & 1 \\ 1 & -4 & -2 \\ -2 & -1 & 4 \end{bmatrix} = \begin{bmatrix} 18 & 0 & 0 \\ 0 & 9 & 0 \\ 0 & 0 & -9 \end{bmatrix}$$

$$14. \mathbf{X}^{-1}\mathbf{A}\mathbf{X} = \frac{1}{3} \begin{bmatrix} 1 & 1 & -1 \\ 0 & 1 & 1 \\ 1 & -1 & 0 \end{bmatrix} \mathbf{A} \begin{bmatrix} 1 & 1 & 2 \\ 1 & 1 & -1 \\ -1 & 2 & 1 \end{bmatrix} = \begin{bmatrix} 2 & 0 & 0 \\ 0 & 11 & 0 \\ 0 & 0 & -10 \end{bmatrix}$$

$$16. \mathbf{P}^{-1} = \frac{1}{20} \begin{bmatrix} 16 & -8 & 2 \\ -4 & 2 & 2 \\ 2 & 4 & -1 \end{bmatrix}, \hat{\mathbf{A}} = \begin{bmatrix} 15 & 126 & 0 \\ 7 & -6 & 0 \\ -8.5 & -3 & 18 \end{bmatrix}, \lambda = 18, 36, -27$$

From the form of  $\hat{\mathbf{A}}$  it can be seen that one of the eigenvalues is 18, so that the determination of the other two eigenvalues amounts to solving a quadratic equation.

18. The symmetric coefficient matrix is

$$\mathbf{A} = \begin{bmatrix} 11.56 & 10.08 \\ 10.08 & 17.44 \end{bmatrix}.$$

It has the eigenvalues 25 and 4. Hence the form represents the ellipse

$$25y_1^2 + 4y_2^2 = 100; \quad \text{thus,} \quad y_1^2/4 + y_2^2/25 = 1$$

with semiaxes 2 and 5.

20. The symmetric coefficient matrix is

$$\mathbf{A} = \begin{bmatrix} 14 & 12 \\ 12 & -4 \end{bmatrix}.$$

It has the eigenvalues 20 and  $-10$ . Hence the form represents the hyperbola

$$20y_1^2 - 10y_2^2 = 20; \quad \text{thus,} \quad y_1^2 - \frac{1}{2}y_2^2 = 1.$$

## CHAPTER 9 Vector Differential Calculus. Grad, Div, Curl

This chapter is independent of the previous two chapters (7 and 8).

### Changes

The differential–geometric theory of curves in space and in the plane, which in the previous edition was distributed over three consecutive sections, along with its application in mechanics, is now streamlined and shortened and presented in a single section, with a discussion of tangential and normal acceleration in a more concrete fashion.

Formulas for grad, div, and curl in **curvilinear coordinates** are placed for reference in App. A3.4.

### SECTION 9.1. Vector in 2-Space and 3-Space, page 364

**Purpose.** We introduce vectors in 3-space given geometrically by (families of parallel) directed segments or algebraically by ordered triples of real numbers, and we define addition of vectors and scalar multiplication (multiplication of vectors by numbers).

#### Main Content, Important Concepts

Vector, norm (length), unit vector, components

Addition of vectors, scalar multiplication

Vector space  $R^3$ , linear independence, basis

#### Comments on Content

Our discussions in the whole chapter will be independent of Chaps. 7 and 8, and there will be no more need for writing vectors as columns and for distinguishing between row and column vectors. Our notation  $\mathbf{a} = [a_1, a_2, a_3]$  is compatible with that in Chap. 7. Engineers seem to like both notations

$$\mathbf{a} = [a_1, a_2, a_3] = a_1\mathbf{i} + a_2\mathbf{j} + a_3\mathbf{k},$$

preferring the first for “short” components and the second in the case of longer expressions.

The student is supposed to understand that the whole vector algebra (and vector calculus) has resulted from applications, with concepts that are practical, that is, they are “made to measure” for standard needs and situations; thus, in this section, the two algebraic operations resulted from forces (forming resultants and changing magnitudes of forces); similarly in the next sections. The restriction to three dimensions (as opposed to  $n$  dimensions in the previous two chapters) allows us to “visualize” concepts, relations, and results and to give geometrical explanations and interpretations.

On a higher level, the equivalence of the geometric and the algebraic approach (Theorem 1) would require a consideration of how the various triples of numbers for the various choices of coordinate systems must be related (in terms of coordinate transformations) for a vector to have a norm and direction independent of the choice of coordinate systems.

Teaching experience makes it advisable to cover the material in this first section rather slowly and to assign relatively many problems, so that the student gets a feel for vectors in  $R^3$  (and  $R^2$ ) and the interrelation between algebraic and geometric aspects.



**SOLUTION TO PROBLEM SET 9.1, page 370**

2. The components are  $-5, -5, -5$ . The length is  $5\sqrt{3}$ . Hence the unit vector in the direction of  $\mathbf{v}$  is  $[-1/\sqrt{3}, -1/\sqrt{3}, -1/\sqrt{3}]$ .
4.  $v_1 = -2, v_2 = 6, v_3 = 6; |\mathbf{v}| = \sqrt{76}$ . Hence the unit vector in the direction of  $\mathbf{v}$  is  $[-1/\sqrt{19}, 3/\sqrt{19}, 3/\sqrt{19}]$ .
6. Components 6, 8, 10; length  $10\sqrt{2}$ . Unit vector  $[0.6/\sqrt{2}, 0.8/\sqrt{2}, 1/\sqrt{2}]$ .
8.  $Q: (0, 0, 0); |\mathbf{v}| = \sqrt{84}$
10.  $Q: (3, 2, 6), |\mathbf{v}| = 7$ . Note that the given vector is the position vector of  $Q$ .
12.  $Q: (4, 0, 0); |\mathbf{v}| = 3\sqrt{3}$
14.  $[-6, 3, 10]$ . This illustrates (4a).
16.  $[26, -13, -19]$ . This illustrates (4b).
18.  $[2/\sqrt{5}, -1/\sqrt{5}, 0], [0, 0, 1]$ . These are unit vectors.
20.  $5.48 \approx \sqrt{30} < \sqrt{5} + \sqrt{45} \approx 8.94$
24.  $[11, 8, 0]$  is the resultant,  $\sqrt{185} = 13.6$  its magnitude
26. The resultant is  $\mathbf{0}$ . The forces are in equilibrium.
28. Resultant  $[13, 25, 3]$ , magnitude  $\sqrt{803} = 28.3$
30. The  $z$ -component of the resultant is 0 for  $c = -12$ .
32.  $1 \leq |\mathbf{p} + \mathbf{q}| \leq 3$ , nothing about the direction. If this were the arm of some machine or robot, it could not reach the origin but could reach every point of the annulus (ring) indicated. In the next problem the origin can be reached.
34.  $\mathbf{v}_B - \mathbf{v}_A = [-400/\sqrt{2}, 400/\sqrt{2}] - [-500/\sqrt{2}, -500/\sqrt{2}] = [100/\sqrt{2}, 900/\sqrt{2}]$
36. Choose a coordinate system whose axes contain the mirrors. Let  $\mathbf{u} = [u_1, u_2]$  be incident. Then the first reflection gives, say,  $\mathbf{v} = [u_1, -u_2]$ , and the second  $\mathbf{w} = [-u_1, -u_2] = -\mathbf{u}$ . The reflected ray is parallel to the incoming ray, with the direction reversed.
38. **Team Project.** (a) The idea is to write the position vector of the point of intersection  $P$  in two ways and then to compare them, using that  $\mathbf{a}$  and  $\mathbf{b}$  are linearly independent vectors. Thus

$$\lambda(\mathbf{a} + \mathbf{b}) = \mathbf{a} + \mu(\mathbf{b} - \mathbf{a}).$$

$\lambda = 1 - \mu$  are the coefficients of  $\mathbf{a}$  and  $\lambda = \mu$  those of  $\mathbf{b}$ . Together,  $\lambda = \mu = \frac{1}{2}$ , expressing bisection.

(b) The idea is similar to that in part (a). It gives

$$\lambda(\mathbf{a} + \mathbf{b}) = \frac{1}{2}\mathbf{a} + \mu\frac{1}{2}(\mathbf{b} - \mathbf{a}).$$

$\lambda = \frac{1}{2} - \frac{1}{2}\mu$  from  $\mathbf{a}$  and  $\lambda = \frac{1}{2}\mu$  from  $\mathbf{b}$ , resulting in  $\lambda = \frac{1}{4}$ , thus giving a ratio  $(3/4):(1/4) = 3:1$ .

(c) Partition the parallelogram into four congruent parallelograms. Part (a) gives 1:1 for a small parallelogram, hence 1:(1 + 2) for the large parallelogram.

(d)  $\mathbf{v}(P) = \frac{1}{2}\mathbf{a} + \lambda(\mathbf{b} - \frac{1}{2}\mathbf{a}) = \frac{1}{2}\mathbf{b} + \mu(\mathbf{a} - \frac{1}{2}\mathbf{b})$  has the solution  $\lambda = \mu = \frac{1}{3}$ , which gives by substitution  $\mathbf{v}(P) = \frac{1}{3}(\mathbf{a} + \mathbf{b})$  and shows that the third median  $OQ$  passes through  $P$  and  $OP$  equals  $\frac{2}{3}$  of  $|\mathbf{v}(Q)| = \frac{1}{2}|\mathbf{a} + \mathbf{b}|$ , dividing  $OQ$  in the ratio 2:1, too.

(e) In the figure in the problem set,  $\mathbf{a} + \mathbf{b} + \mathbf{c} + \mathbf{d} = \mathbf{0}$ ; hence  $\mathbf{c} + \mathbf{d} = -(\mathbf{a} + \mathbf{b})$ . Also,  $AB = \frac{1}{2}(\mathbf{a} + \mathbf{b})$ ,  $CD = \frac{1}{2}(\mathbf{c} + \mathbf{d}) = -\frac{1}{2}(\mathbf{a} + \mathbf{b})$ , and for  $DC$  we get  $+\frac{1}{2}(\mathbf{a} + \mathbf{b})$ , which shows that one pair of sides is parallel and of the same length. Similarly for the other pair.

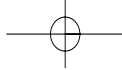

(f) Let  $\mathbf{a}$ ,  $\mathbf{b}$ ,  $\mathbf{c}$  be edge vectors with a common initial point (see the figure). Then the four (space) diagonals have the midpoints

$$AG: \frac{1}{2}(\mathbf{a} + \mathbf{b} + \mathbf{c})$$

$$BH: \mathbf{a} + \frac{1}{2}(\mathbf{b} + \mathbf{c} - \mathbf{a})$$

$$EC: \mathbf{c} + \frac{1}{2}(\mathbf{a} + \mathbf{b} - \mathbf{c})$$

$$DF: \mathbf{b} + \frac{1}{2}(\mathbf{a} + \mathbf{c} - \mathbf{b}),$$

and these four position vectors are equal.

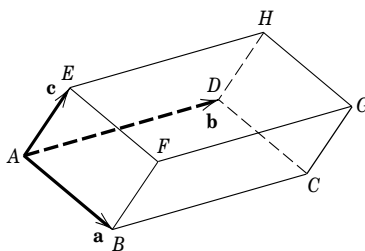

**Section 9.1.** Parallelepiped in Team Project 38(f)

(g) Let  $\mathbf{v}_1, \dots, \mathbf{v}_n$  be the vectors. Their angle is  $\alpha = 2\pi/n$ . The interior angle at each vertex is  $\beta = \pi - (2\pi/n)$ . Put  $\mathbf{v}_2$  at the terminal point of  $\mathbf{v}_1$ , then  $\mathbf{v}_3$  at the terminal point of  $\mathbf{v}_2$ , etc. Then the figure thus obtained is an  $n$ -sided regular polygon, because the angle between two sides equals  $\pi - \alpha = \beta$ . Hence

$$\mathbf{v}_1 + \mathbf{v}_2 + \dots + \mathbf{v}_n = \mathbf{0}.$$

(Of course, for *even*  $n$  the truth of the statement is immediately obvious.)

## SECTION 9.2. Inner Product (Dot Product), page 371

**Purpose.** We define, explain, and apply a first kind of product of vectors, the dot product  $\mathbf{a} \cdot \mathbf{b}$ , whose value is a scalar.

### Main Content, Important Concepts

Definition (1)

Dot product in terms of components

Orthogonality

Length and angle between vectors in terms of dot products

Cauchy–Schwarz and triangle inequalities

### Comment on Dot Product

This product is motivated by work done by a force (Example 2), by the calculation of components of forces (Example 3), and by geometric applications such as those given in Examples 5 and 6.

“Inner product” is more modern than “dot product” and is also used in more general settings (see Sec. 7.9).

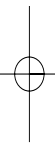

**SOLUTIONS TO PROBLEM SET 9.2, page 376**

2.  $\sqrt{21}$ , 5,  $\sqrt{14}$       4. 12      6. 3      8. 96      10.  $\sqrt{21} < 5 + \sqrt{14}$
12.  $8 < \sqrt{21}\sqrt{14} = 7\sqrt{6} = 17.15$
14.  $\mathbf{u} \cdot (\mathbf{v} - \mathbf{w}) = 0$ ; that is,  $\mathbf{v} - \mathbf{w}$  is orthogonal to  $\mathbf{u}$ . So it does *not* imply that  $\mathbf{v} - \mathbf{w} = \mathbf{0}$ , that is,  $\mathbf{v} = \mathbf{w}$ .
16.  $\mathbf{a} \cdot \mathbf{b} = 4 < 5\sqrt{21}$ ,  $\sqrt{54} = 7.35 < \sqrt{21} + 5 = 9.58$ ,  $54 + 38 = 2(21 + 25) = 92$
18.  $|\mathbf{a} + \mathbf{b}|^2 = (\mathbf{a} + \mathbf{b}) \cdot (\mathbf{a} + \mathbf{b}) \leq |\mathbf{a}|^2 + 2|\mathbf{a}||\mathbf{b}| + |\mathbf{b}|^2 = (|\mathbf{a}| + |\mathbf{b}|)^2$
20.  $[2, 7, -4] \cdot [-3, 1, 0] = 1$
22.  $[4, 3, 6] \cdot [-4, 1, -9] = -67$
24. Let  $\overline{AB} = \mathbf{a}$ . Then  $W = (\mathbf{p} + \mathbf{q}) \cdot \mathbf{a} = \mathbf{p} \cdot \mathbf{a} + \mathbf{q} \cdot \mathbf{a}$ .
26.  $6/\sqrt{42} = 0.9258 = \cos \gamma$ ,  $\gamma = 22.2^\circ$
28.  $7/\sqrt{70} = 0.837 = \cos \gamma$ ,  $\gamma = 33.2^\circ$
30.  $6/\sqrt{54} = 0.6165 = \cos \gamma$ ,  $\gamma = 35.26^\circ$
32.  $|\mathbf{c}|^2 = |\mathbf{a} - \mathbf{b}|^2 = (\mathbf{a} - \mathbf{b}) \cdot (\mathbf{a} - \mathbf{b}) = |\mathbf{a}|^2 + |\mathbf{b}|^2 - 2|\mathbf{a}||\mathbf{b}| \cos \gamma$
34.  $\beta - \alpha$  is the angle between the unit vectors  $\mathbf{a}$  and  $\mathbf{b}$ . Hence (2) gives the result.
36. Hesse's normal form gives  $10/[5, 2, 1] = 10/\sqrt{30} = \sqrt{10/3}$ .
38. 0. The vectors are orthogonal.
40.  $-\sqrt{5}$
42. **Team Project.** (b)  $a_1 = -8/3$
- (c)  $[4, 2] \cdot [5, -10] = 0$
- (d)  $\pm[0.6, -0.8]$
- (e)  $\mathbf{v} \cdot \mathbf{a} = 2v_1 + v_2 = 0$ ; hence  $\mathbf{v} = [v_1, -2v_1, v_3]$ . Yes, of dimension 2.
- (f)  $c = -11.5$
- (g)  $(\mathbf{a} + \mathbf{b}) \cdot (\mathbf{a} - \mathbf{b}) = |\mathbf{a}|^2 - |\mathbf{b}|^2 = 0$ ,  $|\mathbf{a}| = |\mathbf{b}|$ . A square
- (h) Let the mirrors correspond to the coordinate planes. If the ray  $[v_1, v_2, v_3]$  first hits the  $yz$ -plane, then the  $xz$ -plane, and then the  $xy$ -plane, it will be reflected to  $[-v_1, v_2, v_3]$ ,  $[-v_1, -v_2, v_3]$ ,  $[-v_1, -v_2, -v_3]$ ; hence the angle is  $180^\circ$ , the reflected ray will be parallel to the incident ray but will have the opposite direction.
- Corner reflectors have been used in connection with missiles; their aperture changes if the axis of the missile deviates from the tangent direction of the path. See E. Kreyszig, *On the theory of corner reflectors with unequal faces*. Ohio State University: *Antenna Lab Report* 601/19, 1957.

**SECTION 9.3. Vector Product (Cross Product), page 377**

**Purpose.** We define and explain a second kind of product of vectors, the cross product  $\mathbf{a} \times \mathbf{b}$ , which is a vector perpendicular to both given vectors (or the zero vector in some cases).

**Main Content, Important Concepts**

- Definition of cross product, its components (2), (2\*\*)
- Right- and left-handed coordinate systems
- Properties (anticommutative, not associative)
- Scalar triple product

**Prerequisites.** Elementary use of second- and third-order determinants (see Sec. 7.6)

**Comment on Motivations**

Cross products were suggested by the observation that in certain applications, one associates with two given vectors a third vector perpendicular to the given vectors (illustrations in Examples 4–6). Scalar triple products can be motivated by volumes and linear independence (Theorem 2 and Example 6).

**SOLUTIONS TO PROBLEM SET 9.3, page 383**

2.  $[4, -2, -1], \sqrt{21}, 13$
4.  $[-19, 21, -24]$ , since  $\mathbf{d} \times \mathbf{d} = \mathbf{0}$ ,  $[-19, 21, -24]$
6.  $\mathbf{0}$  because of anticommutativity
8.  $\mathbf{0}$  because the two factors are parallel, even equal.
10.  $[50, -30, 0] \neq [54, -27, 10]$ , illustrating nonassociativity
12.  $[2, 4, 46]$
14.  $1, -1$
16.  $-141$
18.  $-108$
20.  $-480, -480$
22. Straightforward calculation. In the first formula, each of the three components is multiplied by  $\ell$ .
24. **Team Project.** (12) is obtained by noting that

$$|\mathbf{a} \times \mathbf{b}|^2 = |\mathbf{a}|^2 |\mathbf{b}|^2 \sin^2 \gamma = |\mathbf{a}|^2 |\mathbf{b}|^2 (1 - \cos^2 \gamma) = (\mathbf{a} \cdot \mathbf{a})(\mathbf{b} \cdot \mathbf{b}) - (\mathbf{a} \cdot \mathbf{b})^2.$$

To prove (13), we choose a right-handed Cartesian coordinate system such that the  $x$ -axis has the direction of  $\mathbf{d}$  and the  $xy$ -plane contains  $\mathbf{c}$ . Then the vectors in (13) are of the form

$$\mathbf{b} = [b_1, b_2, b_3], \quad \mathbf{c} = [c_1, c_2, 0], \quad \mathbf{d} = [d_1, 0, 0].$$

Hence by (2\*\*),

$$\mathbf{c} \times \mathbf{d} = \begin{vmatrix} \mathbf{i} & \mathbf{j} & \mathbf{k} \\ c_1 & c_2 & 0 \\ d_1 & 0 & 0 \end{vmatrix} = -c_2 d_1 \mathbf{k}, \quad \mathbf{b} \times (\mathbf{c} \times \mathbf{d}) = \begin{vmatrix} \mathbf{i} & \mathbf{j} & \mathbf{k} \\ b_1 & b_2 & b_3 \\ 0 & 0 & -c_2 d_1 \end{vmatrix}.$$

The “determinant” on the right equals  $[-b_2 c_2 d_1, b_1 c_2 d_1, 0]$ . Also,

$$\begin{aligned} (\mathbf{b} \cdot \mathbf{d})\mathbf{c} - (\mathbf{b} \cdot \mathbf{c})\mathbf{d} &= b_1 d_1 [c_1, c_2, 0] - (b_1 c_1 + b_2 c_2) [d_1, 0, 0] \\ &= [-b_2 c_2 d_1, b_1 d_1 c_2, 0]. \end{aligned}$$

This proves (13) for our special coordinate system. Now the length and direction of a vector and a vector product, and the value of an inner product, are independent of the choice of the coordinates. Furthermore, the representation of  $\mathbf{b} \times (\mathbf{c} \times \mathbf{d})$  in terms of  $\mathbf{i}, \mathbf{j}, \mathbf{k}$  will be the same for right-handed and left-handed systems, because of the double cross multiplication. Hence, (13) holds in any Cartesian coordinate system, and the proof is complete.

(14) follows from (13) with  $\mathbf{b}$  replaced by  $\mathbf{a} \times \mathbf{b}$ .

To prove (15), we note that  $\mathbf{a} \cdot [\mathbf{b} \times (\mathbf{c} \times \mathbf{d})]$  equals

$$(\mathbf{a} \cdot \mathbf{b})[\mathbf{c} \cdot \mathbf{d}] = (\mathbf{a} \times \mathbf{b}) \cdot (\mathbf{c} \times \mathbf{d})$$

by the definition of the triple product, as well as  $(\mathbf{a} \cdot \mathbf{c})(\mathbf{b} \cdot \mathbf{d}) - (\mathbf{a} \cdot \mathbf{d})(\mathbf{b} \cdot \mathbf{c})$  by (13) (take the dot product by  $\mathbf{a}$ ).

The last formula, (16), follows from familiar rules of interchanging the rows of a determinant.

$$26. [-3, -3, 0] \times [0, 0, 5] = [-15, 15, 0]; \quad 15\sqrt{2}$$

28.  $\mathbf{0}$ ,  $0$ .  $Q$  lies on the line of action of  $\mathbf{p}$ .

$$30. \mathbf{w} \times \mathbf{r} = [5/\sqrt{2}, 5/\sqrt{2}, 0] \times [4, 2, -2] = [-5\sqrt{2}, 5\sqrt{2}, -5\sqrt{2}], \quad |\mathbf{v}| = \sqrt{150}$$

$$32. |[-3, -4, -7] \times [-1, -8, -4]| = |[-40, -5, 20]| = 45$$

$$34. \frac{1}{2}|[0, 3, 0] \times [4, 0, 2]| = \frac{1}{2}|[6, 0, -12]| = \sqrt{45}$$

$$36. [2, 3, 2] \times [-1, 5, -3] = [-19, 4, 13],$$

hence

$$-19x + 4y + 13z = c = -19 \cdot 2 + 4 \cdot 1 + 13 \cdot 3 = 5.$$

38. From the given points we get three edge vectors whose scalar triple product is

$$\begin{vmatrix} 4 & 1 & -1 \\ 6 & 4 & 4 \\ 4 & 5 & 7 \end{vmatrix} = -8.$$

Hence the *answer* is  $8/6 = 4/3$ .

### SECTION 9.4. Vector and Scalar Functions and Fields. Derivatives, page 384

**Purpose.** To get started on vector differential calculus, we discuss vector functions and their continuity and differentiability.

#### Main Content, Important Concepts

Vector and scalar functions and fields

Continuity, derivative of vector functions (9), (10)

Differentiation of dot, cross, and triple products, (11)–(13)

Partial derivatives

#### Comment on Content

This parallels calculus of functions of one variable and can be surveyed quickly.

### SOLUTIONS TO PROBLEM SET 9.4, page 389

2. Parallel straight lines

4. Circles  $\left(x - \frac{1}{2c}\right)^2 + y^2 = \frac{1}{4c^2}$  passing through the origin

6. Hyperbolas  $x^2 - (y - 4)^2 = \text{const}$

**8. CAS Project.** A CAS can graphically handle these more complicated functions, whereas the paper-and-pencil method is relatively limited. This is the point of the project.

Note that all these functions occur in connection with Laplace's equation, so they are real or imaginary parts of complex analytic functions.

10. Elliptic cylinders with vertical generating straight lines
12. Cylinders with cross section  $z = 4y^2 + c$  and generating straight lines parallel to the  $x$ -axis
14. Elliptic paraboloids  $z = x^2 + 4y^2 + c$
16. On horizontal lines  $y = \text{const}$  the  $\mathbf{i}$ -component of  $\mathbf{v}$  is constant, and on vertical lines  $x = \text{const}$  the  $\mathbf{j}$ -component of  $\mathbf{v}$  is constant.
18. At each point the vector  $\mathbf{v}$  equals the corresponding position vector, so that sketching is easy.
20. On  $y = x$  the vector  $\mathbf{v}$  is vertical and on  $y = -x$  it is horizontal.
22. As a curve this is a helix. The first derivative  $[-4 \sin t, 4 \cos t, 2]$  is tangent to this curve, as we shall discuss in the next section, and the second derivative  $[-4 \cos t, -4 \sin t, 0]$  is parallel to the  $xy$ -plane and perpendicular to that tangent.
24.  $[\cos x \cosh y, -\sin x \sinh y], [\sin x \sinh y, \cos x \cosh y]; [e^x \cos y, e^x \sin y], [-e^x \sin y, e^x \cos y]$

### SECTION 9.5. Curves. Arc Length. Curvature. Torsion, page 389

**Purpose.** Discussion of space curves as an application of vector functions of one variable, the use of curves as paths in mechanics (and as paths of integration of line integrals in Chapter 10). Role of parametric representations, interpretation of derivatives in mechanics, completion of the discussion of the foundations of differential-geometric curve theory.

#### Main Content, Important Concepts

Parametric representation (1)  
 Orientation of a curve  
 Circle, ellipse, straight line, helix  
 Tangent vector (7), unit tangent vector (8), tangent (9)  
 Length (10), arc length (11)  
 Arc length as parameter [cf. (14)]  
 Velocity, acceleration (16)–(19)  
 Centripetal acceleration, Coriolis acceleration  
 Curvature, torsion, Frenet formulas (Prob. 50)

**Short Courses.** This section can be omitted.

#### Comment on Problems 26–28

These involve only integrals that are simple (which is generally not the case in connection with lengths of curves).

**SOLUTIONS TO PROBLEM SET 9.5, page 398**

2.  $\mathbf{r}(t) = [5 + 3t, 1 + t, 2 - t]$

4.  $\mathbf{r}(t) = [t, 3 + 2t, 7t]$

6.  $\mathbf{r}(t) = [\cos t, \sin t, \sin t]$

8. Direction of the line of intersection  $[1, 1, -1] \times [2, -5, 1] = [-4, -3, -7]$ . Point of intersection with the  $xy$ -plane  $z = 0$  from  $x + y = 2, 2x - 5y = 3$ ; thus  $x = 13/7, y = 1/7$ . Hence a parametric representation is

$$\mathbf{r}(t) = \left[ \frac{13}{7} - 4t, \frac{1}{7} - 3t, -7t \right].$$

10. Helix  $[3 \cos t, 3 \sin t, 4t]$ 12. Straight line through  $(4, 0, -3)$  in the direction of  $[-2, 8, 5]$ 14. Space curve with projections  $y = x^2, z = x^3$  into the  $xy$ - and  $xz$ -coordinate planes, similar to the curve in Fig. 210.16. Hyperbola  $x^2 - y^2 = 1, z = 0$ 18.  $x = 1, (y - 5)(z + 5) = 1$ ; hyperbola20. No, because the exponential function  $e^t$  is nonnegative.

22.  $\mathbf{r}' = [1, 2t, 0], \mathbf{u} = (1 + 4t^2)^{-1/2}[1, 2t, 0], \mathbf{q} = [2 + w, 4 + 4w, 0]$

24.  $\mathbf{r}'(t) = [-3 \sin t, 3 \cos t, 4], \mathbf{u} = [-0.6 \sin t, 0.6 \cos t, 0.8],$   
 $\mathbf{q} = [3, 3w, 8\pi + 4w]$

26.  $t = 4\pi, \mathbf{r}' = [-2 \sin t, 2 \cos t, 6], \sqrt{\mathbf{r}' \cdot \mathbf{r}'} = \sqrt{40}, \ell = 4\pi\sqrt{40}$

28.  $\mathbf{r}' = [-3a \cos^2 t \sin t, 3a \sin^2 t \cos t]$ . Taking the dot product and applying trigonometric simplification gives

$$\begin{aligned} \mathbf{r}' \cdot \mathbf{r}' &= 9a^2 \cos^4 t \sin^2 t + 9a^2 \sin^4 t \cos^2 t \\ &= 9a^2 \cos^2 t \sin^2 t \\ &= \frac{9a^2}{4} \sin^2 2t. \end{aligned}$$

From this we obtain as the length in the first quadrant

$$\ell = \frac{3}{2} a \int_0^{\pi/2} \sin 2t \, dt = -\frac{3a}{4} (\cos \pi - \cos 0) = \frac{3a}{2}. \quad \text{Answer: } 6a$$

30. We obtain

$$\begin{aligned} ds^2 &= dx^2 + dy^2 \\ &= (d\rho \cos \theta - \rho \sin \theta \, d\theta)^2 + (d\rho \sin \theta + \rho \cos \theta \, d\theta)^2 \\ &= d\rho^2 + \rho^2 \, d\theta^2 \\ &= (\rho'^2 + \rho^2) \, d\theta^2. \end{aligned}$$

For the cardioid,

$$\begin{aligned} \rho^2 + \rho'^2 &= a^2(1 - \cos \theta)^2 + a^2 \sin^2 \theta \\ &= 2a^2(1 - \cos \theta) \\ &= 4a^2 \sin^2 \frac{1}{2}\theta \end{aligned}$$

so that

$$\ell = 2a \int_0^{2\pi} \sin \frac{1}{2}\theta \, d\theta = 8a.$$

$$32. \mathbf{v} = \mathbf{r}' = [4, -3, 0], |\mathbf{v}| = 5, \mathbf{a} = \mathbf{0}$$

$$34. \mathbf{v} = \mathbf{r}' = [-\sin t, 2 \cos t, 0], |\mathbf{v}| = (\sin^2 t + 4 \cos^2 t)^{1/2},$$

$$\mathbf{a} = [-\cos t, -2 \sin t, 0]. \text{ Hence the tangential acceleration is}$$

$$\mathbf{a}_{\text{tan}} = \frac{-3 \sin t \cos t}{\sin^2 t + 4 \cos^2 t} [-\sin t, 2 \cos t, 0]$$

and has the magnitude  $|\mathbf{a}_{\text{tan}}|$ , where

$$|\mathbf{a}_{\text{tan}}|^2 = \frac{9 \sin^2 t \cos^2 t}{\sin^2 t + 4 \cos^2 t}.$$

36. **CAS Project.** (a)  $\mathbf{v} = [-2 \sin t - 2 \sin 2t, 2 \cos t - 2 \cos 2t]$ . From this we obtain  $|\mathbf{v}|^2 = \mathbf{v} \cdot \mathbf{v} = (-2 \sin t - 2 \sin 2t)^2 + (2 \cos t - 2 \cos 2t)^2$ . Performing the squares and simplifying gives

$$\begin{aligned} |\mathbf{v}|^2 &= 8(1 + \sin t \sin 2t - \cos t \cos 2t) \\ &= 8(1 - \cos 3t) \\ &= 16 \sin^2 \frac{3t}{2}. \end{aligned}$$

Hence

$$|\mathbf{v}| = 4 \sin \frac{3t}{2}.$$

$$\mathbf{a} = [-2 \cos t - 4 \cos 2t, -2 \sin t + 4 \sin 2t].$$

We use (18\*). By straightforward simplification (four terms cancel),

$$\begin{aligned} \mathbf{a} \cdot \mathbf{v} &= 12(\cos t \sin 2t + \sin t \cos 2t) \\ &= 12 \sin 3t. \end{aligned}$$

Hence (18\*) gives

$$\mathbf{a}_{\text{tan}} = \frac{12 \sin 3t}{16 \sin^2 (3t/2)} \mathbf{v}$$

$$\mathbf{a}_{\text{norm}} = \mathbf{a} - \mathbf{a}_{\text{tan}}.$$

$$(b) \mathbf{v} = [-\sin t - 2 \sin 2t, \cos t - 2 \cos 2t]$$

$$|\mathbf{v}|^2 = 5 - 4 \cos 3t$$

$$\mathbf{a} = [-\cos t - 4 \cos 2t, -\sin t + 4 \sin 2t]$$

$$\mathbf{a}_{\text{tan}} = \frac{6 \sin 3t}{5 - 4 \cos 3t} [-\sin t - 2 \sin 2t, \cos t - 2 \cos 2t]$$

$$\mathbf{a}_{\text{norm}} = \mathbf{a} - \mathbf{a}_{\text{tan}}$$

$$(c) \mathbf{v} = [-\sin t, 2 \cos 2t, -2 \sin 2t]$$

$$|\mathbf{v}|^2 = 4 + \sin^2 t$$

$$\mathbf{a} = [-\cos t, -4 \sin 2t, -4 \cos 2t]$$

$$\mathbf{a}_{\text{tan}} = \frac{\frac{1}{2} \sin 2t}{4 + \sin^2 t} [-\sin t, 2 \cos 2t, -2 \sin 2t]$$

$$\mathbf{a}_{\text{norm}} = \mathbf{a} - \mathbf{a}_{\text{tan}}$$



$$(d) \mathbf{v} = [c \cos t - ct \sin t, \quad c \sin t + ct \cos t, \quad c]$$

$$|\mathbf{v}|^2 = c^2(t^2 + 2)$$

$$\mathbf{a} = [-2c \sin t - ct \cos t, \quad 2c \cos t - ct \sin t, \quad 0]$$

$$\mathbf{a}_{\text{tan}} = \frac{ct}{t^2 + 2} [\cos t - t \sin t, \quad \sin t + t \cos t, \quad 1]$$

$$\mathbf{a}_{\text{norm}} = \mathbf{a} - \mathbf{a}_{\text{tan}}$$

This is a spiral on a cone.

38.  $\mathbf{R} = 3.85 \cdot 10^8 \text{ m}$ ,  $|\mathbf{v}| = 2\pi R / (2.36 \cdot 10^6) = 1025 \text{ [m/sec]}$ ,  $|\mathbf{v}| = \omega R$ ,  
 $|\mathbf{a}| = \omega^2 R = |\mathbf{v}|^2 / R = 0.0027 \text{ [m/sec}^2\text{]}$ , which is only  $2.8 \cdot 10^{-4} g$ , where  $g$  is the  
acceleration due to gravity at the earth's surface.

40.  $R = 3960 + 450 = 4410 \text{ [mi]}$ ,  $2\pi R = 100|\mathbf{v}|$ ,  $|\mathbf{v}| = 277.1 \text{ mi/min}$ ,

$$g = |\mathbf{a}| = \omega^2 R = |\mathbf{v}|^2 / R = 17.41 \text{ [mi/min}^2\text{]} = 25.53 \text{ [ft/sec}^2\text{]} = 7.78 \text{ [m/sec}^2\text{]}.$$

Here we used  $|\mathbf{v}| = \omega R$ .

42. We denote derivatives with respect to  $t$  by primes. In (22),

$$\mathbf{u} = \frac{d\mathbf{r}}{ds} = \mathbf{r}' \frac{dt}{ds}, \quad \frac{dt}{ds} = \frac{1}{s'} = (\mathbf{r}' \cdot \mathbf{r}')^{-1/2}. \quad [\text{See (12).}]$$

Thus in (22),

$$\frac{d\mathbf{u}}{ds} = \mathbf{r}'' \left( \frac{dt}{ds} \right)^2 + \mathbf{r}' \frac{d^2t}{ds^2} = \mathbf{r}'' (\mathbf{r}' \cdot \mathbf{r}')^{-1} + \mathbf{r}' \frac{d^2t}{ds^2}$$

where

$$\begin{aligned} \frac{d^2t}{ds^2} &= \frac{d}{dt} \left( \frac{dt}{ds} \right) \frac{dt}{ds} = -\frac{1}{2} (\mathbf{r}' \cdot \mathbf{r}')^{-3/2} 2(\mathbf{r}'' \cdot \mathbf{r}') (\mathbf{r}' \cdot \mathbf{r}')^{-1/2} \\ &= -(\mathbf{r}'' \cdot \mathbf{r}') (\mathbf{r}' \cdot \mathbf{r}')^{-2}. \end{aligned}$$

Hence

$$\frac{d\mathbf{u}}{ds} = \mathbf{r}'' (\mathbf{r}' \cdot \mathbf{r}')^{-1} - \mathbf{r}' (\mathbf{r}'' \cdot \mathbf{r}') (\mathbf{r}' \cdot \mathbf{r}')^{-2}$$

$$\begin{aligned} \frac{d\mathbf{u}}{ds} \cdot \frac{d\mathbf{u}}{ds} &= (\mathbf{r}'' \cdot \mathbf{r}') (\mathbf{r}' \cdot \mathbf{r}')^{-2} - 2(\mathbf{r}'' \cdot \mathbf{r}')^2 (\mathbf{r}' \cdot \mathbf{r}')^{-3} + (\mathbf{r}' \cdot \mathbf{r}')^{-3} (\mathbf{r}'' \cdot \mathbf{r}')^2 \\ &= (\mathbf{r}'' \cdot \mathbf{r}') (\mathbf{r}' \cdot \mathbf{r}')^{-2} - (\mathbf{r}'' \cdot \mathbf{r}')^2 (\mathbf{r}' \cdot \mathbf{r}')^{-3}. \end{aligned}$$

Taking square roots, we get (22\*).

44.  $\tau = -\mathbf{p} \cdot (\mathbf{u} \times \mathbf{p})' = -\mathbf{p} \cdot (\mathbf{u}' \times \mathbf{p} + \mathbf{u} \times \mathbf{p}') = 0 - (\mathbf{p} \cdot \mathbf{u} \cdot \mathbf{p}') = +(\mathbf{u} \cdot \mathbf{p} \cdot \mathbf{p}')$ .  
Now  $\mathbf{u} = \mathbf{r}'$ ,  $\mathbf{p} = (1/\kappa)\mathbf{r}''$ ; hence  $\mathbf{p}' = (1/\kappa)\mathbf{r}''' + (1/\kappa)'\mathbf{r}''$ . Inserting this into the  
triple product (the determinant), we can simplify the determinant by familiar rules  
and let the last term in  $\mathbf{p}'$  disappear. Pulling out  $1/\kappa$  from both  $\mathbf{p}$  and  $\mathbf{p}'$ , we obtain  
the second formula in (23\*\*).

46.  $\frac{d\mathbf{r}}{ds} = \frac{d\mathbf{r}}{dt} \bigg/ \frac{ds}{dt}$ ,  $\frac{d^2\mathbf{r}}{ds^2} = \frac{d^2\mathbf{r}}{dt^2} \bigg/ \left( \frac{ds}{dt} \right)^2 + \dots$ ,

$$\frac{d^3\mathbf{r}}{ds^3} = \frac{d^3\mathbf{r}}{dt^3} \bigg/ \left( \frac{ds}{dt} \right)^3 + \dots$$

where the dots denote terms that vanish by applying familiar rules for simplifying determinants; thus

$$\tau = \frac{1}{\kappa^2} \begin{vmatrix} \frac{d\mathbf{r}}{ds} & \frac{d^2\mathbf{r}}{ds^2} & \frac{d^3\mathbf{r}}{ds^3} \end{vmatrix} = \frac{1}{\kappa^2(ds/dt)^6} \begin{vmatrix} \frac{d\mathbf{r}}{dt} & \frac{d^2\mathbf{r}}{dt^2} & \frac{d^3\mathbf{r}}{dt^3} \end{vmatrix}.$$

Now use (22\*) and (12).

48. From  $\mathbf{r}(t) = [a \cos t, a \sin t, ct]$  we obtain

$$\mathbf{r}' = [-a \sin t, a \cos t, c], \quad \mathbf{r}' \cdot \mathbf{r}' = a^2 + c^2 = K^2.$$

Hence by integration,  $s = Kt$ . Consequently,  $t = s/K$ . This gives the indicated representation of the helix with arc length  $s$  as parameter. Denoting derivatives with respect to  $s$  also by primes, we obtain

$$\mathbf{r}(s) = \left[ a \cos \frac{s}{K}, a \sin \frac{s}{K}, \frac{cs}{K} \right], \quad K^2 = a^2 + c^2$$

$$\mathbf{u}(s) = \mathbf{r}'(s) = \left[ -\frac{a}{K} \sin \frac{s}{K}, \frac{a}{K} \cos \frac{s}{K}, \frac{c}{K} \right]$$

$$\mathbf{r}''(s) = \left[ -\frac{a}{K^2} \cos \frac{s}{K}, -\frac{a}{K^2} \sin \frac{s}{K}, 0 \right]$$

$$\kappa(s) = |\mathbf{r}''| = \sqrt{\mathbf{r}'' \cdot \mathbf{r}''} = \frac{a}{K^2} = \frac{a}{a^2 + c^2}$$

$$\mathbf{p}(s) = \frac{1}{\kappa(s)} \mathbf{r}''(s) = \left[ -\cos \frac{s}{K}, -\sin \frac{s}{K}, 0 \right]$$

$$\mathbf{b}(s) = \mathbf{u}(s) \times \mathbf{p}(s) = \left[ \frac{c}{K} \sin \frac{s}{K}, -\frac{c}{K} \cos \frac{s}{K}, \frac{a}{K} \right]$$

$$\mathbf{b}'(s) = \left[ \frac{c}{K^2} \cos \frac{s}{K}, \frac{c}{K^2} \sin \frac{s}{K}, 0 \right]$$

$$\tau(s) = -\mathbf{p}(s) \cdot \mathbf{b}'(s) = \frac{c}{K^2} = \frac{c}{a^2 + c^2}.$$

Positive  $c$  gives a right-handed helix and positive torsion; negative  $c$  gives a left-handed helix and negative torsion.

50.  $\mathbf{p}' = (1/\kappa)\mathbf{u}'$  implies the first formula,  $\mathbf{u}' = \kappa\mathbf{p}$ . The third Frenet formula was given in the text before (23). To obtain the second Frenet formula, use

$$\mathbf{p}' = (\mathbf{b} \times \mathbf{u})' = \mathbf{b}' \times \mathbf{u} + \mathbf{b} \times \mathbf{u}' = -\tau \mathbf{p} \times \mathbf{u} + \mathbf{b} \times \kappa\mathbf{p} = +\tau\mathbf{b} - \kappa\mathbf{u}.$$

In differential geometry (see Ref. [GR8] in App. 1) it is shown that the whole differential-geometric theory of curves can be obtained from the Frenet formulas, whose solution shows that the “natural equations”  $\kappa = \kappa(s)$ ,  $\tau = \tau(s)$  determine a curve uniquely, except for its position in space.

### SECTION 9.6. Calculus Review: Functions of Several Variables. *Optional*, page 400

**Purpose.** To give students a handy reference and some help on material known from calculus that they will need in their further work.

**SOLUTIONS TO PROBLEM SET 9.6, page 403**

2.  $w' = (h/g)' = (h'g - g'h)/g^2$

4.  $x' = -2 \sin t$ ,  $y' = 2 \cos t$ ,  $z' = 5$ , so that by the chain rule

$$\begin{aligned} w' &= (y+z)(-2 \sin t) + (z+x)2 \cos t + (x+y) \cdot 5 \\ &= (2 \sin t + 5t)(-2 \sin t) + (2 \cos t + 5t)2 \cos t \\ &\quad + (2 \cos t + 2 \sin t) \cdot 5 \\ &= 4 \cos 2t + 10[(t+1) \cos t + (-t+1) \sin t]. \end{aligned}$$

6.  $\partial w/\partial u = -24u + 32v$ ,  $\partial w/\partial v = 32u + 24v$

8.  $\partial w/\partial u = 4u^3(v^4 - 4 + v^{-4})$ ,  $\partial w/\partial v = 4u^4(v^3 - v^{-5})$

10. This follows from (1). *Answer:*

$$\partial \tilde{w}/\partial x = 3x^2 + 2(x^2 + y^2)2x, \quad \partial \tilde{w}/\partial y = 3y^2 + 2(x^2 + y^2)2y.$$

**SECTION 9.7. Gradient of a Scalar Field. Directional Derivative, page 403**

**Purpose.** To discuss gradients and their role in connection with directional derivatives, surface normals, and the generation of vector fields from scalar fields (potentials).

**Main Content, Important Concepts**

Gradient, nabla operator

Directional derivative, maximum increase, surface normal

Vector fields as gradients of potentials

Laplace's equation

**Comments on Content**

This is probably the first section in which one should no longer rely on knowledge from calculus, although relatively elementary calculus books usually include a passage on gradients.

Potentials are important; they will occur at a number of places in our further work.

**SOLUTIONS TO PROBLEM SET 9.7, page 409**

2.  $\nabla f = [2x, \frac{2}{9}y]$

4.  $\nabla f = [4x^3, 4y^3]$

6.  $\nabla f = [2x - 6, 2y - 2]$

8.  $\mathbf{v} = \nabla f = (x^2 + y^2)^{-1}[2x, 2y]$ ,  $\mathbf{v}(P) = [0.32, 0.24]$

10.  $\mathbf{v} = \nabla f = [2x, 8y, 18z]$ ,  $\mathbf{v}(P) = [6, 16, 18]$

12.  $\mathbf{v} = \nabla f = (x^2 + y^2 + z^2)^{-3/2}[-x, -y, -z]$ ,  $\mathbf{v}(P) = [-2/27, -1/27, -2/27]$

14.  $\nabla T = (x^2 + y^2)^{-1}[-y, x]$ ,  $-\nabla T(P) = [0.25, -0.25]$

16.  $\nabla T = (x^2 + y^2)^{-2}[y^2 - x^2, -2xy]$ ,  $-\nabla T(P) = [1/16, 0]$

18.  $\nabla T = [\cos x \cosh y, \sin x \sinh y]$ ,  $-\nabla T(P) = [-2.6/\sqrt{2}, -2.4/\sqrt{2}]$

20.  $\nabla f = (x^2 + y^2)^{-2}[-2xy, x^2 - y^2]$ ,  $\nabla f(P) = [-15/578, 4/289]$

22.  $\nabla f = (x^2 + y^2)^{-1}[2x, 2y]$ ,  $\nabla f(P) = [1/3, 1/3]$

24.  $\nabla f = [2xy, x^2 - y^2]$ ,  $\nabla f(P) = [12, -5]$

26.  $\nabla z = [-8x, -2y]$ ,  $\nabla z(P) = [-24, 12]$ . Hence a vector in the direction of steepest ascent is  $[-2, 1]$ , for instance.

28. A normal vector is  $[2x, 6y, 2z]$ . Its value at  $P$  is  $[8, 6, 6]$ .
30. A normal vector is  $[2x, -2y, 8z]$ . Its value at  $P$  is  $[-4, -2, 32]$ .
32. A normal vector is  $[-2x, -2y, 1]$ . Its value at  $P$  is  $[-6, -8, 1]$ .
34.  $\nabla f = [2x, 2y, 2z]$ ,  $\nabla f(P) = [4, -4, 2]$ ,  $\nabla f(P) \cdot \mathbf{a} = 0$ . This shows that  $\mathbf{a}$  is tangent to the level surface  $f(x, y, z) = 9$  through  $P$ .
36.  $\nabla f = -(x^2 + y^2 + z^2)^{-3/2}[x, y, z]$ ,  $\nabla f(P) = -(1/216)[4, 2, -4]$ . Hence the directional derivative is

$$-(1/216)[1, 2, -2] \cdot [4, 2, -4]/3 = -2/81 = -0.02469.$$

38.  $\nabla f = [8x, 2y, 18z]$ ,  $\nabla f(P) = [16, 8, 0]$ . Hence the directional derivative is
- $$[16, 8, 0] \cdot [-2, -4, 3]/\sqrt{29} = -64/\sqrt{29} = -11.88.$$

40.  $f = ye^x + z^2$

42. **Project.** The first formula follows from

$$[(fg)_x, (fg)_y, (fg)_z] = [f_x g, f_y g, f_z g] + [f g_x, f g_y, f g_z].$$

The second formula follows by the chain rule, and the third follows by applying the quotient rule to each of the components  $(f/g)_x, (f/g)_y, (f/g)_z$  and suitably collecting terms. The last formula follows by two applications of the product rule to each of the three terms of  $\nabla^2$ .

## SECTION 9.8. Divergence of a Vector Field, page 410

**Purpose.** To explain the divergence (the second of the three concepts grad, div, curl) and its physical meaning in fluid flows.

### Main Content, Important Concepts

Divergence of a vector field

Continuity equations (5), (6)

Incompressibility condition (7)

### Comment on Content

The interpretation of the divergence in Example 2 depends essentially on our assumption that there are no sources or sinks in the box. From our calculations it becomes plausible that in the case of sources or sinks the divergence may be related to the net flow across the boundary surfaces of the box. To confirm this and to make it precise we need integrals; we shall do this in Sec. 10.8 (in connection with Gauss's divergence theorem).

### Moving div and curl to Chap. 10?

Experimentation has shown that this would perhaps not be a good idea, simply because it would combine two substantial difficulties, that of understanding div and curl themselves, and that of understanding the nature and role of the two basic integral theorems by Gauss and Stokes, in which div and curl play the key role.

## SOLUTIONS TO PROBLEM SET 9.8, page 413

2.  $\operatorname{div} \mathbf{v} = 4e^{2x} \cos 2y + 10e^{2z}$
4.  $\operatorname{div} \mathbf{v} = 0$
6.  $\operatorname{div} \mathbf{v} = 0$ . This follows immediately by noting that  $v_1, v_2, v_3$  does not depend on  $x, y, z$ , respectively.

8.  $\operatorname{div} \mathbf{v} = 2 + \frac{\partial v_3}{\partial z}$ . Of course, there are many ways of satisfying the conditions. For instance, (a)  $v_3 = 0$ , (b)  $v_3 = -z - \frac{1}{3}z^3$ . The point of the problem is that the student gets used to the definition of the divergence and recognizes that  $\operatorname{div} \mathbf{v}$  can have different values and also the sign can differ in different regions of space.

10.  $\mathbf{v} = v_1\mathbf{i} + v_2\mathbf{j} + v_3\mathbf{k} = \frac{dx}{dt}\mathbf{i} + \frac{dy}{dt}\mathbf{j} + \frac{dz}{dt}\mathbf{k} = x\mathbf{i}$ . Hence  $\operatorname{div} \mathbf{v} = 1$ , and

$$\frac{dx}{dt} = x, \quad \frac{dy}{dt} = 0, \quad \frac{dz}{dt} = 0.$$

By integration,  $x = c_1e^t$ ,  $y = c_2$ ,  $z = c_3$ , and  $\mathbf{r} = x\mathbf{i} + y\mathbf{j} + z\mathbf{k}$ . Hence

$$\mathbf{r}(0) = c_1\mathbf{i} + c_2\mathbf{j} + c_3\mathbf{k} \quad \text{and} \quad \mathbf{r}(1) = c_1e\mathbf{i} + c_2\mathbf{j} + c_3\mathbf{k}.$$

This shows that the cube in Prob. 9 is now transformed into the rectangular parallelepiped bounded by  $x = 0$ ,  $x = e$ ,  $y = 0$ ,  $y = 1$ ,  $z = 0$ ,  $z = 1$ , whose volume is  $e$ .

12. (a) Parallel flow

(b) Outflow on the left and right, no flow across the other sides; hence  $\operatorname{div} \mathbf{v} > 0$ .

(c) Outflow left and right, inflow from above and below, balance perhaps zero; by calculation,  $\operatorname{div} \mathbf{v} = 0$ . Etc.

14.  $6xy/z^4$

16.  $-4/\sqrt{x^2 + y^2}$  by straightforward simplification

18. 0

20.  $2(\sin^2 x - \cos^2 x - \cos^2 y + \sin^2 y) = -2(\cos 2x + \cos 2y)$

## SECTION 9.9. Curl of Vector Field, page 414

### Purpose

We introduce the curl of a vector field (the last of the three concepts grad, div, curl) and interpret it in connection with rotations (Example 2 and Theorem 1). A main application of the curl follows in Sec. 10.9 in Stokes's integral theorem.

Experience has shown that it is generally didactically preferable to defer Stokes's theorem to a later section and first to give the student a feel for the curl independent of an integral theorem.

### Main Content

Definition of the curl (1)

Curl and rotations (Theorem 1)

Gradient fields are irrotational (Theorem 2)

Irrotational fields, conservative fields

## SOLUTIONS TO PROBLEM SET 9.9, page 416

2.  $-n[z^{n-1}, x^{n-1}, y^{n-1}]$

4.  $\operatorname{curl} \mathbf{v} = \mathbf{0}$ . Recall from Theorem 3 in Sec. 9.7 with  $\mathbf{r}_0 = \mathbf{0}$  and  $x^2 + y^2 + z^2 = r^2$  that the present vector field is a gradient field, so that we must have  $\operatorname{curl} \mathbf{v} = \mathbf{0}$ .

6.  $\text{curl } \mathbf{v} = [\sin z, \tan^2 x + 1, -\cos y]$   
 8. A proof follows by calculation directly from the definitions.  
 10.  $\text{curl } \mathbf{v} = [0, 0, 2y]$ ,  $\text{div } \mathbf{v} = 0$ , incompressible; paths are obtained as follows. We have

$$\mathbf{v} = \mathbf{r}' = [x', y', z'] = [-y^2, 4, 0].$$

Equating components gives

$$z' = 0, \quad z = c_3, \quad y' = 4, \quad y = 4t + c_2, \quad x' = -y^2$$

and by substitution of  $y$

$$x' = -(4t + c_2)^2; \quad \text{hence} \quad x = -\frac{1}{12}(4t + c_2)^3 + c_1.$$

12.  $\text{curl } \mathbf{v} = [0, 0, \sec x \tan x]$ ,  $\text{div } \mathbf{v} = -\csc x \cot x$ . The paths are obtained from

$$\mathbf{v} = [x', y', z'] = [\csc x, \sec x, 0].$$

Equating the first components gives

$$x' = \csc x, \quad \sin x \, dx = dt, \quad -\cos x = t - c_1;$$

hence  $x = -\arccos(t - c_1)$ .

By comparing the second components we obtain

$$y' = \sec x = \frac{1}{\cos x} = \frac{1}{c_1 - t}, \quad y = -\ln(c_1 - t) + c_2.$$

Finally, for the third components we have  $z' = 0$ ,  $z = c_3$ . Our solution contains enough arbitrary constants to accommodate individual particles with a corresponding path.

14.  $\text{curl } \mathbf{v} = [0, 0, -3x^2 - 3y^2]$ ,  $\text{div } \mathbf{v} = 0$ , incompressible. The paths are obtained by the following calculation.

$$\begin{aligned} x' &= y^3, & y' &= -x^3, & x^3 \, dx + y^3 \, dy &= 0, \\ x^4 + y^4 &= c, & z &= c_3. \end{aligned}$$

Each of these closed curves lies in the plane  $z = c_3$  between the square of side  $2c^{1/4}$  symmetrically located with respect to the origin and the circle of radius  $c^{1/4}$  and center  $[0, 0, c_3]$ .

16. **Project.** Parts (b) and (d) are basic. They follow from the definitions by direct calculation. Part (a) follows by decomposing each component accordingly.

(c) In the first component in (1) we now have  $fv_3$  instead of  $v_3$ , etc. Product differentiation gives  $(fv_3)_y = f_y v_3 + f \cdot (v_3)_y$ . Similarly for the other five terms in the components.  $f_y v_3$  and the corresponding five terms give  $(\text{grad } f) \times \mathbf{v}$  and the other six terms  $f \cdot (v_3)_y$ , etc. give  $f \text{ curl } \mathbf{v}$ .

(d) For twice continuously differentiable  $f$  the mixed second derivatives are equal, so that the result follows from  $\nabla f = f_x \mathbf{i} + f_y \mathbf{j} + f_z \mathbf{k}$  and (1), which gives

$$\text{curl}(\nabla f) = [(f_z)_y - (f_y)_z] \mathbf{i} + [(f_x)_z - (f_z)_x] \mathbf{j} + [(f_y)_x - (f_x)_y] \mathbf{k}.$$

(e) Write out and compare the twelve terms on either side.

18.  $\text{curl}(f\mathbf{u}) = [x^3z - 3xyz^2, xy^3 - 3x^2yz, yz^3 - 3xy^2z]$   
 $\text{curl}(g\mathbf{u}) = [x^2 - 3z^2 - 2zx - 2yz, y^2 - 3x^2 - 2xy - 2zx,$   
 $z^2 - 3y^2 - 2xy - 2yz]$   
 20.  $\text{curl}(\mathbf{u} \times \mathbf{v}) = [2xyz - z^3 - x^2y, 2xyz - x^3 - y^2z, 2xyz - y^3 - z^2x]$ . Furthermore,  
 $\text{curl}(\mathbf{v} \times \mathbf{u}) = -\text{curl}(\mathbf{u} \times \mathbf{v})$ .

**SOLUTIONS TO CHAP. 9 REVIEW QUESTIONS AND PROBLEMS, page 416**

12. 0 (orthogonal), 19,  $[-56, 7, 22]$
14. 744, 744, 744, 77
16. 389, 389, 389. Of course, the third expression is just the usual notation for the scalar triple product, and the first two expressions justify such a notation that does not indicate where the dot and the cross is being used because it does not matter.
18. Unit vectors  $(1/\sqrt{62})[3, 2, 7]$ ,  $(1/\sqrt{65})[1, 8, 0]$
20.  $0.90 = |\sqrt{62} - \sqrt{77}| < 11.79 = \sqrt{139} < 16.65 = \sqrt{62} + \sqrt{77}$ . This illustrates the triangle inequality (Sec. 9.2) and consequences of it.
22.  $\cos \gamma = [4, 3, -1] \cdot [1, 1, 1]/\sqrt{26 \cdot 3} = 6/\sqrt{26 \cdot 3} = 0.6794$ ,  $\gamma = 47.2^\circ$
24.  $[-19, -13, -3]$ , the negative of the sum of those vectors
26.  $\mathbf{q} \cdot [2, -5, 0] = 5$
28. See Prob. 41 in Problem Set 9.2.
30.  $\mathbf{m} = \mathbf{r} \times \mathbf{p} = [-4, 3, 0] \times [4, 2, 0] = [0, 0, -20]$ . The moment has the tendency to produce a clockwise rotation.
32.  $\mathbf{v} = \mathbf{r}' = [-5 \sin t, \cos t, 2]$ , where  $t = \frac{1}{4}\pi$ , so that

$$\mathbf{v}(P) = \mathbf{r}'(P) = [-5/\sqrt{2}, 1/\sqrt{2}, 2], \quad |\mathbf{v}(P)| = \sqrt{17},$$

and for the acceleration we obtain

$$\mathbf{a} = \mathbf{v}' = [-5 \cos t, -\sin t, 0]$$

$$\mathbf{a}(P) = [-5/\sqrt{2}, -1/\sqrt{2}, 0].$$

The curve is a helix on an elliptic cylinder.

34. Vectors in the plane are

$$[2 - 1, 3 - 0, 5 - 2] = [1, 3, 3]$$

and

$$[3 - 1, 5 - 0, 7 - 2] = [2, 5, 5].$$

Their vector product is  $[0, 1, -1]$ . This is a normal vector of the plane. Hence an equation of the plane is  $y - z = c$ , and by substituting the coordinates of any of the three points we see that  $c = -2$ . *Answer:*  $z = y + 2$

36.  $\text{grad } f = [y, z + x, y]$ . At  $P$  it has the value  $[4, 3, 4]$ . Hence  $f \text{ grad } f$  has at  $P$  the value  $[48, 36, 48]$ .
38. 4, 0
40. 0, 0
42. We obtain

$$\begin{aligned} & \frac{1}{\sqrt{x^4 + y^4 + z^4}} [y^2, z^2, x^2] \cdot [y, z + x, y] \\ &= \frac{1}{\sqrt{x^4 + y^4 + z^4}} (y^3 + z^3 + z^2x + x^2y). \end{aligned}$$

At  $(1, 2, 0)$  this gives the value  $10/\sqrt{17}$ .

44. We obtain

$$\begin{aligned} \text{div}(\mathbf{v} \times \mathbf{w}) &= \text{div}([zx^2 - (4z - x)z^2, (4z - x)y^2 - yx^2, yz^2 - zy^2]) \\ &= 2zx + z^2 + 8yz + 2zy - 2xy - x^2 - y^2. \end{aligned}$$

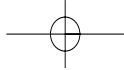

## CHAPTER 10 Vector Integral Calculus. Integral Theorems

### SECTION 10.1. Line Integrals, page 420

**Purpose.** To explain line integrals in space and in the plane conceptually and technically with regard to their evaluation by using the representation of the path of integration.

#### Main Content, Important Concepts

Line integral (3), (3'), its evaluation

Its motivation by work done by a force ("work integral")

General properties (5)

Dependence on path (Theorem 2)

**Background Material.** Parametric representation of curves (Sec. 9.5); a couple of review problems may be useful.

#### Comments on Content

The integral (3) is more practical than (8) (more direct in view of subsequent material), and work done by a force motivates it sufficiently well.

Independence of path is settled in the next section.

### SOLUTIONS TO PROBLEM SET 10.1, page 425

2.  $\mathbf{r}(t) = [t, 10t, 0]$ ,  $0 \leq t \leq 2$ ,  $\mathbf{r}' = [1, 10, 0]$ ,  $\mathbf{F}(\mathbf{r}(t)) = [1000t^3, t^3, 0]$ . Hence the integral is

$$\int_0^2 1010t^3 dt = 4040.$$

The path of integration is shorter than that in Prob. 1, but the value of the integral is greater. This is not unusual.

4.  $\mathbf{r} = [2 \cos t, 2 \sin t, 0]$ ,  $0 \leq t \leq \pi$ ,  $\mathbf{r}' = [-2 \sin t, 2 \cos t]$ . Hence  $\mathbf{F}(\mathbf{r}(t)) = [4 \cos^2 t, 4 \sin^2 t, 0]$ . This gives the integral

$$\int_0^\pi (-8 \cos^2 t \sin t + 8 \sin^2 t \cos t) dt = -\frac{16}{3} + 0.$$

6. Clockwise integration is requested, so that we take, say,  $\mathbf{r} = [\cos t, -\sin t]$ ,  $0 \leq t \leq \frac{1}{2}\pi$ . By differentiation,  $\mathbf{r}' = [-\sin t, -\cos t]$ . Hence

$$\mathbf{F}(\mathbf{r}(t)) = [e^{\cos t}, e^{-\sin t}],$$

and the integral is

$$\int_0^{\pi/2} (-e^{\cos t} \sin t - e^{-\sin t} \cos t) dt = [e^{\cos t} + e^{-\sin t}]_0^{\pi/2}.$$

This gives the *answer*  $-2 \sinh 1$ .

8.  $\mathbf{r} = [t, t^2, t^3]$ ,  $0 \leq t \leq \frac{1}{2}$ ,  $\mathbf{r}' = [1, 2t, 3t^2]$ . Hence

$$\mathbf{F}(\mathbf{r}(t)) = [\cosh t, \sinh t^2, e^{t^3}].$$





This gives the integral

$$\int_0^{1/2} (\cosh t + 2t \sinh t^2 + 3t^2 e^{t^3}) dt = \sinh \frac{1}{2} + \cosh \frac{1}{4} + e^{1/8} - 2 = 0.6857.$$

10. Here we integrate around a triangle in space. For the three sides and corresponding integrals we obtain

$$\mathbf{r}_1 = [t, t, 0], \quad \mathbf{r}'_1 = [1, 1, 0], \quad \mathbf{F}(\mathbf{r}_1(t)) = [t, 0, 2t], \quad \int_0^1 t dt = \frac{1}{2}$$

$$\mathbf{r}_2 = [1, 1, t], \quad \mathbf{r}'_2 = [0, 0, 1], \quad \mathbf{F}(\mathbf{r}_2(t)) = [1, -t, 2], \quad \int_0^1 2 dt = 2$$

$$\mathbf{r}_3 = [1-t, 1-t, 1-t], \quad \mathbf{r}'_3 = [-1, -1, -1],$$

$$\mathbf{F}(\mathbf{r}_3(t)) = [1-t, -1+t, 2-2t], \quad \int_0^1 (-2+2t) dt = -2+1.$$

Hence the answer is 3/2.

12.  $\mathbf{r} = [\cos t, \sin t, t]$ ,  $\mathbf{r}' = [-\sin t, \cos t, 1]$ . From  $\mathbf{F} = [y^2, x^2, \cos^2 z]$  we obtain  $\mathbf{F}(\mathbf{r}(t)) = [\sin^2 t, \cos^2 t, \cos^2 t]$ . Hence the integral is

$$\int_0^{4\pi} (-\sin^3 t + \cos^3 t + \cos^2 t) dt = 0 + 0 + 2\pi = 2\pi.$$

14. **Project. (a)**  $\mathbf{r} = [\cos t, \sin t]$ ,  $\mathbf{r}' = [-\sin t, \cos t]$ . From  $\mathbf{F} = [xy, -y^2]$  we obtain  $\mathbf{F}(\mathbf{r}(t)) = [\cos t \sin t, -\sin^2 t]$ . Hence the integral is

$$-2 \int_0^{\pi/2} \cos t \sin^2 t dt = -\frac{2}{3}.$$

Setting  $t = p^2$ , we have  $\mathbf{r} = [\cos p^2, \sin p^2]$  and

$$\mathbf{F}(\mathbf{r}(p)) = [\cos p^2 \sin p^2, -\sin^2 p^2].$$

Now  $\mathbf{r}' = [-2p \sin p^2, 2p \cos p^2]$ , so that the integral is

$$\int_0^{\sqrt{\pi/2}} (-2p \cos p^2 \sin^2 p^2 - 2p \cos p^2 \sin^2 p^2) dp = -\frac{2}{3}.$$

- (b)  $\mathbf{r} = [t, t^n]$ ,  $\mathbf{F}(\mathbf{r}(t)) = [t^{n+1}, -t^{2n}]$ ,  $\mathbf{r}' = [1, nt^{n-1}]$ . The integral is

$$\int_0^1 (t^{n+1} - nt^{3n-1}) dt = \frac{1}{n+2} - \frac{1}{3}.$$

- (c) The limit is  $-1/3$ . The first portion of the path gives 0, since  $y = 0$ . The second portion is  $\mathbf{r}_2 = [1, t]$ , so that  $\mathbf{F}(\mathbf{r}_2(t)) = [t, -t^2]$ ,  $\mathbf{r}' = [0, 1]$ . Hence the integrand is  $-t^2$ , which upon integration gives  $-1/3$ .

16. By integration,

$$\int_0^2 (1 - \sinh^2 t) dt = 2 - \int_0^2 \frac{1}{2}(\cosh 2t - 1) dt = 3 - \frac{1}{4} \sinh 4.$$

18.  $\mathbf{F}(\mathbf{r}(t)) = [\cos t \sin t, \tan t, 0]$ . Integration from 0 to  $\pi/4$  gives the vector

$$\left[-\frac{1}{2} \cos^2 t, -\ln \cos t, 0\right]_0^{\pi/4} = \left[\frac{1}{4}, \frac{1}{2} \ln 2, 0\right].$$

20.  $\mathbf{r} = [t, \frac{4}{3}t]$ ,  $0 \leq t \leq 3$ ,  $L = 5$ ,  $|\mathbf{F}| = \sqrt{t^4 + \frac{16}{9}t^2}$ . The derivative is

$$\frac{1}{2}[t^4 + \frac{16}{9}t^2]^{-1/2}(4t^3 + \frac{32}{9}t).$$

The expression in parentheses ( $\cdot \cdot \cdot$ ) has the root  $t = 0$ , but no further real roots. Hence the maximum of  $|\mathbf{F}|$  is taken at  $(3, 4)$ , so that we obtain the bound

$$L|\mathbf{F}| \leq 5\sqrt{81 + 16} = 5\sqrt{97} < 50.$$

Calculation gives  $\mathbf{r}' = [1, \frac{4}{3}]$ ,  $\mathbf{F}(\mathbf{r}(t)) = [t^2, \frac{4}{3}t]$ . The integral is

$$\int_0^3 (t^2 + \frac{16}{9}t) dt = 9 + 8 = 17.$$

## SECTION 10.2. Path Independence of Line Integrals, page 426

**Purpose.** Independence of path is a basic issue on line integrals, and we discuss it here in full.

### Main Content, Important Concepts

Definition of independence of path

Relation to gradient (Theorem 1), potential theory

Integration around closed curves

Work, conservative systems

Relation to exactness of differential forms

### Comment on Content

We see that our text pursues three ideas by relating path independence to (i) gradients (potentials), (ii) closed paths, and (iii) exactness of the form under the integral sign. The complete proof of the latter needs Stokes's theorem, so here we leave a small gap to be easily filled in Sec. 10.9.

It would not be a good idea to delay introducing the important concept of path independence until Stokes's theorem is available.

## SOLUTIONS TO PROBLEM SET 10.2, page 432

2. The exactness test for path independence gives  $2ye^{2x} = 2ye^{2x}$ .  $f(x, y) = \frac{1}{2}y^2e^{2x}$  and  $f(0, 5) - f(5, 0) = 12.5 - 0$ .

4. The exactness test for path independence gives  $-2 \cos y \sin y = -2 \cos y \sin y$ .  $f = x \cos^2 y$ ,  $f(6, \pi) - f(2, 0) = 6 \cdot 1 - 2 \cdot 1 = 4$ .

6. For the  $dx$ -term and the  $dy$ -term the exactness test gives

$$2xye^{x^2+y^2-2z} = 2xye^{x^2+y^2-2z}.$$

Etc.  $f = \frac{1}{2}e^{x^2+y^2-2z}$ . Evaluation at the limits gives  $\frac{1}{2}e^2 - \frac{1}{2}$ .

8. For the  $dx$ -term and the  $dy$ -term the exactness test for path independence gives  $-6xy^2 = -6xy^2$ , etc.  $f = x^2(y^3 - z^3)$ . Evaluation at the limits of integration gives  $16 \cdot 64 - 4 \cdot (-1) = 1028$ .

10. **Project.** (a)  $2y^2 \neq x^2$  from  $(6'')$ .

(b)  $\mathbf{r} = [t, bt]$ ,  $0 \leq t \leq 1$ , represents the first part of the path. By integration,  $b/4 + b^3/2$ . On the second part,  $\mathbf{r} = [1, t]$ ,  $b \leq t \leq 1$ . Integration gives  $2(1 - b^3)/3$ .

Equating the derivative of the sum of the two expressions to zero gives  $b = 1/\sqrt{2} = 0.70711$ . The corresponding maximum value of  $I$  is  $1/(6\sqrt{2}) + 2/3 = 0.78452$ .

(c) The first part is  $y = x/c$  or  $\mathbf{r} = [t, t/c], 0 \leq t \leq c$ . The integral over this portion is  $c^3/4 + c/2$ . For the second portion  $\mathbf{r} = [t, 1], c \leq t \leq 1$ , the integral is  $(1 - c^3)/3$ . For  $c = 1$  we get  $I = 0.75$ , the same as in (b) for  $b = 1$ . This is the maximum value of  $I$  for the present paths through  $(c, 1)$  because the derivative of  $I$  with respect to  $c$  is positive for  $0 \leq c \leq 1$ .

12. Path independent. The test gives  $6x^2e^{2y} = 6x^2e^{2y}$ , etc. We find

$$f = x^3e^{2y} + \frac{1}{2}x^2.$$

The integral has the value  $a^3e^{2b} + \frac{1}{2}a^2$ .

14. Path dependent. The test for path independence is

$$2x \cos y = 2x \cos y \quad (\text{for } x, y)$$

$$0 = 0 \quad (\text{for } z, x)$$

$$0 \neq 2y \quad (\text{for } z, y).$$

16. Path dependent. The test is

$$-2e^x \sin 2y = -2e^x \sin 2y \quad (\text{for } x, y)$$

$$0 \neq -z \quad (\text{for } x, z)$$

and we can terminate here.

18. Path independent.  $f = yz \sinh x$ . The value of the integral is  $bc \sinh a$ .

### SECTION 10.3. Calculus Review: Double Integrals. *Optional*, page 433

**Purpose.** We need double integrals (and line integrals) in the next section and review them here for completeness, suggesting that the student go on to the next section.

#### Content

Definition, evaluation, and properties of double integrals

Some standard applications

Change of variables, Jacobians (6), (7)

Polar coordinates (8)

#### Historical Comment

The two ways of evaluating double integrals explained in the text give the same result. For continuous functions this was known at least to Cauchy. Some calculus books call this **Fubini's theorem**, after the Italian mathematician GUIDO FUBINI (1879–1943; 1939–1943 professor at New York University), who in 1907 proved the result for arbitrary Lebesgue-integrable functions (published in *Atti Accad. Naz. Lincei, Rend.*, **16**, 608–614).

### SOLUTIONS TO PROBLEM SET 10.3, page 438

$$2. \int_0^1 [x^2y + xy^2 + \frac{1}{3}y^3] \Big|_{y=x}^{2x} dx = \int_0^1 [2x^3 + 4x^3 + \frac{8}{3}x^3 - (x^3 + x^3 + \frac{1}{3}x^3)] dx = \frac{19}{12}$$

$$\begin{aligned} 4. \int_0^1 \int_y^{\sqrt{y}} (1 - 2xy) \, dx \, dy &= \int_0^1 [x - x^2y] \Big|_y^{\sqrt{y}} \, dy \\ &= \int_0^1 [\sqrt{y} - y^2 - (y - y^3)] \, dy = \frac{1}{12} \end{aligned}$$

$$\begin{aligned} 6. \int_0^3 \int_x^3 \cosh(x + y) \, dy \, dx &= \int_0^3 [\sinh(x + y)] \Big|_x^3 \, dx \\ &= \int_0^3 (\sinh(x + 3) - \sinh 2x) \, dx \\ &= [\cosh(x + 3) - \frac{1}{2} \cosh 2x] \Big|_{x=0}^3 \\ &= \frac{1}{2} \cosh 6 - \cosh 3 + \frac{1}{2} \end{aligned}$$

$$\begin{aligned} 8. \int_0^1 \frac{1}{2} x^2 y^2 \Big|_{1-x}^{1-x^2} \, dx &= \int_0^1 \frac{1}{2} x^2 [(1 - x^2)^2 - (1 - x)^2] \, dx \\ &= \int_0^1 \frac{1}{2} x^2 (x^4 - 3x^2 + 2x) \, dx = \frac{3}{140} \end{aligned}$$

10. Integrating first over  $y$  and then over  $x$  is simpler than integrating in the opposite order, because of the form of the region of integration, which is the same triangle as in Prob. 2. We obtain

$$\begin{aligned} \int_0^1 \int_x^{2x} xy e^{x^2 - y^2} \, dy \, dx &= \int_0^1 [x(-\frac{1}{2})e^{x^2 - y^2}] \Big|_x^{2x} \, dx \\ &= \int_0^1 (-\frac{1}{2}x)(x^{-3x^2} - 1) \, dx = \frac{1}{12}e^{-3} + \frac{1}{6}. \end{aligned}$$

12. For  $z = 0$  we have  $3x + 4y = 12$ , thus  $y = 3 - \frac{3}{4}x$ ; this is the upper limit of the  $y$ -integration. We then integrate over  $x$  from 0 to 4. The main point of the problem is to see how one can determine limits of integration from the given data. The integral of  $z = 6 - \frac{3}{2}x - 2y$  is now as follows.

$$\begin{aligned} \int_0^4 \int_0^{3-3x/4} (6 - \frac{3}{2}x - 2y) \, dy \, dx &= \int_0^4 [6y - \frac{3}{2}xy - y^2] \Big|_0^{3-3x/4} \, dx \\ &= \int_0^4 [(6 - \frac{3}{2}x)(3 - \frac{3}{4}x) - (3 - \frac{3}{4}x)^2] \, dx \\ &= \int_0^4 (9 - \frac{9}{2}x + \frac{9}{16}x^2) \, dx \\ &= 36 - 36 + 12 \\ &= 12. \end{aligned}$$

We confirm this by the scalar triple product of the edge vectors,

$$\frac{1}{6} \begin{vmatrix} 4 & 0 & 0 \\ 0 & 3 & 0 \\ 0 & 0 & 6 \end{vmatrix} = 12.$$

14.  $\bar{x} = 0$  because of symmetry.  $M = \frac{1}{2}\pi a^2$ . For  $\bar{y}$ , using polar coordinates defined by  $x = r \cos \theta$ ,  $y = r \sin \theta$ , we obtain

$$\begin{aligned}\bar{y} &= \frac{1}{M} \int_0^\pi \int_0^a (r \sin \theta) r \, dr \, d\theta = \frac{1}{M} \int_0^\pi \frac{a^3}{3} \sin \theta \, d\theta \\ &= \frac{2}{\pi a^2} \cdot \frac{a^3}{3} \cdot 2 \\ &= \frac{4a}{3\pi} \\ &= 0.4244a.\end{aligned}$$

For  $a = 1$  we get  $4/(3\pi)$ , as in Example 2. It is obvious that the present semidisk and the quarterdisk in the example have the same  $\bar{y}$ .

16.  $\bar{x} = b/2$  for reasons of symmetry. Since the given  $R$  and its left half (the triangle with vertices  $(0, 0)$ ,  $(b/2, 0)$ ,  $(b/2, h)$ ) have the same  $\bar{y}$ , we can consider that half, for which  $M = \frac{1}{4}bh$ . We obtain

$$\begin{aligned}\bar{y} &= \frac{4}{bh} \int_0^{b/2} \int_0^{2hx/b} y \, dy \, dx = \frac{4}{bh} \int_0^{b/2} \frac{1}{2} \left( \frac{2hx}{b} \right)^2 dx \\ &= \frac{4}{bh} \cdot \frac{1}{2} \left( \frac{2h}{b} \right)^2 \cdot \frac{1}{3} \left( \frac{b}{2} \right)^3 = \frac{h}{3}.\end{aligned}$$

This is the same value as in Prob. 15. This equality of the  $\bar{y}$ -values seems obvious.

18. We obtain

$$\begin{aligned}I_x &= \int_0^{b/2} \int_0^{2hx/b} y^2 \, dy \, dx + \int_{b/2}^b \int_0^{2h-2hx/b} y^2 \, dy \, dx \\ &= \int_0^{b/2} \frac{1}{3} \left( \frac{2hx}{b} \right)^3 dx + \int_{b/2}^b \frac{1}{3} \left[ 2h \left( 1 - \frac{x}{b} \right) \right]^3 dx \\ &= \frac{1}{24} bh^3 + \frac{1}{24} bh^3 = \frac{1}{12} bh^3.\end{aligned}$$

Each of those two halves of  $R$  contributes half to the moment  $I_x$  about the  $x$ -axis. Hence we could have simplified our calculation and saved half the work. Of course, this *does not hold* for  $I_y$ . We obtain

$$\begin{aligned}I_y &= \int_0^{b/2} \int_0^{2hx/b} x^2 \, dy \, dx + \int_{b/2}^b \int_0^{2h-2hx/b} x^2 \, dy \, dx \\ &= \int_0^{b/2} x^2 \left( \frac{2hx}{b} \right) dx + \int_{b/2}^b x^2 \left( 2h - \frac{2hx}{b} \right) dx \\ &= \frac{1}{32} b^3 h + \frac{11}{96} b^3 h = \frac{7}{48} b^3 h.\end{aligned}$$

20. We denote the right half of  $R$  by  $R_1 \cup R_2$ , where  $R_1$  is the rectangular part and  $R_2$  the triangular. The moment of inertia  $I_{x1}$  of  $R_1$  with respect to the  $x$ -axis is

$$I_{x1} = \int_0^{b/2} \int_0^h y^2 \, dy \, dx = \int_0^{b/2} \frac{h^3}{3} dx = \frac{1}{6} bh^3.$$

Similarly for the triangle  $R_2$  we obtain

$$\begin{aligned} I_{x2} &= \int_{b/2}^{a/2} \int_0^{h(2x-a)/(b-a)} y^2 dy dx \\ &= \int_{b/2}^{a/2} \frac{1}{3} \frac{h^3(2x-a)^3}{(b-a)^3} dx \\ &= \frac{1}{24} h^3(a-b). \end{aligned}$$

Together,

$$\frac{1}{2} I_x = \frac{h^3}{24} (3b+a) \quad \text{and} \quad I_x = \frac{1}{12} h^3(3b+a).$$

$I_y$  is the same as in Prob. 19; that is,

$$I_y = \frac{h(a^4 - b^4)}{48(a-b)}.$$

This can be derived as follows, where we integrate first over  $x$  and then over  $y$ , which is simpler than integrating in the opposite order, where we would have to add the two contributions, one over the square and the other over the triangle, which would be somewhat cumbersome. Solving the equation for the right boundary

$$y = \frac{h}{a-b} (a-2x)$$

for  $x$ , we have

$$x = \frac{1}{2h} (ah - (a-b)y)$$

and thus

$$\begin{aligned} \frac{1}{2} I_y &= \int_0^h \int_0^{(ah-(a-b)y)/2h} x^2 dx dy \\ &= \int_0^h \frac{1}{24h^3} (ah - (a-b)y)^3 dy \\ &= \frac{h}{96} (a^3 + a^2b + ab^2 + b^3) = \frac{h(a^4 - b^4)}{96(a-b)}. \end{aligned}$$

Now we multiply by 2, because we considered only the right half of the profile.

#### SECTION 10.4. Green's Theorem in the Plane, page 439

**Purpose.** To state, prove, and apply Green's theorem in the plane, relating line and double integrals.

##### Comment on the Role of Green's Theorem in the Plane

This theorem is a special case of each of the two "big" integral theorems in this chapter, Gauss's and Stokes's theorems (Secs. 10.7, 10.9), but we need it as the essential tool in the proof of Stokes's theorem.

The present theorem must not be confused with *Green's first and second theorems* in Sec. 10.8.

**SOLUTIONS TO PROBLEM SET 10.4, page 444**

$$2. \int_0^{\pi/2} \int_0^{\pi/2} (2 \cos y - \sin x) dx dy = 2 \cdot \frac{1}{2} \cdot \pi \cdot 1 - \frac{1}{2} \pi \cdot 1 = \frac{1}{2} \pi$$

$$4. \int_0^2 \int_0^{x/2} (e^x + e^y) dy dx = \int_0^2 \left( \frac{1}{2} x e^x + e^{x/2} - 1 \right) dx = -\frac{7}{2} + 2e + \frac{1}{2} e^2$$

$$6. \int_0^1 \int_{x^2}^x x \sinh y dy dx = \int_0^1 [x \cosh y] \Big|_{x^2}^x dx = \int_0^1 (x \cosh x - x \cosh x^2) dx.$$

Integration over  $x$  now gives  $\frac{1}{2} \sinh 1 - \cosh 1 + 1$ .

8.  $\mathbf{F} = \text{grad}(e^x \cos y)$ , so that the integral around a closed curve is zero. Also the integrand in (1) on the left is identically zero.

$$10. \int_0^3 \int_1^2 \left( y e^x - \frac{x}{y} \right) dy dx = \int_0^3 \left[ \frac{1}{2} y^2 e^x - x \ln y \right]_1^2 dx = \int_0^3 \left( \frac{3}{2} e^x - x \ln 2 \right) dx.$$

Integration over  $x$  gives

$$\left[ \frac{3}{2} e^x - \frac{1}{2} x^2 \ln 2 \right]_0^3 = \frac{3}{2} e^3 - \frac{3}{2} - \frac{9}{2} \ln 2 = 25.51.$$

12. This is a portion of a circular ring (annulus) bounded by the circles of radii 1 and 2 centered at the origin, in the first quadrant bounded by  $y = x$  and the  $y$ -axis. The integrand is  $-1/y^2 - 2x^2y$ . We use polar coordinates, obtaining

$$\begin{aligned} & \int_{\pi/4}^{\pi/2} \int_1^2 \left( -\frac{1}{r^2 \sin^2 \theta} - 2r^3 \cos^2 \theta \sin \theta \right) r dr d\theta \\ &= \int_{\pi/4}^{\pi/2} \left[ -\frac{\ln 2}{\sin^2 \theta} - \frac{2}{5} (32 - 1) \cos^2 \theta \sin \theta \right] d\theta \\ &= (\ln 2) \left( \cot \frac{\pi}{2} - \cot \frac{\pi}{4} \right) + \frac{62}{15} \left( \cos^3 \frac{\pi}{2} - \cos^2 \frac{\pi}{4} \right) \\ &= -\ln 2 - \frac{31}{15\sqrt{2}} \\ &= -2.155. \end{aligned}$$

14.  $\nabla^2 w = 2 + 2 = 4$ . Answer:  $4\pi$ . Confirmation.  $\mathbf{r} = [\cos s, \sin s]$ ,

$$\mathbf{r}' = [-\sin s, \cos s]. \text{ Outer unit normal vector } \mathbf{n} = [\cos s, \sin s],$$

$$\text{grad } w = [2x, 2y] = [2 \cos s, 2 \sin s], \quad (\text{grad } w) \cdot \mathbf{n} = 2 \cos s \cos s + 2 \sin s \sin s.$$

Integration gives  $2\pi \cdot 2 = 4\pi$ .

16.  $\nabla^2 w = 30(x^4 y + x y^4) = 30r^5(\cos^4 \theta \sin \theta + \cos \theta \sin^4 \theta)$ . Integration gives

$$\begin{aligned} \int_0^\pi \int_0^2 \nabla^2 w r dr d\theta &= 30 \frac{r^7}{7} \Big|_0^2 \int_0^\pi (\cos^4 \theta \sin \theta + \cos \theta \sin^4 \theta) d\theta \\ &= 30 \cdot \frac{128}{7} \left[ -\frac{1}{5} \cos^5 \theta + \frac{1}{5} \sin^5 \theta \right]_0^\pi \\ &= 6 \cdot \frac{128}{7} \cdot 2 = \frac{1536}{7} = 219.43. \end{aligned}$$

18. Set  $F_1 = -ww_y$  and  $F_2 = ww_x$  in Green's theorem, where subscripts  $x$  and  $y$  denote partial derivatives. Then  $(F_2)_x - (F_1)_y = w_x^2 + w_y^2$  because  $\nabla^2 w = 0$ , and

$$\begin{aligned} F_1 dx + F_2 dy &= (-ww_y x' + ww_x y') ds \\ &= w(\text{grad } w) \cdot (y' \mathbf{i} - x' \mathbf{j}) ds \\ &= w(\text{grad } w) \cdot \mathbf{n} ds = w \frac{\partial w}{\partial n} ds \end{aligned}$$

where primes denote derivatives with respect to  $s$ .

20. **Project.** We obtain  $\text{div } \mathbf{F}$  in (11) from (1) if we take  $\mathbf{F} = [F_2, -F_1]$ . Taking  $\mathbf{n} = [y', -x']$  as in Example 4, we get from (1) the right side in (11),

$$(\mathbf{F} \cdot \mathbf{n}) ds = \left( F_2 \frac{dy}{ds} + F_1 \frac{dx}{ds} \right) ds = F_2 dy + F_1 dx.$$

Formula (12) follows from the explanation of (1').

Furthermore,  $\text{div } \mathbf{F} = 7 - 3 = 4$  times the area of the disk of radius 2 gives  $16\pi$ .

For the line integral in (11) we need

$$\mathbf{r} = \left[ 2 \cos \frac{s}{2}, 2 \sin \frac{s}{2} \right], \quad \mathbf{r}' = \left[ -\sin \frac{s}{2}, \cos \frac{s}{2} \right], \quad \mathbf{n} = [y', -x']$$

where  $s$  varies from 0 to  $4\pi$ . This gives

$$\oint_C \mathbf{F} \cdot \mathbf{n} ds = \oint_C (7xy' + 3yx') ds = \int_0^{4\pi} \left( 14 \cos^2 \frac{s}{2} - 6 \sin^2 \frac{s}{2} \right) ds = 16\pi.$$

In (12) we have  $\text{curl } \mathbf{F} = \mathbf{0}$  and

$$\mathbf{F} \cdot \mathbf{r}' = -14 \cos \frac{s}{2} \sin \frac{s}{2} - 6 \cos \frac{s}{2} \sin \frac{s}{2} = -10 \sin s$$

which gives zero upon integration from 0 to  $4\pi$ .

## SECTION 10.5. Surfaces for Surface Integrals, page 445

**Purpose.** The section heading indicates that we are dealing with a tool in surface integrals, and we concentrate our discussion accordingly.

### Main Content, Important Concepts

Parametric surface representation (2) (see also Fig. 239)

Tangent plane

Surface normal vector  $\mathbf{N}$ , unit surface normal vector  $\mathbf{n}$

**Short Courses.** Discuss (2) and (4) and a simple example.

### Comments on Text and Problems

The student should realize and understand that the present parametric representations are the two-dimensional analog of parametric curve representations.

Examples 1–3 and Probs. 1–10 concern some standard surfaces of interest in applications. We shall need only a few of these surfaces, but these problems should help students grasp the idea of a parametric representation and see the relation to representations (1). Moreover, it may be good to collect surfaces of practical interest in one place for possible reference.



### SOLUTIONS TO PROBLEM SET 10.5, page 448

2. Circles, straight lines through the origin. A normal vector is

$$\mathbf{N} = \begin{vmatrix} \mathbf{i} & \mathbf{j} & \mathbf{k} \\ \cos v & \sin v & 0 \\ -u \sin v & u \cos v & 0 \end{vmatrix} = [0, 0, u] = u\mathbf{k}.$$

At the origin this normal vector is the zero vector, so that (4) is violated at  $(0, 0)$ . This can also be seen from the fact that all the lines  $v = \text{const}$  pass through the origin, and the curves  $u = \text{const}$  (the circles) shrink to a point at the origin. **This is a consequence of the choice of the representation, not of the geometric shape of the present surface** (in contrast with the cone, where the apex has a similar property, but for *geometric* reasons).

4.  $x^2 + y^2 = z$ , circles, parabolas with the  $z$ -axis as axis; a normal vector is

$$[-2u^2 \cos v, -2u^2 \sin v, u].$$

6.  $\frac{1}{4}x^2 - y^2 = z$ , hyperbolas, parabolas. A normal vector is

$$[-2u^2 \cosh v, 8u^2 \sinh v, 4u].$$

8.  $z = \arctan(y/x)$ , helices (hence the name!), horizontal straight lines. This surface is similar to a spiral staircase, without steps (as in the Guggenheim Museum in New York). A normal vector is

$$[\sin v, -\cos v, u].$$

10.  $x^2/a^2 + y^2/b^2 + z^2/c^2 = 1$ . Both families of parameter curves consist of ellipses. A normal vector is

$$[bc \cos^2 v \cos u, ac \cos^2 v \sin u, ab \sin v \cos v].$$

12.  $z = \frac{5}{3}x + \frac{1}{3}y - 10$ ; hence  $[u, v, \frac{5}{3}u + \frac{1}{3}v - 10]$ , or if we multiply by 3,

$$\mathbf{r}(u, v) = [3u, 3v, 5u + v - 30].$$

A normal vector is

$$\mathbf{N} = \begin{vmatrix} \mathbf{i} & \mathbf{j} & \mathbf{k} \\ 3 & 0 & 5 \\ 0 & 3 & 1 \end{vmatrix} = [-15, -3, 9].$$

More simply,  $[5, 1, -3]$  by applying grad to the given representation. The two vectors are proportional, as expected.

14. In (3) the center is  $(0, 0, 0)$ . Here it is  $(1, -2, 0)$ . Hence we obtain

$$\mathbf{r}(u, v) = [1 + 5 \cos v \cos u, -2 + 5 \cos v \sin u, 5 \sin v].$$

From this and (4) we obtain the normal vector

$$\mathbf{N} = [25 \cos^2 v \cos u, 25 \cos^2 v \sin u, 25 \cos v \sin v].$$

16. A parametric representation is

$$\mathbf{r}(u, v) = [u \cos v, 2u \sin v, 4u^2].$$

A normal vector is

$$\mathbf{N} = [-16u^2 \cos v, -8u^2 \sin v, 2u].$$

Another one is

$$\begin{aligned}\text{grad}(z - 4x^2 - y^2) &= [-8x, -2y, 1] \\ &= [-8u \cos v, -4u \sin v, 1].\end{aligned}$$

Multiplication by  $2u$  gives the previous normal vector.

18. A representation is

$$\mathbf{r}(u, v) = [2 \cosh u, 3 \sinh u, v].$$

A normal vector is

$$\mathbf{N} = [3 \cosh u, -2 \sinh u, 0].$$

Note that  $\mathbf{N}$  is parallel to the  $xy$ -plane. Another normal vector is

$$\text{grad}(9x^2 - 4y^2) = [18x, -8y, 0] = [36 \cosh u, -24 \sinh u, 0].$$

Division by 12 gives the previous normal vector.

20. Set  $x = u$  and  $y = v$ .

22.  $\mathbf{N}(0, 0) = \mathbf{0}$  in Prob. 2 (polar coordinates); see the answer to Prob. 2. In Probs. 4 and 7 (paraboloids) the situation is similar to that of the polar coordinates. In Prob. 6 the origin is a saddle point. In each of these cases one can find a representation for which  $\mathbf{N}(0, 0) \neq \mathbf{0}$ ; see Prob. 23 for the paraboloid. In Prob. 5 the reason is the form of the surface (the apex of the cone, where no tangent plane and hence no normal exists).

24. **Project.** (a)  $\mathbf{r}_u(P)$  and  $\mathbf{r}_v(P)$  span  $T(P)$ .  $\mathbf{r}^*$  varies over  $T(P)$ . The vanishing of the scalar triple product implies that  $\mathbf{r}^* - \mathbf{r}(P)$  lies in the tangent plane  $T(P)$ .

(b) Geometrically, the vanishing of the dot product means that  $\mathbf{r}^* - \mathbf{r}(P)$  must be perpendicular to  $\nabla g$ , which is a normal vector of  $S$  at  $P$ .

(c) Geometrically,  $f_x(P)$  and  $f_y(P)$  span  $T(P)$ , so that for any choice of  $x^*, y^*$  the point  $(x^*, y^*, z^*)$  lies in  $T(P)$ . Also,  $x^* = x, y^* = y$  gives  $z^* = z$ , so that  $T(P)$  passes through  $P$ , as it should.

## SECTION 10.6. Surface Integrals, page 449

**Purpose.** We define and discuss surface integrals with and without taking into account surface orientations.

### Main Content

Surface integrals (3)  $\equiv$  (4)  $\equiv$  (5)

Change of orientation (Theorem 1)

Integrals (6) without regard to orientation; also (11)

### Comments on Content

The right side of (3) shows that we need only  $\mathbf{N}$  but not the corresponding unit vector  $\mathbf{n}$ .

An orientation results automatically from the choice of a surface representation, which determines  $\mathbf{r}_u$  and  $\mathbf{r}_v$  and thus  $\mathbf{N}$ .

The existence of nonorientable surfaces is interesting but is not needed in our further work.

## SOLUTIONS TO PROBLEM SET 10.6, page 456

2.  $\mathbf{r} = [u, v, 4 - u - v]$ ,  $0 \leq u \leq 4 - v$ ,  $0 \leq v \leq 4$ ,

$\mathbf{F} = [u^2, v^2, (4 - u - v)^2]$ ,  $\mathbf{N} = [1, 1, 1]$ . From this we obtain

$$\int_0^4 \int_0^{4-v} \mathbf{F} \cdot \mathbf{N} \, du \, dv = \int_0^4 \left[ \frac{1}{3}u^3 + v^2u - \frac{1}{3}(4 - u - v)^3 \right] \Big|_0^{4-v} \, dv = 64.$$

4. Quarter of a circular cylinder of radius 3 and height 2 in the first octant with the  $z$ -axis as axis. A parametric representation is

$$\mathbf{r} = [3 \cos u, 3 \sin u, v], \quad 0 \leq u \leq \frac{1}{2}\pi, \quad 0 \leq v \leq 2.$$

From this we obtain

$$\mathbf{N} = [3 \cos u, 3 \sin u, 0]$$

$$\mathbf{F} \cdot \mathbf{N} = 3e^{3 \sin u} \cos u - 3e^v \sin u.$$

Integration over  $u$  from 0 to  $\frac{1}{2}\pi$  gives  $e^3 - 1 - 3e^v$ . Integration of this over  $v$  from 0 to 2 gives the *answer*

$$2(e^3 - 1) - 3(e^2 - 1) = 2e^3 - 3e^2 + 1 = 19.0039.$$

6.  $\mathbf{r} = [u, \cos v, \sin v]$ ,  $0 \leq u \leq 20$ ,  $0 \leq v \leq \pi$ ,  $\mathbf{N} = [0, -\cos v, -\sin v]$ ; hence

$$\mathbf{F} \cdot \mathbf{N} = -\cos^4 v \sin v.$$

Integration over  $v$  from 0 to  $\pi$  gives  $-2/5$ . Integration of this over  $u$  from 0 to 20 gives the *answer*  $-8$ .

8.  $\mathbf{r} = [u, \cos v, 3 \sin v]$ ,  $\mathbf{N} = [0, -3 \cos v, -\sin v]$ ; hence

$$\mathbf{F} = [\tan(u \cos v), u^2 \cos v, -3 \sin v].$$

This gives

$$\mathbf{F} \cdot \mathbf{n} = -3u^2 \cos^2 v + 3 \sin^2 v.$$

Integration over  $u$  from 1 to 4 gives

$$-63 \cos^2 v + 9 \sin^2 v.$$

Integration of this over  $v$  from 0 to  $2\pi$  gives the *answer*

$$-63\pi + 9\pi = -54\pi.$$

10. Portion of a circular cone with the  $z$ -axis as axis. A parametric representation is

$$\mathbf{r} = [u \cos v, u \sin v, 4u] \quad (0 \leq u \leq 2, 0 \leq v \leq \pi).$$

From this,

$$\mathbf{N} = [-4u \cos v, -4u \sin v, u], \quad \mathbf{F} = [u^2 \sin^2 v, u^2 \cos^2 v, 256u^4].$$

The integrand is

$$\mathbf{F} \cdot \mathbf{n} = -4u^3 \sin^2 v \cos v - 4u^3 \cos^2 v \sin v + 256u^5.$$

Integration over  $u$  from 0 to 2 gives

$$-16 \sin^2 v \cos v - 16 \cos^2 v \sin v + \frac{8192}{3}.$$

Integration of this over  $v$  from 0 to  $\pi$  gives

$$\left[ -\frac{16}{3} \sin^3 v + \frac{16}{3} \cos^3 v + \frac{8192}{3} v \right]_0^\pi = -\frac{32}{3} + \frac{8192}{3} \pi = 8568.$$

12.  $\mathbf{r} = [u, v, u + v^2]$ ,  $\mathbf{N} = [-1, -2v, 1]$ ,  $\mathbf{F} = [\cosh v, 0, \sinh u]$ . Hence the integrand is

$$\mathbf{F} \cdot \mathbf{N} = -\cosh v + \sinh u.$$

Integration over  $v$  from 0 to  $u$  gives  $-\sinh u + u \sinh u$ . Integration of this over  $u$  from 0 to 1 gives

$$[-\cosh u + u \cosh u - \sinh u] \Big|_0^1 = 1 - \sinh 1.$$

14.  $\mathbf{r} = [u, v, 2 - u - v]$ ,  $0 \leq u \leq 2$ ,  $0 \leq v \leq 2 - u$ ,  $\mathbf{N} = [1, 1, 1]$ ,  $|\mathbf{N}| = \sqrt{3}$ ,  $G = \cos v + \sin u$ ; hence

$$\int_0^{2-u} G|\mathbf{N}| dv = \sqrt{3}[\sin v + v \sin u] \Big|_0^{2-u} = \sqrt{3}[\sin(2-u) + (2-u) \sin u].$$

Integration over  $u$  from 0 to 2 gives

$$\begin{aligned} & \sqrt{3}[\cos(2-u) - 2 \cos u - \sin u + u \cos u] \Big|_0^2 \\ &= \sqrt{3}[3 - \cos 2 - \sin 2] = 4.342. \end{aligned}$$

16.  $\mathbf{r} = [4 \cos u, 4 \sin u, v]$ ,  $\mathbf{N} = [4 \cos u, 4 \sin u, 0]$ ,  $|\mathbf{N}| = 4$ . Furthermore,

$$G = 4 \sin u e^{4 \cos u} + 4 \cos u e^{4 \sin u} + e^v.$$

Also,  $G|\mathbf{N}|$  is the same times 4. Integration over  $u$  from 0 to  $\pi$  gives

$$\begin{aligned} & 4[-e^{4 \cos u} + e^{4 \sin u} + ue^v] \Big|_0^\pi \\ &= 4(-e^{-4} + e^4 + e^0 - e^0 + \pi e^v). \end{aligned}$$

Integration of this over  $v$  from 0 to 4 gives

$$16(-e^{-4} + e^4) + 4\pi(e^4 - 1) = 1547.$$

18.  $\mathbf{r} = [\cos v \cos u, \cos v \sin u, \sin v]$ ,  $0 \leq u \leq \pi$ ,  $0 \leq v \leq \pi/2$ . A normal vector is

$$\mathbf{N} = [\cos^2 v \cos u, \cos^2 v \sin u, \cos v \sin v] \quad \text{and} \quad |\mathbf{N}| = \cos v.$$

On  $S$ ,

$$G = a \cos v \cos u + b \cos v \sin u + c \sin v.$$

The integrand is this expression times  $\cos v$ . Integration over  $u$  from 0 to  $\pi$  gives

$$0 + 2b \cos^2 v + \pi c \sin v \cos v.$$

Integration of this over  $v$  from 0 to  $\pi/2$  gives the answer

$$\frac{1}{2}\pi(b + c).$$

20.  $\mathbf{r} = [u, v, uv]$ ,  $0 \leq u \leq 1$ ,  $0 \leq v \leq 1$ ,  $\mathbf{N} = [-v, -u, 1]$ , so that

$$|\mathbf{N}| = \sqrt{u^2 + v^2 + 1}.$$

On  $S$  we have

$$G = 3uv, \quad G|\mathbf{N}| = 3uv\sqrt{u^2 + v^2 + 1}.$$

Integration over  $u$  from 0 to 1 gives

$$[v(v^2 + u^2 + 1)^{3/2}] \Big|_0^1 = v(v^2 + 2)^{3/2} - v(v^2 + 1)^{3/2}.$$

Integration of this over  $v$  from 0 to 1 gives

$$\frac{1}{5}[(v^2 + 2)^{5/2} - (v^2 + 1)^{5/2}] \Big|_0^1 = \frac{1}{5}(3^{5/2} - 2^{5/2} - (2^{5/2} - 1)) = 1.055.$$

$$24. I_{x=y} = \iint_S \left[ \frac{1}{2} (x-y)^2 + z^2 \right] \sigma dA$$

$$26. h\pi(1 + h^2/6)$$

28. Proof for a lamina  $S$  of density  $\sigma$ . Choose coordinates so that  $A$  is the  $z$ -axis and  $B$  is the line  $x = k$  in the  $xz$ -plane. Then

$$\begin{aligned} I_B &= \iint_S [(x-k)^2 + y^2] \sigma dA = \iint_S (x^2 - 2kx + k^2 + y^2) \sigma dA \\ &= \iint_S (x^2 + y^2) \sigma dA - 2k \iint_S x \sigma dA + k^2 \iint_S \sigma dA \\ &= I_A - 2k \cdot 0 + k^2 M, \end{aligned}$$

the second integral being zero because it is the first moment of the mass about an axis through the center of gravity.

For a mass distributed in a region in space the idea of proof is the same.

30. **Team Project.** (a) Use  $d\mathbf{r} = \mathbf{r}_u du + \mathbf{r}_v dv$ . This gives (13) and (14) because

$$d\mathbf{r} \cdot d\mathbf{r} = \mathbf{r}_u \cdot \mathbf{r}_u du^2 + 2\mathbf{r}_u \cdot \mathbf{r}_v du dv + \mathbf{r}_v \cdot \mathbf{r}_v dv^2.$$

- (b)  $E, F, G$  appear if you express everything in terms of dot products. In the numerator,

$$\mathbf{a} \cdot \mathbf{b} = (\mathbf{r}_u g' + \mathbf{r}_v h') \cdot (\mathbf{r}_u p' + \mathbf{r}_v q') = Eg'p' + F(g'q' + h'p') + Gh'q'$$

and similarly in the denominator.

- (c) This follows by Lagrange's identity (Problem Set 9.3),

$$\begin{aligned} |\mathbf{r}_u \times \mathbf{r}_v|^2 &= (\mathbf{r}_u \times \mathbf{r}_v) \cdot (\mathbf{r}_u \times \mathbf{r}_v) = (\mathbf{r}_u \cdot \mathbf{r}_u)(\mathbf{r}_v \cdot \mathbf{r}_v) - (\mathbf{r}_u \cdot \mathbf{r}_v)^2 \\ &= EG - F^2. \end{aligned}$$

- (d)  $\mathbf{r} = [u \cos v, u \sin v]$ ,  $\mathbf{r}_u = [\cos v, \sin v]$ ,  $\mathbf{r}_u \cdot \mathbf{r}_u = \cos^2 v + \sin^2 v = 1$ , etc.

- (e) By straightforward calculation,  $E = (a + b \cos v)^2$ , and  $F = 0$  (the coordinate curves on the torus are orthogonal!), and  $G = b^2$ . Hence, as expected,

$$\sqrt{EG - F^2} = b(a + b \cos v).$$

## SECTION 10.7. Triple Integrals. Divergence Theorem of Gauss, page 458

### Purpose, Content

Proof and application of the first "big" integral theorem in this chapter, Gauss's theorem, preceded by a short discussion of triple integrals (probably known to most students from calculus).

### Comment on Proof

The proof is simple:

- Cut (2) into three components. Take the third, (5).

- On the left, integrate  $\iiint \frac{\partial F^3}{\partial z} dz dx dy$  over  $z$  to get

$$(8) \quad \iint [F_3(\text{upper surface}) - F_3(\text{lower surface})] dx dy$$

integrated over the projection  $R$  of the region in the  $xy$ -plane (Fig. 250).

3. Show that the right side of (5) equals (8). Since the third component of  $\mathbf{n}$  is  $\cos \gamma$ , the right side is

$$\begin{aligned}\iint F_3 \cos \gamma \, dA &= \iint F_3 \, dx \, dy \\ &= \iint F_3(\text{upper}) \, dx \, dy - \iint F_3(\text{lower}) \, dx \, dy,\end{aligned}$$

where minus comes from  $\cos \gamma < 0$  in Fig. 250, lower surface. This is the proof. Everything else is (necessary) accessory.

### SOLUTIONS TO PROBLEM SET 10.7, page 463

2. Integration over  $x$  from 0 to 4 gives  $\frac{64}{3} + 4y^2 + 4z^2$ . Integration of this over  $y$  from 0 to 9 gives  $1164 + 36z^2$ . Integration of this over  $z$  from 0 to 1 gives 1176. Alternatively, integration of  $x^2$ ,  $y^2$ ,  $z^2$  over  $T$  gives

$$\frac{4^3}{3} \cdot 9 \cdot 1 = 192, \quad \frac{9^3}{3} \cdot 4 \cdot 1 = 972, \quad \frac{1^3}{3} \cdot 4 \cdot 9 = 12$$

respectively. The sum is 1176.

4. Limits of integration  $0 \leq x \leq 2 - y - z$ ,  $0 \leq y \leq 2 - z$ ,  $0 \leq z \leq 2$ . Integration over  $x$  gives  $-e^{-2} + e^{-y-z}$ . Integration of this over  $y$  gives  $-3e^{-2} + ze^{-2} + e^{-z}$ . Integration of this over  $z$  gives the *answer*  $-5e^{-2} + 1$ .
6. Integration over  $y$  from 0 to  $1 - x^2$  gives  $30z(1 - x^2)$ . Integration of this over  $z$  from 0 to  $x$  gives  $15(x^2 - x^4)$ . Integration of this over  $x$  from 0 to 1 gives the *answer* 2.
8. From (3) in Sec. 10.5 with variable  $r$  instead of constant  $a$  we have

$$x = r \cos v \cos u, \quad y = r \cos v \sin u, \quad z = r \sin v.$$

Hence  $x^2 + y^2 = r^2 \cos^2 v$ . The volume element is  $dV = r^2 \cos v \, dr \, du \, dv$ . The limits of integration are  $0 \leq r \leq a$ ,  $0 \leq u \leq 2\pi$ ,  $-\frac{1}{2}\pi \leq v \leq \frac{1}{2}\pi$ . The integrand is  $r^4 \cos^3 v$ . Integration over  $r$ ,  $u$ , and  $v$  gives  $a^5/5$ ,  $2\pi$ , and  $4/3$ , respectively. The product of these is the *answer*  $8\pi a^5/15$ .

10. Integration over  $x$ ,  $y$ , and  $z$  gives successively

$$a(y^2 + z^2), \quad \frac{1}{12}ab^3 + z^2ab, \quad \frac{1}{12}abc(b^2 + c^2).$$

12.  $8\pi a^5/15$ , as follows from Prob. 8.
14.  $r^2 = y^2 + z^2$ . Integration over  $r$  from 0 to  $\sqrt{x}$  gives  $x^2/4$ . Integration of this over  $x$  from 0 to  $h$  gives  $h^3/12$ . *Answer*:  $h^3\pi/6$ .
16.  $\pi h^5/10 = \pi h^3/6$  gives  $h = \sqrt{5/3}$ . For  $h > \sqrt{5/3}$  the moment  $I_x$  is larger for the cone because the mass of the cone is spread out farther than that of the paraboloid when  $x > 1$ .
18.  $\operatorname{div} \mathbf{F} = 4$ . *Answer*: 4 times the volume  $\pi r^2 h/3$  of a cone of base radius  $r = 2$  and height  $h = 2$ . *Answer*:  $4\pi \cdot 4 \cdot 2/3 = 32\pi/3$ .
20.  $\operatorname{div} \mathbf{F} = 4x^2$ . Set  $x = r \cos u$ ,  $y = r \sin u$ . The integrand times the volume element is

$$(4r^2 \cos^2 u)r \, dr \, du \, dz.$$

Integration over  $r$  from 0 to 5 gives  $5^4 \cos^2 u$ , integration over  $u$  from 0 to  $2\pi$  then gives  $625\pi$ , and integration over  $z$  finally gives  $1250\pi$ .

22.  $\operatorname{div} \mathbf{F} = 3x^2 + 3y^2 + 3z^2 = 3r^2$ ,  $dV = r^2 \cos v \, dr \, du \, dv$ . Intervals of integration  $0 \leq r \leq 5$ ,  $0 \leq u \leq 2\pi$ ,  $0 \leq v \leq \frac{1}{2}\pi$ . The integrand is  $3r^4 \cos v$ . Integration over  $r$ ,  $v$ , and  $u$  gives successively

$$1875 \cos v, \quad 1875, \quad 3750\pi.$$

24.  $\operatorname{div} \mathbf{F} = 8x + 2y + 2\pi \sin \pi z$ . Integration over  $z$  from 0 to  $1 - x - y$  gives

$$2 + (1 - x - y)(8x + 2y) - 2 \cos [\pi(1 - x - y)].$$

Integration of this over  $y$  from 0 to  $1 - x$  gives

$$\frac{7}{3} + x - 7x^2 + \frac{11}{3}x^3 - \frac{2}{\pi} \sin [\pi(1 - x)].$$

Integration of this over  $x$  from 0 to 1 now gives the *answer*  $17/12 - 4/\pi^2$ .

### SECTION 10.8. Further Applications of the Divergence Theorem, page 463

**Purpose.** To represent the divergence free of coordinates and to show that it measures the source intensity (Example 1); to use Gauss's theorem for deriving the **heat equation** governing heat flow in a region (Example 2); to obtain basic properties of harmonic functions.

#### Main Content, Important Concepts

Total flow (1) out of a region

Divergence as the limit of a surface integral; see (2)

Heat equation (5) (to be discussed further in Chap. 12)

Properties of harmonic functions (Theorems 1–3)

Green's formulas (8), (9)

**Short Courses.** This section can be omitted.

#### Comments on (2)

Equation (2) is sometimes used as a *definition* of the divergence, giving independence of the choice of coordinates immediately. Also, Gauss's theorem follows more readily from this definition, but since its proof is simple (see Sec. 10.7. in this Manual), that savings is marginal. Also, it seems that to the student our Example 2 in Sec. 9.8 motivates the divergence at least as well (and without integrals) as (2) in the present section does for a beginner.

### SOLUTIONS TO PROBLEM SET 10.8, page 468

2.  $\mathbf{r} = [\cos \theta, \sin \theta] = \mathbf{N} = \mathbf{n}$ ,  $f = \sin^2 \theta - \cos^2 \theta = -2 \cos 2\theta$  gives the integral 0. The integrals over the disks ( $z = 0$  and  $z = 5$ ) are 0, too, because  $\nabla f$  has no component in the  $z$ -direction (the normal direction of those disks).
4.  $\nabla^2 g = 4$ ,  $\operatorname{grad} f \cdot \operatorname{grad} g = [1, 0, 0] \cdot [0, 2y, 2z] = 0$ . Integration of  $4x$  over the box gives 12. Also,  $f \partial g / \partial n$  for the six surfaces gives

$$(x = 0) \quad 0[-1, 0, 0] \cdot [0, 2y, 2z], \quad \text{integral } 0$$

$$(x = 1) \quad 1[1, 0, 0] \cdot [0, 2y, 2z], \quad \text{integral } 0$$

$$(y = 0) \quad x[0, -1, 0] \cdot [0, 0, 2z], \quad \text{integral } 0$$

$$\begin{array}{lll} (y = 2) & x[0, 1, 0] \cdot [0, 4, 2z], & \text{integral of } 4x \text{ gives } 2 \cdot 3 = 6 \\ (z = 0) & x[0, 0, -1] \cdot [0, 2y, 0] & \text{integral } 0 \\ (z = 3) & x[0, 0, 1] \cdot [0, 2y, 6] & \text{integral of } 6x \text{ gives } 3 \cdot 2 = 6. \end{array}$$

6. The volume integral of  $2x^4 - 12x^2y^2$  is  $2/5 - 4/3$ . The surface integral of

$$x^4 \mathbf{n} \cdot [0, 2y, 0] - y^2 \mathbf{n} \cdot [4x^3, 0, 0] = \mathbf{n} \cdot [-4y^2x^3, 2yx^4, 0]$$

is  $-4/3$  ( $x = 1$ ) and  $2/5$  ( $y = 1$ ) and 0 for the other faces.

8.  $r = a$ ,  $\cos \phi = 1$ ,  $V = \frac{1}{3}a(4\pi a^2)$

10. **Team Project.** (a) Put  $f = g$  in (8).

(b) Use (a).

(c) Use (9).

(d)  $h = f - g$  is harmonic and  $\partial h / \partial n = 0$  on  $S$ . Thus  $h = \text{const}$  in  $T$  by (b).

(e) Use  $\text{div}(\text{grad } f) = \nabla^2 f$  and (2).

### SECTION 10.9. Stokes's Theorem, page 468

**Purpose.** To prove, explain, and apply Stokes's theorem, relating line integrals over closed curves and surface integrals.

#### Main Content

Formula (2)  $\equiv$  (2\*)

Further interpretation of the curl (see also Sec. 9.9)

Path independence of line integrals (leftover from Sec. 10.2)

#### Comment on Orientation

Since the choice of right-handed or left-handed coordinates is essential to the curl (Sec. 9.9), surface orientation becomes essential here (Fig. 251).

#### Comment on Proof

The proof is simple:

1. Cut (2\*) into components. Take the first, (3).
2. Using  $N_1$  and  $N_3$ , cast the left side of (3) into the form (7).
3. Transform the right side of (3) by Green's theorem in the plane into a double integral and show equality with the integral obtained on the left.

### SOLUTIONS TO PROBLEM SET 10.9, page 473

2.  $\mathbf{r} = [2 \cos u, 2 \sin u, v]$ ,  $\text{curl } \mathbf{F} = [0, -5 \cos v, 0] = [0, -5 \cos v, 0]$ . Also

$$\mathbf{N} = [2 \cos u, 2 \sin u, 0].$$

Hence

$$(\text{curl } \mathbf{F}) \cdot \mathbf{N} = -5(\cos v) 2 \sin u.$$

Integration over  $u$  from 0 to  $\pi$  gives  $-20 \cos v$ . Integration of this over  $v$  from 0 to  $\frac{1}{2}\pi$  gives  $-20$ . Answer:  $\pm 20$ .

4.  $\text{curl } \mathbf{F} = [-\sinh z, -1, 3 \sin y]$ ,  $\mathbf{N} = [0, 0, 1]$ . Hence

$$(\text{curl } \mathbf{F}) \cdot \mathbf{N} = 3 \sin y.$$



Integration over  $y$  from 0 to 2 and then over  $x$  from 0 to 2 gives

$$-3(\cos 2 - 1) \cdot 2 = -6(\cos 2 - 1).$$

The *answer* is  $\pm 6(\cos 2 - 1) = \mp 8.497$ .

6.  $\mathbf{r} = [u \cos v, u \sin v, u]$ ,  $\text{curl } \mathbf{F} = [2y, 2z, 2x] = [2u \sin v, 2u, 2u \cos v]$ .  
Furthermore,

$$\mathbf{n} \, dA = \mathbf{N} \, du \, dv = [-u \cos v, -u \sin v, u] \, du \, dv.$$

Hence the integrand is

$$-2u^2 \cos v \sin v - 2u^2 \sin v + 2u^2 \cos v.$$

Integration over  $u$  from 0 to 2 gives

$$\frac{16}{3}(-\cos v \sin v - \sin v + \cos v).$$

Integration of this from 0 to  $\pi$  gives  $\frac{16}{3}(-2) = -32/3$ . The *answer* is  $\pm 32/3$ .

8.  $(\text{curl } \mathbf{F}) \cdot \mathbf{N} = [0, 0, -3x^2 - 3y^2] \cdot [0, 0, 1] = -3x^2 - 3y^2 = -3r^2$ . The integral is

$$-3 \int_S \int (x^2 + y^2) \, dx \, dy = -3 \int_S \int r^3 \, dr \, d\theta = -\frac{3}{4} r^4 \cdot 2\pi \Big|_0^1 = -\frac{3}{2}\pi.$$

The *answer* is  $\pm 3\pi/2$ .

10.  $\mathbf{r} = [\cos \theta, \sin \theta]$ ,  $\mathbf{F} \cdot \mathbf{r}' = [\sin^3 \theta, -\cos^3 \theta] \cdot [-\sin \theta, \cos \theta]$ . Integration over  $\theta$  from 0 to  $2\pi$  gives  $-3\pi/2$ .
12.  $\mathbf{r} = [u, v, v + 1]$ ,  $\mathbf{N} = [0, -1, 1]$ ,  $\text{curl } \mathbf{F} = [0, 2, -2]$ . Hence  $(\text{curl } \mathbf{F}) \cdot \mathbf{N} = 0 - 2 - 2 = -4$ . The area of the projection  $x^2 + y^2 \leq 1$  is  $\pi$ . This gives the *answer*  $-4\pi$ .
14.  $\mathbf{F} = [y, xy^3, -zy^3]$ ,  $\text{curl } \mathbf{F} = [-3zy^2, 0, y^3 - 1]$ ,  $\mathbf{r} = [u \cos v, u \sin v, b]$ ,  $\mathbf{N} = [0, 0, u]$ ; hence

$$(\text{curl } \mathbf{F}) \cdot \mathbf{N} = (u^3 \sin^3 v - 1)u.$$

Integration over  $u$  from 0 to  $a$  gives

$$\frac{1}{5}a^5 \sin^3 v - \frac{1}{2}a^2.$$

Integration of this over  $v$  from 0 to  $2\pi$  gives the *answer*

$$0 - \pi a^2.$$

To check this directly, we can take

$$\mathbf{r} = \left[ a \cos \frac{s}{a}, a \sin \frac{s}{a}, b \right]$$

$$\mathbf{r}' = \left[ -\sin \frac{s}{a}, \cos \frac{s}{a}, 0 \right]$$

$$\mathbf{F} = \left[ a \sin \frac{s}{a}, a^4 \cos \frac{s}{a} \sin^3 \frac{s}{a}, -a^3 \sin^3 \frac{s}{a} \right]$$

$$\mathbf{F} \cdot \mathbf{r}' = -a \sin^2 \frac{s}{a} + a^4 \cos^2 \frac{s}{a} \sin^3 \frac{s}{a}.$$

Integration of this over  $s$  from 0 to  $2\pi a$  gives  $-\pi a^2$ , as before.

16.  $\text{curl } \mathbf{F} = \mathbf{0}$  gives the *answer* 0.  
 18.  $\text{curl } \mathbf{F} = [1, 1, 1]$ ,  $\mathbf{N} = [0, 0, 1]$  ( $\text{curl } \mathbf{F}) \cdot \mathbf{N} = 1$ . The area of the projection of the given triangle into the  $xy$ -plane is  $1/2$ . This gives the *answer*  $1/2$ .

### SOLUTIONS TO CHAP. 10 REVIEW QUESTIONS AND PROBLEMS, page 473

12. Exact,  $\mathbf{F} = \text{grad } f(x, y, z)$ ,  $f(x, y, z) = x \cos z - y \sin z$ . Hence the integral has the value

$$f(4, 3, 0) - f(-2, 0, \frac{1}{2}\pi) = 4 - 0 = 4.$$

14. Not exact.  $\mathbf{r} = [3 \cos t, 3 \sin t, 1]$ . Hence

$$\begin{aligned} \mathbf{F}(\mathbf{r}) \cdot \mathbf{r}' &= [3 \sin t, 6 \cos t, 9 \cos t \sin t] \cdot [-3 \sin t, 3 \cos t, 0] \\ &= -9 \sin^2 t + 18 \cos^2 t. \end{aligned}$$

Integration over  $t$  from 0 to  $2\pi$  gives  $-9\pi + 18\pi = 9\pi$ .

16. By Stokes's theorem.  $\mathbf{r} = [u, v, 2u]$ ,  $\mathbf{N} = [-2, 0, 1]$ . Furthermore,

$$\begin{aligned} \text{curl } \mathbf{F} &= [0, -\pi \cos \pi x, -\pi(\sin \pi x + \cos \pi y)] \\ &= [0, -\pi \cos \pi u, -\pi(\sin \pi u + \cos \pi v)]. \end{aligned}$$

The inner product is

$$(\text{curl } \mathbf{F}(\mathbf{r})) \cdot \mathbf{N} = -\pi(\sin \pi u + \cos \pi v).$$

Integration over  $u$  from 0 to  $1/2$  gives  $-\frac{1}{2}\pi \cos \pi v - 1$ . Integration of this over  $v$  from 0 to 2 gives  $-2$ . *Answer:*  $-2$ .

18. By Stokes's theorem.  $\text{curl } \mathbf{F} = \mathbf{0}$ . Hence the *answer* is 0.

20. Not exact. We obtain

$$\mathbf{r}' = [-2 \sin t, 2 \cos t, 6]$$

and

$$\mathbf{F}(\mathbf{r}) = [4 \cos^2 t, 4 \sin^2 t, 8 \sin^2 t \cos t].$$

The inner product is

$$\mathbf{F} \cdot \mathbf{r}' = -8 \cos^2 t \sin t + 56 \sin^2 t \cos t.$$

Integration gives

$$\frac{8}{3} \cos^3 t + \frac{56}{3} \sin^3 t \Big|_0^{\pi/2} = 16.$$

22.  $\bar{x} = 0$  by symmetry. The total mass is

$$M = \int_{-1}^1 (1 - x^2) dx = \frac{4}{3}.$$

Hence

$$\bar{y} = \frac{1}{M} \int_{-1}^1 \int_0^{1-x^2} y dy dx = \int_{-1}^1 \frac{3}{8} (1 - x^2)^2 dx = \frac{2}{5}.$$

24.  $x^2 + y^2 = r^2$ . The total mass is

$$M = \int_0^{\pi/2} \int_0^1 r^2 \cdot r dr d\theta = \frac{\pi}{8}.$$

This gives

$$\bar{x} = \frac{1}{M} \int_0^{\pi/2} \int_0^1 (r \cos \theta) r^2 \cdot r \, dr \, d\theta = \frac{8}{5\pi}$$

and  $\bar{y} = \bar{x}$  by symmetry.

26.  $\mathbf{N} = [1, 1, 1]$ ,  $\mathbf{F} \cdot \mathbf{N} = 2x^2 + 4y$ . Integration over  $y$  from 0 to  $1 - x$  gives

$$2x^2(1 - x) + 2(1 - x)^2.$$

Integration of this over  $x$  from 0 to 1 gives  $5/6$ .

28. By Gauss's theorem.  $\operatorname{div} \mathbf{F} = 3$ . The volume of the sphere is  $\frac{4}{3} \cdot 5^3 \pi$ . This gives the answer  $500\pi$ .
30. By direct integration. We can represent the paraboloid in the form

$$\mathbf{r} = [u \cos v, u \sin v, u^2].$$

A normal vector is

$$\mathbf{N} = \mathbf{r}_u \times \mathbf{r}_v = [-2u^2 \cos v, -2u^2 \sin v, u].$$

On the paraboloid,

$$\mathbf{F} = [u^3 \sin^3 v, u^3 \cos^3 v, 3u^4].$$

The inner product is

$$\begin{aligned} \mathbf{F} \cdot \mathbf{N} &= -2u^5 \cos v \sin^3 v - 2u^5 \cos^3 v \sin v + 3u^5 \\ &= -2u^5 \cos v \sin v (\sin^2 v + \cos^2 v) + 3u^5. \end{aligned}$$

Integration of this over  $v$  from 0 to  $2\pi$  gives  $0 + 6\pi u^5$ . Integration of this over  $u$  from 0 to 2 (note that  $z = u^2$  varies from 0 to 4) gives  $6\pi 2^6/6 = 64\pi$ .

32. Direct integration. We have

$$\mathbf{r} = [2 \cos u \cos v, 2 \cos u \sin v, \sin u] \quad (0 \leq u \leq \frac{1}{2}\pi, 0 \leq v \leq 2\pi).$$

From this,

$$\begin{aligned} \mathbf{r}_u &= [-2 \sin u \cos v, -2 \sin u \sin v, \cos u] \\ \mathbf{r}_v &= [-2 \cos u \sin v, 2 \cos u \cos v, 0] \\ \mathbf{N} &= [-2 \cos^2 u \cos v, -2 \cos^2 u \sin v, -4 \cos u \sin u]. \end{aligned}$$

The inner product is

$$\mathbf{F} \cdot \mathbf{N} = (-2 \cos^2 u)(\cos v + \sin v) - 4a \cos u \sin u.$$

Integration of  $\cos v + \sin v$  over  $v$  from 0 to  $2\pi$  gives 0. Integration of  $-4a \cos u \sin u$  over  $u$  from 0 to  $\pi/2$  gives  $-2a$ . Integration of this constant over  $v$  from 0 to  $2\pi$  gives  $-4\pi a$  (or  $+4\pi a$  if we change the orientation by interchanging  $u$  and  $v$ ).

34. By Gauss's theorem.  $T$  can be represented by

$$\mathbf{r} = [r \cos u, r \sin u, v], \quad \text{where} \quad 0 \leq r \leq 1, 0 \leq u \leq 2\pi, 0 \leq v \leq h.$$

The divergence of  $\mathbf{F}$  is

$$\operatorname{div} \mathbf{F} = 1 + x + 1 = 2 + x = 2 + r \cos u.$$

The integrand is  $(2 + r \cos u)r$ . Integration over  $r$  from 0 to 1 gives  $1 + \frac{1}{3} \cos u$ . Integration of this over  $u$  from 0 to  $2\pi$  gives  $2\pi$ . Integration of this over  $v$  from 0 to  $h$  gives the answer  $2\pi h$ . Note that this is the integral of the term 2 in  $\operatorname{div} \mathbf{F}$ , whereas  $r \cos u$  gives 0.

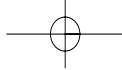

To check this against Prob. 33, add to the answer  $\pi h$  of Prob. 33 the contributions of the disks  $D_h: x^2 + y^2 \leq 1, z = h$ , and  $D_0: x^2 + y^2 \leq 1, z = 0$ .

For  $D_h$  we have

$$\mathbf{r} = [r \cos u, r \sin u, h], \quad \mathbf{N} = [0, 0, 1]$$

and furthermore,

$$\mathbf{F} = [r \cos u, r^2 \cos u \sin u, h].$$

Hence  $\mathbf{F} \cdot \mathbf{N} = h$ . Integration of this constant over  $x^2 + y^2 \leq 1$  gives  $\pi h$ . For  $D_0$  we obtain

$$\mathbf{r} = [r \cos u, r \sin u, 0], \quad \mathbf{N} = [0, 0, -1].$$

Hence

$$\mathbf{F} \cdot \mathbf{N} = [r \cos u, r^2 \cos u \sin u, 0] \cdot [0, 0, -1] = 0$$

and we obtain the contribution 0. Together,  $\pi h + \pi h = 2\pi h$ , in agreement with the answer to Prob. 34.

# Part C. FOURIER ANALYSIS. PARTIAL DIFFERENTIAL EQUATIONS (PDEs)

## CHAPTER 11 Fourier Series, Integrals, and Transforms

### Change

The first two sections are now combined into a single section, giving a better and somewhat faster start, with more emphasis on the essential ideas and facts.

### SECTION 11.1. Fourier Series, page 478

**Purpose.** To derive the Euler formulas (6) for the coefficients of a Fourier series (5) of a given function of period  $2\pi$ , using as the key property the orthogonality of the trigonometric system.

#### Main Content, Important Concepts

- Periodic function
- Trigonometric system, its orthogonality (Theorem 1)
- Fourier series (5) with Fourier coefficients (6)
- Representation by a Fourier series (Theorem 2)

#### Comment on Notation

If we write  $a_0/2$  instead of  $a_0$  in (1), we must do the same in (6a) and see that (6a) then becomes (6b) with  $n = 0$ . This is merely a small notational convenience (but may be a source of confusion to poorer students).

#### Comment on Fourier Series

Whereas their theory is quite involved, practical applications are simple, once the student has become used to evaluating integrals in (6) that depend on  $n$ .

Figure 257 should help students understand why and how a series of continuous terms can have a discontinuous sum.

#### Comment on the History of Fourier Series

Fourier series were already used in special problems by Daniel Bernoulli (1700–1782) in 1748 (vibrating string, Sec. 12.3) and Euler (Sec. 2.5) in 1754. Fourier's book of 1822 became the source of many mathematical methods in classical mathematical physics. Furthermore, the surprising fact that Fourier series, whose terms are *continuous* functions, may represent *discontinuous* functions led to a reflection on, and generalization of, the concept of a function in general. Hence the book is a landmark in both pure and applied mathematics. [That surprising fact also led to a controversy between Euler and D. Bernoulli over the question of whether the two types of solution of the vibrating string problem (Secs. 12.3 and 12.4) are identical; for details, see E. T. Bell, *The Development of Mathematics*, New York: McGraw-Hill, 1940, p. 482.] A mathematical theory of Fourier series was started by Peter Gustav Lejeune Dirichlet (1805–1859) of Berlin in 1829. The concept of the Riemann integral also resulted from work on Fourier series. Later on, these series became the model case in the theory of orthogonal functions (Sec. 5.7). An English translation of Fourier's book was published by Dover Publications in 1955.

**SOLUTIONS TO PROBLEM SET 11.1, page 485**

2.  $2\pi, 2\pi, \pi, \pi, 2, 2, 1, 1$   
 4. There is no *smallest*  $p > 0$ .  
 6.  $f(x + p) = f(x)$  implies

$$f(ax + p) = f(a[x + (p/a)]) = f(ax) \text{ or } g[x + (p/a)] = g(x),$$

where

$$g(x) = f(ax).$$

Thus  $g(x)$  has the period  $p/a$ . This proves the first statement. The other statement follows by setting  $a = 1/b$ .

- 8.–12. These problems should familiarize the student with the kind of periodic functions, some of them discontinuous, that occur in applications as driving forces in mechanics, as boundary potentials in electrostatics or heat conduction, in high-frequency problems in connection with filters, and so on. Functions of this type will occur throughout this chapter and the next one.

14.  $\frac{1}{2} + \frac{2}{\pi} (\sin x + \frac{1}{3} \sin 3x + \frac{1}{5} \sin 5x + \cdots)$ .  $f(x) - \frac{1}{2}$  is odd.  
 16.  $\frac{2}{\pi} (\sin x - \frac{1}{9} \sin 3x + \frac{1}{25} \sin 5x - \cdots) + \frac{1}{2} \sin 2x - \frac{1}{4} \sin 4x + \frac{1}{6} \sin 6x - \cdots$   
 18.  $\frac{\pi}{2} - \frac{4}{\pi} (\cos x + \frac{1}{9} \cos 3x + \frac{1}{25} \cos 5x + \cdots)$ . See also Prob. 15.  
 20.  $\frac{1}{\pi} [(2 + \pi) \sin x + \frac{1}{9} (-2 + 3\pi) \sin 3x + \frac{1}{25} (2 + 5\pi) \sin 5x + \cdots]$   
 $\quad - \frac{1}{2} \sin 2x - \frac{1}{4} \sin 4x - \frac{1}{6} \sin 6x - \cdots$   
 22.  $\frac{4}{3}\pi^2 + 4(\cos x + \frac{1}{4} \cos 2x + \frac{1}{9} \cos 3x + \cdots)$   
 $\quad - 4\pi(\sin x + \frac{1}{2} \sin 2x + \frac{1}{3} \sin 3x + \cdots)$   
 24.  $2\pi - \frac{16}{\pi} (\cos x + \frac{1}{9} \cos 3x + \frac{1}{25} \cos 5x + \cdots)$

26. **CAS Experiment. Experimental approach to Fourier series.** This should help the student obtain a feel for the kind of series to expect in practice, and for the kind and quality of convergence, depending on continuity properties of the sum of the series.

(a)  $f(x) = x$  has discontinuities at  $\pm\pi$ . The instructor will notice the beginning of the **Gibbs phenomenon** (to be discussed in Problem Set 11.2) at the points of discontinuity.

(b)  $f(x) = 1 + x/\pi$  if  $-\pi < x < 0$  and  $1 - x/\pi$  if  $0 < x < \pi$ , is continuous throughout, and the accuracy is much better than in (a).

(c)  $f(x) = \pi^2 - x^2$  has about the same continuity as (b), and the approximation is good.

The coefficients in (a) involve  $1/n$ , whereas those in (b) and (c) involve  $1/n^2$ . This is typical. See also CAS Experiment 27.

28. **Project.** Integrate by parts.  $a_0$  is obtained as before. The formulas extend to any function for which the derivatives are identically zero from some derivative on. Jumps may occur at points where the representation of  $f(x)$  changes, and at the ends  $\pm\pi$  of the interval. Accordingly, we write the integral in the Euler formula for  $a_n$  as a sum of integrals,

$$\pi a_n = \int_{-\pi}^{\pi} f \cos nx \, dx = \int_{x_0}^{x_1} + \int_{x_1}^{x_2} + \cdots + \int_{x_{m-1}}^{x_m} = \sum_{s=1}^m \int_{x_{s-1}}^{x_s} f \cos nx \, dx$$

where  $x_0 = -\pi$  and  $x_m = \pi$ . Integration by parts gives

$$\int_{x_{s-1}}^{x_s} f \cos nx \, dx = \frac{f}{n} \sin nx \Big|_{x_{s-1}}^{x_s} - \frac{1}{n} \int_{x_{s-1}}^{x_s} f' \sin nx \, dx.$$

Now comes an important point: the evaluation of the first expression on the right.  $f(x)$  may be discontinuous at  $x_s$  and we have to take the left-hand limit  $f(x_s - 0)$  of  $f$  at  $x_s$ . Similarly, at  $x_{s-1}$  we have to take the right-hand limit  $f(x_{s-1} + 0)$ . Hence the first expression on the right equals

$$\frac{1}{n} [f(x_s - 0) \sin nx_s - f(x_{s-1} + 0) \sin nx_{s-1}].$$

Consequently, by inserting this into  $a_m$  and using the short notations  $S_0 = \sin nx_0$ ,  $S_1 = \sin nx_1$ , etc., we obtain

$$\begin{aligned} \pi a_n = \frac{1}{n} [ & f(x_1 - 0)S_1 - f(x_0 + 0)S_0 + f(x_2 - 0)S_2 - f(x_1 + 0)S_1 \\ & + \cdots + f(x_m - 0)S_m - f(x_{m-1} + 0)S_{m-1}] \\ & - \frac{1}{n} \sum_{s=1}^m \int_{x_{s-1}}^{x_s} f' \sin nx \, dx. \end{aligned}$$

Collecting terms with the same  $S$  the expression in brackets becomes

$$\begin{aligned} & -f(x_0 + 0)S_0 + [f(x_1 - 0) - f(x_1 + 0)]S_1 \\ & + [f(x_2 - 0) - f(x_2 + 0)]S_2 + \cdots + f(x_m - 0)S_m. \end{aligned}$$

The expressions in the brackets are the jumps of  $f$ , multiplied by  $-1$ . Furthermore, because of periodicity,  $S_0 = S_m$  and  $f(x_0) = f(x_m)$ , so that we may combine the first and the last term,

$$-j_1 S_1 - j_2 S_2 - \cdots - j_m S_m,$$

and we therefore have the intermediate result

$$\pi a_n = -\frac{1}{n} \sum_{s=1}^m j_s \sin nx_s - \frac{1}{n} \sum_{s=1}^m \int_{x_{s-1}}^{x_s} f' \sin nx \, dx.$$

By applying the same procedure to the integrals on the right we find

$$\sum_{s=1}^m \int_{x_{s-1}}^{x_s} f' \sin nx \, dx = \frac{1}{n} \sum_{s=1}^m j'_s \cos nx_s + \frac{1}{n} \sum_{s=1}^m \int_{x_{s-1}}^{x_s} f'' \cos nx \, dx.$$

By applying the procedure once more, namely, to the integral on the right, we obtain the “jump formula” for  $a_n$ . For the  $b_n$  the process is the same. If a derivative of  $f$  higher than the second is not identically zero, we have to do additional steps. The number of steps is finite as long as  $f(x)$  is piecewise polynomial. For other functions, since partial integration brings in increasingly higher powers of  $1/n$ , it may be worthwhile to investigate what happens if one terminates the process prematurely, after finitely many steps.

- 30. CAS Experiment.** The student should recognize the importance of the interval in connection with orthogonality, which is the basic concept in the derivation of the Euler formulas.

For instance, for  $\sin 3x \sin 4x$  the integral equals  $\sin a - \frac{1}{7} \sin 7a$ , and the graph suggests orthogonality for  $a = \pi$ , as expected.

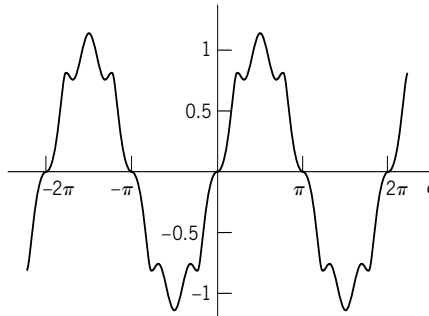
Section 11.1. Integral in Problem 30 as a function of  $a$ **SECTION 11.2. Functions of Any Period  $p = 2L$ , page 487**

**Purpose.** It is practical to start with functions of period  $2\pi$ , as we have done, because in this case the Euler formulas and Fourier series look much simpler. And this is practically no detour because the general case of  $p = 2L$  is obtained simply by a linear transformation on the  $x$ -axis, giving the Fourier series (5) with coefficients (6).

The notation  $p = 2L$  is suggested by the fact that we shall later use **half-range expansions**, with the series used “physically” only on an interval from  $x = 0$  to  $L$  (the extension of a vibrating string or a beam in heat conduction problems, etc.).

**SOLUTIONS TO PROBLEM SET 11.2, page 490**

$$2. 2 + \frac{8}{\pi} \left( \sin \frac{\pi x}{2} + \frac{1}{3} \sin \frac{3\pi x}{2} + \frac{1}{5} \sin \frac{5\pi x}{2} + \cdots \right)$$

$$4. \left( 1 - \frac{6}{\pi^2} \right) \sin \pi x - \left( \frac{1}{2} - \frac{6}{2^3 \pi^2} \right) \sin 2\pi x + \left( \frac{1}{3} - \frac{6}{3^3 \pi^2} \right) \sin 3\pi x - + \cdots$$

6. Full-wave rectification of a cosine current,

$$\frac{2}{\pi} + \frac{4}{\pi} \left( \frac{1}{1 \cdot 3} \cos 2\pi x - \frac{1}{3 \cdot 5} \cos 4\pi x + \frac{1}{5 \cdot 7} \cos 6\pi x - + \cdots \right)$$

$$8. \frac{1}{2} + \frac{4}{\pi^2} \left( \cos \pi x + \frac{1}{9} \cos 3\pi x + \frac{1}{25} \cos 5\pi x + \cdots \right)$$

$$10. \frac{1}{2} - \frac{4}{\pi^2} \left( \cos \frac{\pi x}{2} + \frac{1}{9} \cos \frac{3\pi x}{2} + \frac{1}{25} \cos \frac{5\pi x}{2} + \cdots \right) \\ + \frac{2}{\pi} \left( \sin \frac{\pi x}{2} - \frac{1}{2} \sin \frac{2\pi x}{2} + \frac{1}{3} \sin \frac{3\pi x}{2} - \frac{1}{4} \sin \frac{4\pi x}{2} + - \cdots \right)$$

$$12. b_n = 0, a_0 = \frac{V_0}{\pi},$$

$$a_n = 100V_0 \int_{-1/200}^{1/200} \cos 100\pi t \cos 100n\pi t \, dt \\ = 50V_0 \int_{-1/200}^{1/200} \cos 100(n+1)\pi t \, dt + 50V_0 \int_{-1/200}^{1/200} \cos 100(n-1)\pi t \, dt,$$



$$\frac{V_0}{\pi} + \frac{V_0}{2} \cos 100\pi t + \frac{2V_0}{\pi} \left( \frac{1}{1 \cdot 3} \cos 200\pi t - \frac{1}{3 \cdot 5} \cos 400\pi t + \frac{1}{5 \cdot 7} \cos 600\pi t - + \dots \right)$$

14. Multiply by  $-1$  and add 1.

16. In Prob. 21 of Sec. 11.1, write  $t$  for  $x$ ; then

$$\tilde{f}(t) = t^2 = \frac{\pi^2}{3} - 4 \left( \cos t - \frac{1}{4} \cos 2t + - \dots \right).$$

Now set  $t = \pi x$  to get  $\tilde{f}(t) = \pi^2 x^2$ , which shows that the series should be multiplied by  $1/\pi^2$  to get that of

$$f(x) = x^2 = \frac{1}{3} - \frac{4}{\pi^2} \left( \cos \pi x - \frac{1}{4} \cos 2\pi x + - \dots \right).$$

18. Set  $x = 1$  in Prob. 3 to get  $1 = \frac{1}{3} - \frac{4}{\pi^2} \left( -1 - \frac{1}{4} - \frac{1}{9} - \dots \right)$ , etc.

20. **CAS Experiment.** The figure shows  $s_{50}$  in Prob. 10.

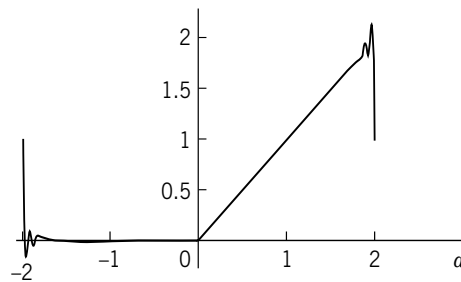

Section 11.2. Gibbs phenomenon in CAS Experiment 20

### SECTION 11.3. Even and Odd Functions. Half-Range Expansions, page 490

**Purpose. 1.** To show that a Fourier series of an even function (an odd function) has only cosine terms (only sine terms), so that unnecessary work and sources of errors are avoided.

**2.** To represent a function  $f(x)$  by a Fourier cosine series or by a Fourier sine series (of period  $2L$ ) if  $f(x)$  is given on an interval  $0 \leq x \leq L$  only, which is half the interval of periodicity—hence the name “half-range.”

#### Comment

Such half-range expansions occur in vibrational problems, heat problems, etc., as will be shown in Chap. 12.

### SOLUTIONS TO PROBLEM SET 11.3, page 496

2. Even, even, even, even, neither even nor odd, neither even nor odd, odd, odd
4. Neither even nor odd
6. Even

8. Neither even nor odd

10. **Project.** (a) Sums and products of even functions are even. Sums of odd functions are odd. Products of odd functions are odd (even) if the number of their factors is odd (even). Products of an even times an odd function are odd. This is important in connection with the integrands in the Euler formulas for the Fourier coefficients. Absolute values of odd functions are even.  $f(x) + f(-x)$  is even,  $f(x) - f(-x)$  is odd.

$$(b) e^{kx} = \cosh kx + \sinh kx, \frac{1}{1-x} = \frac{1}{1-x^2} + \frac{x}{1-x^2}; \text{ furthermore,}$$

$$\sin(x+k) = \sin k \cos x + \cos k \sin x,$$

$$\cosh(x+k) = \cosh k \cosh x + \sinh k \sinh x.$$

(c)  $f(-x) = -f(x)$  and  $f(-x) = f(x)$  together imply  $f = 0$ .

(d)  $\cos^3 x$  is even,  $\sin^3 x$  is odd. The Fourier series are the familiar identities

$$\cos^3 x = \frac{3}{4} \cos x + \frac{1}{4} \cos 3x \quad \text{and} \quad \sin^3 x = \frac{3}{4} \sin x - \frac{1}{4} \sin 3x.$$

See also Prob. 13 in Sec. 11.2.

$$12. \frac{4}{\pi^3} \left( (\pi^2 - 4) \sin \pi x + \frac{1}{27} (9\pi^2 - 4) \sin 3\pi x + \frac{1}{125} (25\pi^2 - 4) \sin 5\pi x + \cdots \right) \\ - \frac{2}{\pi} \left( \sin 2\pi x + \frac{1}{2} \sin 4\pi x + \frac{1}{3} \sin 6\pi x + \cdots \right)$$

$$14. e^\pi - 1 - (e^\pi + 1) \cos x + \frac{2}{5} (e^\pi - 1) \cos 2x - \frac{1}{5} (e^\pi + 1) \cos 3x \\ + \frac{2}{17} (e^\pi - 1) \cos 4x - + \cdots$$

$$16. \frac{1}{4} + \frac{4}{\pi^2} \left( \cos \frac{\pi x}{4} + \frac{1}{2} \cos \frac{2\pi x}{4} + \frac{1}{9} \cos \frac{3\pi x}{4} + \frac{1}{25} \cos \frac{5\pi x}{4} \right. \\ \left. + \frac{1}{18} \cos \frac{6\pi x}{4} + \frac{1}{49} \cos \frac{7\pi x}{4} + \cdots \right)$$

$$18. (a) \frac{1}{4} - \frac{2}{\pi^2} \left( \cos 2\pi x + \frac{1}{9} \cos 6\pi x + \frac{1}{25} \cos 10\pi x + \frac{1}{49} \cos 14\pi x + \cdots \right)$$

$$(b) \frac{1}{\pi} \left( \sin 2\pi x - \frac{1}{2} \sin 4\pi x + \frac{1}{3} \sin 6\pi x - \frac{1}{4} \sin 8\pi x + - \cdots \right)$$

$$20. (a) \frac{1}{2} - \frac{2}{\pi} \left( \cos \frac{\pi x}{4} - \frac{1}{3} \cos \frac{3\pi x}{4} + \frac{1}{5} \cos \frac{5\pi x}{4} - + \cdots \right)$$

$$(b) \frac{2}{\pi} \left( \sin \frac{\pi x}{4} - \sin \frac{\pi x}{2} + \frac{1}{3} \sin \frac{3\pi x}{4} + \frac{1}{5} \sin \frac{5\pi x}{4} - \frac{1}{3} \sin \frac{3\pi x}{2} \right. \\ \left. + \frac{1}{7} \sin \frac{7\pi x}{4} + \frac{1}{9} \sin \frac{9\pi x}{4} - \frac{1}{5} \sin \frac{5\pi x}{2} + \frac{1}{11} \sin \frac{11\pi x}{4} + \cdots \right)$$

$$22. (a) \frac{3\pi}{8} - \frac{2}{\pi} \left( \cos x + \frac{1}{2} \cos 2x + \frac{1}{9} \cos 3x + \frac{1}{25} \cos 5x + \frac{1}{18} \cos 6x \right. \\ \left. + \frac{1}{49} \cos 7x + \frac{1}{81} \cos 9x + \frac{1}{50} \cos 10x + \frac{1}{121} \cos 11x + \cdots \right)$$

$$(b) \left(1 + \frac{2}{\pi}\right) \sin x - \frac{1}{2} \sin 2x + \left(\frac{1}{3} - \frac{2}{9\pi}\right) \sin 3x - \frac{1}{4} \sin 4x \\ + \left(\frac{1}{5} + \frac{2}{25\pi}\right) \sin 5x - \frac{1}{6} \sin 6x + \left(\frac{1}{7} - \frac{2}{49\pi}\right) \sin 7x + \cdots$$

The student should be invited to find the two functions that the sum of the series represents. This can be done by graphing  $\sin x - \frac{1}{2} \sin 2x + \frac{1}{3} \sin 3x + \cdots = x/2$  and then  $(2/\pi)(\sin x - 3^{-2} \sin 3x + \cdots) = f_2$ , where

$$f_2(x) = \begin{cases} x/2 & \text{if } -\pi/2 < x < \pi/2 \\ \pi/2 - x/2 & \text{if } \pi/2 < x < 3\pi/2. \end{cases}$$

The first of these functions is discontinuous, the coefficients being proportional to  $1/n$ , whereas  $f_2$  is continuous, its Fourier coefficients being proportional to  $1/n^2$ , so that they go to zero much faster than the others.

$$24. (a) \frac{L^2}{3} - \frac{4L^2}{\pi^2} \left( \cos \frac{\pi x}{L} - \frac{1}{4} \cos \frac{2\pi x}{L} + \frac{1}{9} \cos \frac{3\pi x}{L} \right. \\ \left. - \frac{1}{16} \cos \frac{4\pi x}{L} + \cdots \right).$$

$$(b) \frac{2L^2}{\pi} \left[ \left(1 - \frac{4}{\pi^2}\right) \sin \frac{\pi x}{L} - \frac{1}{2} \sin \frac{2\pi x}{L} + \left(\frac{1}{3} - \frac{4}{3^3\pi^2}\right) \sin \frac{3\pi x}{L} \right. \\ \left. - \frac{1}{4} \sin \frac{4\pi x}{L} + \cdots \right]$$

The coefficients of the cosine series are proportional to  $n^{-2}$ , reflecting the fact that the sum is continuous. The coefficients of the sine series are proportional to  $n^{-1}$ , so that they go to zero more slowly, reflecting the fact that the sum of the series is discontinuous.

$$26. \int_{-L}^L g(x) dx = \int_{-L}^0 g(t) dt + \int_0^L g(x) dx = - \int_L^0 g(-x) dx + \int_0^L g(x) dx. \text{ Here } t = -x.$$

Using that  $g(x)$  is even, we obtain

$$\int_0^L g(-x) dx + \int_0^L g(x) dx = 2 \int_0^L g(x) dx.$$

#### SECTION 11.4. Complex Fourier Series. *Optional*, page 496

**Purpose.** To show that the formula for  $e^{i\theta}$  or direct derivation leads to the complex Fourier series in which complex exponential functions (instead of cosine and sine) appear. This is interesting, but will not be needed in our further work, so that we can leave it optional.

**Short Courses.** Sections 11.4–11.9 can be omitted.

#### SOLUTIONS TO PROBLEM SET 11.4, page 499

2. Direct consequence of (5).

8. Combine the terms pairwise ( $n = 0, n = -1$ ), ( $n = 1, n = -2$ ), etc. to obtain

$$- \frac{2i}{\pi} \left( 2i \sin x + \frac{2i}{3} \sin 3x + \cdots \right) = \frac{4}{\pi} \left( \sin x + \frac{1}{3} \sin 3x + \cdots \right)$$

as in Sec. 11.1, Example 1, with  $k = 1$ .

10.  $i(e^{inx} - e^{-inx}) = -2 \sin nx$ , and  $(-1)^n$  gives the signs as expected,

$$2(\sin x - \frac{1}{2} \sin 2x + \frac{1}{3} \sin 3x - + \dots).$$

12.  $e^{inx} + e^{-inx} = 2 \cos nx$ , and  $2 \cdot 2$  gives the factor 4 in

$$\frac{\pi^2}{3} - 4 \left( \cos x - \frac{1}{4} \cos 2x + \frac{1}{9} \cos 3x - \frac{1}{16} \cos 4x + \dots \right).$$

14. **Project.** When  $n = m$ , the integrand of the integral on the right is  $e^0 = 1$ , so that the integral equals  $2\pi$ . This gives

$$\int_{-\pi}^{\pi} f(x) e^{-imx} dx = 2\pi c_m$$

provided the other integrals are zero, which is true by (3b),

$$\begin{aligned} \int_{-\pi}^{\pi} e^{i(n-m)x} dx &= \frac{1}{i(n-m)} (e^{i(n-m)\pi} - e^{-(n-m)\pi}) \\ &= \frac{1}{i(n-m)} 2i \sin(n-m)\pi = 0. \end{aligned}$$

Now writing  $n$  for  $m$  in (A) gives the coefficient formula in (6).

### SECTION 11.5. Forced Oscillations, page 499

**Purpose.** To show that mechanical or electrical systems with periodic but nonsinusoidal input may respond predominantly to one of the infinitely many terms in the Fourier series of the input, giving an unexpected output; see Fig. 274, where the output frequency is essentially five times that of the input.

**Short Courses.** Sections 11.4–11.9 can be omitted.

### SOLUTIONS TO PROBLEM SET 11.5, page 501

2. For  $k = 9$  the amplitude  $C_3 = 0.943$  is largest, larger than  $C_1$  by a factor 6. For  $k = 81$  the amplitude  $C_9 = 0.0349$  is largest; second is  $C_1 = 0.0159$ .
4.  $r'(t)$  is given by the sine series in Example 1 of Sec. 11.1 with  $k = -1$ . The new  $C_n$  is  $n$  times the old one, so that  $C_5$  is so large that the output is practically a cosine vibration having five times the input frequency.

$$6. y = c_1 \cos \omega t + c_2 \sin \omega t + \frac{1}{\omega^2 - \omega_1^2} \cos \omega_1 t + \frac{1}{\omega^2 - \omega_2^2} \cos \omega_2 t$$

$$8. y = c_1 \cos \omega t + c_2 \sin \omega t + \frac{1}{\omega^2 - 1} \sin t + \frac{1/3}{\omega^2 - 9} \sin 3t + \frac{1/5}{\omega^2 - 25} \sin 5t \\ + \frac{1/7}{\omega^2 - 49} \sin 7t$$

$$10. y = c_1 \cos \omega t + c_2 \sin \omega t + \frac{4}{\pi} \left( \frac{1}{\omega^2 - 1} \sin t - \frac{1/9}{\omega^2 - 9} \sin 3t \\ + \frac{1/25}{\omega^2 - 25} \sin 5t - + \dots \right)$$

$$14. y = \frac{1 - n^2}{D_n} a_n \cos nt + \frac{nc}{D_n} a_n \sin nt, \quad D_n = (1 - n^2)^2 + n^2 c^2$$

$$16. y = A_1 \cos t + B_1 \sin t + A_3 \cos 3t + B_3 \sin 3t + \cdots, \text{ where}$$

$$A_n = -4ncb_n/D_n, \quad B_n = 4(1 - n^2)b_n/D_n, \quad D_n = (1 - n^2)^2 + n^2 c^2$$

$b_1 = 1, b_2 = 0, b_3 = -1/9, b_4 = 0, b_5 = 1/25, \dots$ . The damping constant  $c$  appears in the cosine terms, causing a phase shift, which is 0 if  $c = 0$ . Also,  $c$  increases  $D_n$ ; hence it decreases the amplitudes, which is physically understandable.

$$18. C_n = \sqrt{A_n^2 + B_n^2} = 4/(n^2 \pi \sqrt{D_n}), \quad D_n = (n^2 - k)^2 + n^2 c^2 \text{ with } A_n \text{ and } B_n \text{ obtained as solutions of}$$

$$\begin{aligned} (k - n^2)A_n + ncB_n &= 4/n^2 \pi \\ -ncA_n + (k - n^2)B_n &= 0. \end{aligned}$$

$$20. I = \sum_{n=1}^{\infty} (A_n \cos nt + B_n \sin nt),$$

$$A_n = \frac{80(10 - n^2)}{\pi n^2 D_n}, \quad B_n = \frac{800}{n \pi D_n} \quad (n \text{ odd}),$$

$$A_n = 0, B_n = 0 \quad (n \text{ even}), \quad D_n = (10 - n^2)^2 + 100 n^2; \text{ hence}$$

$$\begin{aligned} I &= 1.266 \cos t + 1.406 \sin t + 0.003 \cos 3t + 0.094 \sin 3t \\ &\quad - 0.006 \cos 5t + 0.019 \sin 5t - 0.003 \cos 7t + 0.006 \sin 7t \\ &\quad - 0.002 \cos 9t + 0.002 \sin 9t - 0.001 \cos 11t + 0.001 \sin 11t + \cdots \end{aligned}$$

## SECTION 11.6. Approximation by Trigonometric Polynomials, page 502

**Purpose.** We show how to find “best” approximations of a given function by trigonometric polynomials of a given degree  $N$ .

### Important Concepts

Trigonometric polynomial

Square error, its minimum (6)

Bessel's inequality, Parseval's identity

**Short Courses.** Sections 11.4–11.9 can be omitted.

### Comment on Quality of Approximation

This quality can be measured in many ways. Particularly important are (i) the absolute value of the maximum deviation over a given interval, and (ii) the mean square error considered here. See Ref. [GR7] in App. 1.

## SOLUTIONS TO PROBLEM SET 11.6, page 505

$$2. F = \frac{\pi^2}{3} - 4 \left( \cos x - \frac{1}{4} \cos 2x + \frac{1}{9} \cos 3x - + \cdots + \frac{(-1)^{N+1}}{N^2} \cos Nx \right);$$

$$E^* = 4.14, 1.00, 0.38, 0.18, 0.10$$

$$4. F = 2[(\pi^2 - 6) \sin x - \frac{1}{8}(4\pi^2 - 6) \sin 2x + \frac{1}{27}(9\pi^2 - 6) \sin 3x - + \cdots]; E^* = 674.8, 454.7, 336.4, 265.6, 219.0. \text{ The coefficients are proportional to } 1/n. \text{ Accordingly, } E^* \text{ decreases slowly; it is } 59.64 (N = 20), 30.22 (N = 40), \text{ etc.}$$

6.  $F = A + B \cos x + \frac{2}{5}A \cos 2x + \frac{1}{5}B \cos 3x + \frac{2}{17}A \cos 4x + \cdots$ , where  $A = (1 - e^{-\pi})/\pi$ ,  $B = (1 + e^{-\pi})/\pi$ ,  $E^* = 0.06893, 0.02231, 0.00845, 0.00442, 0.00237$ . For  $N = 20$  we have  $4.9 \cdot 10^{-5}$ .

8. We obtain

$$F = \frac{2}{\pi} \sin x + \frac{1}{2} \sin 2x - \frac{2}{9\pi} \sin 3x - \frac{1}{4} \sin 4x + \frac{2}{25\pi} \sin 5x + \frac{1}{6} \sin 6x + \cdots$$

The values of  $E^*$  are

$$1.3106, 0.5252, 0.5095, 0.3132, 0.3111, 0.2238, 0.2233, 0.1742, 0.1740, \cdots$$

Their interesting way of decreasing reflects that some of the Fourier coefficients involve  $1/n^2$  and others involve  $1/n$ .

10. **CAS Experiment.** Factors are the continuity or discontinuity and the speed with which the coefficients go to zero,  $1/n$ ,  $1/n^2$ .

For  $f(x)$  given on  $-\pi < x < \pi$  some data are as follows ( $f$ , decrease of the coefficients, continuity or not, smallest  $N$  such that  $E^* < 0.1$ ).

$$f = x, 1/n, \text{ discontinuous, } N = 126$$

$$f = x^2, 1/n^2, \text{ continuous, } N = 5$$

$$f = x^3, 1/n^2, \text{ discontinuous. } E^* = 6.105 \text{ for } N = 200$$

$$f = x^4, 1/n, \text{ continuous, } N = 40$$

$$f = x^6, 1/n, \text{ continuous. For } N = 200 \text{ we still have } E^* = 0.1769.$$

For  $f$  in Prob. 5 we have  $1/n^2$ , continuity,  $N = 2$ . In Prob. 9 we have  $1/n^3$ , continuity, and  $N = 1$ .

The functions

$$f(x) = \begin{cases} (x + \frac{1}{2}\pi)^{2k} - (\frac{1}{2}\pi)^{2k} & \text{if } -\pi < x < 0 \\ -(-x - \frac{1}{2}\pi)^{2k} + (\frac{1}{2}\pi)^{2k} & \text{if } 0 < x < \pi \end{cases}$$

with  $k = 1, 2, 3, 4$  have coefficients proportional to  $1/n^2$  and  $E^* < 0.1$  when  $N \geq 1$  ( $k = 1$ ), 5 ( $k = 2$ ), 11 ( $k = 3$ ), 21 ( $k = 4$ ).

These data indicate that the whole situation is more complex than one would at first assume. So the student may need your help and guidance.

## SECTION 11.7. Fourier Integral, page 506

**Purpose.** Beginning in this section, we show how ideas from Fourier series can be extended to nonperiodic functions defined on the real line, leading to integrals instead of series.

### Main Content, Important Concepts

Fourier integral (5)

Existence Theorem 1

Fourier cosine integral, Fourier sine integral, (10)–(13)

Application to integration

**Short Courses.** Sections 11.4–11.9 can be omitted.

**SOLUTIONS TO PROBLEM SET 11.7, page 512**

2. The integral suggests to use (13). Its value suggests to consider  $f(x) = \pi x/2$  ( $0 < x < 1$ ). Thus  $A(w) = 0$ , and by integration by parts, ( $2/\pi$  cancels),

$$B(w) = \int_0^1 v \sin wv \, dv = \frac{\sin w - w \cos w}{w^2}.$$

At the jump  $x = 1$  the mean of the limits is  $\pi/4$ .

4. The result suggests to consider  $f(x) = \pi/2$  ( $0 \leq x < 1$ ) and to use (11). Then (10) gives

$$A(w) = \int_0^1 \cos wv \, dv = \frac{\sin w}{w}.$$

Note that for  $x = 0$  the integral gives (8\*).

6. Use (13) and  $f(x) = (\pi/2) \sin x$  ( $0 \leq x \leq \pi$ ) to get from (12) with the help of (11) in App. 3.1

$$B(w) = \int_0^\pi \sin v \sin wv \, dv = \frac{\sin \pi w}{1 - w^2}.$$

8.  $A = \frac{2}{\pi} \int_0^a v^2 \cos wv \, dv = \frac{2}{\pi w} \left( a^2 \sin aw - \frac{2}{w^2} \sin aw + \frac{2a}{w} \cos aw \right)$ , so that the answer is

$$\frac{2}{\pi} \int_0^\infty \left[ \left( a^2 - \frac{2}{w^2} \right) \sin aw + \frac{2a}{w} \cos aw \right] \frac{\cos xw}{w} \, dw.$$

Although many students will do the actual integration by their CAS, problems of the present type have the merit of illustrating the ideas of integral representations and transforms, a rather deep and versatile creation, and the techniques involved, such as the proper choice of integration variables and integration limits. Moreover, graphics will help in understanding the transformation process and its properties, for instance, with the help of Prob. 18 or similar experiments.

10.  $A = \frac{2}{\pi} \left( \int_0^1 \frac{v}{2} \cos wv \, dv + \int_1^2 \left( 1 - \frac{v}{2} \right) \cos wv \, dv \right) = \frac{2}{\pi w^2} (\cos w - \cos^2 w)$ ,

so that the answer is

$$\frac{2}{\pi} \int_0^\infty \frac{\cos w - \cos^2 w}{w^2} \cos xw \, dw.$$

12.  $A = \frac{2}{\pi} \int_0^a e^{-v} \cos wv \, dv = \frac{2}{\pi} \left( \frac{1 - e^{-a} (\cos wa - w \sin wa)}{1 + w^2} \right)$ , so that the integral representation is

$$\frac{2}{\pi} \int_0^\infty \frac{1 - e^{-a} (\cos wa - w \sin wa)}{1 + w^2} \cos xw \, dw.$$

14.  $B = \frac{2}{\pi} \int_0^a \sin wv \, dv = \frac{2}{\pi} \left( \frac{1 - \cos aw}{w} \right)$ . Hence the integral representation is

$$\frac{2}{\pi} \int_0^\infty \frac{1 - \cos aw}{w} \sin xw \, dw.$$

16.  $B = \frac{2}{\pi} \int_0^1 (1 - v^2) \sin wv \, dv = \frac{2}{\pi} \cdot \frac{w^2 - 2w \sin w - 2 \cos w + 2}{w^3}$  gives the integral representation

$$\frac{2}{\pi} \int_0^\infty \frac{w^2 - 2w \sin w - 2 \cos w + 2}{w^3} \sin xw \, dw.$$

18.  $B = \frac{2}{\pi} \int_0^\pi \cos v \sin wv \, dv = \frac{2}{\pi} \frac{w(1 + \cos \pi w)}{w^2 - 1}$  gives the integral representation

$$\frac{2}{\pi} \int_0^\infty \frac{w(1 + \cos \pi w)}{w^2 - 1} \sin xw \, dw.$$

Note that the Fourier sine series of the odd periodic extension of  $f(x)$  of period  $2\pi$  has the Fourier coefficients  $b_n = (2/\pi)n(1 + \cos n\pi)/(n^2 - 1)$ . Compare this with  $B$ .

20. **Project.** (a) Formula (a1): Setting  $wa = p$ , we have from (11)

$$f(ax) = \int_0^\infty A(w) \cos axw \, dw = \int_0^\infty A\left(\frac{p}{a}\right) \cos xp \frac{dp}{a}.$$

If we again write  $w$  instead of  $p$ , we obtain (a1).

Formula (a2): From (12) with  $f(v)$  replaced by  $vf(v)$  we have

$$B^*(w) = \frac{2}{\pi} \int_0^\infty vf(v) \sin wv \, dv = -\frac{dA}{dw}$$

where the last equality follows from (10).

Formula (a3) follows by differentiating (10) twice with respect to  $w$ ,

$$\frac{d^2A}{dw^2} = -\frac{2}{\pi} \int_0^\infty f^*(v) \cos wv \, dv, \quad f^*(v) = v^2f(v).$$

(b) In Prob. 7 we have

$$A = \frac{2}{\pi} w^{-1} \sin aw.$$

Hence by differentiating twice we obtain

$$A'' = \frac{2}{\pi} (2w^{-3} \sin aw - 2aw^{-2} \cos aw - a^2w^{-1} \sin aw).$$

By (a3) we now get the result, as before,

$$x^2f(x) = \frac{2}{\pi} \int_0^\infty \left[ \left( -\frac{2}{w^3} + \frac{a^2}{w} \right) \sin aw + \frac{2a}{w^2} \cos aw \right] \cos xw \, dw.$$

(c)  $A(w) = (2 \sin aw)/(\pi w)$ ; see Prob. 7. By differentiation,

$$B^*(w) = -\frac{dA}{dw} = -\frac{2}{\pi} \left( \frac{a \cos aw}{w} - \frac{\sin aw}{w^2} \right).$$

This agrees with the result obtained by using (12). Note well that here we are dealing with a relation between the *two* Fourier transforms under consideration.

(d) The derivation of the following formulas is similar to that of (a1)–(a3).

$$(d1) \quad f(bx) = \frac{1}{b} \int_0^\infty B\left(\frac{w}{b}\right) \sin xw \, dw \quad (b > 0)$$



$$(d2) \quad xf(x) = \int_0^{\infty} C^*(w) \cos xw \, dw, \quad C^*(w) = \frac{dB}{dw}, \quad B \text{ as in (12)}$$

$$(d3) \quad x^2f(x) = \int_0^{\infty} D^*(w) \sin xw \, dw, \quad D^*(w) = -\frac{d^2B}{dw^2}.$$

### SECTION 11.8. Fourier Cosine and Sine Transforms, page 513

**Purpose.** Fourier cosine and sine transforms are obtained immediately from Fourier cosine and sine integrals, respectively, and we investigate some of their properties.

#### Content

Fourier cosine and sine transforms

Transforms of derivatives (8), (9)

#### Comment on Purpose of Transforms

Just as the Laplace transform (Chap. 6), these transforms are designed for solving differential equations. We show this for PDEs in Sec. 12.6.

**Short Courses.** Sections 11.4–11.9 can be omitted.

### SOLUTIONS TO PROBLEM SET 11.8, page 517

2. Integration by parts gives

$$\hat{f}_c(w) = \sqrt{\frac{2}{\pi}} \int_0^k x \cos wx \, dx = \sqrt{\frac{2}{\pi}} \frac{\cos kw + kw \sin kw - 1}{w^2}.$$

4. From (3) and the answer to Prob. 1 we obtain

$$f(x) = \sqrt{\frac{2}{\pi}} \sqrt{\frac{2}{\pi}} \left( \int_0^{\infty} \frac{\sin 2w}{w} \cos wx \, dw - 2 \int_0^{\infty} \frac{\sin w}{w} \cos wx \, dw \right).$$

In the first term set  $2w = v$  to get (a factor 2 cancels and  $(2/\pi)(\pi/2) = 1$ )

$$\frac{2}{\pi} \int_0^{\infty} \frac{\sin v}{v} \cos \left( \frac{vx}{2} \right) dv = \begin{cases} 1 & \text{if } x/2 < 1, \text{ thus } x < 2 \\ 0 & \text{if } x/2 > 1, \text{ thus } x > 2. \end{cases}$$

The second term gives

$$-2 \cdot \frac{2}{\pi} \int_0^{\infty} \frac{\sin w}{w} \cos wx \, dw = \begin{cases} -2 & \text{if } x < 1 \\ 0 & \text{if } x > 1. \end{cases}$$

Adding the two results, we have  $-1$  if  $0 < x < 1$ ,  $1$  if  $1 < x < 2$ ,  $0$  if  $x > 2$ .

6. By integration by parts we obtain

$$f(x) = \sqrt{\frac{2}{\pi}} \int_0^{\infty} e^{-w} \cos wx \, dw = \sqrt{\frac{2}{\pi}} \cdot \frac{1}{1+x^2}.$$

8. Integration by parts gives the answer

$$\sqrt{\frac{2}{\pi}} \frac{2w \cos w + (w^2 - 2) \sin w}{w^3}.$$

10. The defining integrals (2) and (5) have no limit as  $x \rightarrow \infty$ .

12.  $f(x) = e^{-\pi x}$ ,  $f''(x) = \pi^2 f$ ,  $f(0) = 1$ . Hence (9b) gives

$$\mathcal{F}_s(f'') = \pi^2 \mathcal{F}_s(f) = -w^2 \mathcal{F}_s(f) + \sqrt{\frac{2}{\pi}} w.$$

Ordering terms and solving for  $\mathcal{F}_s(f)$  gives

$$(w^2 + \pi^2) \mathcal{F}_s(f) = \sqrt{\frac{2}{\pi}} w, \quad \mathcal{F}_s(f) = \sqrt{\frac{2}{\pi}} \cdot \frac{w}{w^2 + \pi^2}.$$

14.  $\sqrt{\frac{2}{\pi}} \int_0^\pi \sin x \sin wx \, dx = \sqrt{\frac{2}{\pi}} \frac{\sin \pi w}{1 - w^2}$

16. The integrals in this problem and the next one can be reduced to **Fresnel integrals**. This suggests the transformation  $wx = t^2$ . Of course, if one does not see this, one would start with, say,  $wx = v$  and then perhaps remember that the integral of  $v^{-1/2} \sin v$  can be reduced to a Fresnel integral (38) in App. 3.1 by setting  $v = t^2$ . The present calculation is

$$\begin{aligned} \sqrt{\frac{2}{\pi}} \int_0^\infty x^{-1/2} \sin wx \, dx &= \sqrt{\frac{2}{\pi}} \int_0^\infty w^{1/2} t^{-1} (\sin t^2) 2t \, dt w^{-1} \\ &= w^{-1/2} \sqrt{\frac{8}{\pi}} \int_0^\infty \sin t^2 \, dt = w^{-1/2}. \end{aligned}$$

18. The calculation is similar to that in Prob. 16 but requires an additional integration by parts,

$$\begin{aligned} \sqrt{\frac{2}{\pi}} \int_0^\infty x^{-3/2} \sin wx \, dx &= \sqrt{\frac{2}{\pi}} \int_0^\infty w^{3/2} t^{-3} (\sin t^2) w^{-1} 2t \, dt \\ &= \sqrt{\frac{8}{\pi}} w^{1/2} \int_0^\infty t^{-2} \sin t^2 \, dt \\ &= \sqrt{\frac{8}{\pi}} w^{1/2} \left( -t^{-1} \sin t^2 \Big|_0^\infty + \int_0^\infty t^{-1} (\cos t^2) 2t \, dt \right) \\ &= \sqrt{\frac{8}{\pi}} w^{1/2} 2 \sqrt{\frac{\pi}{8}} = 2w^{1/2}. \end{aligned}$$

### SECTION 11.9. Fourier Transform. Discrete and Fast Fourier Transforms, page 518

**Purpose.** Derivation of the Fourier transform from the complex form of the Fourier integral; explanation of its physical meaning and its basic properties.

#### Main Content, Important Concepts

- Complex Fourier integral (4)
- Fourier transform (6), its inverse (7)
- Spectral representation, spectral density
- Transforms of derivatives (9), (10)
- Convolution  $f * g$

#### Comments on Content

The complex Fourier integral is relatively easily obtained from the real Fourier integral in Sec. 11.7, and the definition of the Fourier transform is then immediate.

Note that convolution  $f * g$  differs from that in Chapter 6, and so does the formula (12) in the convolution theorem (we now have a factor  $\sqrt{2\pi}$ ).

**Short Courses.** Sections 11.4–11.9 can be omitted.

### SOLUTIONS TO PROBLEM SET 11.9, page 528

2. By integration of the defining integral we obtain

$$\begin{aligned} \frac{1}{\sqrt{2\pi}} \int_{-\infty}^0 e^{(k-iy)x} dx &= \frac{1}{\sqrt{2\pi}} \cdot \frac{e^{(k-iy)x}}{k-iy} \Big|_{-\infty}^0 \\ &= \frac{1}{\sqrt{2\pi}} \cdot \frac{1}{k-iy}. \end{aligned}$$

4. Integration of the defining integral gives

$$\begin{aligned} \frac{1}{\sqrt{2\pi}} \int_{-1}^1 e^{(2-w)ix} dx &= \frac{-i}{\sqrt{2\pi}(2-w)} (e^{(2-w)i} - e^{-(2-w)i}) \\ &= \frac{-i}{\sqrt{2\pi}(2-w)} 2i \sin(2-w) \\ &= \sqrt{\frac{2}{\pi}} \frac{\sin(w-2)}{w-2}. \end{aligned}$$

6. By integration by parts,

$$\begin{aligned} \frac{1}{\sqrt{2\pi}} \int_{-1}^1 x e^{-iwx} dx &= \frac{1}{\sqrt{2\pi}} \left( \frac{x e^{-iwx}}{-iw} \Big|_{-1}^1 - \frac{1}{-iw} \int_{-1}^1 e^{-iwx} dx \right) \\ &= \frac{1}{\sqrt{2\pi}} \left( \frac{e^{-iw}}{-iw} + \frac{e^{iw}}{-iw} - \frac{1}{(-iw)^2} e^{-iwx} \Big|_{-1}^1 \right) \\ &= \frac{1}{\sqrt{2\pi}} \left( \frac{2 \cos w}{-iw} + \frac{1}{w^2} (e^{-iw} - e^{iw}) \right) \\ &= \sqrt{\frac{2}{\pi}} \left( \frac{i \cos w}{w} - \frac{i \sin w}{w^2} \right) \\ &= \sqrt{\frac{2}{\pi}} \cdot \frac{i}{w^2} (w \cos w - \sin w). \end{aligned}$$

8. By integration by parts we obtain

$$\begin{aligned} \frac{1}{\sqrt{2\pi}} \int_{-1}^0 x e^{-x-iwx} dx &= \frac{1}{\sqrt{2\pi}} \left( \frac{x e^{-(1+iw)x}}{-(1+iw)} \Big|_{-1}^0 + \frac{1}{1+iw} \int_{-1}^0 e^{-(1+iw)x} dx \right) \\ &= \frac{1}{\sqrt{2\pi}} \left( -(-1) \frac{e^{1+iw}}{-(1+iw)} + \frac{e^{-(1+iw)x}}{-(1+iw)(1+iw)} \Big|_{-1}^0 \right) \\ &= \frac{1}{\sqrt{2\pi}} \left( \frac{-e^{1+iw}}{1+iw} - \frac{1-e^{1+iw}}{(1+iw)^2} \right) \\ &= \frac{1}{\sqrt{2\pi}(-w+i)^2} (1 + e^{1+iw}(-1 - i(-w+i))) \\ &= \frac{1}{\sqrt{2\pi}(-w+i)^2} (1 + iwe^{1+iw}). \end{aligned}$$

Problems 1 to 9 should help the student get a feel for integrating complex exponential functions and for their transformation into cosine and sine, as needed in this context. Here, it is taken for granted that complex exponential functions can be handled in the same fashion as real ones, which will be justified in Part D on complex analysis. The problems show that the technicalities are rather formidable for someone who faces these exponential functions for the first time. This is so for relatively simple  $f(x)$ , and since a CAS will give all the results without difficulty, it would make little sense to deal with more complicated  $f(x)$ , which would involve increased technical difficulties but no new ideas.

10.  $f(x) = xe^{-x}$  ( $x > 0$ ),  $g(x) = e^{-x}$  ( $x > 0$ ). Then  $f' = e^{-x} - xe^{-x} = g - f$ , and by (9),

$$iw\mathcal{F}(f) = \mathcal{F}(f') = \mathcal{F}(g) - \mathcal{F}(f)$$

hence

$$(iw + 1)\mathcal{F}(f) = \mathcal{F}(g) = \frac{1}{\sqrt{2\pi}(1 + iw)}, \quad \mathcal{F}(f) = \frac{1}{\sqrt{2\pi}(1 + iw)^2}.$$

12. We obtain

$$\begin{aligned} \frac{i}{\sqrt{2\pi}} \cdot \frac{e^{-ib(a-w)} - e^{ib(a-w)}}{a-w} &= \frac{i}{\sqrt{2\pi}} \cdot \frac{-2i \sin b(a-w)}{a-w} \\ &= \sqrt{\frac{2}{\pi}} \cdot \frac{\sin b(w-a)}{w-a}. \end{aligned}$$

14. **Team Project.** (a) Use  $t = x - a$  as a new variable of integration.  
(b) Use  $c = 3b$ . Then (a) gives

$$e^{2ibw} \mathcal{F}(f(x)) = \frac{e^{ibw} - e^{-ibw}}{iw\sqrt{2\pi}} = \frac{2i \sin bw}{iw\sqrt{2\pi}} = \sqrt{\frac{2}{\pi}} \cdot \frac{\sin bw}{w}.$$

(c) Replace  $w$  with  $w - a$ . This gives a new factor  $e^{iax}$ .

(d) We see that  $\hat{f}(w)$  in formula 7 is obtained from  $\hat{f}(w)$  in formula 1 by replacing  $w$  with  $w - a$ . Hence by (c),  $f(x)$  in formula 1 times  $e^{iax}$  should give  $f(x)$  in formula 7, which is true. Similarly for formulas 2 and 8.

### SOLUTIONS TO CHAP. 11 REVIEW QUESTIONS AND PROBLEMS, page 532

12.  $\frac{1}{2} - \frac{2}{\pi} \left( \cos x - \frac{1}{3} \cos 3x + \frac{1}{5} \cos 5x - + \dots \right)$

14.  $1 - \frac{8}{\pi^2} \left( \cos \frac{\pi x}{2} + \frac{1}{9} \cos \frac{3\pi x}{2} + \frac{1}{25} \cos \frac{5\pi x}{2} + \dots \right)$

16.  $\frac{2}{\pi} \left( \sin \pi x + \frac{1}{2} \sin 2\pi x + \frac{1}{3} \sin 3\pi x + \dots \right)$

18.  $\frac{\sinh \pi}{\pi} \left( 1 - \cos x + \sin x + \frac{2}{5} \cos 2x - \frac{4}{5} \sin 2x + \dots \right)$

20.  $\pi - 2(\sin x + \frac{1}{2} \sin 2x + \frac{1}{3} \sin 3x + \frac{1}{4} \sin 4x + \dots)$

22. 1/2 by Prob. 17. Convergence is slow.

24. From the solution to Prob. 12 we obtain

$$\frac{1}{2} + \frac{4}{\pi^2} \left( 1 + \frac{1}{9} + \frac{1}{25} + \cdots \right) = \frac{1}{\pi} \int_{-\pi/2}^{\pi/2} dx = 1.$$

Hence the answer is  $\pi^2/8$ .

$$26. \frac{2}{\pi} \left( \sin x - \sin 2x + \frac{1}{3} \sin 3x + \frac{1}{5} \sin 5x - \frac{1}{3} \sin 6x + \frac{1}{7} \sin 7x \right. \\ \left. + \frac{1}{9} \sin 9x - \frac{1}{5} \sin 10x + \cdots \right).$$

The sum of

$$- \frac{2}{\pi} \left( \sin 2x + \frac{1}{3} \sin 6x + \frac{1}{5} \sin 10x + \cdots \right)$$

is  $-1/2$  if  $0 < x < \pi/2$  and  $1/2$  if  $\pi/2 < x < \pi$  and periodic with  $\pi$ . The sum of the other terms is the rectangular wave discussed in Sec. 11.1. A sketch of the two functions will explain the connection.

28. 0.2976, 0.2976, 0.1561, 0.1561, 0.1052, 0.1052, 0.0792, 0.0792

$$30. y = 12 \cdot \frac{\sin t}{\omega^2 - 1} - \frac{3}{2} \cdot \frac{\sin 2t}{\omega^2 - 4} + \frac{4}{9} \cdot \frac{\sin 3t}{\omega^2 - 9} - \frac{3}{16} \cdot \frac{\sin 4t}{\omega^2 - 16} + \cdots \\ + C_1 \cos \omega t + C_2 \sin \omega t$$

$$32. \frac{1}{\pi} \int_0^\infty \frac{(\sin 2w - \sin w) \cos wx + (\cos w - \cos 2w) \sin wx}{w} dw$$

$$34. \frac{1}{\pi} \int_0^\infty \frac{1 - \cos 2w}{w^2} \cos wx dw$$

$$36. \frac{4}{\pi} \int_0^\infty \frac{2w^2 + 1 - \cos 2w - 2w \sin 2w}{w^3} \sin wx dw$$

$$38. \frac{k}{\sqrt{2\pi}} \int_a^b e^{-iwx} dx = \frac{k}{\sqrt{2\pi}} \cdot \frac{e^{-iwx}}{-iw} \Big|_{x=a}^b = \frac{ik}{\sqrt{2\pi}} \cdot \frac{e^{-ibw} - e^{-iaw}}{w}$$

$$40. \mathcal{F}_c(f'') = 4\mathcal{F}_c(f) = -w^2 \mathcal{F}_c(f) - \sqrt{\frac{2}{\pi}} f'(0), \quad f'(0) = -2. \quad \text{Hence}$$

$$\mathcal{F}_c(f)(w^2 + 4) = \sqrt{\frac{8}{\pi}}.$$

Now solve for  $\mathcal{F}_c(f)$ .

Similarly, again by two differentiations,

$$\mathcal{F}_s(f'') = 4\mathcal{F}_s(f) = -w^2 \mathcal{F}_s(f) + \sqrt{\frac{2}{\pi}} wf(0), \quad f(0) = 1.$$

Hence

$$\mathcal{F}_s(f)(w^2 + 4) = \sqrt{\frac{2}{\pi}} w \quad \text{and} \quad \mathcal{F}_s(f) = \sqrt{\frac{2}{\pi}} \cdot \frac{w}{w^2 + 4}.$$

## CHAPTER 12 Partial Differential Equations (PDEs)

### SECTION 12.1 Basic Concepts, page 535

**Purpose.** To familiarize the student with the following:

Concept of solution, verification of solutions

Superposition principle for homogeneous linear PDEs

PDEs solvable by methods for ODEs

### SOLUTIONS TO PROBLEM SET 12.1, page 537

2.  $u = c_1(y)e^x + c_2(y)e^{-x}$ .

Problems 1–12 will help the student get used to the notations in this chapter; in particular,  $y$  will now occur as an *independent* variable. Second-order PDEs in this set will also help review the solution methods in Chap. 2, which will play a role in separating variables.

4.  $u = c(x)e^{-y^2}$

6.  $u = c_1(y)e^{-2xy} + c_2(y)e^{2xy}$

8.  $\ln u = 2x \int y \, dy = xy^2 + \tilde{c}(x)$ ,  $u = c(x)e^{xy^2}$

10. Set  $u_y = v$ . Then  $v_y = 4xv$ ,  $v = \tilde{c}_1(x)e^{4xy}$ ; hence

$$u = \int v \, dy = c_1(x)e^{4xy} + c_2(x).$$

12.  $u = (c_1(x) + c_2(x)y)e^{-5y} + \frac{1}{2}y^2e^{-5y}$ . The function on the right is a solution of the homogeneous ODE, corresponding to a double root, so that the last term in the solution involves the factor  $y^2$ .

14.  $c = 1/2$ .

Problems 14–25 should give the student a first impression of what kind of solutions to expect, and of the great variety of solutions compared with those of ODEs. It should be emphasized that although the wave and the heat equations look so similar, their solutions are basically different. It could be mentioned that the boundary and initial conditions are basically different, too. Of course, this will be seen in great detail in later sections, so one should perhaps be cautious not to overload students with such details before they have seen a problem being solved.

16.  $c = 6$

18.  $c = \sqrt{k/32}$

20.  $c = 2$ ,  $\omega$  arbitrary

22. Solutions of the Laplace equation in two dimensions will be derived systematically in complex analysis. Nevertheless, it may be useful to see an unsystematic selection of typical solutions, as given in (7) and in Probs. 23–25.

26. **Team Project.** (a) Denoting derivatives with respect to the entire argument  $x + ct$  and  $x - ct$ , respectively, by a prime, we obtain by differentiating twice

$$u_{xx} = v'' + w'', \quad u_{tt} = v''c^2 + w''c^2$$

and from this the desired result.

- (c) The student should realize that  $u = 1/\sqrt{x^2 + y^2}$  is not a solution of Laplace's equation in two variables. It satisfies the Poisson equation with  $f = (x^2 + y^2)^{-3/2}$ , which seems remarkable.
28. A function whose first partial derivatives are zero is a constant,  $u(x, y) = c = \text{const}$ . Integrate the first PDE and then use the second.
30. Integrating the first PDE and the second PDE gives

$$u = c_1(y)x + c_2(y) \quad \text{and} \quad u = c_3(x)y + c_4(x),$$

respectively. Equating these two functions gives

$$u = axy + bx + cy + k.$$

Alternatively,  $u_{xx} = 0$  gives  $u = c_1(y)x + c_2(y)$ . Then from  $u_{yy} = 0$  we get  $u_{yy} = c_1''x + c_2'' = 0$ ; hence  $c_1'' = 0$ ,  $c_2'' = 0$ , and by integration

$$c_1 = \alpha y + \beta, \quad c_2 = \gamma y + \delta$$

and by substitution in the previous expression

$$u = c_1x + c_2 = \alpha yx + \beta x + \gamma y + \delta.$$

### SECTION 12.2. Modeling: Vibrating String, Wave Equation, page 538

**Purpose.** A careful derivation of the one-dimensional wave equation (more careful than in most other texts, where some of the essential physical assumptions are usually missing).

**Short Courses.** One may perhaps omit the derivation and just state the wave equation and mention of what  $c^2$  is composed.

### SECTION 12.3. Solution by Separating Variables. Use of Fourier Series, page 540

**Purpose.** This first section in which we solve a "big" problem has several purposes:

1. To familiarize the student with the wave equation and with the typical initial and boundary conditions that physically meaningful solutions must satisfy.
2. To explain and apply the important method of separation of variables, by which the PDE is reduced to two ODEs.
3. To show how Fourier series help to get the final answer, thus seeing the reward of our great and long effort in Chap. 11.
4. To discuss the eigenfunctions of the problem, the basic building blocks of the solution, which lead to a deeper understanding of the whole problem.

#### Steps of Solution

1. Setting  $u = F(x)G(t)$  gives two ODEs for  $F$  and  $G$ .
2. The boundary conditions lead to sine and cosine solutions of the ODEs.
3. A series of those solutions with coefficients determined from the Fourier series of the initial conditions gives the final answer.

**SOLUTIONS TO PROBLEM SET 12.3, page 546**

2.  $k(\cos \pi t \sin \pi x - \frac{1}{3} \cos 3\pi t \sin 3\pi x)$

4.  $\frac{12k}{\pi^3} \left( \cos \pi t \sin \pi x - \frac{1}{8} \cos 2\pi t \sin 2\pi x + \frac{1}{27} \cos 3\pi t \sin 3\pi x - + \dots \right)$

6.  $\frac{\sqrt{8}}{\pi^2} \left( \cos \pi t \sin \pi x + \frac{1}{9} \cos 3\pi t \sin 3\pi x - \frac{1}{25} \cos 5\pi t \sin 5\pi x - + \dots \right)$

8.  $\frac{8}{\pi^2} \left( \frac{1}{4} \cos 2\pi t \sin 2\pi x - \frac{1}{36} \cos 6\pi t \sin 6\pi x + \frac{1}{100} \cos 10\pi t \sin 10\pi x - \dots \right)$

There are more graphically posed problems (Probs. 5–10) than in previous editions, so that CAS-using students will have to make at least *some* additional effort in solving these problems.

10.  $\frac{25}{2\pi^2} \left( \sin \frac{\pi}{5} \cos \pi t \sin \pi x - \frac{1}{4} \sin \frac{2\pi}{5} \cos 2\pi t \sin 2\pi x + \frac{1}{9} \sin \frac{2\pi}{5} \cos 3\pi t \sin 3\pi x - \frac{1}{16} \sin \frac{\pi}{5} \cos 4\pi t \sin 4\pi x + - \dots \right)$

12.  $u = \sum_{n=1}^{\infty} B_n^* \sin nt \sin nx, \quad B_n^* = \frac{0.04}{\pi n^3} \sin \frac{n\pi}{2}$

14. **Team Project.** (c) From the given initial conditions we obtain

$$G_n(0) = B_n = \frac{2}{L} \int_0^L f(x) \sin \frac{n\pi x}{L} dx,$$

$$\dot{G}_n(0) = \lambda_n B_n^* + \frac{2A\omega(1 - \cos \omega\pi)}{n\pi(\lambda_n^2 - \omega^2)} = 0.$$

(e)  $u(0, t) = 0, w(0, t) = 0, u(L, t) = h(t), w(L, t) = h(t)$ . The simplest  $w$  satisfying these conditions is  $w(x, t) = xh(t)/L$ . Then

$$v(x, 0) = f(x) - xh(0)/L = f_1(x)$$

$$v_t(x, 0) = g(x) - xh'(0)/L = g_1(x)$$

$$v_{tt} - c^2 v_{xx} = -xh''/L.$$

16.  $F_n = \sin(n\pi x/L), G_n = a_n \cos(cn^2\pi^2 t/L^2)$

18. For the string the frequency of the  $n$ th mode is proportional to  $n$ , whereas for the beam it is proportional to  $n^2$ .

20.  $F(0) = A + C = 0, C = -A, F'(0) = \beta(B + D) = 0, D = -B$ . Then

$$F(x) = A(\cos \beta x - \cosh \beta x) + B(\sin \beta x - \sinh \beta x)$$

$$F''(L) = \beta^2[-A(\cos \beta L + \cosh \beta L) - B(\sin \beta L + \sinh \beta L)] = 0$$

$$F'''(L) = \beta^3[A(\sin \beta L - \sinh \beta L) - B(\cos \beta L + \cosh \beta L)] = 0.$$

The determinant  $(\cos \beta L + \cosh \beta L)^2 + \sin^2 \beta L - \sinh^2 \beta L$  of this system in the unknowns  $A$  and  $B$  must be zero, and from this the result follows.

From (23) we have

$$\cos \beta L = \frac{-1}{\cosh \beta L} \approx 0$$



because  $\cosh \beta L$  is very large. This gives the approximate solutions

$$\beta L \approx \frac{1}{2}\pi, \frac{3}{2}\pi, \frac{5}{2}\pi, \dots \text{ (more exactly, 1.875, 4.694, 7.855, } \dots \text{)}.$$

### SECTION 12.4. D'Alembert's Solution of the Wave Equation. Characteristics, page 548

**Purpose.** To show a simpler method of solving the wave equation, which, unfortunately, is not so universal as separation of variables.

#### Comment on Order of Sections

Section 12.11 on the solution of the wave equation by the Laplace transform may be studied directly after this section. We have placed that material at the end of this chapter because some students may not have studied Chap. 6 on the Laplace transform, which is not a prerequisite for Chap. 12.

#### Comment on Footnote 1

D'Alembert's *Traité de dynamique* appeared in 1743 and his solution of the vibrating string problem in 1747; the latter makes him, together with Daniel Bernoulli (1700–1782), the founder of the theory of PDEs. In 1754 d'Alembert became Secretary of the French Academy of Science and as such the most influential man of science in France.

### SOLUTIONS TO PROBLEM SET 12.4, page 552

2.  $u(0, t) = \frac{1}{2}[f(ct) + f(-ct)] = 0$ ,  $f(-ct) = -f(ct)$ , so that  $f$  is odd. Also

$$u(L, t) = \frac{1}{2}[f(ct + L) + f(-ct + L)] = 0$$

hence

$$f(ct + L) = -f(-ct + L) = f(ct - L).$$

This proves the periodicity.

4.  $(1/2\pi)(n\pi/2) \cdot 80.83 = 20.21n$

10. The Tricomi equation is elliptic in the upper half-plane and hyperbolic in the lower, because of the coefficient  $y$ .

$u = F(x)G(y)$  gives

$$yF''G = -FG'', \quad \frac{F''}{F} = -\frac{G''}{yG} = -k$$

and  $k = 1$  gives Airy's equation.

12. Parabolic. Characteristic equation

$$y'^2 + 2y' + 1 = (y' + 1)^2 = 0.$$

New variables  $v = \Phi = x$ ,  $w = \Psi = x + y$ . By the chain rule,

$$u_x = u_v + u_w$$

$$u_{xx} = u_{vv} + 2u_{vw} + u_{ww}$$

$$u_{xy} = u_{vw} + u_{ww}$$

$$u_{yy} = u_{ww}.$$

Substitution of this into the PDE gives the expected normal form

$$u_{vv} = 0.$$

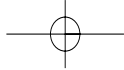

By integration,

$$u_v = \tilde{c}(w), \quad u = \tilde{c}(w)v + c(w).$$

In the original variables this becomes

$$u = xf_1(x+y) + f_2(x+y).$$

**14. Hyperbolic. Characteristic equation**

$$y'^2 - y' - 2 = (y' + 1)(y' - 2) = 0.$$

Hence new variables are  $v = y + x$ ,  $w = y - 2x$ . Solution:

$$u = f_1(x+y) + f_2(2x-y).$$

**16. Hyperbolic. New variables  $x = v$  and  $xy = w$ . The latter is obtained from**

$$-xy' - y = 0, \quad \frac{y'}{y} = -\frac{1}{x}, \quad \ln|y| = -\ln|x| + c.$$

By the chain rule we obtain in these new variables from the given PDE by cancellation of  $-yu_{yy}$  against a term in  $xu_{xy}$  and division of the remaining PDE by  $x$  the PDE

$$u_w + xu_{vw} = 0.$$

(The normal form is  $u_{vw} = -u_w/x = -u_w/v$ .) We set  $u_w = z$  and obtain

$$z_v = -\frac{1}{v}z, \quad z = \frac{c(w)}{v}.$$

By integration with respect to  $w$  we obtain the solution

$$u = \frac{1}{v}f_1(w) + f_2(v) = \frac{1}{x}f_1(xy) + f_2(x).$$

**18. Elliptic. The characteristic equation is**

$$y'^2 - 2y' + 5 = [y' - (1 - 2i)][y' - (1 + 2i)] = 0.$$

Complex solutions are

$$\Phi = y - (1 - 2i)x = \text{const}, \quad \Psi = y - (1 + 2i)x = \text{const}.$$

This gives the solutions of the PDE:

$$u = f_1(y - (1 - 2i)x) + f_2(y - (1 + 2i)x).$$

Since the PDE is linear and homogeneous, real solutions are the real and the imaginary parts of  $u$ .

**20. Hyperbolic. Characteristic equation**

$$y'^2 + 4y' + 3 = (y' + 1)(y' + 3) = 0.$$

The solution of the given PDE is

$$u = f_1(x+y) + f_2(3x+y).$$



**SECTION 12.5. Heat Equation: Solution by Fourier Series, page 552**

**Purpose.** This section has two purposes:

1. To solve a typical heat problem by steps similar to those for the wave equation, pointing to the two main differences: only *one* initial condition (instead of two) and  $u_t$  (instead of  $u_{tt}$ ), resulting in exponential functions in  $t$  (instead of cosine and sine in the wave equation).
2. Solution of Laplace's equation (which can be interpreted as a time-independent heat equation in two dimensions).

**Comments on Content**

Additional points to emphasize are

- More rapid decay with increasing  $n$ ,
- Difference in time evolution in Figs. 292 and 288,
- Zero can be an eigenvalue (see Example 4),
- Three standard types of boundary value problems,
- Analogy of electrostatic and (steady-state) heat problems.

Problem Set 12.5 includes additional heat problems and types of boundary conditions.

**SOLUTIONS TO PROBLEM SET 12.5, page 560**

2.  $u_1 = \sin x e^{-t}$ ,  $u_2 = \sin 2x e^{-4t}$ ,  $u_3 = \sin 3x e^{-9t}$ . A main difference is the rapidity of decay, so that series solutions (9) will be well approximated by partial sums of few terms.
4.  $(c^2 \pi^2 / L^2)10 = \ln 2$ ,  $c^2 = 0.00702L^2$
6.  $u = \sin 0.1 \pi x e^{-1.752 \pi^2 t / 100} + \frac{1}{2} \sin 0.2 \pi x e^{-1.752 \cdot 4 \pi^2 t / 100}$
8.  $u = \frac{8}{\pi^2} \left( \sin 0.1 \pi x e^{-0.01752 \pi^2 t} - \frac{1}{9} \sin 0.3 \pi x e^{-0.01752 (3\pi)^2 t} \right. \\ \left. + \frac{1}{25} \sin 0.5 \pi x e^{-0.01752 (5\pi)^2 t} - + \dots \right)$
10.  $u_I = U_1 + (U_2 - U_1)x/L$ ; this is the solution of (1) with  $\partial u / \partial t = 0$  satisfying the boundary conditions.
12.  $u(x, 0) = f(x) = 100$ ,  $U_1 = 100$ ,  $U_2 = 0$ ,  $u_I = 100 - 10x$ . Hence

$$\begin{aligned} B_n &= \frac{2}{10} \int_0^{10} [100 - (100 - 10x)] \sin \frac{n\pi x}{10} dx \\ &= \frac{2}{10} \int_0^{10} 10x \sin \frac{n\pi x}{10} dx \\ &= -\frac{200}{n\pi} \cos n\pi \\ &= \frac{(-1)^{n+1}}{n} \cdot 63.66. \end{aligned}$$

This gives the solution

$$u(x, t) = 100 - 10x + 63.66 \sum_{n=1}^{\infty} \frac{(-1)^{n+1}}{n} \sin \frac{n\pi x}{10} e^{-1.752(n\pi/10)^2 t}.$$

For  $x = 5$  this becomes

$$u(5, t) = 50 + 63.66[e^{-0.1729t} - \frac{1}{3}e^{-1.556t} + \frac{1}{5}e^{-4.323t} - \dots].$$

Obviously, the sum of the first few terms is a good approximation of the true value at any  $t > 0$ . We find:

$$\frac{t \quad 1 \quad 2 \quad 3 \quad 10 \quad 50}{u(5, t) \quad 99 \quad 94 \quad 88 \quad 61 \quad 50}.$$

$$14. u = \frac{\pi}{2} - \frac{4}{\pi} \left( \cos x e^{-t} + \frac{1}{9} \cos 3x e^{-9t} + \frac{1}{25} \cos 5x e^{-25t} + \dots \right)$$

$$16. u = 0.5 \cos 4x e^{-16t}$$

$$18. u = \frac{\pi}{4} - \frac{2}{\pi} \left( \cos 2x e^{-4t} + \frac{1}{9} \cos 6x e^{-36t} + \frac{1}{25} \cos 10x e^{-100t} + \dots \right)$$

20.  $F = A \cos px + B \sin px$ ,  $F(0) = A = 0$ ,  $F'(L) = Bp \cos pL = 0$ ,  $pL = (2n - 1)\pi/2$ ; hence

$$u = \sum_{n=1}^{\infty} B_{2n-1} \sin \frac{(2n-1)\pi x}{2L} \exp \left\{ - \left[ \frac{(2n-1)\pi c}{2L} \right]^2 t \right\}$$

where

$$B_{2n-1} = \frac{2}{L} \int_0^L U_0 \sin \frac{(2n-1)\pi x}{2L} dx = \frac{4U_0}{\pi(2n-1)}.$$

$$22. u = \frac{4U_0}{\pi} \sum_{n=1}^{\infty} \frac{1}{n} \sin^2 \frac{n\pi}{4} \sin nx e^{-c^2 n^2 t}$$

$$= \frac{4U_0}{\pi} \left( \frac{1}{2} \sin x e^{-c^2 t} + \frac{1}{2} \sin 2x e^{-4c^2 t} + \dots \right)$$

24.  $c^2 v_{xx} = v_t$ ,  $v(0, t) = 0$ ,  $v(\pi, t) = 0$ ,  $v(x, 0) = f(x) + Hx(x - \pi)/(2c^2)$ , so that, as in (9) and (10),

$$u(x, t) = - \frac{Hx(x - \pi)}{2c^2} + \sum_{n=1}^{\infty} B_n \sin nx e^{-c^2 n^2 t}$$

where

$$B_n = \frac{2}{\pi} \int_0^{\pi} \left( f(x) + \frac{Hx(x - \pi)}{2c^2} \right) \sin nx dx.$$

26.  $v(x, t) = u(x, t)w(t)$ . Substitution into the given PDE gives

$$u_t w + u w' = c^2 u_{xx} w - u w.$$

Division by  $w$  gives

$$u_t + u w'/w = c^2 u_{xx} - u.$$

This reduces to  $u_t = c^2 u_{xx}$  if  $w'/w = -1$ , hence  $w = e^{-t}$ . Also,  $u(0, t) = 0$ ,  $u(L, t) = 0$ ,  $u(x, 0) = f(x)$ , so that the solution is  $v = e^{-t}u$  with  $u$  given by (9) and (10).

$$28. u = \frac{880}{\pi} \sum_{n=1}^{\infty} \frac{1}{(2n+1) \sinh(2n+1)\pi} \sin \frac{(2n+1)\pi x}{20} \sinh \frac{(2n+1)\pi y}{20}$$

30. CAS Project. (a)  $u = (\sin \pi x \sinh \pi y) / \sinh 2\pi$

$$(b) \quad u_y(x, 0, t) = 0, \quad u_y(x, 2, t) = 0, \quad u = \sin m\pi x \cos n\pi y$$

32.  $u = u_{\text{I}} + u_{\text{II}}$ , where

$$u_{\text{I}} = \frac{4U_1}{\pi} \sum_{n=1}^{\infty} \frac{1}{2n-1} \sin \frac{(2n-1)\pi x}{24} \frac{\sinh [(2n-1)\pi y/24]}{\sinh (2n-1)\pi}$$

$$u_{\text{II}} = \frac{4U_0}{\pi} \sum_{n=1}^{\infty} \frac{1}{2n-1} \sin \frac{(2n-1)\pi x}{24} \frac{\sinh [(2n-1)\pi(1-y/24)]}{\sinh (2n-1)\pi}.$$

34.  $u = F(x)G(y)$ ,  $F = A \cos px + B \sin px$ ,  $u_x(0, y) = F'(0)G(y) = 0$ ,  $B = 0$ ,  
 $G = C \cosh py + D \sinh py$ ,  $u_y(x, b) = F(x)G'(b) = 0$ ,  $C = \cosh pb$ ,  
 $D = -\sinh pb$ ,  $G = \cosh(pb - py)$ . For  $u = \cos px \cosh p(b - y)$  we get

$$u_x(a, y) + hu(a, y) = (-p \sin pa + h \cosh pa) \cosh p(b - y) = 0.$$

Hence  $p$  must satisfy  $\tan ap = h/p$ , which has infinitely many positive real solutions  $p = \gamma_1, \gamma_2, \dots$ , as you can illustrate by a simple sketch. *Answer:*

$$u_n = \cos \gamma_n x \cosh \gamma_n(b - y),$$

where  $\gamma = \gamma_n$  satisfies  $\gamma \tan \gamma a = h$ .

To determine coefficients of series of  $u_n$ 's from a boundary condition at the lower side is difficult because that would not be a Fourier series, the  $\gamma_n$ 's being only approximately regularly spaced. See [C3], pp. 114–119, 167.

## SECTION 12.6. Heat Equation: Solution by Fourier Integrals and Transforms, page 562

**Purpose.** Whereas we solved the problem of a finite bar in the last section by using Fourier series, we show that for an infinite bar (practically, a long insulated wire) we can use the Fourier integral for the same purpose. Figure 296 shows the time evolution for a “rectangular” initial temperature ( $100^\circ\text{C}$  between  $x = -1$  and  $+1$ , zero elsewhere), giving bell-shaped curves as for the density of the normal distribution.

We also show typical applications of the Fourier transform and the Fourier sine transform to the heat equation.

**Short Courses.** This section can be omitted.

## SOLUTIONS TO PROBLEM SET 12.6, page 568

$$2. A = \frac{2k}{\pi(p^2 + k^2)}, B = 0, \quad u = \frac{2k}{\pi} \int_0^\infty \frac{\cos px}{p^2 + k^2} e^{-c^2 p^2 t} dp$$

$$4. A = \frac{2}{\pi} \int_0^\infty \frac{\sin v}{v} \cos pv \, dv = \frac{2}{\pi} \cdot \frac{\pi}{2} = 1 \text{ if } 0 < p < 1 \text{ and } 0 \text{ if } p > 1. \text{ Hence}$$

$$u = \int_0^1 \cos px \, e^{-c^2 p^2 t} dp.$$

$$6. A = 0, B = \frac{1}{\pi} \int_{-1}^1 v \sin pv \, dv = \frac{2}{\pi} \frac{\sin p - p \cos p}{p^2}; \text{ hence}$$

$$u = \frac{2}{\pi} \int_0^\infty \frac{\sin p - p \cos p}{p^2} \sin px e^{-c^2 p^2 t} dp.$$

$$8. \text{ By integration, } \int_0^\pi \cos px \, dp = \frac{\sin \pi x}{x}.$$

10. **CAS Project.** (a) Set  $w = -v$  in (21) to get  $\operatorname{erf}(-x) = -\operatorname{erf} x$ .

(b) See (36) in App. 3.1.

(e) In (12) the argument  $x + 2cz\sqrt{t}$  is 0 (the point where  $f$  jumps) when  $z = -x/(2c\sqrt{t})$ . This gives the lower limit of integration.

$$(f) u(x, t) = \frac{U_0}{2} \left[ \operatorname{erf} \frac{1-x}{2c\sqrt{t}} + \operatorname{erf} \frac{1+x}{2c\sqrt{t}} \right], \text{ where } t > 0.$$

(g) Set  $w = s/\sqrt{2}$  in (21).

### SECTION 12.7. Modeling: Membrane, Two-Dimensional Wave Equation, page 569

**Purpose.** A careful derivation of the two-dimensional wave equation governing the motions of a drumhead, from physical assumptions (the analog of the modeling in Sec. 12.2).

### SECTION 12.8. Rectangular Membrane. Double Fourier Series, page 571

**Purpose.** To solve the two-dimensional wave equation in a rectangle  $0 \leq x \leq a$ ,  $0 \leq y \leq b$  ("rectangular membrane") by separation of variables and double Fourier series.

#### Comment on Content

New features as compared with the one-dimensional case (Sec. 12.3) are as follows:

1. We have to separate twice, first by  $u = F(x, y)G(t)$ , then the Helmholtz equation for  $F$  by  $F = H(x)Q(y)$ .
2. We get a double sequence of infinitely many eigenvalues  $\lambda_{mn}$  and eigenfunctions  $u_{mn}$ ; see (9), (10).
3. We need double Fourier series (easily obtainable from the usual Fourier series) to get a solution that also satisfies the initial conditions.

### SOLUTIONS TO PROBLEM SET 12.8, page 578

4.  $B_{mn} = (-1)^{m+1}8/(mn\pi^2)$  if  $n$  odd,  $B_{mn} = 0$  if  $n$  even. Thus

$$f(x, y) = \frac{8}{\pi^2} \left( \sin \pi x \sin \pi y + \frac{1}{3} \sin \pi x \sin 3\pi y \right. \\ \left. - \frac{1}{2} \sin 2\pi x \sin \pi y - \frac{1}{6} \sin 2\pi x \sin 3\pi y \right. \\ \left. + \frac{1}{3} \sin 3\pi x \sin \pi y + \frac{1}{9} \sin 3\pi x \sin 3\pi y + \cdots \right).$$

6.  $B_{mn} = (-1)^{m+n}K_{mn}/(mn\pi^2)$ , where

$$K_{mn} = \begin{cases} 0 & \text{if } m, n \text{ even} \\ 16 & \text{if } m, n \text{ odd} \\ 8 & \text{otherwise} \end{cases}$$

8.  $B_{mn} = 64/(m^3n^3\pi^6)$  if  $m, n$  odd, 0 otherwise

10. The program will give you

$$\begin{aligned} 85 &= 5 \cdot 17 = 2^2 + 9^2 = 6^2 + 7^2 \\ 145 &= 5 \cdot 29 = 1^2 + 12^2 = 8^2 + 9^2 \\ 185 &= 5 \cdot 37 = 4^2 + 13^2 = 8^2 + 11^2 \\ 221 &= 13 \cdot 17 = 5^2 + 14^2 = 10^2 + 11^2 \\ 377 &= 13 \cdot 29 = 4^2 + 19^2 = 11^2 + 16^2 \\ 493 &= 17 \cdot 29 = 3^2 + 22^2 = 13^2 + 18^2 \end{aligned}$$

etc.

12.  $0.1 \sin \sqrt{2}t \sin x \sin y$

18.  $A = ab$ ,  $b = A/a$ , so that from (9) with  $m = n = 1$  by differentiating with respect to  $a$  and equating the derivative to zero, we obtain

$$\left( \frac{\lambda_{11}^2}{c^2\pi^2} \right)' = \left( \frac{1}{a^2} + \frac{1}{b^2} \right)' = \left( \frac{1}{a^2} + \frac{a^2}{A^2} \right)' = \frac{-2}{a^3} + \frac{2a}{A^2} = 0;$$

hence  $a^4 = A^2$ ,  $a^2 = A$ ,  $b = A/a = a$ .

20.  $B_{mn} = (-1)^{m+n}ab/(mn\pi^2)$

22.  $B_{mn} = 0$  ( $m$  or  $n$  even),  $B_{mn} = \frac{64a^2b^2}{\pi^6m^3n^3}$  ( $m, n$  odd)

$$24. \frac{64a^2b^2}{\pi^6} \sum_{\substack{m=1 \\ m, n \text{ odd}}}^{\infty} \sum_{\substack{n=1 \\ n, n \text{ odd}}}^{\infty} \frac{1}{m^3n^3} \cos \left( \pi t \sqrt{\frac{m^2}{a^2} + \frac{n^2}{b^2}} \right) \sin \frac{m\pi x}{a} \sin \frac{n\pi y}{b}$$

### SECTION 12.9. Laplacian in Polar Coordinates. Circular Membrane Fourier–Bessel Series, page 579

**Purpose.** Detailed derivation of the transformation of the Laplacian into polar coordinates. Derivation of the function that models vibrations of a circular membrane.

#### Comment on Content

The transformation is a typical case of a task often required in applications. It is done by two applications of the chain rule.

In solving the wave equation we concentrate on the simpler case of radially symmetric vibrations, that is, vibrations independent of the angle. (For eigenfunctions depending on the angle, see Probs. 27–30.) We do three steps:

1.  $u = W(r)G(t)$  gives for  $W$  Bessel's equation with  $\nu = 0$ , hence solutions  $W(r) = J_0(kr)$ .
2. We satisfy the boundary condition  $W(R) = 0$  by choosing suitable values of  $k$ .
3. A Fourier–Bessel series (18) helps to get the solution (17) of the entire problem.

**Short Courses.** This section can be omitted.

## SOLUTIONS TO PROBLEMS SET 12.9, page 585

6. **Team Project.** (a)  $r^2 \cos 2\theta = r^2(\cos^2 \theta - \sin^2 \theta) = x^2 - y^2$ ,  $r^2 \sin 2\theta = 2xy$ , etc.

$$(c) u = \frac{400}{\pi} \left( r \sin \theta + \frac{1}{3} r^3 \sin 3\theta + \frac{1}{5} r^5 \sin 5\theta + \cdots \right)$$

(d) The form of the series results as in (b), and the formulas for the coefficients follow from

$$u_r(R, \theta) = \sum_{n=1}^{\infty} nR^{n-1}(A_n \cos n\theta + B_n \sin n\theta) = f(\theta).$$

(f)  $u = -(r + 9/r)(\sin \theta)/8$  by separating variables

8.  $600 r \sin \theta - 200r^3 \sin 3\theta$

$$10. \frac{2}{\pi} r \sin \theta + \frac{1}{2} r^2 \sin 2\theta - \frac{2}{9\pi} r^3 \sin 3\theta - \frac{1}{4} r^4 \sin 4\theta + \cdots$$

Except for the presence of the variable  $r$ , this is just another important application of Fourier series, and we concentrate on a few simple practically important types of boundary values. Of course, earlier problems on Fourier series can now be modified by introducing the powers of  $r$  and considered from the present point of view.

$$12. \frac{\pi^2}{3} - 4 \left( r \cos \theta - \frac{1}{4} r^2 \cos 2\theta + \frac{1}{9} r^3 \cos 3\theta - \frac{1}{16} r^4 \cos 4\theta + \cdots \right)$$

14. To get  $u = 0$  on the  $x$ -axis, the idea is to extend the given potential from  $0 < \theta < \pi$  skew-symmetrically to the whole boundary circle  $r = 1$ ; that is,

$$u(1, \theta) = \begin{cases} 110\theta(\pi - \theta) & \text{if } 0 < \theta < \pi \text{ (given)} \\ 110\theta(\pi + \theta) & \text{if } -\pi < \theta < 0. \end{cases}$$

Then you obtain (valid in the whole disk and thus in the semidisk)

$$u(r, \theta) = \frac{880}{\pi} \left( r \sin \theta + \frac{1}{3^3} r^3 \sin 3\theta + \frac{1}{5^3} r^5 \sin 5\theta + \cdots \right).$$

16.  $\nabla^2 u = u_{x^*x^*} + u_{y^*y^*}$  follows by the chain rule with simplifications similar to those in the text in the derivation of  $\nabla^2 u$  in polar coordinates.

18.  $\lambda_m/2\pi = c\alpha_m/(2\pi R)$  increases with decreasing  $R$ .

20. **CAS Project.** (b) Error 0.04864 ( $m = 1$ ), 0.02229, 0.01435, 0.01056, 0.00835, 0.00691, 0.00589, 0.00513, 0.00454, 0.00408 ( $m = 10$ )

(c) The approximation of the partial sums is poorest for  $r = 0$ .

(d) The radii of the nodal circles are

$$u_2: \alpha_1/\alpha_2 = 0.43565 \quad \text{Comparison } 0.435/0.500 = 0.87$$

$$u_3: \alpha_1/\alpha_3 = 0.27789 \quad 0.278/0.333 = 0.83$$

$$\alpha_2/\alpha_3 = 0.63788 \quad 0.638/0.667 = 0.96$$

$$u_4: \alpha_1/\alpha_4 = 0.2039 \quad 0.204/0.250 = 0.82$$

$$\alpha_2/\alpha_4 = 0.4681 \quad 0.468/0.500 = 0.94$$

$$\alpha_3/\alpha_4 = 0.7339 \quad 0.734/0.750 = 0.98.$$



We see that the larger radii are better approximations of the values of the nodes of the string than the smaller ones. The smallest quotient does not seem to improve (to get closer to 1); on the contrary, e.g., for  $u_6$  it is 0.80. The other ratios seem to approach 1 and so does the sum of all of them divided by  $m - 1$ .

22. The reason is that  $f(0) = 1$ . The partial sums equal

$$1.10801 \quad 0.96823 \quad 1.01371 \quad 0.99272 \quad 1.00436 \quad \dots$$

the last value having 3-digit accuracy. Musically the values indicate substantial contributions of overtones to the overall sound.

30.  $\alpha_{11}/2\pi = 0.6098$  (see Table A1 in App. 5)

### SECTION 12.10. Laplace's Equation in Cylindrical and Spherical Coordinates. Potential, page 587

**Purpose. 1.** Transformation of the Laplacian into cylindrical coordinates (which is trivial because of Sec. 12.9) and spherical coordinates; some remarks on areas in which Laplace's equation is basic.

**2.** Separation of the Laplace equation in spherical coordinates and application to a typical boundary value problem. For simplicity we consider a boundary value problem for a sphere with boundary values depending only on  $\phi$ . We do three steps:

1.  $u = G(r)H(\phi)$  and separation gives for  $H$  Legendre's equation.
2. Continuity requirements restrict  $H$  to Legendre polynomials.
3. A Fourier-Legendre series (18) helps to get the solution (17) of the interior problem. Similarly for the exterior problem, whose solution is (20).

**Short Courses.** Omit the derivation of the Laplacian in cylindrical and spherical coordinates.

### SOLUTIONS TO PROBLEM SET 12.10, page 593

2. By (11') in Sec. 5.3 we have

$$u_1 = A_1 r \cos \phi = 0 \quad \text{if} \quad \phi = \frac{1}{2}\pi.$$

This is the  $xy$ -plane. Similarly,

$$u_2 = A_2 \frac{r^2}{2} (3 \cos^2 \phi - 1) = 0 \quad \text{if} \quad \cos \phi = \frac{1}{\sqrt{3}}$$

and

$$u_3 = A_3 \frac{r^3}{2} (5 \cos^3 \phi - 3 \cos \phi) = 0 \quad \text{if} \quad \cos \phi = 0 \quad \text{and} \quad \sqrt{\frac{3}{5}}.$$

6. Substituting  $u = u(r)$  into (7) gives

$$\nabla^2 u = u'' + \frac{2}{r} u' = 0, \quad \frac{u''}{u'} = -\frac{2}{r}, \quad \ln |u'| = -2 \ln |r| + c_1$$

so that  $u' = \tilde{c}/r^2$  and  $u = c/r + k$ .

8.  $u = 3000/r - 40$
10.  $u = 758.3 - 216.4 \ln r$ . The curve in Prob. 8 lies below the present one. This is physically plausible.

14.  $\tilde{f}(w) = w$ ,  $A_n = \frac{2n+1}{2} \int_{-1}^1 w P_n(w) dw$ . Since  $w = P_1(w)$  and the  $P_n(w)$  are orthogonal on the interval  $-1 \leq w \leq 1$ , we obtain  $A_1 = 1$ ,  $A_n = 0$  ( $n = 0, 2, 3, \dots$ ). Answer:  $u = r \cos \phi$ . Of course, this is at once seen by integration.

16.  $A_n = \frac{2n+1}{2} \int_0^\pi (\sin^2 \phi) P_n(\cos \phi) \sin \phi d\phi$ ,  $\{A_n\} = \{\frac{2}{3}, 0, -\frac{2}{3}, 0, \dots\}$ . Hence the potential in the interior of  $S$  is

$$u = \frac{1}{2} - \frac{1}{2} \left( \frac{4}{3} r^2 P_2(\cos \phi) - \frac{1}{3} \right) = \frac{2}{3} - \frac{2}{3} r^2 P_2(\cos \phi).$$

20.  $\frac{4}{3r^3} P_2(\cos \phi) - \frac{1}{3r}$ ,  $\frac{8}{5r^4} P_3(\cos \phi) - \frac{3}{5r^2} P_1(\cos \phi)$

22. Set  $\frac{1}{r} = \rho$  and consider  $u(\rho, \theta, \phi) = rv(r, \theta, \phi)$ . By differentiation,

$$u_\rho = (v + rv_r) \left( -\frac{1}{\rho^2} \right), \quad u_{\rho\rho} = (2v_r + rv_{rr}) \frac{1}{\rho^4} + \frac{2}{\rho^3} (v + rv_r).$$

Thus

$$u_{\rho\rho} + \frac{2}{\rho} u_\rho = \frac{1}{\rho^4} (2v_r + rv_{rr}) = r^5 \left( v_{rr} + \frac{2}{r} v_r \right).$$

By substituting this and  $u_{\phi\phi} = rv_{\phi\phi}$ , etc., into (7) [written in terms of  $\rho$ ] and dividing by  $r^5$  we obtain the result.

24. **Team Project** (a) The two drops over a portion of the cable of length  $\Delta x$  are  $-Ri\Delta x$  and  $-L(\partial i/\partial t)\Delta x$ , respectively. Their sum equals the difference  $u_{x+\Delta x} - u_x$ . Divide by  $\Delta x$  and let  $\Delta x \rightarrow 0$ .

(c) To get the first PDE, differentiate the first transmission line equation with respect to  $x$  and use the second equation to replace  $i_x$  and  $i_{xt}$ :

$$\begin{aligned} -u_{xx} &= Ri_x + Li_{xt} \\ &= R(-Gu - Cu_t) + L(-Gu_t - Cu_{tt}). \end{aligned}$$

Now collect terms. Similarly for the second PDE.

- (d) Set  $\frac{1}{RC} = c^2$ . Then  $u_t = c^2 u_{xx}$ , the heat equation. By (9), (10), Sec. 12.5,

$$u = \frac{4U_0}{\pi} \left( \sin \frac{\pi x}{l} e^{-\lambda_1^2 t} + \frac{1}{3} \sin \frac{3\pi x}{l} e^{-\lambda_3^2 t} + \dots \right), \quad \lambda_n^2 = \frac{n^2 \pi^2}{l^2 RC}.$$

- (e)  $u = U_0 \cos(\pi t / (l\sqrt{LC})) \sin(\pi x / l)$

### SECTION 12.11. Solutions of PDEs by Laplace Transforms, page 594

**Purpose.** For students familiar with Chap. 6 we show that the Laplace transform also applies to certain PDEs. In such an application the subsidiary equation will generally be an ODE.

**Short Courses.** This section can be omitted.

**SOLUTIONS TO PROBLEM SET 12.11, page 596**

4.  $w = w(x, t)$ ,  $W = \mathcal{L}\{w(x, t)\} = W(x, s)$ . The subsidiary equation is

$$\frac{\partial W}{\partial x} + x\mathcal{L}\{w_t(x, t)\} = \frac{\partial W}{\partial x} + x(sW - w(x, 0)) = x\mathcal{L}(1) = \frac{x}{s} \text{ and } w(x, 0) = 1.$$

By simplification,

$$\frac{\partial W}{\partial x} + xsW = x + \frac{x}{s}.$$

By integration of this first-order ODE with respect to  $x$  we obtain

$$W = c(s)e^{-sx^2/2} + \frac{1}{s^2} + \frac{1}{s}.$$

For  $x = 0$  we have  $w(0, t) = 1$  and

$$W(0, s) = \mathcal{L}\{w(0, t)\} = \mathcal{L}\{1\} = \frac{1}{s} = c(s) + \frac{1}{s^2} + \frac{1}{s}.$$

Hence  $c(s) = -1/s^2$ , so that

$$W = -\frac{1}{s^2} e^{-sx^2/2} + \frac{1}{s^2} + \frac{1}{s}.$$

The inverse Laplace transform of this solution of the subsidiary equation is

$$w(x, t) = -(t - \frac{1}{2}x^2) u(t - \frac{1}{2}x^2) + t + 1 = \begin{cases} t + 1 & \text{if } t < \frac{1}{2}x^2 \\ \frac{1}{2}x^2 + 1 & \text{if } t > \frac{1}{2}x^2. \end{cases}$$

6.  $W = \mathcal{L}\{w\}$ ,  $W_{xx} = (100s^2 + 100s + 25)W = (10s + 5)^2W$ . The solution of this ODE is

$$W = c_1(s)e^{-(10s+5)x} + c_2(s)e^{(10s+5)x}$$

with  $c_2(s) = 0$ , so that the solution is bounded.  $c_1(s)$  follows from

$$W(0, s) = \mathcal{L}\{w(0, t)\} = \mathcal{L}\{\sin t\} = \frac{1}{s^2 + 1} = c_1(s).$$

Hence

$$W = \frac{1}{s^2 + 1} e^{-(10s+5)x}.$$

The inverse Laplace transform (the solution of our problem) is

$$w = \mathcal{L}^{-1}\{W\} = e^{-5x}u(t - 10x) \sin(t - 10x),$$

a traveling wave decaying with  $x$ . Here  $u$  is the unit step function (the Heaviside function).

8. From  $W = F(s)e^{-(x/c)\sqrt{s}}$  and the convolution theorem we have

$$w = f * \mathcal{L}^{-1}\{e^{-k\sqrt{s}}\}, \quad k = \frac{x}{c}.$$

From this and formula 39 in Sec. 6.9 we get, as asserted,

$$w = \int_0^t f(t - \tau) \frac{k}{2\sqrt{\pi\tau^3}} e^{-k^2/(4\tau)} d\tau.$$

10.  $W_0(x, s) = s^{-1}e^{-\sqrt{s}x/c}$ ,  $\mathcal{L}\{u(t)\} = 1/s$ , and since  $w(x, 0) = 0$ ,

$$\begin{aligned} W(x, s) &= F(s)sW_0(x, s) \\ &= F(s)[sW_0(x, s) - w(x, 0)] \\ &= F(s) \mathcal{L} \left\{ \frac{\partial w_0}{\partial t} \right\}. \end{aligned}$$

Now apply the convolution theorem.

### SOLUTIONS TO CHAP. 12 REVIEW QUESTIONS AND PROBLEMS, page 597

16.  $k = -6$ ,  $m = \pm 1$

18.  $u = A(x) \cos 4y + B(x) \sin 4y$

20.  $u_y = v$ ,  $v_x + v + x + y + 1 = 0$ ,  $v = c(y)e^{-x} - x - y$ . By integration,

$$u = \int v dy = c_1(y)e^{-x} - xy - \frac{1}{2}y^2 + c_2(x).$$

22. Depending on the sign of the separation constant, we obtain

$$u = (Ae^{kx} + Be^{-kx})(C \cos ky + D \sin ky)$$

$$u = (ax + b)(cy + d)$$

$$u = (A \cos kx + B \sin kx)(Ce^{ky} + De^{-ky}).$$

$$24. u = \frac{4}{\pi} \left( \cos t \sin x - \frac{1}{9} \cos 3t \sin 3x + \frac{1}{25} \cos 5t \sin 5x - + \dots \right)$$

$$26. u = \frac{8}{\pi} \left( \cos t \sin x + \frac{1}{3^3} \cos 3t \sin 3x + \frac{1}{5^3} \cos 5t \sin 5x + \dots \right)$$

$$28. u = \frac{20000}{\pi^3} \left( \sin \frac{\pi x}{50} e^{-0.004572t} + \frac{1}{27} \sin \frac{3\pi x}{50} e^{-0.04115t} + \frac{1}{125} \sin \frac{5\pi x}{50} e^{-0.1143t} + \dots \right)$$

$$30. u = 3 \sin \frac{\pi x}{10} e^{-0.1143t} - \sin \frac{3\pi x}{10} e^{-1.029t}$$

$$32. u = \pi^2 - 12 \left[ (\cos x)e^{-t} - \frac{1}{4}(\cos 2x)e^{-4t} + \frac{1}{9}(\cos 3x)e^{-9t} - + \dots \right]$$

$$36. u = \frac{64}{\pi^2} \sum_{\substack{m=1 \\ m, n \text{ odd}}}^{\infty} \sum_{n=1}^{\infty} \frac{1}{m^3 n^3} \sin mx \sin ny e^{-c^2(m^2+n^2)t}$$

38. Parabolic,  $y'^2 - 4y' = (y' - 2)^2 = 0$ ,  $v = x$ ,  $w = y - 2x$ ; hence

$$u = xf_1(y - 2x) + f_2(y - 2x).$$

40.  $u_{xx} + \frac{5}{2}u_{xy} + u_{yy} = 0$ , hyperbolic. The characteristic equation is

$$y'^2 - \frac{5}{2}y' + 1 = (y' - \frac{1}{2})(y' - 2) = 0.$$

Hence the solution is

$$u = f_1(y - \frac{1}{2}x) + f_2(y - 2x).$$

42.  $u_{xx} - \frac{1}{2}u_{xy} - \frac{1}{2}u_{yy} = 0$ , hyperbolic. The characteristic equation is

$$y'^2 + \frac{1}{2}y' - \frac{1}{2} = (y' - \frac{1}{2})(y' + 1) = 0.$$

Hence the solution is

$$u = f_1(y - \frac{1}{2}x) + f_2(y + x).$$

44.  $\lambda_{11}/2\pi = c\pi(\sqrt{1+1})/2\pi = 1/\sqrt{2}$

46. Area  $\pi R^2/2 = 1$ ,  $R = \sqrt{2/\pi}$ , and

$$ck_{11}/(2\pi) = k_{11}/(2\pi) = \alpha_{11}/(2\pi R) = 3.832/(2\pi\sqrt{2/\pi}) = 3.832/\sqrt{8\pi}.$$

48.  $u = \frac{(u_0 - u_1)r_0r_1}{(r_1 - r_0)r} + \frac{u_1r_1 - u_0r_0}{r_1 - r_0}$ , where  $r$  is the distance from the center of the spheres

50.  $f(\phi) = 4 \cos^3 \phi$ . Now, by (11'), Sec. 5.3,

$$\cos^3 \phi = \frac{2}{5}P_3(\cos \phi) + \frac{3}{5}P_1(\cos \phi).$$

Answer:

$$u = \frac{8}{5}r^3P_3(\cos \phi) + \frac{12}{5}rP_1(\cos \phi).$$

## Part D. COMPLEX ANALYSIS

### Major Changes

In the previous edition, conformal mapping was distributed over several sections in the first chapter on complex analysis. It has now been given greater emphasis by consolidation of that material in a separate chapter (Chap. 17), which can be used independently of a CAS (just as any other chapter) or in part supported by the graphic capabilities of a CAS. Thus in this respect one has complete freedom.

Recent teaching experience has shown that the present arrangement seems to be preferable over that of the 8th edition.

## CHAPTER 13 Complex Numbers and Functions

### SECTION 13.1. Complex Numbers. Complex Plane, page 602

**Purpose.** To discuss the algebraic operations for complex numbers and the representation of complex numbers as points in the plane.

#### Main Content, Important Concepts

Complex number, real part, imaginary part, imaginary unit

The four algebraic operations in complex

Complex plane, real axis, imaginary axis

Complex conjugates

#### Two Suggestions on Content

1. Of course, at the expense of a small conceptual concession, one can also start immediately from (4), (5),

$$z = x + iy, \quad i^2 = -1$$

and go on from there.

2. If students have some knowledge of complex numbers, the practical division rule (7) and perhaps (8) and (9) may be the only items to be recalled in this section. (But I personally would do more in any case.)

### SOLUTIONS TO PROBLEM SET 13.1, page 606

2. Note that  $z = 2 + 2i$  and  $iz = -2 + 2i$  lie on the bisecting lines of the first and second quadrants.

4.  $z_1 z_2 = 0$  if and only if

$$\operatorname{Re}(z_1 z_2) = x_2 x_1 - y_2 y_1 = 0 \quad \text{and} \quad \operatorname{Im}(z_1 z_2) = y_2 x_1 + x_2 y_1 = 0.$$

Let  $z_2 \neq 0$ , so that  $x_2^2 + y_2^2 \neq 0$ . Now  $x_2^2 + y_2^2$  is the coefficient determinant of our homogeneous system of equations in the “unknowns”  $x_1$  and  $y_1$ , so that this system has only the trivial solution; hence  $z_1 = 0$ .

8.  $23 - 2i$

10.  $-9, 16$

12.  $z_1/z_2 = -7/41 + (22/41)i$ ,  $\bar{z}_1/\bar{z}_2 = \overline{(z_1/z_2)} = -7/41 - (22/41)i$   
 14.  $-5/13 - (12/13)i$ ,  $-5/13 + (12/13)i$   
 16.  $3x^2y - y^3, y^3$   
 18.  $\text{Im}[(1+i)^8 z^2] = \text{Im}[(2i)^4 z^2] = \text{Im}[2^4 z^2] = 32xy$

### SECTION 13.2. Polar Form of Complex Numbers. Powers and Roots, page 607

**Purpose.** To give the student a firm grasp of the polar form, including the principal value  $\text{Arg } z$ , and its application in multiplication and division.

#### Main Content, Important Concepts

Absolute value  $|z|$ , argument  $\theta$ , principal value  $\text{Arg } \theta$

Triangle inequality (6)

Multiplication and division in polar form

$n$ th root,  $n$ th roots of unity (16)

### SOLUTIONS TO PROBLEM SET 13.2, page 611

2.  $2(\cos \frac{1}{2}\pi + i \sin \frac{1}{2}\pi)$ ,  $2(\cos(-\frac{1}{2}\pi) + i \sin(-\frac{1}{2}\pi))$   
 4.  $\sqrt{\frac{1}{4} + \frac{1}{16}\pi^2} (\cos \arctan \frac{1}{2}\pi + i \sin \arctan \frac{1}{2}\pi)$   
 6. Simplification shows that the quotient equals  $-3$ . Answer:  $3(\cos \pi + i \sin \pi)$ .  
 8. Division shows that the given quotient equals

$$\frac{22}{41} + \frac{7}{41}i.$$

Hence the polar form is

$$\frac{1}{41}\sqrt{22^2 + 7^2} (\cos \arctan \frac{7}{22} + i \sin \arctan \frac{7}{22}).$$

10. 3.09163,  $-3.09163$ . Of course, the problem should be a reminder that the principal value of the argument is discontinuous along the negative real axis, where it jumps by  $2\pi$ .  
 12.  $\pi$  since the given value is negative real.  
 14.  $(1+i)^{12} = (2i)^6 = 2^6 i^6 = 2^6 i^2 = -2^6$ . Hence the principal value of the argument is  $\pi$ .  
 Alternatively,  $\text{Arg}(1+i) = \frac{1}{4}\pi$ . Times 12 gives  $3\pi$ , so that the principal value of the argument is  $\pi$ , as before.  
 16.  $\pm i$   
 18.  $2 \pm 2\sqrt{3}i$   
 20.  $-12i$   
 22.  $\pm 1, \pm i, \pm(1 \pm i)/\sqrt{2}$   
 24. The three values are

$$\begin{aligned} & \sqrt[3]{5} (\cos \theta + i \sin \theta) \\ & \sqrt[3]{5} (\cos(\theta + \frac{2}{3}\pi) + i \sin(\theta + \frac{2}{3}\pi)) \\ & \sqrt[3]{5} (\cos(\theta + \frac{4}{3}\pi) + i \sin(\theta + \frac{4}{3}\pi)) \end{aligned}$$

where  $\theta = \frac{1}{3} \arctan \frac{4}{3}$ .

**26. Team Project. (a)** Use (15).

**(b)** Use (10) in App. 3.1 in the form

$$\cos \frac{1}{2}\theta = \sqrt{\frac{1}{2}(1 + \cos \theta)}, \quad \sin \frac{1}{2}\theta = \sqrt{\frac{1}{2}(1 - \cos \theta)},$$

multiply them by  $\sqrt{r}$ ,

$$\sqrt{r} \cos \frac{1}{2}\theta = \sqrt{\frac{1}{2}(r + r \cos \theta)}, \quad \sqrt{r} \sin \frac{1}{2}\theta = \sqrt{\frac{1}{2}(r - r \cos \theta)},$$

use  $r \cos \theta = x$ , and finally choose the sign of  $\operatorname{Im} \sqrt{z}$  in such a way that  $\operatorname{sign}[(\operatorname{Re} \sqrt{z})(\operatorname{Im} \sqrt{z})] = \operatorname{sign} y$ .

**(c)**  $\pm\sqrt{2}(1 + i)$ ,  $\pm(5 - 3i)$ ,  $\pm(4 + \sqrt{7}i)$

**28.**  $z^2 = 2i$ ,  $-5 + 12i$ ,  $z = \pm(1 + i)$ ,  $\pm(2 + 3i)$  by (19)

**30.**  $z^2 = \pm 4i$ ,  $z = \pm(1 \pm i)\sqrt{2}$ . One of the two factors is

$$(z - (1 + i)\sqrt{2})(z - (1 - i)\sqrt{2}) = z^2 - 2\sqrt{2}z + 4$$

and the other is

$$(z - (-1 + i)\sqrt{2})(z - (-1 - i)\sqrt{2}) = z^2 + 2\sqrt{2}z + 4.$$

The product equals  $z^4 + 16$ .

**32.**  $|z| = \sqrt{x^2 + y^2} \geq |x|$ , etc.

### SECTION 13.3. Derivative. Analytic Function, page 612

**Purpose.** To define (complex) analytic functions—the class of functions complex analysis is concerned with—and the concepts needed for that definition, in particular, derivatives.

This is preceded by a collection of a few standard concepts on sets in the complex plane that we shall need from time to time in the chapters on complex analysis.

#### Main Content, Important Concepts

Unit circle, unit disk, open and closed disks

Domain, region

Complex function

Limit, continuity

Derivative

Analytic function

#### Comment on Content

The most important concept in this section is that of an **analytic function**. The other concepts resemble those of real calculus. The most important new *idea* is connected with the **limit**: the approach in infinitely many possible directions. This yields the negative result in Example 4 and—much more importantly—the **Cauchy–Riemann equations** in the next section.

### SOLUTIONS TO PROBLEM SET 13.3, page 617

2. Closed annulus bounded by circles of radii 1 and 5 centered at  $1 - 4i$
4. Open vertical strip of width  $2\pi$
6. Open half-plane extending from the vertical line  $x = -1$  to the right



8. Angular region of angle  $\pi/2$  symmetric to the positive  $x$ -axis

10. We obtain

$$\operatorname{Re} \frac{1}{z} = \frac{x}{x^2 + y^2} < 1, \quad x < x^2 + y^2, \quad \frac{1}{4} < \left(x - \frac{1}{2}\right)^2 + y^2.$$

This is the exterior of the circle of radius  $\frac{1}{2}$  centered at  $\frac{1}{2}$ .

12.  $3x^2 - 3y^2 - 6x + i(6xy - 6y + 3)$ ; the value is  $-3 + 9i$ .

14. The given function is (multiply by  $1 - \bar{z}$ )

$$f = \frac{1 - x + iy}{(1 - x)^2 + y^2}$$

which shows  $\operatorname{Re} f$  and  $\operatorname{Im} f$ . The value at the given  $z$  is  $1.6 + 0.8i$ .

16. No, since  $r^2(\cos 2\theta)/r^2 = \cos 2\theta$

18. Yes, since  $(r^2/r) \cos \theta \rightarrow 0$  as  $r \rightarrow 0$ .

$$20. \left(1 - \frac{10}{z^2 + 1}\right)' = \frac{20z}{(z^2 + 1)^2}$$

22. 0. This is the case in which a linear fractional transformation (Möbius transformation) has derivative identically zero. We shall discuss this in Sec. 17.2. The given function equals  $-2i$ .

$$24. \frac{2z}{(z+i)^2} - \frac{2z^2}{(z+i)^3} = \frac{2iz}{(z+i)^3}$$

26. **Team Project.** (a) Use  $\operatorname{Re} f(z) = [f(z) + \overline{f(z)}]/2$ ,  $\operatorname{Im} f(z) = [f(z) - \overline{f(z)}]/2i$ .

(b) Assume that  $\lim_{z \rightarrow z_0} f(z) = l_1$ ,  $\lim_{z \rightarrow z_0} f(z) = l_2$ ,  $l_1 \neq l_2$ . For every  $\epsilon > 0$  there are  $\delta_1 > 0$  and  $\delta_2 > 0$  such that

$$|f(z) - l_j| < \epsilon \quad \text{when} \quad 0 < |z - z_0| < \delta_j, \quad j = 1, 2.$$

Hence for  $\epsilon = |l_1 - l_2|/2$  and  $0 < |z - z_0| < \delta$ , where  $\delta \leq \delta_1$ ,  $\delta \leq \delta_2$ , we have

$$\begin{aligned} |l_1 - l_2| &= |[f(z) - l_2] - [f(z) - l_1]| \\ &\leq |f(z) - l_2| + |f(z) - l_1| < 2\epsilon = |l_1 - l_2|. \end{aligned}$$

(c) By continuity, for any  $\epsilon > 0$  there is a  $\delta > 0$  such that  $|f(z) - f(a)| < \epsilon$  when  $|z - a| < \delta$ . Now  $|z_n - a| < \delta$  for all sufficiently large  $n$  since  $\lim z_n = a$ . Thus  $|f(z_n) - f(a)| < \epsilon$  for these  $n$ .

(d) The proof is as in calculus. We write

$$\frac{f(z) - f(z_0)}{z - z_0} - f'(z_0) = \eta.$$

Then from the definition of a limit it follows that for any given  $\epsilon > 0$  there is a  $\delta > 0$  such that  $|\eta| < \epsilon$  when  $|z - z_0| < \delta$ . From this and the triangle inequality,

$$|f(z) - f(z_0)| = |z - z_0| |f'(z_0) + \eta| \leq |z - z_0| |f'(z_0)| + |z - z_0| \epsilon,$$

which approaches 0 as  $|z - z_0| \rightarrow 0$ .

(e) The quotient in (4) is  $\Delta x/\Delta z$ , which is 0 if  $\Delta x = 0$  but 1 if  $\Delta y = 0$ , so that it has no limit as  $\Delta z \rightarrow 0$ .

$$(f) \frac{f(z + \Delta z) - f(z)}{\Delta z} = \frac{(z + \Delta z)(\bar{z} + \overline{\Delta z}) - z\bar{z}}{\Delta z} = z \frac{\overline{\Delta z}}{\Delta z} + \bar{z} + \overline{\Delta z}.$$

When  $z = 0$  the expression on the right approaches zero as  $\Delta z \rightarrow 0$ . When  $z \neq 0$  and  $\Delta z = \Delta x$ , then  $\overline{\Delta z} = \Delta x$  and that expression approaches  $z + \bar{z}$ . When  $z \neq 0$  and  $\Delta z = i\Delta y$ , then  $\overline{\Delta z} = -i\Delta y$  and that expression approaches  $-z + \bar{z}$ . This proves the statement.

### SECTION 13.4. Cauchy–Riemann Equations. Laplace's Equation, page 618

**Purpose.** To derive and explain the most important equations in this chapter, the Cauchy–Riemann equations, a system of two PDEs, which constitute the basic criterion for analyticity.

#### Main Content, Important Concepts

Cauchy–Riemann equations (1)

These equations as a criterion for analyticity (Theorems 1 and 2)

Derivative in terms of partial derivatives, (4), (5)

Relation of analytic functions to Laplace's equation

Harmonic function, harmonic conjugate

#### Comment on Content

(4), (5), and Example 3 will be needed occasionally.

The relation to Laplace's equation is basic, as mentioned in the text.

### SOLUTIONS TO PROBLEM SET 13.4, page 623

2. No
4. Yes when  $z \neq \pm 1, \pm i$
6. No
8. Yes
10. Yes when  $z \neq 0$
12.  $f(z) = -iz^2/2$
14.  $f(z) = 1/z$
16.  $f(z) = -\text{Arg } z + i \ln |z|$
18. No
20.  $f(z) = \cos x \cosh y - i \sin x \sinh y = \cos z$  (to be introduced in Sec. 13.6)
22.  $a = 3, e^{3x} \sin 3y$
24.  $a = b = 0, v = \text{const}$
26. **Team Project.** (a)  $u = \text{const}, u_x = u_y = 0, v_x = v_y = 0$  by (1),  $v = \text{const}$ , and  $f = u + iv = \text{const}$ .  
 (b) Same idea as in (a).  
 (c)  $f' = u_x + iv_x = 0$  by (4). Hence  $v_y = 0, u_y = 0$  by (1),  $f = u + iv = \text{const}$ .

### SECTION 13.5. Exponential Function, page 623

**Purpose.** Sections 13.5–13.7 are devoted to the most important elementary functions in complex, which generalize the corresponding real functions, and we emphasize properties that are not apparent in real.

**Basic Properties of the Exponential Function**

Derivative and functional relation as in real

Euler formula, polar form of  $z$ Periodicity with  $2\pi i$ , fundamental region $e^z \neq 0$  for all  $z$ **SOLUTIONS TO PROBLEM SET 13.5, page 626**

2.  $-20.086, 20.086$   
 4.  $-ie^{\sqrt{2}} = -4.11325i, 4.11325$   
 6.  $-e^\pi = -23.1407, 23.1407$   
 8.  $i, 1$   
 10.  $\exp(x^3 - 3xy^2)(\cos(3x^2y - y^3) + i(\sin(3x^2y - y^3)))$   
 12.  $e^{1/z} = \exp\left(\frac{x}{x^2 + y^2}\right)\left(\cos\frac{y}{x^2 + y^2} - i\sin\frac{y}{x^2 + y^2}\right)$   
 14.  $\sqrt{2} e^{\pi i/4}$   
 16.  $5 \exp(i \arctan \frac{4}{3})$   
 18.  $z = \frac{1}{3}(\ln 4 \pm 2n\pi i), n = 0, 1, \dots$   
 20. No solutions  
 22. **Team Project.** (a)  $e^{1/z}$  is analytic for all  $z \neq 0$ .  $e^{\bar{z}}$  is not analytic for any  $z$ . The last function is analytic if and only if  $k = 1$ .  
 (b) (i)  $e^x \sin y = 0, \sin y = 0$ . *Answer:* On the horizontal lines  $y = \pm n\pi, n = 0, 1, \dots$ . (ii)  $e^{-x} < 1, x > 0$  (the right half-plane).  
 (iii)  $e^{\bar{z}} = e^{x-iy} = e^x(\cos y - i \sin y) = \overline{e^x(\cos y + i \sin y)} = \overline{e^z}$ . *Answer:* All  $z$ .  
 (d)  $f' = u_x + iv_x = f = u + iv$ , hence  $u_x = u, v_x = v$ . By integration,

$$u = c_1(y)e^x, \quad v = c_2(y)e^x.$$

By the first Cauchy–Riemann equation,

$$u_x = v_y = c_2' e^x, \quad \text{thus} \quad c_1 = c_2' \quad ( ' = d/dy).$$

By the second Cauchy–Riemann equation,

$$u_y = c_1' e^x = -v_x = -c_2 e^x, \quad \text{thus} \quad c_1' = -c_2.$$

Differentiating the last equation with respect to  $y$ , we get

$$c_1'' = -c_2' = -c_1, \quad \text{hence} \quad c_1 = a \cos y + b \sin y.$$

Now for  $y = 0$  we must have

$$\begin{aligned} u(x, 0) &= c_1(0)e^x = e^x, & c_1(0) &= 1, & a &= 1, \\ v(x, 0) &= c_2(0)e^x = 0, & c_2(0) &= 0. \end{aligned}$$

Also,  $b = c_1'(0) = -c_2(0) = 0$ . Together  $c_1(y) = \cos y$ . From this,

$$c_2(y) = -c_1'(y) = \sin y.$$

This gives  $f(z) = e^x(\cos y + i \sin y)$ .

**SECTION 13.6. Trigonometric and Hyperbolic Functions, page 626**

**Purpose.** Discussion of basic properties of trigonometric and hyperbolic functions, with emphasis on the relations between these two classes of functions as well as between them and the exponential function; here we see on an elementary level that investigation of special functions in complex can add substantially to their understanding.

**Main Content**

- Definitions of  $\cos z$  and  $\sin z$  (1)
- Euler's formula in complex (5)
- Definitions of  $\cosh z$  and  $\sinh z$  (11)
- Relations between trigonometric and hyperbolic functions
- Real and imaginary parts (6) and Prob. 3

**SOLUTIONS TO PROBLEM SET 13.6, page 629**

4. The right side is

$$\begin{aligned} & \cosh z_1 \cosh z_2 + \sinh z_1 \sinh z_2 \\ &= \frac{1}{4} (e^{z_1} + e^{-z_1})(e^{z_2} + e^{-z_2}) + \frac{1}{4} (e^{z_1} - e^{-z_1})(e^{z_2} - e^{-z_2}). \end{aligned}$$

If we multiply out, then because of the minus signs the products  $e^{z_1}e^{-z_2}$  and  $e^{-z_1}e^{z_2}$  cancel in pairs. There remains, as asserted,

$$2 \cdot \frac{1}{4}(e^{z_1+z_2} + e^{-z_1-z_2}) = \cosh(z_1 + z_2).$$

Similarly for the other formula.

- 6. Special case of the first formula in Prob. 4.
- 8.  $\sin 1 \cosh 1 + i \cos 1 \sinh 1 = 1.2985 + 0.63496i$
- 10.  $\cosh 3\pi = 6195.8$
- 12. The two expressions are equal because of (14) or (15). We thus obtain, for instance,

$$\sin(2 + \pi i) = \sin 2 \cosh \pi + i \cos 2 \sinh \pi = 10.541 - 4.8060i.$$

14.  $\sinh 4 \cos 3 - i \cosh 4 \sin 3 = -27.017 - 3.8537i$

16. We obtain

$$\tan z = \frac{\sin z}{\cos z} = \frac{\sin z \overline{\cos z}}{|\cos z|^2}.$$

Hence the denominator is (use  $\cosh^2 y = \sinh^2 y + 1$  to simplify)

$$\cos^2 x \cosh^2 y + \sin^2 x \sinh^2 y = \cos^2 x + \sinh^2 y.$$

Insert  $\sin z$  and  $\cos z$  into the numerator and multiply out. Then for the real part of the product you get

$$\sin x \cos x \cosh^2 y - \cos x \sin x \sinh^2 y = \sin x \cos x$$

and for the imaginary part, using  $\sin^2 x + \cos^2 x = 1$ , you get

$$\sin^2 x \cosh y \sinh y + \cos^2 x \cosh y \sinh y = \cosh y \sinh y.$$

18.  $\cos x \sinh y = 0$ ,  $x = \frac{1}{2}\pi \pm 2n\pi$ ,  $\cosh y = 100$ ,  $\cosh y \approx \frac{1}{2}e^y$  for large  $y$ ,  $e^y \approx 200$ ,  $y \approx 5.29832$  (agrees to 4D with the solution of  $\cosh y = 100$ ).

$$\text{Answer: } z = \frac{1}{2}\pi \pm 2n\pi \pm 5.29832i.$$

20. (a)  $\cosh x \cos y = -1$ , (b)  $\sinh x \sin y = 0$ . From (b) we have  $x = 0$  or  $y = \pm n\pi$ . Then  $y = (2n + 1)\pi$  and  $x = 0$  from (a). *Answer:  $z = (2n + 1)\pi i$ .*

22. (a)  $\sin x \sinh y = 0$ ,  $y = 0$  or  $x = n\pi$  (parallels to the  $y$ -axis)

(b)  $\cos x \sinh y = 0$ ,  $y = 0$  or  $x = \frac{1}{2}(2n + 1)\pi$ , where  $n = 0, \pm 1, \pm 2, \dots$

24. From (7a) we obtain

$$|\cos z|^2 = \cos^2 x + \sinh^2 y = \cos^2 x + \cosh^2 y - 1.$$

Hence  $|\cos z|^2 \geq \sinh^2 y$  from the first equality, and  $|\cos z|^2 \leq \cosh^2 y$  from the second equality. Now take the square root.

The inequality for  $|\sin z|$  is obtained similarly.

### SECTION 13.7. Logarithm. General Power, page 630

**Purpose.** Discussion of the complex logarithm, which extends the real logarithm  $\ln x$  (defined for positive  $x$ ) to an infinitely many-valued relation (3) defined for all  $z \neq 0$ ; definition of general powers  $z^c$ .

#### Comment on Notation

$\ln z$  is also denoted by  $\log z$ , but for the engineer, who also needs logarithms  $\log x$  of base 10, the notation  $\ln$  is more practical; this notation is widely used in mathematics.

#### Important Formulas

Real and imaginary parts (1)

Relation of the principal value to the other values (3)

Relations between  $\ln$  and the exponential function (4)

Functional relation in complex (5)

Derivative (6)

General power (8)

### SOLUTIONS TO PROBLEM SET 13.7, page 633

2.  $\frac{1}{2} \ln 8 + \frac{1}{4}\pi i$
4.  $\ln 5.001 \pm 0.02i$  (approximately)
6.  $\ln 100 + \pi i = 4.605 + 3.142i$
8.  $1 - \frac{1}{2}\pi i$
10.  $\pm 2n\pi i$ ,  $n = 0, 1, \dots$
12.  $1 \pm 2n\pi i$ ,  $n = 0, 1, \dots$
14.  $\ln 5 + (\arctan \frac{3}{4} \pm 2n\pi)i$ ,  $n = 0, 1, \dots$
16.  $\ln |e^{3i}| + i \arctan \left( \frac{\sin 3}{\cos 3} \right) \pm 2n\pi i = 0 + 3i \pm 2n\pi i$ ; see also (4b).
18.  $-e^{2\pi i}$
20.  $e^{e-\pi i} = -e^e = -15.154$

$$\begin{aligned}
 22. \quad i^{2i} &= e^{2i \operatorname{Ln} i} = e^{2i \cdot i\pi/2} = e^{-\pi}, \\
 (2i)^i &= e^{i \operatorname{Ln} 2i} = e^{i(\ln 2 + \pi i/2)} = e^{-\pi/2} [\cos(\ln 2) + i \sin(\ln 2)] \\
 24. \quad e^{(1+i)\operatorname{Ln}(1-i)} &= e^{(1+i)(\ln\sqrt{2} - \pi i/4)} \\
 &= \exp(\ln\sqrt{2} - \pi i/4 + i \ln\sqrt{2} + \pi/4) \\
 &= \sqrt{2} e^{\pi/4} (\cos(-\frac{1}{4}\pi + \ln\sqrt{2}) + i \sin(-\frac{1}{4}\pi + \ln\sqrt{2})) \\
 &= 2.8079 - 1.3179i.
 \end{aligned}$$

Note that this is the complex conjugate of the answer to Prob. 25.

$$26. \quad e^{(1-2i)\operatorname{Ln}(-1)} = e^{(1-2i)\pi i} = e^{\pi i + 2\pi} = -e^{2\pi}$$

28. We obtain

$$\begin{aligned}
 \exp\left(\frac{1}{3} \operatorname{Ln}(3 - 4i)\right) &= \exp\left(\frac{1}{3}(\ln 5 - i \arctan \frac{4}{3})\right) \\
 &= \sqrt[3]{5} \left[\cos\left(\frac{1}{3} \arctan \frac{4}{3}\right) - i \sin\left(\frac{1}{3} \arctan \frac{4}{3}\right)\right] \\
 &= 1.6289 - 0.5202i.
 \end{aligned}$$

30. **Team Project.** (a)  $w = \arccos z$ ,  $z = \cos w = \frac{1}{2}(e^{iw} + e^{-iw})$ . Multiply by  $2e^{iw}$  to get a quadratic equation in  $e^{iw}$ ,

$$e^{2iw} - 2ze^{iw} + 1 = 0.$$

A solution is  $e^{iw} = z + \sqrt{z^2 - 1}$ , and by taking logarithms we get the given formula

$$\arccos z = w = -i \ln(z + \sqrt{z^2 - 1}).$$

(b) Similarly,

$$z = \sin w = \frac{1}{2i}(e^{iw} - e^{-iw}),$$

$$2iz e^{iw} = e^{2iw} - 1,$$

$$e^{2iw} - 2iz e^{iw} - 1 = 0,$$

$$e^{iw} = iz + \sqrt{-z^2 + 1}.$$

Now take logarithms, etc.

(c)  $\cosh w = \frac{1}{2}(e^w + e^{-w}) = z$ ,  $(e^w)^2 - 2ze^w + 1 = 0$ ,  $e^w = z + \sqrt{z^2 - 1}$ . Take logarithms.

(d)  $z = \sinh w = \frac{1}{2}(e^w - e^{-w})$ ,  $2ze^w = e^{2w} - 1$ ,  $e^w = z + \sqrt{z^2 + 1}$ . Take logarithms.

$$(e) \quad z = \tan w = \frac{\sin w}{\cos w} = -i \frac{e^{iw} - e^{-iw}}{e^{iw} + e^{-iw}} = -i \frac{e^{2iw} - 1}{e^{2iw} + 1},$$

$$e^{2iw} = \frac{i - z}{i + z}, \quad w = \frac{1}{2i} \ln \frac{i - z}{i + z} = \frac{i}{2} \ln \frac{i + z}{i - z}$$

(f) This is similar to (e).

### SOLUTIONS TO CHAP. 13 REVIEW QUESTIONS AND PROBLEMS, page 634

$$2. \quad 5\sqrt{29} e^{-0.2630i}, 5e^{0.9273i}$$

$$16. \quad (2i)^6 = -64$$

$$18. \quad 3/58 + (7/58)i$$

20.  $\pm(2 - 3i)$
22.  $\sqrt{10} e^{-i \arctan 3} = 3.1623 e^{-1.2490i}$
24.  $e^{-i \arctan(1/2)}$
26.  $\sqrt{8} e^{\pi i/4}$
28.  $\pm 4, \pm 4i$
30.  $\pm(6 - 2i)$
32.  $f(z) = -e^{-3z}$
34.  $f(z) = \cos 2z$
36. No
38.  $-e^{-x/2} \sin \frac{1}{2}y$ . Problems 36–39 are in principle of the same kind as Probs. 31–35. We have included them here as a reminder that in using real or imaginary parts of an analytic function we are dealing with harmonic functions (to whose applications a whole chapter (Chap. 18) will be devoted, perhaps as the most important aspect of complex analysis from the viewpoint of the engineer and physicist).
40.  $\sin 3 \cosh 4\pi + i \cos 3 \sinh 4\pi = 20233 - 141941i$ . This is a reminder of the growth of the complex sine, as opposed to the sine in calculus whose absolute value never gets greater than 1 for all real  $x$ .
42.  $-\cosh 2 = -3.7622$
44. We obtain

$$\frac{\sin 1 \cos 1 + i \sinh 1 \cosh 1}{\cos^2 1 + \sinh^2 1} = 0.2718 + 1.0839i.$$

## CHAPTER 14 Complex Integration

### Change

We now discuss the two main integration methods (indefinite integration and integration by the use of the representation of the path) directly after the definition of the integral, postponing the proof of the first of these methods until Cauchy's integral formula is available in Sec. 14.2. This order of the material seems desirable from a practical point of view.

### Comment

The introduction to the chapter mentions two reasons for the importance of complex integration. Another practical reason is the extensive use of complex integral representations in the higher theory of special functions; see for instance, Ref. [GR10] listed in App. 1.

### SECTION 14.1. Line Integral in the Complex Plane, page 637

**Purpose.** To discuss the definition, existence, and general properties of complex line integrals. Complex integration is rich in methods, some of them very elegant. In this section we discuss the first two methods, integration by the use of path and (under suitable assumptions given in Theorem 1!) by indefinite integration.

#### Main Content, Important Concepts

- Definition of the complex line integral
- Existence
- Basic properties
- Indefinite integration (Theorem 1)
- Integration by the use of path (Theorem 2)
- Integral of  $1/z$  around the unit circle (basic!)
- $ML$ -inequality (13) (needed often in our work)

#### Comment on Content

Indefinite integration will be justified in Sec. 14.2, after we have obtained Cauchy's integral theorem. We discuss this method here for two reasons: (i) to get going a little faster and, more importantly, (ii) to answer the students' natural question suggested by calculus, that is, whether the method works and under what condition—that it does not work unconditionally can be seen from Example 7!

### SOLUTIONS TO PROBLEM SET 14.1, page 645

2. Vertical straight segment from  $5 + 6i$  to  $5 - 6i$
4. Circle, center  $1 + i$ , radius 1, oriented clockwise, touching the axes
6. Semicircle, center  $3 + 4i$ , radius 5, passing through the origin
8. Portion of the parabola  $y = 2(x - 1)^2$  from  $-1 + 8i$  to  $3 + 8i$ , apex at  $x = 1$
10.  $z(t) = 1 + i + (3 - 3i)t$  ( $0 \leq t \leq 1$ )
12.  $z(t) = a + ib + [c - a + i(d - b)]t$  ( $0 \leq t \leq 1$ )



14.  $z(t) = a \cos t + ib \sin t \quad (0 \leq t \leq \pi)$   
 16.  $z(t) = 2 - 3i + 4e^{it} \quad (0 \leq t \leq 2\pi)$  counterclockwise. For clockwise orientation the exponent is  $-it$ .  
 18. Ellipse,  $z(t) = 1 + 3 \cos t + (-2 + 2 \sin t)i \quad (0 \leq t \leq 2\pi)$   
 20.  $z(t) = t + it^2 \quad (0 \leq t \leq 1)$ ,  $dz = (1 + 2it) dt$ ,  $\operatorname{Re} z(t) = t$ , so that

$$\int_0^1 t(1 + 2it) dt = \frac{1}{2} + \frac{2}{3}i.$$

This differs from Prob. 19. The integrand is not analytic!

22.  $-\cos z \Big|_0^{2i} = 1 - \cosh 2$  by the first method  
 24. By linearity we can integrate the two terms separately. The integral of  $z$  is 0 by Theorem 1. The integral of  $1/z$  is  $2\pi i$ ; see Example 5.  
 26.  $z(t) = t + it^2 \quad (-1 \leq t \leq 1)$ ,  $\dot{z}(t) = 1 + 2it$ ,  $\bar{z} = t - it^2$ , so that

$$\int_{-1}^1 (t - it^2)(1 + 2it) dt = \int_{-1}^1 (2t^3 + it^2 + t) dt = \frac{1}{3}it^3 \Big|_{-1}^1 = \frac{2}{3}i.$$

28.  $\operatorname{Im} z^2 = 2xy$  is 0 on the axes. Thus the only contribution to the integral comes from the segment from 1 to  $i$ , represented by, say,

$$z(t) = 1 - t + it \quad (0 \leq t \leq 1).$$

Hence  $\dot{z}(t) = -1 + i$ , and the integral is

$$\int_0^1 2(1-t)t(-1+i) dt = 2(-1+i) \int_0^1 (t-t^2) dt = \frac{1}{3}(-1+i).$$

30.  $\frac{1}{3}z^3 \Big|_{-1-i}^{1+i} = -\frac{4}{3} + \frac{4}{3}i$ , etc.  
 32.  $|\operatorname{Re} z| = |x| \leq 1 = M$  on  $C$ ,  $L = \sqrt{2}$ . The absolute value of the integral is  $1/\sqrt{2}$  (see the answer to Prob. 19).

Applications will show that the point of the  $ML$ -inequality is to have an upper bound, regardless of how accurate it is. In a typical application the bound is used to show that a quantity remains bounded, in particular in some limit process, or sometimes may go to 0 in the limit. This point should be emphasized and explained to the student when applications arise in further work.

34. **Team Project.** (b) (i)  $12.8i$ , (ii)  $\frac{1}{2}(e^{2+4i} - 1)$   
 (c) The integral of  $\operatorname{Re} z$  equals  $\frac{1}{2}\pi^2 - 2ai$ . The integral of  $z$  equals  $\frac{1}{2}\pi^2$ . The integral of  $\operatorname{Re}(z^2)$  equals  $\pi^3/3 - \pi a^2/2 - 2a\pi i$ . The integral of  $z^2$  equals  $\pi^3/3$ .  
 (d) The integrals of the four functions in (c) have for the present paths the values  $\frac{1}{2}a\pi i$ , 0,  $(4a^2 - 2)i/3$ , and  $-2i/3$ , respectively.

Parts (c) and (d) may also help in motivating further discussions on path independence and the principle of deformation of path.

## SECTION 14.2. Cauchy's Integral Theorem, page 646

**Purpose.** To discuss and prove the most important theorem in this chapter, Cauchy's integral theorem, which is basic by itself and has various basic consequences to be discussed in the remaining sections of the chapter.

**Main Content, Important Concepts**

- Simply connected domain
- Cauchy's integral theorem, Cauchy's proof  
(Goursat's proof in App. 4)
- Independence of path
- Principle of deformation of path
- Existence of indefinite integral
- Extension of Cauchy's theorem to multiply connected domains

**SOLUTIONS TO PROBLEM SET 14.2, page 653**

2. 0, yes, since  $3z = \pi i$ ,  $z = \pi i/3$  lies outside the unit circle.
4.  $1/\bar{z} = 1/e^{-it} = e^{it}$ ; hence  $dz/\bar{z} = e^{it}ie^{it} dt$ . Answer: 0, no
6. 0, yes, because  $\cos(z/2) = 0$  for  $z = \pm\pi$  etc., and these points lie outside the unit circle.
8.  $1/(4z - 3) = \frac{1/4}{z - 3/4}$ , so that the integral equals  $\frac{1}{4} \cdot 2\pi i = \frac{1}{2}\pi i$  by the principle of deformation of path. The theorem does not apply.
10. 0, no; here  $\bar{z}^2 dz = e^{-2it}ie^{it} dt$ .
12. (a) Yes. (b) No, since we would have to move the contour across  $\pm 2i$ , where  $1/(z^2 + 4)$  is not analytic.
14. (a)  $z = 0$  outside  $C$ , (b)  $z = 0, \pm 1, \pm i$  outside  $C$ , (c)  $0, \pm 3i$  outside  $C$ .
16. No, because of the principle of deformation of path.
18. **Team Project.** (b) (i)  $\frac{2z + 3i}{z^2 + 1/4} = \frac{4}{z - i/2} - \frac{2}{z + i/2}$ . From this, the principle of deformation of path, and (3) we obtain the answer

$$4 \cdot 2\pi i - 2 \cdot 2\pi i = 4\pi i.$$

(ii) Similarly,

$$\frac{z + 1}{z^2 + 2z} = \frac{1/2}{z} + \frac{1/2}{z + 2}.$$

Now  $z = -2$  lies outside the unit circle. Hence the answer is  $\frac{1}{2} \cdot 2\pi i = \pi i$ .

(c) The integral of  $z, \operatorname{Im} z, z^2, \operatorname{Re} z^2, \operatorname{Im} z^2$  equals  $1/2, a/6, 1/3, 1/3 - a^2/30 - ia/6, a/6 - ia^2/30$ , respectively. Note that the integral of  $\operatorname{Re} z^2$  plus  $i$  times the integral of  $\operatorname{Im} z^2$  must equal  $1/3$ . Of course, the student should feel free to experiment with any functions whatsoever.

20.  $\cosh z = 0$  at  $\pm\pi i/2, \pm 3\pi i/2, \dots$ , which all lie outside  $C$ . Answer: 0.
22. The partial fraction reduction is

$$\frac{3}{z} + \frac{4}{z - 2}.$$

Answer:  $2\pi i(3 + 4) = 14\pi i$ .

24. 0
26. 0, because the branch cut extends from  $-2$  to the left, outside  $C$ .

28. The partial fraction reduction is

$$\frac{1}{2i} \left( \frac{1}{z-i} - \frac{1}{z+i} \right).$$

Answer: (a)  $2\pi i(-1/2i) = -\pi$ , (b)  $\pi$

30. 0, because  $z = \pm\pi, \pm 3\pi, \dots$  as well as  $\pm 2$  and  $\pm 2i$  lie outside the contour  $C$ .

### SECTION 14.3. Cauchy's Integral Formula, page 654

**Purpose.** To prove, discuss, and apply Cauchy's integral formula, the second major consequence of Cauchy's integral theorem (the first being the justification of indefinite integration).

#### Comment on Examples

The student has to find out how to write the integrand as a product  $f(z)$  times  $1/(z - z_0)$ , and the examples (particularly Example 3) and problems are designed to give help in that technique.

### SOLUTIONS TO PROBLEM SET 14.3, page 657

2. 0 by Cauchy's integral theorem;  $\pm 2i$  lie outside  $C$ .

4. 0 by Cauchy's integral theorem

6.  $f(z) = e^{3z}/3$ . Answer:  $\frac{1}{3} \cdot 2\pi i e^i = \frac{2}{3}\pi i(\cos 1 + i \sin 1) = -1.7624 + 1.1316i$

8.  $z_0 = 1$ . Answer:  $2\pi i/2 = \pi i$

10.  $z_0 = 2i$ . Answer:  $2\pi i e^{2i} = -2\pi \sin 2 + 2\pi i \cos 2 = -5.7133 - 2.6147i$

12.  $2\pi i \tan i = -2\pi \tanh 1 = -4.7852$

14.  $z_0 = i$  lies inside  $|z - 2i| = 2$ , and the corresponding integral equals

$$\begin{aligned} 2\pi i(\operatorname{Ln}(1+i))/(2i) &= \pi \operatorname{Ln}(1+i) \\ &= \pi(\ln \sqrt{2} + \frac{1}{4}\pi i) = 1.089 + 2.467i. \end{aligned}$$

The integral over the other circle is 0 because  $z_0 = -i$  lies outside.

16.  $z = 2i$  lies in the annulus bounded by the two given circles of  $C$ , but  $z = 0$  does not. We thus obtain

$$2\pi i \frac{\sin z}{z} \Big|_{z=2i} = \pi i \sinh 2 = 11.394i.$$

18. For  $z_1 = z_2$  use Example 6 in Sec. 14.1 with  $m = -2$ . For  $z_1 \neq z_2$  use partial fractions

$$\frac{1}{(z-z_1)(z-z_2)} = \frac{1}{(z_1-z_2)(z-z_1)} - \frac{1}{(z_1-z_2)(z-z_2)}.$$

20. **Team Project.** (a) Eq. (2) is

$$\begin{aligned} \oint_C \frac{z^3 - 6}{z - \frac{1}{2}i} dz &= \left[ \left( \frac{i}{2} \right)^3 - 6 \right] \oint_C \frac{dz}{z - \frac{1}{2}i} + \oint_C \frac{z^3 - (\frac{1}{2}i)^3}{z - \frac{1}{2}i} dz \\ &= \left( -\frac{i}{8} - 6 \right) 2\pi i + \oint_C \left( z^2 + \frac{1}{2} iz - \frac{1}{4} \right) dz = \frac{1}{4} \pi - 12\pi i \end{aligned}$$

because the last integral is zero by Cauchy's integral theorem. The result agrees with that in Example 2, except for a factor 2.

(b) Using (12) in App. A3.1, we obtain (2) in the form

$$\begin{aligned}\oint_C \frac{\sin z}{z - \frac{1}{2}\pi} dz &= (\sin \frac{1}{2}\pi) \oint_C \frac{dz}{z - \frac{1}{2}\pi} + \oint_C \frac{\sin z - \sin \frac{1}{2}\pi}{z - \frac{1}{2}\pi} dz \\ &= 2\pi i + \oint_C \frac{2 \sin(\frac{1}{2}z - \frac{1}{4}\pi) \cos(\frac{1}{2}z + \frac{1}{4}\pi)}{z - \frac{1}{2}\pi} dz.\end{aligned}$$

As  $\rho$  in Fig. 354 approaches 0, the integrand approaches 0.

### SECTION 14.4. Derivatives of Analytic Functions, page 658

**Purpose.** To discuss and apply the most important consequence of Cauchy's integral formula, the theorem on the existence and form of the derivatives of an analytic function.

#### Main Content

Formulas for the derivatives of an analytic function (1)

Cauchy's inequality

Liouville's theorem

Morera's theorem (inverse of Cauchy's theorem)

#### Comments on Content

Technically the application of the formulas for derivatives in integration is practically the same as that in the last section.

The basic importance of (1) in giving the existence of all derivatives of an analytic function is emphasized in the text.

### SOLUTIONS TO PROBLEM SET 14.4, page 661

2.  $(2\pi i/3!)(-\cos(\pi/2)) = -(\pi i/3) \cosh \frac{1}{2}\pi$

4.  $(2\pi i/(2n)!)(-1)^n \cos 0 = (-1)^n \cdot 2\pi i/(2n)!$

6.  $z_0 = -1$  lies inside  $C$ . Hence the integral equals

$$2\pi i \left( \frac{1}{z+3} - \sin z \right) \Big|_{z=-1} = 2\pi i \left( \frac{1}{2} + \sin 1 \right) = 8.429i.$$

8.  $2\pi i e^a/(n-1)!$  if  $|a| < 2$  and 0 if  $|a| > 2$ .

10. 0 by Cauchy's integral theorem for a doubly connected domain; see (6) in Sec. 14.2.

12.  $z = 0$  lies outside the "annulus" bounded by the two circles of  $C$ . The point  $z = 2i$  lies inside the larger circle but outside the smaller. Hence the integral equals (differentiate once)

$$2\pi i \left( \frac{2e^{2z}}{z} - \frac{e^{2z}}{z^2} \right) \Big|_{z=2i} = 2\pi i \left( \frac{2e^{4i}}{2i} - \frac{e^{4i}}{-4} \right) = \pi e^{4i} \left( 2 + \frac{1}{2}i \right).$$

14. **Team Project. (a)** If no such  $z$  existed, we would have  $|f(z)| \leq M$  for every  $|z|$ , which means that the entire function  $f(z)$  would be bounded, hence a constant by Liouville's theorem.

(b) Let  $f(z) = c_0 + c_1z + \cdots + c_nz^n = z^n \left( c_n + \frac{c_{n-1}}{z} + \cdots + \frac{c_0}{z^n} \right)$ ,  $c_n \neq 0$ ,  $n > 0$ . Set  $|z| = r$ . Then

$$|f(z)| > r^n \left( |c_n| - \frac{|c_{n-1}|}{r} - \cdots - \frac{|c_0|}{r^n} \right)$$

and  $|f(z)| > \frac{1}{2}r^n|c_n|$  for sufficiently large  $r$ . From this the result follows.

(c)  $|e^z| > M$  for real  $z = x$  with  $x > R = \ln M$ . On the other hand,  $|e^z| = 1$  for any pure imaginary  $z = iy$  because  $|e^{iy}| = 1$  for any real  $y$  (Sec. 13.5).

(d) If  $f(z) \neq 0$  for all  $z$ , then  $g = 1/f$  would be analytic for all  $z$ . Hence by (a) there would be values of  $z$  exterior to every circle  $|z| = R$  at which, say,  $|g(z)| > 1$  and thus  $|f(z)| < 1$ . This contradicts (b). Hence  $f(z) \neq 0$  for all  $z$  cannot hold.

### SOLUTIONS TO CHAP. 14 REVIEW QUESTIONS AND PROBLEMS, page 662

16.  $(2 + i)^4 + (2 + i)^2 - ((-i)^4 + (-i)^2) = -4 + 28i$

18. 0

20.  $2\pi i(e^{z^2})' \Big|_{z=1} = 4\pi i e$

22.  $z_1(t) = t$  ( $0 \leq t \leq 4$ ),  $z_2(t) = 4 + it$  ( $0 \leq t \leq 3$ ). Answer:  $8 + 12i$

24. 0

26.  $z(t) = re^{it}$ . Hence

$$\int_0^{2\pi} (r \sin t) i r e^{it} dt = ir^2 \int_0^{2\pi} (\sin t \cos t + i \sin^2 t) dt = -\pi r^2.$$

28.  $2\pi i \pi / (\cos^2 \pi z) \Big|_{z=1} = 2\pi^2 i$

30.  $\frac{2\pi i}{2!} (6z - \sin z) \Big|_{z=i} = \pi i (6i - i \sinh 1) = \pi (\sinh 1 - 6) = -15.158$

## CHAPTER 15 Power Series, Taylor Series

Power series and, in particular, Taylor series, play a much more fundamental role in complex analysis than they do in calculus. The student may do well to review what has been presented about power series in calculus but should become aware that many new ideas appear in complex, mainly owing to the use of complex integration.

### SECTION 15.1. Sequences, Series, Convergence Tests, page 664

**Purpose.** The beginnings on sequences and series in complex is similar to that in calculus (differences between real and complex appear only later). Hence this section can almost be regarded as a review from calculus plus a presentation of convergence tests for later use.

#### Main Content, Important Concepts

Sequences, series, convergence, divergence

Comparison test (Theorem 5)

Ratio test (Theorem 8)

Root test (Theorem 10)

### SOLUTIONS TO PROBLEM SET 15.1, page 672

2. Bounded, divergent, 8 limit points (the values of  $\sqrt[8]{1}$ )
4. Unbounded, divergent
6. Bounded, convergent to 0 (the terms of the Maclaurin series of  $e^{3+4i}$ )
8. Divergent. All terms have absolute value 1.
10. Convergent to 0
12. Let  $\ell_1$  and  $\ell_2$  be two limits,  $d = |\ell_1 - \ell_2|$  and  $\epsilon = d/3$ . Then there is an  $N(\epsilon)$  such that

$$|z_n - \ell_1| < \epsilon, \quad |z_n - \ell_2| < \epsilon \quad \text{for all } n > N.$$

This is impossible because the disks  $|z - \ell_1| < \epsilon$  and  $|z - \ell_2| < \epsilon$  are disjoint.

14. The sequences are bounded,  $|z_n| < K$ ,  $|z_n^*| < K$ . Since they converge, for an  $\epsilon > 0$  there is an  $N$  such that  $|z_n - \ell| < \epsilon/(3K)$ ,  $|z_n^* - \ell^*| < \epsilon/(3|\ell|)$  ( $\ell \neq 0$ ; the case  $\ell = 0$  is rather trivial), hence

$$\begin{aligned} |z_n z_n^* - \ell \ell^*| &= |(z_n - \ell)z_n^* + (z_n^* - \ell^*)\ell| \\ &\leq |z_n - \ell| |z_n^*| + |z_n^* - \ell^*| |\ell| \\ &< \epsilon/3 + \epsilon/3 < \epsilon \quad (n > N). \end{aligned}$$

16. Convergent. Sum  $e^{10-15i}$

18. Convergent because  $\frac{1}{|n^2 - 2i|} < \frac{1}{n^2}$  and  $\sum_{n=1}^{\infty} \frac{1}{n^2}$  converges.

20. Divergent because  $1/\ln n > 1/n$  and the harmonic series diverges.

22. By the ratio test it converges because after simplification

$$\left| \frac{z_{n+1}}{z_n} \right| = \frac{(n+1)^3 |1+i|}{(3n+3)(3n+2)(3n+1)} \rightarrow \frac{\sqrt{2}}{27}.$$

24. Convergent by the ratio test because  $\left| \frac{(n+1)^2 (i/3)^{n+1}}{n^2 (i/3)^n} \right| \rightarrow \frac{1}{3}$

30. **Team Project.** (a) By the generalized triangle inequality (6\*), Sec. 13.2, we have

$$|z_{n+1} + \cdots + z_{n+p}| \leq |z_{n+1}| + |z_{n+2}| + \cdots + |z_{n+p}|.$$

Since  $|z_1| + |z_2| + \cdots$  converges by assumption, the sum on the right becomes less than any given  $\epsilon > 0$  for every  $n$  greater than a sufficiently large  $N$  and  $p = 1, 2, \dots$ , by Cauchy's convergence principle. Hence the same is true for the left side, which proves convergence of  $z_1 + z_2 + \cdots$  by the same theorem.

(c) The form of the estimate of  $R_n$  suggests we use the fact that the ratio test is a comparison test based on the geometric series. This gives

$$R_n = z_{n+1} + z_{n+2} + \cdots = z_{n+1} \left( 1 + \frac{z_{n+2}}{z_{n+1}} + \frac{z_{n+3}}{z_{n+1}} + \cdots \right),$$

$$\left| \frac{z_{n+2}}{z_{n+1}} \right| \leq q, \quad \left| \frac{z_{n+3}}{z_{n+1}} \right| = \left| \frac{z_{n+3}}{z_{n+2}} \frac{z_{n+2}}{z_{n+1}} \right| \leq q^2, \quad \text{etc.},$$

$$|R_n| \leq |z_{n+1}| (1 + q + q^2 + \cdots) = \frac{|z_{n+1}|}{1 - q}.$$

(d) For this series we obtain the test ratio

$$\begin{aligned} \frac{1}{2} \left| \frac{n+1+i}{n+1} \cdot \frac{n}{n+i} \right| &= \frac{n}{2(n+1)} \sqrt{\frac{(n+1)^2 + 1}{n^2 + 1}} \\ &= \frac{1}{2} \sqrt{\frac{n^4 + 2n^3 + 2n^2}{n^4 + 2n^3 + 2n^2 + 2n + 1}} < \frac{1}{2}; \end{aligned}$$

from this with  $q = 1/2$  we have

$$|R_n| \leq \frac{|z_{n+1}|}{1 - q} = \frac{|n+1+i|}{2^n(n+1)} = \frac{\sqrt{(n+1)^2 + 1}}{2^n(n+1)} < 0.05.$$

Hence  $n = 5$  (by computation), and

$$s = \frac{31}{32} + \frac{661}{960}i = 0.96875 + 0.688542i.$$

Exact to 6 digits is  $1 + 0.693147i$ .

### SECTION 15.2. Power Series, page 673

**Purpose.** To discuss the convergence behavior of power series, which will be basic to our further work (and which is simpler than that of series having arbitrary complex functions as terms).

**Comment.** Most complex power series appearing in practical work and applications have real coefficients because most of the complex functions of practical interest are obtained from calculus by replacing the real variable  $x$  with the complex variable  $z = x + iy$ , retaining the real coefficients. Accordingly, in the problem set we consider primarily power series with real coefficients, also because complex coefficients would neither provide additional difficulties nor contribute new ideas.

**Proof of the Assertions in Example 6**

$R = 1/\tilde{L}$  follows from  $R = 1/\tilde{l}$  by noting that in the case of convergence,  $\tilde{L} = \tilde{l}$  (the only limit point).  $\tilde{l}$  exists by the Bolzano–Weierstrass theorem, assuming boundedness of  $\{\sqrt[n]{|a_n|}\}$ . Otherwise,  $\sqrt[n]{|a_n|} > K$  for infinitely many  $n$  and any given  $K$ . Fix  $z \neq z_0$  and take  $K = 1/|z - z_0|$  to get

$$\sqrt[n]{|a_n(z - z_0)^n|} > K|z - z_0| = 1$$

and divergence for every  $z \neq z_0$  by Theorem 9, Sec. 15.1.

Now, by the definition of a limit point, for a given  $\epsilon > 0$  we have for infinitely many  $n$

$$\tilde{l} - \epsilon < \sqrt[n]{|a_n|} < \tilde{l} + \epsilon;$$

hence for all  $z \neq z_0$  and those  $n$ ,

$$(*) \quad (\tilde{l} - \epsilon)|z - z_0| < \sqrt[n]{|a_n(z - z_0)^n|} < (\tilde{l} + \epsilon)|z - z_0|.$$

The right inequality holds even for all  $n > N$  ( $N$  sufficiently large), by the definition of a *greatest* limit point.

Let  $\tilde{l} = 0$ . Since  $\sqrt[n]{|a_n|} \geq 0$ , we then have convergence to 0. Fix any  $z = z_1 \neq z_0$ . Then for  $\epsilon = 1/(2|z_1 - z_0|) > 0$  there is an  $N$  such that  $\sqrt[n]{|a_n|} < \epsilon$  for all  $n > N$ ; hence

$$|a_n(z_1 - z_0)^n| < \epsilon^n |z_1 - z_0|^n = \frac{1}{2^n},$$

and convergence for all  $z_1$  follows by the comparison test.

Let  $\tilde{l} > 0$ . We establish  $1/\tilde{l}$  as the radius of convergence of (1) by proving

convergence of the series (1) if  $|z - z_0| < 1/\tilde{l}$ ,

divergence of the series (1) if  $|z - z_0| > 1/\tilde{l}$ .

Let  $|z - z_0| < 1/\tilde{l}$ . Then, say,  $|z - z_0|\tilde{l} = 1 - b < 1$ . With this and  $\epsilon = b/(2|z - z_0|) > 0$  in (\*), for all  $n > N$ ,

$$\sqrt[n]{|a_n(z - z_0)^n|} < \tilde{l}|z - z_0| + \epsilon|z - z_0| = 1 - b + \frac{1}{2}b < 1.$$

Convergence now follows from Theorem 9, Sec. 15.1.

Let  $|z - z_0| > 1/\tilde{l}$ . Then  $|z - z_0|\tilde{l} = 1 + c > 1$ . With this and  $\epsilon = c/(2|z - z_0|) > 0$  in (\*), for infinitely many  $n$ ,

$$\sqrt[n]{|a_n(z - z_0)^n|} > \tilde{l}|z - z_0| - \epsilon|z - z_0| = 1 + c - \frac{1}{2}c > 1,$$

and divergence follows.

**SOLUTIONS TO PROBLEM SET 15.2, page 677**

4. Center  $-2i$ . In (6) we have

$$\frac{n^n(n+1)!}{n!(n+1)^{n+1}} = \frac{n^n}{(n+1)^n} = \frac{1}{(1+1/n)^n} \rightarrow \frac{1}{e}$$

as is shown in calculus.

6.  $0, \infty$  because by (6)

$$\frac{2^{100n}}{n!} \cdot \frac{(n+1)!}{2^{100(n+1)}} = \frac{n+1}{2^{100}} \rightarrow \infty.$$



8.  $0, \infty$ . The sum is the Bessel function  $J_0(z)$ .  
 10.  $0, \infty$ . The sum is  $\cosh 2z$ .  
 12.  $5, \sqrt{2}/4$ , where  $\sqrt{2} = |1 + i|$ .  
 14.  $0, \infty$ . The sum is  $\cos z$ .  
 16.  $\pi, |(5 - i)/(2 + 3i)| = \sqrt{2}$   
 18.  $-\pi i$ . In (6),

$$\frac{(4n)! \cdot 2^{n+1} (n+1)^4 (n!)^4}{2^n (n!)^4 (4n+4)(4n+3)(4n+2)(4n+1)(4n)!} \rightarrow \frac{2n^4}{(4n)^4} = \frac{1}{128}.$$

20. **Team Project.** (a) The faster the coefficients go to zero, the larger  $|a_n/a_{n+1}|$  becomes.  
 (b) (i) Nothing. (ii)  $R$  is multiplied by  $1/k$ . (iii) The new series has radius of convergence  $1/R$ .  
 (c) In Example 6 we took the first term of one series, then the first term of the other, and so on alternately. We could have taken, for instance, the first three terms of one series, then the first five terms of the other, then again three terms and five terms, and so on; or we could have mixed three or more series term by term.  
 (d) No because  $|30 + 10i| > |31 - 6i|$ .

### SECTION 15.3. Functions Given by Power Series, page 678

**Purpose.** To show what operations on power series are mathematically justified and to prove the basic fact that power series represent analytic functions.

#### Main Content

- Termwise addition, subtraction, and multiplication of power series
- Termwise differentiation and integration (Theorems 3, 4)
- Analytic functions and derivatives (Theorem 5)

#### Comment on Content

That a power series is the Taylor series of its sum will be shown in the next section.

### SOLUTIONS TO PROBLEM SET 15.3, page 682

2.  $1/4$ , where  $1/(n(n+1))$  can be produced by two integrations of the geometric series.  
 4.  $|z/\pi|^2 < 1$  by integrating a geometric series. Thus  $|z| < R = \pi$ .  
 6.  $\binom{n}{k} = \frac{n(n-1) \cdots (n-k+1)}{k!}$  consists of the fixed  $k!$ , which has no effect on  $R$ , and factors  $n(n-1) \cdots (n-k+1)$ , as obtained by differentiation. Since  $\sum (z/4)^n$  has  $R = 4$ , the answer is 4.  
 8.  $\infty$ , because  $2n(2n-1)$  results from differentiation, and for the coefficients without these factors we have in the Cauchy–Hadamard formula

$$\frac{1/n^n}{1/(n+1)^{n+1}} = \left(\frac{n+1}{n}\right)^n (n+1) \rightarrow \infty \quad \text{as } n \rightarrow \infty$$

10. 1, by applying Theorem 3 to  $z^{n+m}$

14. Set  $f = \sqrt[n]{n}$  and apply l'Hôpital's rule to  $\ln f$ ,

$$\lim_{n \rightarrow \infty} \ln f = \lim_{n \rightarrow \infty} \frac{\ln n}{n} = \lim_{n \rightarrow \infty} \frac{1/n}{1} = 0. \quad \text{Hence} \quad \lim_{n \rightarrow \infty} f = 1.$$

16. This is a useful formula for binomial coefficients. It follows from

$$\begin{aligned} (1+z)^p(1+z)^q &= \sum_{n=0}^p \binom{p}{n} z^n \sum_{m=0}^q \binom{q}{m} z^m \\ &= (1+z)^{p+q} = \sum_{r=0}^{p+q} \binom{p+q}{r} z^r \end{aligned}$$

by equating the coefficients of  $z^r$  on both sides. To get  $z^n z^m = z^r$  on the left, we must have  $n+m=r$ ; thus  $m=r-n$ , and this gives the formula in the problem.

18. The odd-numbered coefficients are zero because  $f(-z) = f(z)$  implies

$$a_{2m+1}(-z)^{2m+1} = -a_{2m+1}z^{2m+1} = a_{2m+1}z^{2m+1}.$$

20. **Team Project.** (a) Division of the recursion relation by  $a_n$  gives

$$\frac{a_{n+1}}{a_n} = 1 + \frac{a_{n-1}}{a_n}.$$

Take the limit on both sides, denoting it by  $L$ :

$$L = 1 + \frac{1}{L}.$$

Thus  $L^2 - L - 1 = 0$ ,  $L = (1 + \sqrt{5})/2 = 1.618$ , an approximate value reached after just ten terms.

(b) The list is

$$1, 1, 2, 3, 5, 8, 13, 21, 34, 55, 89, 144, 233.$$

In the recursion,  $a_n$  is the number of pairs of rabbits present and  $a_{n-1}$  is the number of pairs of offsprings from the pairs of rabbits present at the end of the preceding month.

(c) Using the hint, we calculate

$$(1 - z - z^2) \sum_{n=0}^{\infty} a_n z^n = \sum_{n=0}^{\infty} (a_n - a_{n-1} - a_{n-2}) z^n = 1$$

where  $a_{-1} = a_{-2} = 0$ , and Theorem 2 gives  $a_0 = 1$ ,  $a_1 - a_0 = 0$ ,

$a_n - a_{n-1} - a_{n-2} = 0$  for  $n = 2, 3, \dots$ . The converse follows from the uniqueness of a power series representation (see Theorem 2).

## SECTION 15.4. Taylor and Maclaurin Series, page 683

**Purpose.** To derive and explain Taylor series, which include those for real functions known from calculus as special cases.

### Main Content

Taylor series (1), integral formula (2) for the coefficients

Singularity, radius of convergence

Maclaurin series for  $e^z$ ,  $\cos z$ ,  $\sin z$ ,  $\cosh z$ ,  $\sinh z$ ,  $\ln(1+z)$

Theorem 2 connecting Taylor series to the last section

### Comment

The series just mentioned, with  $z = x$ , are familiar from calculus.

### SOLUTIONS TO PROBLEM SET 15.4, page 690

2.  $1 + z^3 + z^6 + z^9 + \cdots$ ,  $R = 1$ , geometric series
4.  $\cos^2 z = \frac{1}{2} + \frac{1}{2} \cos 2z = 1 - z^2 + \frac{1}{3}z^4 - \frac{2}{45}z^6 + \frac{1}{315}z^8 - \cdots$ ,  $R = \infty$
6.  $1 - (z-1) + (z-1)^2 - (z-1)^3 + \cdots$ ,  $R = 1$
8.  $\ln(1-i) - (\frac{1}{2} + \frac{1}{2}i)(z-i) - \frac{1}{4}i(z-i)^2 + (\frac{1}{12} - \frac{1}{12}i)(z-i)^3 + \cdots$ ,  $R = \sqrt{2}$ .  
This series is similar to that mentioned in the text preceding Theorem 2.
10. The series is

$$f = z + \frac{2}{1 \cdot 3} z^3 + \frac{2^2}{1 \cdot 3 \cdot 5} z^5 + \frac{2^3}{1 \cdot 3 \cdot 5 \cdot 7} z^7 + \cdots, \quad R = \infty.$$

It can be obtained in several ways. (a) Integrate the Maclaurin series of the integrand termwise and form the Cauchy product with the series of  $e^{z^2}$ . (b)  $f$  satisfies the differential equation  $f' = 2zf + 1$ . Use this, its derivatives  $f'' = 2(f + zf')$ , etc.,  $f(0) = 0$ ,  $f'(0) = 1$ , etc., and the coefficient formulas in (1). (c) Substitute

$f = \sum_{n=0}^{\infty} a_n z^n$  and  $f' = \sum_{n=0}^{\infty} n a_n z^{n-1}$  into the differential equation and compare coefficients; that is, apply the power series method (Sec. 5.1).

12.  $(z-2i) + \frac{1}{3!}(z-2i)^3 + \frac{1}{5!}(z-2i)^5 + \cdots$ ,  $R = \infty$
14.  $z - \frac{z^3}{3!3} + \frac{z^5}{5!5} - \frac{z^7}{7!7} + \cdots$ ;  $R = \infty$
16.  $z - \frac{z^5}{2!5} + \frac{z^9}{4!9} - \frac{z^{13}}{6!13} + \cdots$ ;  $R = \infty$
18. First of all, since  $\sin(w + 2\pi) = \sin w$  and  $\sin(\pi - w) = \sin w$ , we obtain all values of  $\sin w$  by letting  $w$  vary in a suitable vertical strip of width  $\pi$ , for example, in the strip  $-\pi/2 \leq u \leq \pi/2$ . Now since

$$\sin\left(\frac{\pi}{2} - iy\right) = \sin\left(\frac{\pi}{2} + iy\right) = \cosh y$$

and

$$\sin\left(-\frac{\pi}{2} - iy\right) = \sin\left(-\frac{\pi}{2} + iy\right) = -\cosh y,$$

we have to exclude a part of the boundary of that strip, so we exclude the boundary in the lower half-plane. To solve our problem we have to show that the value of the series lies in that strip. This follows from  $|z| < 1$  and

$$\begin{aligned} \left| \operatorname{Re}\left(z + \frac{1}{2} \frac{z^3}{3} + \cdots\right) \right| &\leq \left| z + \frac{1}{2} \frac{z^3}{3} + \cdots \right| \leq |z| + \frac{1}{2} \frac{|z|^3}{3} + \cdots \\ &= \arcsin |z| < \frac{\pi}{2}. \end{aligned}$$

**20. Team Project.** (a)  $(\operatorname{Ln}(1+z))' = 1 - z + z^2 - z^3 + \cdots = \frac{1}{1+z}$ .

(c) For  $y \neq 0$  the series

$$\frac{\sin iy}{iy} = \sum_{n=0}^{\infty} \frac{(-1)^n}{(2n+1)!} (iy)^{2n} = \sum_{n=0}^{\infty} \frac{1}{(2n+1)!} y^{2n}$$

has positive terms; hence its sum cannot be 0.

### SECTION 15.5. Uniform Convergence. *Optional*, page 691

**Purpose.** To explain the concept of uniform convergence. To show that power series have the advantage that they converge uniformly (exact formulation in Theorem 1). To discuss properties of general uniformly convergent series.

#### Main Content

Uniform convergence of power series (Theorem 1)

Continuous sum (Theorem 2)

Termwise integration (Theorem 3) and differentiation (Theorem 4)

Weierstrass test for uniform convergence (Theorem 5)

The test in Theorem 5 is very simple, conceptually and technically in its application.

### SOLUTIONS TO PROBLEM SET 15.5, page 697

2. This Maclaurin series of  $\sinh z$  converges uniformly on every bounded set.
4.  $|\sin^n |\pi z|| \leq 1$ ,  $1/(n(n+1)) < 1/n^2$ , and  $\sum 1/n^2$  converges. Use the Weierstrass  $M$ -test.
6.  $|z^n| \leq 1$ ,  $1/(n^2 \cosh n|z|) \leq 1/n^2$ , and  $\sum 1/n^2$  converges.
8.  $|\cos n|z|| \leq 1$  and  $\sum 1/n^2$  converges.
10. This Taylor series of  $\cosh z$  with center  $i$  converges uniformly on every bounded set.
12.  $|z - \frac{1}{2}i| \leq \frac{1}{2} - \delta$  ( $\delta > 0$ )
14.  $|z| \leq 1/\sqrt{3} - \delta$  ( $\delta > 0$ )
16. This Maclaurin series of  $\cos z$  converges uniformly on every bounded set.
18. **Team Project.** (a) Convergence follows from the comparison test (Sec. 15.1). Let  $R_n(z)$  and  $R_n^*$  be the remainders of (1) and (5), respectively. Since (5) converges, for given  $\epsilon > 0$  we can find an  $N(\epsilon)$  such that  $R_n^* < \epsilon$  for all  $n > N(\epsilon)$ . Since  $|f_m(z)| \leq M_m$  for all  $z$  in the region  $G$ , we also have  $|R_n(z)| \leq R_n^*$  and therefore  $|R_n(z)| < \epsilon$  for all  $n > N(\epsilon)$  and all  $z$  in the region  $G$ . This proves that the convergence of (1) in  $G$  is uniform.
  - (b) Since  $f'_0 + f'_1 + \cdots$  converges uniformly, we may integrate term by term, and the resulting series has the sum  $F(z)$ , the integral of the sum of that series. Therefore, the latter sum must be  $F'(z)$ .
  - (c) The converse is not true.
  - (d) Noting that this is a geometric series in powers of  $q = (1+z^2)^{-1}$ , we have  $q = |1+z^2|^{-1} < 1$ ,  $1 < |1+z^2|^2 = (1+x^2-y^2)^2 + 4x^2y^2$ , the exterior of a lemniscate. The series converges also at  $z = 0$ .

(e) We obtain (add and subtract 1)

$$\begin{aligned} x^2 \sum_{m=1}^{\infty} \frac{1}{(1+x^2)^m} &= x^2 \left( -1 + \sum_{m=0}^{\infty} \frac{1}{(1+x^2)^m} \right) \\ &= -x^2 + \frac{x^2}{1 - \frac{1}{1+x^2}} = -x^2 + 1 + x^2 = 1. \end{aligned}$$

20. We obtain

$$|B_n| = \frac{2}{L} \left| \int_0^L f(x) \sin \frac{n\pi x}{L} dx \right| < \frac{2}{L} ML$$

where  $M$  is such that  $|f(x)| < M$  on the interval of integration. Thus

$$|B_n| < K (= 2M).$$

Now when  $t \geq t_0 > 0$ ,

$$|u_n| = \left| B_n \sin \frac{n\pi x}{L} e^{-\lambda_n^2 t} \right| < K e^{-\lambda_n^2 t_0}$$

because  $\left| \sin \frac{n\pi x}{L} \right| \leq 1$  and the exponential function decreases in a monotone fashion as  $t$  increases. From this,

$$\left| \frac{\partial u_n}{\partial t} \right| = |-\lambda_n^2 u_n| = \lambda_n^2 |u_n| < \lambda_n^2 K e^{-\lambda_n^2 t_0} \quad \text{when } t \geq t_0.$$

Consider

$$\sum_{n=1}^{\infty} \lambda_n^2 K e^{-\lambda_n^2 t_0}.$$

Since  $\lambda_n = \frac{cn\pi}{L}$ , for the test ratio we have

$$\frac{\lambda_{n+1}^2 K \exp(-\lambda_{n+1}^2 t_0)}{\lambda_n^2 K \exp(-\lambda_n^2 t_0)} = \left( \frac{n+1}{n} \right)^2 \exp \left[ -(2n+1) \left( \frac{c\pi}{L} \right)^2 t_0 \right] \rightarrow 0$$

as  $n \rightarrow \infty$ , and the series converges. From this and the Weierstrass test it follows that

$$\sum \frac{\partial u_n}{\partial t} \text{ converges uniformly and, by Theorem 4, has the sum } \frac{\partial u}{\partial t}, \text{ etc.}$$

### SOLUTIONS TO CHAP. 15 REVIEW QUESTIONS AND PROBLEMS, page 698

12.  $\frac{1}{2}, \operatorname{Ln}(1+2z)$

14.  $\infty, \cos \sqrt{z}$

16.  $\infty, \sin(z-2)$

18.  $\infty, \cosh 2z$

20.  $5, \left( 1 - \frac{z-i}{3+4i} \right)^{-1}$

22.  $\operatorname{Ln} 2 + \frac{z-2}{2 \cdot 1} - \frac{(z-2)^2}{4 \cdot 2} + \frac{(z-2)^3}{8 \cdot 3} - + \dots, R=2$

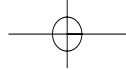

24.  $k + 3k^2(z - 1 - i) + 3^2k^3(z - 1 - i)^2 + \cdots$ ,  $k = (1 + 3i)/10$ ,  $R = \frac{1}{3}\sqrt{10}$

26.  $-1 - 2i(z - i) + 3(z - i)^2 + 4i(z - i)^3 - 5(z - i)^4 - \cdots$ ,  $R = 1$

28. The Maclaurin series of the integrand is

$$1 + \frac{1}{2!} t + \frac{1}{3!} t^2 + \frac{1}{4!} t^3 + \cdots, \quad R = \infty.$$

Termwise integration from 0 to  $z$  gives

$$z + \frac{1}{4}z^2 + \frac{1}{18}z^3 + \frac{1}{96}z^4 + \frac{1}{600}z^5 + \cdots, \quad R = \infty.$$

30.  $\frac{1}{2} - \frac{1}{2} \cos 2z = z^2 - \frac{2^3z^4}{4!} + \frac{2^5z^6}{6!} - \cdots$ ,  $R = \infty$

## CHAPTER 16 Laurent Series. Residue Integration

This is another powerful and elegant integration method that has no analog in calculus. It uses Laurent series (roughly, series of positive and negative powers of  $z$ ), more precisely, it uses just a single term of such a series (the term in  $1/(z - z_0)$ , whose coefficient is called the **residue** of the sum of the series that converges near  $z_0$ ).

### SECTION 16.1. Laurent Series, page 701

**Purpose.** To define Laurent series, to investigate their convergence in an annulus (a ring, in contrast to Taylor series, which converge in a disk), to discuss examples.

#### Major Content, Important Concepts

Laurent series

Convergence (Theorem 1)

Principal part of a Laurent series

Techniques of development (Examples 1–5)

### SOLUTIONS TO PROBLEM SET 16.1, page 707

$$2. z - \frac{1}{2z} + \frac{1}{24z^3} - + \cdots, \quad 0 < |z| < R = \infty$$

$$4. \frac{1}{z^2} \left( 1 + \frac{(2z)^2}{2!} + \frac{(2z)^4}{4!} + \frac{(2z)^6}{6!} + \cdots \right) = \frac{1}{z^2} + 2 + \frac{2}{3} z^2 + \frac{4}{45} z^4 + \cdots,$$

$$0 < |z| < R = \infty$$

6. We obtain

$$\begin{aligned} \frac{1}{z^2} e^z \frac{1}{1-z} &= \frac{1}{z^2} \sum_{m=0}^{\infty} \frac{z^m}{m!} \sum_{n=0}^{\infty} z^n \\ &= \frac{1}{z^2} \sum_{n=0}^{\infty} \left( \sum_{m=0}^n \frac{1}{m!} \right) z^n \\ &= \frac{1}{z^2} + \frac{2}{z} + \frac{5}{2} + \frac{8}{3} z + \frac{65}{24} z^2 + \cdots, \quad 0 < |z| < R = 1. \end{aligned}$$

8. Successive differentiation and use of  $\cos \frac{1}{4}\pi = \sin \frac{1}{4}\pi = 1/\sqrt{2}$  gives

$$\frac{1}{\sqrt{2}} \left[ \frac{1}{\left(z - \frac{\pi}{4}\right)^3} + \frac{1}{\left(z - \frac{\pi}{4}\right)^2} - \frac{1}{2! \left(z - \frac{\pi}{4}\right)} - \frac{1}{3!} + \frac{z - \frac{\pi}{4}}{4!} + \cdots \right],$$

$$R = \infty.$$

This can also be obtained from

$$\sin z = \sin \left[ \left(z - \frac{\pi}{4}\right) + \frac{\pi}{4} \right] = \frac{1}{\sqrt{2}} \left[ \sin \left(z - \frac{\pi}{4}\right) + \cos \left(z - \frac{\pi}{4}\right) \right]$$

and substitution of the usual series on the right.

$$10. \sum_{n=0}^{\infty} \frac{(-1)^{n+1}}{(2n)!} (z - \pi)^{2n-4} = -\frac{1}{(z - \pi)^4} + \frac{1}{2!(z - \pi)^2} - \frac{1}{4!} + \frac{1}{6!} (z - \pi)^2 - + \cdots, \quad 0 < |z| < R = \infty$$

$$12. \frac{i}{(z + i)^2} - \frac{3}{z + i} - 3i + (z + i)$$

$$14. \sum_{n=0}^{\infty} \frac{1}{(2n + 1)!z^{2n-1}} = z + \frac{1}{6z} + \frac{1}{120z^3} + \cdots, \quad 0 < |z| < R = \infty$$

16. We obtain

$$\begin{aligned} \sum_{n=0}^{\infty} \frac{(-1)^{n+1}}{2^{n+1}} (z - 1)^{n-1}, \quad 0 < |z - 1| < 2, \\ \frac{1}{1 - z^2} = \frac{1}{1 - (z - 1 + 1)^2} = \frac{-1}{(z - 1)^2 + 2(z - 1)} \\ = \frac{-1}{(z - 1)^2 \left(1 + \frac{2}{z - 1}\right)} = \sum_{n=0}^{\infty} \frac{(-1)^{n+1} 2^n}{(z - 1)^{n+2}}, \quad |z - 1| > 2 \end{aligned}$$

$$18. \sum_{n=0}^{\infty} (-1)^n (z - 1)^n, \quad 0 < |z - 1| < 1, \quad \sum_{n=0}^{\infty} \frac{(-1)^n}{(z - 1)^{n+1}}, \quad |z - 1| > 1$$

$$20. \sum_{n=0}^{\infty} \frac{a_n}{n!} (z - 1)^{n-4}, \quad a_n = \sinh 1 \quad (n \text{ even}), \quad a_n = \cosh 1 \quad (n \text{ odd}), \quad |z - 1| > 0$$

$$22. \frac{1}{z^2} = \frac{1}{[i + (z - i)]^2} = \sum_{n=0}^{\infty} \binom{-2}{n} \frac{(z - i)^n}{i^{n+2}}, \quad |z - i| < 1,$$

$$\frac{1}{z^2} = \frac{1}{(z - i)^2 \left(1 + \frac{i}{z - i}\right)^2} = \sum_{n=0}^{\infty} \binom{-2}{n} \frac{i^n}{(z - i)^{n+2}}, \quad |z - i| > 1$$

24. **Team Project.** (a) Let  $\sum_{-\infty}^{\infty} a_n(z - z_0)^n$  and  $\sum_{-\infty}^{\infty} c_n(z - z_0)^n$  be two Laurent series of the same function  $f(z)$  in the same annulus. We multiply both series by  $(z - z_0)^{-k-1}$  and integrate along a circle with center at  $z_0$  in the interior of the annulus. Since the series converge uniformly, we may integrate term by term. This yields  $2\pi i a_k = 2\pi i c_k$ . Thus,  $a_k = c_k$  for all  $k = 0, \pm 1, \cdots$ .

(b) No, because  $\tan(1/z)$  is singular at  $1/z = \pm\pi/2, \pm 3\pi/2, \cdots$ , hence at  $z = \pm 2/\pi, \pm 2/3\pi, \cdots$ , which accumulate at 0.

(c) These series are obtained by termwise integration of the integrand. The second function is  $\text{Si}(z)/z^3$ , where  $\text{Si}(z)$  is the sine integral [see (40) in App. A.31]. *Answer:*

$$\begin{aligned} \frac{1}{z} + \frac{1}{2!2} + \frac{z}{3!3} + \frac{z^2}{4!4} + \cdots, \\ \frac{1}{z^2} - \frac{1}{3!3} + \frac{z^2}{5!5} - + \cdots. \end{aligned}$$



**SECTION 16.2. Singularities and Zeros. Infinity, page 707**

**Purpose.** *Singularities* just appeared in connection with the convergence of Taylor and Laurent series in the last sections, and since we now have the instrument for their classification and discussion (i.e., Laurent series), this seems the right time for doing so. We also consider *zeros*, whose discussion is somewhat related.

**Main Content, Important Concepts**

Principal part of a Laurent series convergent near a singularity

Pole, behavior (Theorem 1)

Isolated essential singularity, behavior (Theorem 2)

Zeros are isolated (Theorem 3)

Relation between poles and zeros (Theorem 4)

Point  $\infty$ , extended complex plane, behavior at  $\infty$

Riemann sphere

**SOLUTIONS TO PROBLEM SET 16.2, page 711**

2. 0 (pole of second order),  $\infty$  (simple pole)
4. 1 (essential singularity),  $\infty$  (pole of third order)
6.  $\pi/4 \pm n\pi$  (simple poles). These are the points where the sine and cosine curves intersect. They have a different tangent there, hence their difference  $\cos z - \sin z$  cannot have a zero derivative at those points; accordingly, those zeros are simple and give simple poles of the given function. To make sure that no further zeros of  $\cos z - \sin z$  exist, one must calculate

$$\cos z - \sin z = \left(\frac{1}{2} - \frac{1}{2i}\right)e^{iz} + \left(\frac{1}{2} + \frac{1}{2i}\right)e^{-iz} = 0,$$

and by simplification,

$$e^{2iz} = i, \quad z = \frac{\pi}{4} \pm n\pi, \quad n = 0, 1, \dots,$$

so that we get no further solutions beyond those found by inspecting those two curves.

8. 0 (third-order pole). This problem emphasizes that the order of a pole is determined by the highest negative power, regardless of other terms (which may or may not be present).
10. 1,  $\infty$  (essential singularities),  $\pm 2n\pi i$  ( $n = 0, 1, \dots$ , simple poles)
12. For  $|z|$  small enough we have  $|1 + z| > 1/\sqrt{2}$ ,  $|1 - z| > 1/\sqrt{2}$ ; hence

$$|1 - z^2| = |1 + z| |1 - z| > 1/2$$

and

$$\left| \frac{1}{z^3} - \frac{1}{z} \right| = \frac{1}{|z|^3} \left| 1 - z^2 \right| > \frac{1}{2|z|^3} \rightarrow \infty \quad \text{as} \quad |z| \rightarrow 0.$$

This motivates the proof.

To prove the theorem, let  $f(z)$  have a pole of  $m$ th order at some point  $z = z_0$ . Then

$$\begin{aligned} f(z) &= \frac{b_m}{(z - z_0)^m} + \frac{b_{m-1}}{(z - z_0)^{m-1}} + \cdots \\ &= \frac{b_m}{(z - z_0)^m} \left[ 1 + \frac{b_{m-1}}{b_m} (z - z_0) + \cdots \right], \quad b_m \neq 0. \end{aligned}$$

For given  $M > 0$ , no matter how large, we can find a  $\delta > 0$  so small that

$$\frac{|b_m|}{\delta^m} > 2M \quad \text{and} \quad \left| \left[ 1 + \frac{b_{m-1}}{b_m} (z - z_0) + \cdots \right] \right| > \frac{1}{2}$$

for all  $|z - z_0| < \delta$ . Then

$$|f(z)| > \frac{|b_m|}{\delta^m} \frac{1}{2} > M.$$

Hence  $|f(z)| \rightarrow \infty$  as  $z \rightarrow z_0$ .

18.  $z^4 = 16$  has the solutions  $\pm 2$  and  $\pm 2i$ . Because of the other exponent 4 this gives zeros of fourth order.
16.  $(\frac{1}{2} \pm n)\pi i$  (second order) because

$$\cosh z = \frac{1}{2}(e^z + e^{-z}) = 0; \quad \text{hence} \quad e^{2z} = -1$$

and this implies

$$2z = \text{Ln}(-1) \pm 2n\pi i = (1 \pm 2n)\pi i$$

so that  $z$  has the values given at the beginning.

18.  $\pm 1$  (second order),  $(\pm 1 \pm i)\sqrt{n\pi}$  (simple) because

$$e^{z^2} = 1, \quad z^2 = \text{Ln} 1 \pm 2n\pi i = \pm 2n\pi i;$$

hence

$$z = \sqrt{\pm 2n\pi i} = \pm \frac{1 \pm i}{\sqrt{2}} \sqrt{2n\pi}.$$

20.  $\frac{1}{2}\pi \pm 2n\pi$  ( $n = 0, 1, \dots$ ), sixth order, since

$$(\sin z - 1)' = \cos z = 0$$

at those points.

22.  $e^z - e^{2z} = e^z(1 - e^z) = 0$ ,  $e^z = 1$ ,  $z = \text{Ln} 1 \pm 2n\pi i = \pm 2n\pi i$ . These zeros are simple because  $(e^z - 1)' = e^z \neq 0$  for all  $z$ .
24. **Team Project.** (a)  $f(z) = (z - z_0)^n g(z)$  gives

$$f'(z) = n(z - z_0)^{n-1} g(z) + (z - z_0)^n g'(z)$$

which implies the assertion because  $g(z_0) \neq 0$ .

(b)  $f(z)$  as in (a) implies  $1/f(z) = (z - z_0)^{-n} h(z)$ , where  $h(z) = 1/g(z)$  is analytic at  $z_0$  because  $g(z_0) \neq 0$ .

(c)  $f(z) - k = 0$  at those points. Apply Theorem 3.

(d)  $f_1(z) - f_2(z)$  is analytic in  $D$  and zero at each  $z_n$ . Hence its zeros are not isolated because that sequence converges. Thus it must be constant, since otherwise it would contradict Theorem 3. And that constant must be zero because it is zero at those points. Thus  $f_1(z)$  and  $f_2(z)$  are identical in  $D$ .

**SECTION 16.3. Residue Integration Method, page 712**

**Purpose.** To explain and apply this most elegant integration method.

**Main Content, Important Concepts**

Formulas for the residues at poles (3)–(5)

Residue theorem (several singularities inside the contour)

**Comment**

The extension from the case of a single singularity to several singularities (residue theorem) is immediate.

**SOLUTIONS TO PROBLEM SET 16.3, page 717**

2.  $-8$

4. The residue at  $z = 0$  is 0 because  $(\cos z)/z^6$  contains only even powers.

6.  $z^2 - z = z(z - 1)$ , simple poles at 0 and 1, and (4) gives

$$\operatorname{Res}_{z=0} \frac{z^2 + 1}{z^2 - z} = \frac{z^2 + 1}{2z - 1} \Big|_{z=0} = -1, \quad \operatorname{Res}_{z=1} \frac{z^2 + 1}{z^2 - z} = \frac{z^2 + 1}{2z - 1} \Big|_{z=1} = 2.$$

8.  $(-1)^{n+1}$  (at  $z = (2n + 1)\pi/2$ ) because the simple zeros of  $\cos z$  at the points  $z = z_n = (2n + 1)\pi/2$  give simple poles of  $\sec z$ , and (4) yields

$$\frac{1}{(\cos z)'} \Big|_{z_n} = \frac{-1}{\sin z} \Big|_{z_n} = (-1)^{n+1}.$$

10. Simple poles at  $\pm 1$  and  $\pm i$ . In (4) we have  $p(z)/q'(z) = 1/12z^3$ . Hence the values of the residues are  $\pm 1/12$  and  $\pm i/12$ , respectively.

12. Simple poles at  $\pm 1$  and  $\pm i$ , residues  $\pm \frac{1}{4}$  and  $\mp \frac{1}{4}i$ , respectively.

14. Third-order pole at  $z = 0$ . No further singularities in the finite plane. Multiplying the Maclaurin series of  $\sin \pi z$  by  $1/z^4$  gives the Laurent series

$$\frac{1}{z^4} \left( \pi z - \frac{1}{3!} (\pi z)^3 + \dots \right) = \frac{\pi}{z^3} - \frac{1}{6z} \pi^3 + \dots.$$

Hence the residue is  $-\pi^3/6$ . *Answer:*  $-\pi^4/3$ .

16.  $\sinh z = 0$  at  $0, \pm \pi i, \pm 2\pi i, \dots$ . Hence  $\sinh \frac{1}{2}\pi z = 0$  at  $0$  (inside  $C$ ),  $\pm 2i, \pm 4i, \dots$  (all outside  $C$ ). These are simple poles, and (4) gives the residue

$$\operatorname{Res}_{z=0} \frac{1}{\sinh \frac{1}{2}\pi z} = \frac{1}{\frac{1}{2}\pi \cosh 0} = \frac{2}{\pi}.$$

Hence the *answer* is  $2\pi i \cdot (2/\pi) = 4i$ .

18. Simple poles at  $z_0 = \pm \frac{1}{2}$  and  $\pm \frac{3}{2}$  inside  $C$  and infinitely many others outside  $C$ . Formula (4) gives the residues  $(\sin z_0)/(-\pi \sin z_0) = -1/\pi$ . Hence the *answer* is  $2\pi i \cdot 4 \cdot (-1/\pi) = -8i$ .

20. Simple pole at  $0$ , residue [by (4)]

$$\frac{\cosh z}{(\sinh z)'} = 1.$$

*Answer:*  $2\pi i$ .

22. Simple poles at 0 (inside  $C$ ) and  $3i$  (outside  $C$ ), and (3) gives

$$\operatorname{Res}_{z=0} \frac{\cosh z}{z^2 - 3iz} = \frac{\cosh z}{z - 3i} \Big|_{z=0} = \frac{i}{3}.$$

Answer:  $-2\pi/3$ .

24. Simple poles at  $z_0 = -i/2, i/2$  (inside  $C$ ) and 2 (outside  $C$ ), and (4) gives the residues

$$\begin{aligned} \operatorname{Res}_{z=z_0} \frac{1 - 4z + 6z^2}{(z^2 + \frac{1}{4})(2 - z)} &= \frac{1 - 4z + 6z^2}{[(z^2 + \frac{1}{4})(2 - z)]'} \Big|_{z_0} \\ &= \frac{1 - 4z_0 + 6z_0^2}{-3z_0^2 + 4z_0 - \frac{1}{4}} = -1, -1. \end{aligned}$$

Answer:  $2\pi i(-1 - 1) = -4\pi i$ .

### SECTION 16.4. Residue Integration of Real Integrals, page 718

**Purpose 1.** To show that certain classes of *real* integrals over finite or infinite intervals of integration can also be evaluated by residue integration.

#### Comment on Content

Since residue integration requires a closed path, one must have methods for producing such a path. We see that for the finite intervals in the text, this is done by (2), perhaps preceded by a translation and change of scale if another interval is given. (This is not shown in the text.) In the case of an infinite interval, we start from a finite one, close it by some curve in complex (here, a semicircle; Fig. 371), blow it up, and make assumptions on the integrand such that we can prove (once and for all) that the value of the integral over the complex curve added goes to zero.

**Purpose 2.** Extension of the second of the two methods just mentioned to integrals of practical interest in connection with Fourier integral representations (Sec. 11.7) and to discuss the case of singularities on the real axis.

#### Main Content

Integrals involving  $\cos$  and  $\sin$  (1), their transformation (2)

Improper integral (4), Cauchy principal value

Fourier integrals

Poles on the real axis (Theorem 1), Cauchy principal value

### SOLUTIONS TO PROBLEM SET 16.4, page 725

2. This integral is of the form

$$\begin{aligned} \int_0^\pi \frac{d\theta}{a + b \cos \theta} &= \frac{1}{2} \int_0^{2\pi} \frac{d\theta}{a + b \cos \theta} \\ &= \frac{1}{2} \oint_C \frac{dz}{iz[a + \frac{1}{2}b(z + 1/z)]} \\ &= \frac{1}{ib} \oint_C \frac{dz}{z^2 + 2az/b + 1} \quad (a > b > 0). \end{aligned}$$

The zeros of the denominator,

$$z_1 = -\frac{a}{b} + K, \quad z_2 = -\frac{a}{b} - K, \quad K^2 = \frac{a^2}{b^2} - 1$$

give poles at  $z_1$  (inside the unit circle  $C$  because  $a > b > 0$ ) and  $z_2$  (outside  $C$ ) with the residue

$$\operatorname{Res}_{z=z_1} \frac{1}{z^2 + 2az/b + 1} = \frac{1}{z - z_2} \Big|_{z_1} = \frac{1}{2K}$$

and the integral from 0 to  $\pi$  equals

$$2\pi i \cdot \frac{1}{2ibK} = \frac{\pi}{bK} = \frac{\pi}{\sqrt{a^2 - b^2}}$$

and  $2\pi/bK$  if we integrate from 0 to  $2\pi$ . In our case  $a = 2$ ,  $b = 1$  and the answer is  $\pi/\sqrt{3}$ .

4. This integral is of the form (similar to Prob. 2)

$$\begin{aligned} \int_0^{2\pi} \frac{d\theta}{a - b \sin \theta} &= \oint_C \frac{dz}{iz[a - (b/2i)(z - 1/z)]} \\ &= \frac{2}{-b} \oint_C \frac{dz}{z^2 - (2ai/b)z - 1} \\ &= \frac{-2}{b} \oint_C \frac{dz}{(z - z_1)(z - z_2)} \quad (a > b > 0) \end{aligned}$$

where the zeros of the denominator (the poles of the integrand) are

$$z_1 = \frac{ai}{b} + iK, \quad z_2 = \frac{ai}{b} - iK, \quad K^2 = \frac{a^2}{b^2} - 1$$

and from (3), Sec. 16.3, we obtain the residue of the pole inside the unit circle

$$\operatorname{Res}_{z=z_2} \frac{1}{(z - z_1)(z - z_2)} = \frac{1}{z_2 - z_1} = -\frac{1}{2iK}.$$

Hence the integral equals

$$2\pi i(-2/b)(-1/(2Ki)) = 2\pi/(bK) = 2\pi/\sqrt{a^2 - b^2}.$$

In our case,  $a = 8$ ,  $b = 2$  gives the answer  $2\pi/\sqrt{60} = \pi/\sqrt{15}$ .

All this also follows directly from Prob. 2 by using  $-\sin \theta = \cos \theta^*$ , where  $\theta^* = \theta + \frac{1}{2}\pi$ , and noting that the integrand is periodic with  $2\pi$ .

6. The integral equals

$$\oint_C \frac{-\frac{1}{4}(z - 1/z)^2}{i[5z - 2(z^2 + 1)]} dz = \frac{-1/4}{-2i} \oint_C \frac{(z^2 - 1)^2}{z^2[z^2 - 5z/2 + 1]} dz.$$

From (5\*), Sec. 16.3, we obtain for the integrand of the last integral (without the factor in front of it) at  $z = 0$  (second-order pole) the residue

$$\left[ \frac{(z^2 - 1)^2}{z^2 - 5z/2 + 1} \right]'_{z=0} = \frac{5}{2}$$

by straightforward differentiation. Also,

$$z^2 - 5z/2 + 1 = (z - 2)(z - \frac{1}{2})$$

and for the simple pole at  $z = 1/2$  (inside the unit circle) we get the residue

$$\frac{(z^2 - 1)^2}{z^2(z - 2)} \Big|_{z=1/2} = \frac{9/16}{(1/4)(-3/2)} = -\frac{3}{2}.$$

In front of the integral,  $(-1/4)/(-2i) = -i/8$ . Together,

$$2\pi i(-i/8)(5/2 - 3/2) = \pi/4.$$

8. The integral equals

$$\frac{1}{i} \oint_C \frac{1 + 2(z + z^{-1})}{z[17 - 4(z + z^{-1})]} dz = \frac{1}{-4i} \oint_C \frac{2z^2 + z + 2}{z(z - z_1)(z - z_2)} dz$$

where  $z_1 = 1/4$  (inside the unit circle) and  $z_2 = 4$  (outside) give simple poles. The residue for the last integrand (without the factor  $1/(-4i)$ ) at  $z = 0$  is  $2/(z_1 z_2) = 2$ , and at  $z = 1/4$  it is

$$\frac{2/16 + 1/4 + 2}{(1/4)(1/4 - 4)} = -\frac{38}{15}.$$

This gives the *answer*

$$\frac{2\pi i}{-4i} \left( 2 - \frac{38}{15} \right) = \frac{4\pi}{15}.$$

10. *Answer* 0, because the integrand is an odd function. Or by calculating the residues  $\mp i/4$  at the two simple poles at  $(1 + i)/\sqrt{2}$  and  $(-1 + i)/\sqrt{2}$ , respectively, in the upper half-plane.
12. Second-order pole at  $z_1 = 1 + 2i$  in the upper half-plane (and at  $z_2 = 1 - 2i$  in the lower) with residue

$$\left[ \frac{1}{(z - 1 + 2i)^2} \right]'_{z=z_1} = \frac{-2}{(z_1 - z_2)^3} = \frac{-2}{(4i)^3} = \frac{1}{32i}.$$

*Answer:*  $2\pi i(1/(32i)) = \pi/16$ .

14. Simple poles at  $z_1 = (2 + 2i)/\sqrt{2}$  and  $z_2 = (-2 + 2i)/\sqrt{2}$  in the upper half-plane (and at  $(\pm 2 - 2i)/\sqrt{2}$  in the lower half-plane). From (4) in Sec. 16.3 we obtain the residues

$$1/(4z_1^3) = (-1 - i)/(32\sqrt{2}), \quad 1/4z_2^3 = (1 - i)/(32\sqrt{2}).$$

*Answer:*  $\pi(8\sqrt{2})$ .

16. Simple poles at  $i$  and  $3i$  with residues  $-i/16$  and  $i/48$ , respectively. *Answer:*  $\pi/12$ .
18. Denote the integrand by  $f(x)$ . The complex function  $f(z)$  has simple poles at  $z_1 = e^{\pi i/4}$  and  $z_2 = e^{3\pi i/4}$  in the upper half-plane (and two further ones in the lower half-plane) with residues

$$\frac{1 + i}{2\sqrt{2}(-1 + i)} = -\frac{i}{\sqrt{8}} \quad \text{and} \quad \frac{1 - i}{2\sqrt{2}(1 + i)} = -\frac{i}{\sqrt{8}}$$

respectively, as obtained from (4) in Sec. 16.3. Hence the *answer* is  $(-i/\sqrt{2})2\pi i = \pi\sqrt{2}$ .

20. From  $z^4 + 1 = 0$  we see that we have four simple poles, at  $z_1 = (1 + i)/\sqrt{2}$  and  $z_2 = (-1 + i)/\sqrt{2}$  in the upper half-plane (and at  $(\pm 1 - i)/\sqrt{2}$  in the lower). From (4), Sec. 16.3, we find that the residues of  $e^{iz}/(z^4 + 1)$ , as presently needed, are

$$\frac{e^{iz_1}}{4z_1^3} = \frac{e^{-1/\sqrt{2}}(c + is)}{4(-2 + 2i)/2\sqrt{2}} = \frac{e^{-1/\sqrt{2}}}{8\sqrt{2}} (-2 - 2i)(c + is),$$

where  $c + is = \cos(1/\sqrt{2}) + i \sin(1/\sqrt{2})$ , and

$$\frac{e^{iz_2}}{4z_2^3} = \frac{e^{-1/\sqrt{2}}(c - is)}{4(2 + 2i)/2\sqrt{2}} = \frac{e^{-1/\sqrt{2}}}{8\sqrt{2}} (2 - 2i)(c - is).$$

We now take the sum of the imaginary parts of these two residues and multiply it by  $-2\pi$ , as indicated in the first formula in (10); this then gives the *answer*

$$\pi \frac{e^{-1/\sqrt{2}}}{\sqrt{2}} \left( \cos \frac{1}{\sqrt{2}} + \sin \frac{1}{\sqrt{2}} \right) = 1.544.$$

22.  $z^4 + 5z^2 + 4 = (z^2 + 1)(z^2 + 4)$  shows that we have two simple poles at  $z_1 = i$  and  $z_2 = 2i$  in the upper half-plane (and two at  $-i$  and  $-2i$  in the lower). By (4), Sec. 16.3, the sum of the residues of  $e^{4iz}/(z^4 + 5z^2 + 4)$  at  $z_1$  and  $z_2$  is

$$\frac{e^{-4}}{4i^3 + 10i} + \frac{e^{-8}}{4(2i)^3 + 20i} = -\frac{i}{6} e^{-4} + \frac{i}{12} e^{-8}.$$

From the first formula in (10) we thus obtain the *answer*

$$\pi(2e^{-4} - e^{-8})/6.$$

24. Simple poles at  $z_0 = \pm 1, i$  (and  $-i$  outside, in the lower half-plane), with residue  $z_0^2/(4z_0^3) = 1/(4z_0)$ , as obtained from (4) in Sec. 16.3. Hence the *answer* is

$$2\pi i \left( -\frac{i}{4} \right) + \pi i \left( -\frac{1}{4} + \frac{1}{4} \right) = \frac{1}{2} \pi.$$

26. The integrand is  $p/q$ , where  $p = 1$  and  $q(x) = x^4 + 3x^2 - 4$ ; hence

$$q(z) = z^4 + 3z^2 - 4.$$

In (4) in Sec. 16.3 we need the derivative  $q'(z) = 4z^3 + 6z$ . Simple poles are at  $2i$ ,  $-1$ , and  $1$  (and  $-2i$ , not needed), with residues  $i/20$ ,  $-1/10$ , and  $1/10$ , respectively. Hence the value of the integral is

$$2\pi i \cdot \frac{i}{20} + \pi i \left( -\frac{1}{10} + \frac{1}{10} \right) = -\frac{\pi}{10}.$$

A graph of the integrand makes it plausible that the integral should have a negative value.

28. **Team Project.** (b) The integral of  $e^{-z^2}$  around  $C$  is zero. Writing it as the sum of four integrals over the four segments of  $C$ , we have

$$\int_{-a}^a e^{-x^2} dx + ie^{-a^2} \int_0^b e^{y^2 - 2ayi} dy + e^{b^2} \int_a^{-a} e^{-x^2 - 2ibx} dx + ie^{-a^2} \int_b^0 e^{y^2 + 2ayi} dy = 0.$$

Let  $a \rightarrow \infty$ . Then the terms having the factor  $e^{-a^2}$  approach zero. Taking the real part of the third integral, we thus obtain

$$-\int_{-\infty}^{\infty} e^{-x^2} \cos 2bx \, dx = 2 \int_0^{\infty} e^{-x^2} \cos 2bx \, dx = e^{-b^2} \int_{-\infty}^{\infty} e^{-x^2} \, dx = e^{-b^2} \sqrt{\pi}.$$

Answer:  $\frac{1}{2}e^{-b^2}\sqrt{\pi}$ .

(c) Use the fact that the integrands are odd.

30. Let  $q(z) = (z - a_1)(z - a_2) \cdots (z - a_k)$ . Use (4) in Sec. 16.3 to form the sum of the residues  $1/q'(a_1) + \cdots + 1/q'(a_k)$  and show that this sum is 0; here  $k > 1$ .

### SOLUTIONS TO CHAP. 16 REVIEW QUESTIONS AND PROBLEMS, page 726

18. Third-order pole at  $z = 0$  with residue best obtained from the series

$$\frac{\sin 2z}{z^4} = \sum_{n=0}^{\infty} \frac{(-1)^n 2^{2n+1}}{(2n+1)!} z^{2n-3}$$

namely,  $1/z$  has the coefficient

$$\operatorname{Res}_{z=0} z^{-4} \sin 2z = -\frac{2^3}{3!}.$$

Answer:  $2\pi i(-8/6) = -8\pi i/3$ .

20. Simple poles at  $-i$  and  $2i$ , both inside  $C$ , with residues  $2i/3$  and  $i/3$ , respectively, as obtained from (4), Sec. 16.3, or from the partial fraction representation

$$\frac{2i/3}{z+i} + \frac{i/3}{z-2i}$$

of the integrand. Answer:  $2\pi i(2i/3 + i/3) = -2\pi$ .

22. Simple poles at  $-\pi/2$  inside  $C$  and others outside  $C$ , and (4), Sec. 16.3, gives the residue

$$\operatorname{Res}_{z=-\pi/2} \frac{4z^3 + 7z}{\cos z} = -\frac{4(-\pi/2)^3 + 7(-\pi/2)}{\sin(-\pi/2)} = -\frac{1}{2}\pi^3 - \frac{7}{2}\pi.$$

Answer:  $-i(\pi^3 + 7\pi) = -\pi^2(\pi^2 + 7)i = -166.5i$ .

24. Simple poles at  $z_0 = -\frac{1}{2}, \frac{1}{2}$  with residues (by (4) in Sec. 16.3)

$$\frac{z_0^2 \sin z_0}{8z_0} = \frac{1}{8}z_0 \sin z_0 = \frac{1}{16} \sin \frac{1}{2}.$$

Answer:  $2\pi i \cdot 2 \cdot \frac{1}{16} \sin \frac{1}{2} = \frac{1}{4}\pi i \sin \frac{1}{2} = 0.3765i$ .

26. Simple poles at 0 (inside  $C$ ) and 2 (outside  $C$ ), and (3), Sec. 16.3, gives the residue

$$\operatorname{Res}_{z=0} \frac{z^2 + 1}{z^2 - 2z} = \frac{z^2 + 1}{z - 2} \Big|_{z=0} = -\frac{1}{2}.$$

Answer:  $2\pi i(-1/2) = -\pi i$ .

28.  $z^3 - 9z = z(z+3)(z-3) = 0$  at  $z = -3, 0, 3$  gives simple poles, all three inside  $C$ :  $|z| = 4$ . From (4), Sec. 16.3, we get the residue

$$\operatorname{Res}_{z=-3} \frac{15z + 9}{z^3 - 9z} = \frac{15z + 9}{3z^2 - 9} \Big|_{z=-3} = \frac{-36}{18} = -2$$



and similarly, at 0 the residue  $9/(-9) = -1$  and at 3 the residue  $54/18 = 3$ . Since all three poles lie inside  $C$ , by the residue theorem we have to take the sum of all three residues, which is zero. *Answer:* 0.

30.  $\pi\sqrt{k^2 - 1}$ , a special case of the class of integrals in the answer to Prob. 2 of Problem Set 16.4 with  $a = k$  and  $b = 1$ .
32. The integral equals

$$\oint_C \frac{(z - 1/z)/(2i)}{iz[3 + \frac{1}{2}(z + 1/z)]} dz = -\oint_C \frac{z^2 - 1}{z[z^2 + 6z + 1]} dz.$$

At the simple pole at  $z = 0$  the residue is  $-1$ . At the simple pole at  $-3 + \sqrt{8}$  (inside the unit circle) the residue is

$$\frac{(-3 + \sqrt{8})^2 - 1}{3(-3 + \sqrt{8})^2 + 12(-3 + \sqrt{8}) + 1} = 1.$$

*Answer:* 0. Simpler: integrate from  $-\pi$  to  $\pi$  and note that the integrand is odd.

34. Second-order poles at  $z = i$  in the upper half-plane (and at  $-i$  in the lower half-plane) with residue [by (5), Sec. 16.3]

$$[(z + i)^{-2}]'_{z=i} = -i/4.$$

*Answer:*  $\frac{1}{2} \cdot 2\pi i(-i/4) = \pi/4$ .

36. Set  $x = t/\sqrt{2}$ . Then  $dx = dt/\sqrt{2}$  and

$$\frac{\pi}{2} = \int_0^\infty \frac{1 + 2x^2}{1 + 4x^4} dx = \frac{1}{\sqrt{2}} \int_0^\infty \frac{1 + t^2}{1 + t^4} dt = \frac{1}{2\sqrt{2}} \int_{-\infty}^\infty \frac{1 + t^2}{1 + t^4} dt.$$

Multiply by  $2\sqrt{2}$  to get  $\pi\sqrt{2}$  as the value of the integral on the right.

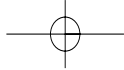

## CHAPTER 17 Conformal Mapping

This is a new chapter. It collects and extends the material on conformal mapping contained in Chap. 12 of the previous edition.

### SECTION 17.1. Geometry of Analytic Functions: Conformal Mapping, page 729

**Purpose.** To show conformality (preservation of angles in size and sense) of the mapping by an analytic function  $w = f(z)$ ; exceptional are points with  $f'(z) = 0$ .

#### Main Content, Important Concepts

Concept of mapping. Surjective, injective, bijective

Conformal mapping (Theorem 1)

Magnification, Jacobian

Examples. Joukowski airfoil

#### Comment on the Proof of Theorem 1

The crucial point is to show that  $w = f(z)$  rotates all straight lines (hence all tangents) passing through a point  $z_0$  through the same angle  $\alpha = \arg f'(z_0)$ , but this follows from (3). This in a nutshell is the proof, once the stage has been set.

### SOLUTIONS TO PROBLEM SET 17.1, page 733

2. By conformality

4.  $u = x^2 - y^2$ ,  $v = 2xy$ ,  $y^2 = v^2/(4x^2)$ ,  $x^2 = v^2/(4y^2)$ ; hence for  $x = 1, 2, 3, 4$  we obtain

$$u = x^2 - v^2/(4x^2) = 1 - v^2/4, \quad 4 - v^2/16, \quad 9 - v^2/36, \quad 16 - v^2/64$$

and for  $y = 1, 2, 3, 4$ ,

$$u = v^2/(4y^2) - y^2 = v^2/4 - 1, \quad v^2/16 - 4, \quad v^2/36 - 9, \quad v^2/64 - 16.$$

6.  $w = 1/z$  is called **reflection in the unit circle**. The answer is

$$|w| = 3, 2, 1, 1/2, 1/3$$

and

$$\text{Arg } w = 0, \mp \pi/4, \mp \pi/2, \mp 3\pi/4, \mp \pi.$$

We see that the unit circle is mapped onto itself, but only 1 and  $-1$  are mapped onto themselves.  $e^{-i\theta}$  is mapped onto  $e^{-i\theta}$ , the complex conjugate, for example,  $i$  onto  $-i$ .

8. On the line  $x = 1$  we have  $z = 1 + iy$ ,  $w = u + iv = 1/z = (1 - iy)/(1 + y^2)$ , so that  $v = -y/(1 + y^2)$  and, furthermore,

$$u = \frac{1}{1 + y^2}, \quad u(1 - u) = \frac{1}{1 + y^2} \left(1 - \frac{1}{1 + y^2}\right) = \frac{y^2}{(1 + y^2)^2} = v^2.$$

Having obtained a relation between  $u$  and  $v$ , we have solved the problem. We now have  $u^2 - u + v^2 = 0$ ,  $(u - \frac{1}{2})^2 + v^2 = \frac{1}{4}$  and by taking roots  $|w - \frac{1}{2}| = \frac{1}{2}$ , a circle through 0 and 1 whose interior is the image of  $x > 1$ .

10. The lower half-plane



12. Annulus  $1/e < |w| < e$  cut along the negative real axis
14. Whole  $w$ -plane except  $w = 0$
16. **CAS Experiment.** Orthogonality is a consequence of conformality because in the  $w$ -plane,  $u = \text{const}$  and  $v = \text{const}$  are orthogonal. We obtain
- (a)  $u = x^4 - 6x^2y^2 + y^4, \quad v = 4x^3y - 4xy^3$
- (b)  $u = x/(x^2 + y^2), \quad v = -y/(x^2 + y^2)$
- (c)  $u = (x^2 - y^2)/(x^2 + y^2)^2, \quad v = -2xy/(x^2 + y^2)^2$
- (d)  $u = 2x/((1 - y)^2 + x^2), \quad v = (1 - x^2 - y^2)/((1 - y)^2 + x^2)$
18.  $2z - 2z^{-3} = 0, z^4 = 1$ , hence  $\pm 1, \pm i$ .
20.  $(\cosh 2z)' = 2 \sinh 2z = 0$  at  $z = 0, \pm \pi i/2, \pm \pi i, \dots$
22.  $(5z^4 - 80) \exp(z^5 - 80z) = 0, z^4 = 16, z = \pm 2, \pm 2i$
24.  $M = |z| = 1$  on the unit circle,  $J = |z|^2$
26.  $M = 3|z|^2 = 1$  on the circle  $|z| = 1/\sqrt{3}$ ,  $J = 9|z|^4$
28.  $w' = -1/z^2, M = |w'| = 1/|z|^2 = 1$  on the unit circle,  $J = 1/|z|^4$
30. By the Taylor series, since the first few derivatives vanish at  $z_0$ ,

$$f(z) = f(z_0) + (z - z_0)^k g(z), \quad g(z_0) \neq 0, \text{ since } f^{(k)}(z_0) \neq 0.$$

Hence

$$\arg [f(z) - f(z_0)] = k \arg (z - z_0) + \arg g(z).$$

Now the angle  $\alpha$  from the  $x$ -axis to the tangent of a smooth curve  $C$  at  $z_0$  is

$$\alpha = \lim \arg (z - z_0) \quad (z \rightarrow z_0 \text{ along } C).$$

Similarly for the angle  $\beta$  of the tangent to the image at  $f(z_0)$ :

$$\beta = \lim \arg [f(z) - f(z_0)] = k\alpha + \lim \arg g(z) = k\alpha + \arg g(z_0).$$

Note that  $\gamma = \arg g(z_0)$  is defined since  $g(z_0) \neq 0$ . Hence the angle  $\beta_2 - \beta_1$  between the tangents of the images of two curves at  $f(z_0)$  is

$$\beta_2 - \beta_1 = k\alpha_2 + \gamma - (k\alpha_1 + \gamma) = k(\alpha_2 - \alpha_1),$$

as asserted.

## SECTION 17.2. Linear Fractional Transformations, page 734

**Purpose.** Systematic discussion of linear fractional transformations (Möbius transformations), which owe their importance to a number of interesting properties shown in this section and the next one.

### Main Content

Definition (1)

Special cases (3), Example 1

Images of circles and straight lines (Theorem 1)

One-to-one mapping of the extended complex plane

Inverse mapping (4)

Fixed points

**SOLUTIONS TO PROBLEM SET 17.2, page 737**

2. This follows by direct calculation and simplification.
4.  $z = \frac{w - i}{3iz + 4}$
6.  $z = \frac{-iw - i}{-w + 1}$
8.  $z = 0, \pm 1/3, \pm i/3$
10. None. Translations have no fixed points.
12.  $\pm i$
14.  $z(z - 1) = 3z + 2, z^2 - 4z - 2 = 0, z = 2 \pm \sqrt{4 + 2}$
16. The equation with solutions 0 and 1 (the desired fixed points) is  $z(z - 1) = 0$ , thus  $z^2 - z = 0$ . Comparing this with the fixed-point equation (5),

$$cz^2 - (a - d)z - b = 0,$$

we see that we must have  $c \neq 0$ ; so we can choose  $c = 1$ . Also,  $a - d = 1$  and  $b = 0$ . This gives  $a = 1 + d$  and the answer

$$w = \frac{(1 + d)z}{z + d},$$

where the student now may choose some  $d$ , except for  $d = 0$ , which would give the identity mapping; so it is quite interesting that  $d$  may be as close to zero as we please, but not zero.

18. By comparing  $z = 0$  with the fixed-point equation (5), as in Prob. 16, we get  $b = 0$ ,  $a = d$ . and

$$w = \frac{az}{cz + a}.$$

20. We get a fixed-point equation (5) without solutions if and only if we choose  $c = 0$ ,  $a - d = 0$ , and  $b \neq 0$ . This gives a translation

$$w = (az + b)/a = z + b/a \quad (a \neq 0),$$

as expected.

**SECTION 17.3. Special Linear Fractional Transformations, page 737**

**Purpose.** Continued discussion to show that linear fractional transformations map “standard domains” conformally onto each other.

**Main Content**

Determination by three points and their images  
 Mappings of standard domains (disks, half-planes)  
 Angular regions

**SOLUTIONS TO PROBLEM SET 17.3, page 741**

2. The inverse is

$$z = \frac{w + i}{iw + 1} = \frac{u + iv + i}{1 - v + iu} = \frac{(u + iv + i)(1 - v - iu)}{(1 - v)^2 + u^2}.$$

Multiplying out the numerator, a number of terms drop out, and the real part of the numerator is  $2u$ . This gives  $\operatorname{Re} z = x$  in the form

$$x = \frac{2u}{(1-v)^2 + u^2}.$$

This yields the circles

$$(v-1)^2 + \left(u - \frac{1}{c}\right)^2 = \frac{1}{c^2}$$

as claimed.

4. The inverse is

$$z = \frac{4w-1}{-2w+1}.$$

The fixed points  $z = -\frac{3}{4} \pm \frac{1}{4}\sqrt{17}$  are obtained as solutions of

$$2z^2 - (1-4)z - 1 = 0.$$

8.  $w = 1/(z+1)$ , almost without calculation  
 10.  $w = iz$ , a rotation, as a sketch of the points and their images shows.  
 12. Formula (2) gives

$$\frac{w+1}{w-\infty} \cdot \frac{-\infty}{1} = \frac{z}{z-i} \cdot \frac{-2i}{-i} = \frac{2z}{z-i}.$$

Replacing infinity on the left as indicated in the text, we get  $w+1$  on the left, so that the answer is

$$w = \frac{2z}{z-i} - 1 = \frac{z+i}{z-i}.$$

**Caution!** In setting up further problems by starting from the result, which is quite easy, one should check how complicated the solution, starting from (2), will be; this may often involve substantial work until one reaches the final form.

14. By (2),

$$\frac{w+1}{w-\infty} \cdot \frac{-\infty}{1} = \frac{z}{z+2i} \cdot \frac{4i}{2i};$$

hence, after getting rid of infinity,

$$w+1 = \frac{2z}{z+2i}, \quad w = \frac{2z}{z+2i} - 1 = \frac{z-2i}{z+2i}.$$

*Second solution.* 0 maps onto  $-1$ , hence  $d = -b$ . Next,  $2i$  maps onto 0, hence  $2ia + b = 0$ . Finally,  $-2i$  maps onto  $\infty$ , hence  $-2ic + d = 0$ . Choosing  $a = 1$  gives  $b = -2i$ ,  $d = 2i$ ,  $c = 1$  and confirms our previous result.

16. The requirement is that

$$w = u = \frac{ax+b}{cx+d}$$

must come out real for all real  $x$ . Hence the four coefficients must be real, except possibly for a common complex factor.

18.  $w = -(z^2 + i)/(iz^2 + 1)$   
 20. Substitute one LFT into the other and simplify.

**SECTION 17.4. Conformal Mapping by Other Functions, page 742**

**Purpose.** So far we have discussed mapping properties of  $z^n$ ,  $e^z$ , and linear fractional transformations. We now add to this a discussion of trigonometric and hyperbolic functions.

**SOLUTIONS TO PROBLEM SET 17.4, page 745**

2. Quarter-annulus  $1/e \leq |w| \leq 1$  in the first quadrant  $0 \leq \arg w \leq \pi/2$
4.  $e^{-3} < |w| < e^3$ ,  $\pi/4 < \arg w < 3\pi/4$
6. Right half of the interior of the unit circle  $|w| < 1$ ,  $-\pi/2 < \arg w < \pi/2$ , without the segment on the  $v$ -axis
10. The region in the right half-plane bounded by the  $v$ -axis and the hyperbola  $4u^2 - \frac{4}{3}v^2 = 1$  because

$$\sin z = u + iv = \sin x \cosh y + i \cos x \sinh y$$

reduces to

$$\sin iy = i \sinh y$$

when  $x = 0$ ; thus  $u = 0$  (the  $v$ -axis) is the left boundary of that region. For  $x = \pi/6$  we obtain

$$\sin(\pi/6 + iy) = \sin(\pi/6) \cosh y + i \cos(\pi/6) \sinh y;$$

thus

$$u = \frac{1}{2} \cosh y, \quad v = \frac{1}{2}\sqrt{3} \sinh y$$

and we obtain the right boundary curve of that region from

$$1 = \cosh^2 y - \sinh^2 y = 4u^2 - \frac{4}{3}v^2,$$

as asserted.

12. The region in the upper half-plane bounded by portions of the  $u$ -axis, the ellipse  $u^2/\cosh^2 3 + v^2/\sinh^2 3 = 1$  and the hyperbola  $u^2 - v^2 = \frac{1}{2}$ .

Indeed, for  $x = \pm\pi/4$  we get (see the formula for  $\sin z$  in the solution to Prob. 10)

$$\begin{aligned} \sin(\pm\frac{1}{4}\pi + iy) &= \sin(\pm\frac{1}{4}\pi) \cosh y + i \cos(\pm\frac{1}{4}\pi) \sinh y \\ &= \pm(1/\sqrt{2}) \cosh y + i(1/\sqrt{2}) \sinh y \end{aligned}$$

and from this

$$1 = \cosh^2 y - \sinh^2 y = 2u^2 - 2v^2, \quad \text{thus} \quad u^2 - v^2 = \frac{1}{2}.$$

For  $y = 0$  we get  $v = 0$  (the  $u$ -axis).

For  $y = 3$  we get

$$u = \sin x \cosh 3, \quad v = \cos x \sinh 3;$$

hence

$$1 = \sin^2 x + \cos^2 x = \frac{u^2}{\cosh^2 3} + \frac{v^2}{\sinh^2 3}.$$

14. If  $x = c$ , then (see the formula for  $\sin z$  in the solution to Prob. 10)

$$u = \sin c \cosh y, \quad v = \cos c \sinh y.$$

Hence if  $c = 0$ , then  $u = 0$ , so that the  $y$ -axis maps onto the  $v$ -axis.

If  $c = \frac{1}{2}\pi$ , then  $v = 0$ ,  $u \geq 1$ . If  $c = -\frac{1}{2}\pi$ , then  $v = 0$ ,  $u \leq -1$ .

If  $c \neq 0, \pm\frac{1}{2}\pi, \pm\pi, \dots$ , then we obtain hyperbolas

$$\frac{u^2}{\sin^2 c} - \frac{v^2}{\cos^2 c} = 1.$$

16.  $\cosh z = \cos(iz) = \sin\left(iz + \frac{1}{2}\pi\right)$
18. Interior of the ellipse  $u^2/\cosh^2 2 + v^2/\sinh^2 2 = 1$  in the fourth quadrant (which looks almost like a quarter of a circular disk because the curves of the cosh and the sinh eventually come close together).
20. The lower boundary segment maps onto  $\cos 1 \leq u \leq 1$  ( $v = 0$ ). The left and right boundary segments map onto portions of the hyperbola

$$\frac{u^2}{\cos^2 1} - \frac{v^2}{\sin^2 1} = 1.$$

The upper boundary segment maps onto a portion of the ellipse

$$\frac{u^2}{\cosh^2 1} + \frac{v^2}{\sinh^2 1} = 1.$$

22. The upper boundary maps onto the ellipse

$$\frac{u^2}{\cosh^2 1} + \frac{v^2}{\sinh^2 1} = 1$$

and the lower boundary onto the ellipse

$$\frac{u^2}{\cosh^2 \frac{1}{2}} + \frac{v^2}{\sinh^2 \frac{1}{2}} = 1.$$

Since  $0 < x < 2\pi$ , we get the entire ellipses as boundaries of the image of the given domain, which therefore is an elliptical ring.

Now the vertical boundaries  $x = 0$  and  $x = 2\pi$  map onto the same segment

$$\sinh \frac{1}{2} \leq u \leq \sinh 1$$

of the  $u$ -axis because for  $x = 0$  and  $x = 2\pi$  we have

$$u = \cosh y, \quad v = 0.$$

*Answer:* Elliptical annulus between those two ellipses and cut along that segment. See the figure.

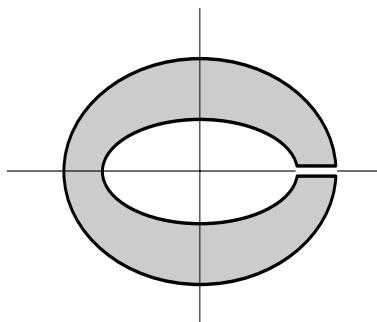

Section 17.4. Problem 22

24. The images of the five points in the figure in the text can be obtained directly from the given function  $w$ .

**SECTION 17.5. Riemann Surfaces. Optional, page 746**

**Purpose.** To introduce the idea and some of the simplest examples of Riemann surfaces, on which multivalued relations become single-valued, that is, functions in the usual sense.

**Short Courses.** This section may be omitted.

**SOLUTIONS TO PROBLEM SET 17.5, page 747**

4. By the hint we have

$$w = \sqrt{r_1} e^{i\theta_1/2} \sqrt{r_2} e^{i\theta_2/2} = \sqrt{r_1 r_2} e^{i(\theta_1 + \theta_2)/2}.$$

If we move from  $A$  in the first sheet (see the figure), we get into the second sheet at  $B$  (dashed curve) and get back to  $A$  after two loops around the branch point 1 (of first order).

Similarly for a loop around  $z = 2$  (without encircling  $z = 1$ ); this curve is not shown in the figure.

If we move from  $C$  and back to  $C$  as shown, we do not cross the cut, we stay in the same sheet, and we increase  $\theta_1$  and  $\theta_2$  by  $2\pi$  each. Hence  $(\theta_1 + \theta_2)/2$  is increased by  $2\pi$ , and we have completed one loop in the  $w$ -plane. This makes it plausible that two sheets will be sufficient for the present  $w$  and that the cut along which the two sheets are joined crosswise is properly chosen.

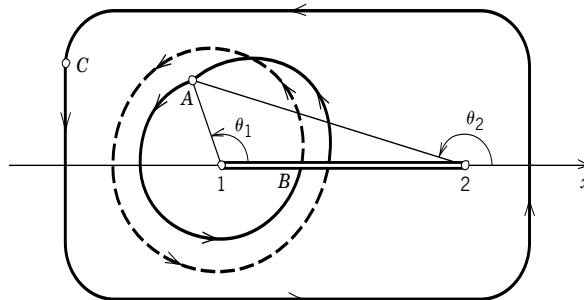

Section 17.5. Problem 4

6. Branch points at  $\pm 1$  and  $\pm 2$ , as shown in the figure, together with the cuts. If we pass a single cut, we get into the other sheet. If we cross two cuts, we are back in the sheet in which it started. The figure shows one path (A) that encircles two branch points and stays entirely in one sheet. The path from  $B$  and back to  $B$  also encloses two branch points, and since it crosses two cuts, part of it is in one sheet and part of it is in the other.

A discussion in terms of coordinates as in Prob. 4 would be similar to the previous one. Various other paths can be drawn and discussed in the figure.

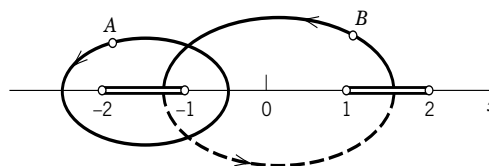

Section 17.5. Problem 6



8.  $4i/3$ , infinitely many sheets  
 10. No branch points because  $e^z$  is never zero; thus the two sheets are nowhere connected with each other. Thus  $\sqrt{e^z}$  represents two different functions, namely  $e^{z/2}$  and  $-e^{z/2}$ .

**SOLUTIONS TO CHAP. 17 REVIEW QUESTIONS AND PROBLEMS,  
 page 747**

12.  $v = 2xy = -8$   
 14.  $y = 0$  maps onto the nonnegative real axis  $u = x^2, v = 0$ . The other boundary  $y = 2$  gives  $u = x^2 - 4, v = 4x$ . Elimination of  $x$  gives the parabola

$$u = v^2/16 - 4,$$

with apex at  $u = -4$  and opening to the right.

*Answer:* The domain to the right of that parabola except for the nonnegative  $u$ -axis.

16. The  $w$ -plane except for the positive real axis, as follows from the fact that angles are doubled at the origin.  
 18. The image of the straight line  $y = 1$  must lie inside the unit circle; hence it must be a circle. The latter must pass through the image  $-i$  of  $i$  and through the image  $0$  of  $\infty$ . Hence the image must be the circle

$$|w + \frac{1}{2}i| = \frac{1}{2}.$$

By calculation this can be shown as follows. On the line  $y = 1$  we have  $z = x + i$ , hence

$$\frac{1}{x + i} = \frac{x - i}{x^2 + 1}, \quad \text{thus,} \quad u = \frac{x}{x^2 + 1}, \quad v = -\frac{1}{x^2 + 1}.$$

From this we obtain

$$\left(v + \frac{1}{2}\right)^2 = \left(\frac{1}{2} - \frac{1}{x^2 + 1}\right)^2 = \frac{(x^2 - 1)^2}{4(x^2 + 1)^2}.$$

It follows that

$$\left(v + \frac{1}{2}\right)^2 + u^2 = \frac{(x^2 + 1)^2}{4(x^2 + 1)^2} = \frac{1}{4},$$

in agreement with (1).

20.  $|w| > 2, v > 0$  because the lower half-plane ( $y < 0$ ) maps onto the upper half-plane ( $v > 0$ ).  
 22.  $u < 0, v < 0, |w| > 1$  because the interior of the unit circle maps onto the exterior, the left half-plane onto the left half-plane, and the upper half-plane onto the lower half-plane.  
 24.  $f'(z) = 2 \sinh 2z = -2i \sin 2iz = 0$  if  $2iz = \pm n\pi$ , hence the *answer* is  $z = \pm n\pi i/2, n = 0, 1, 2, \dots$ .  
 26.  $z = \pm\sqrt{n}, \pm i\sqrt{n}, n = 0, 1, 2, \dots$   
 28.  $f'(z) = 1 - z^{-2} = 0$  at  $z = \pm 1$ . Applications of this function were considered in Sec. 17.1, where  $z = \pm 1$  played a basic role in the construction of an airfoil.  
 30.  $w = (z + 1)/z$

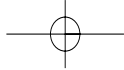

32.  $w = 1 + iz$ , a translation combined with a rotation
34.  $w = iz/(z - i)$
36.  $\pm i$
38.  $\pm 1$
40.  $\pm 3, \pm 3i$
42.  $w = 5/z$  maps  $|z| = 1$  onto  $|w| = 5$  and the interior onto the exterior. Hence  $w + 1 = 5/z$  will give the *answer*

$$w = -1 + \frac{5}{z} = \frac{5 - z}{z} .$$

44. To map a semidisk onto a disk, we have to double angles; thus  $w = z^2$  maps the given semidisk onto the unit disk  $|w| \leq 1$ , and the exterior is obtained by taking the reciprocal.  
*Answer:*  $w = 1/z^2$ .

## CHAPTER 18 Complex Analysis and Potential Theory

This is perhaps the most important justification for teaching complex analysis to engineers, and it also provides for nice applications of conformal mapping.

### SECTION 18.1. Electrostatic Fields, page 750

**Purpose.** To show how complex analysis can be used to discuss and solve two-dimensional electrostatic problems and to demonstrate the usefulness of **complex potential**, a major concept in this chapter.

#### Main Content, Important Concepts

Equipotential lines

Complex potential (2)

Combination of potentials by superposition

The main reason for using complex methods in two-dimensional potential problems is the possibility of using the complex potential, whose real and imaginary parts both have a physical meaning, as explained in the text. This fact should be emphasized in teaching from this chapter.

### SOLUTIONS TO PROBLEM SET 18.1, page 753

2.  $\Phi = 0.4x + 6.0$  kV,  $F = 0.4z + 6.0$
4.  $\Phi$  is expected to be linear because of the boundary (two parallel straight lines). From the boundary conditions and by inspection,

$$\Phi(x, y) = 100(y - x)/k.$$

This is the real part of the complex potential

$$F(z) = -100(1 + i)z/k.$$

The real potential can also be obtained systematically, starting from

$$\Phi(x, y) = ax + by + c.$$

By the first boundary condition, for  $y = x$  this is zero:

$$(1) \quad ax + bx + c = 0.$$

By the second boundary condition, for  $y = x + k$  this equals 100:

$$(2) \quad ax + b(x + k) + c = 100.$$

Subtract (1) from (2) to get

$$bk = 100, \quad b = 100/k.$$

Substitute this into (1) to get

$$ax + \frac{100}{k}x + c = \left(a + \frac{100}{k}\right)x + c = 0.$$

Since this is an identity in  $x$ , the coefficients must vanish,  $a = -100/k$  and  $c = 0$ . This gives the above result.

6. We have

$$\Phi(r) = a \ln r + b$$

and get from this and the two boundary conditions

$$\Phi(1) = b = 100$$

$$\Phi(10) = a \ln 10 + b = a \ln 10 + 100 = 1000.$$

Hence  $a = 900/\ln 10$ , so that the *answer* is

$$\Phi(r) = (900 \ln r)/\ln 10 + 100.$$

8.  $\Phi(r) = 100 - (50/\ln 10) \ln r$ ,  $F(z) = 100 - (50/\ln 10) \operatorname{Ln} z$

10.  $w = \frac{iz + 1 + i}{z + 1 + i}$ .  $w = 0$  gives  $z = z_0 = -1 + i$ ,  $\operatorname{Arg} z_0 = 3\pi/4$ . Hence at  $z_0$  the potential is  $(1/\pi)3\pi/4 = 3/4$ .

By considering the three given points and their images we see that the potential on the unit circle in the  $w$ -plane is 0 for the quarter-circle in the first quadrant and 1 for the other portion of the circle. This corresponds to a conductor consisting of two portions of a cylinder separated by small slits of insulation at  $w = 1$  and  $w = i$ , where the potential jumps.

12. **CAS Experiment.** (a)  $x^2 - y^2 = c$ ,  $xy = k$

(b)  $xy = c$ ,  $x^2 - y^2 = k$ ; the rotation caused by the multiplication by  $i$  leads to the interchange of the roles of the two families of curves.

(c)  $x/(x^2 + y^2) = c$  gives  $(x - 1/(2c))^2 + y^2 = 1/(4c^2)$ . Also,  $-y/(x^2 + y^2) = k$  gives the circles  $x^2 + (y + 1/(2k))^2 = 1/(4k^2)$ . All circles of both families pass through the origin.

(d) Another interchange of the families, compared to (c),  $(y - 1/(2c))^2 + x^2 = 1/(4c^2)$ ,  $(x - 1/(2k))^2 + y^2 = 1/(4k^2)$ .

14.  $\Phi = 110(x^3 - 3xy^2) = \operatorname{Re}(110z^3)$

## SECTION 18.2. Use of Conformal Mapping, page 754

**Purpose.** To show how conformal mapping helps in solving potential problems by mapping given domains onto simpler ones or onto domains for which the solution of the problem (subject to the transformed boundary conditions) is known.

The theoretical basis of this application of conformal mapping is given by Theorem 1, characterizing the behavior of harmonic functions under conformal mapping.

Problem 10 gives a hint on possibilities of generalizing potential problems for which the solution is known or can be easily obtained. The idea extends to more sophisticated situations.

## SOLUTIONS TO PROBLEM SET 18.2, page 757

2. Figure 383 in Sec. 17.1 shows  $D$  (a semi-infinite horizontal strip) and  $D^*$  (the upper half of the unit circular disk); and  $\Phi = e^x \cos y$ ,  $e^x \sin y = \frac{1}{2}e^{2x} \sin 2y = 0$  on  $y = 0$  and  $y = \pi$ , and  $\frac{1}{2} \sin 2y$  on the vertical boundary  $x = 0$  of  $D$ .

6.  $\Phi = 2 \sin x \cos x \cosh y \sinh y = \frac{1}{2} \sin 2x \sinh 2y = 0$  if  $x = 0$  or  $x = \frac{1}{2}\pi$  or  $y = 0$ , and  $\frac{1}{2} \sin 2x \sinh 2y = 1$  if  $y = 1$ .

8. **Team Project.** We map  $0 \mapsto r_0$ ,  $2c \mapsto -r_0$ , obtaining from (2) with  $b = z_0$  the conditions

$$r_0 = -\frac{-z_0}{-1} = z_0, \quad -r_0 = \frac{2c - z_0}{2z_0c - 1} = \frac{2c - r_0}{2r_0c - 1},$$

hence

$$r_0 = \frac{1}{2c} (1 - \sqrt{1 - 4c^2}).$$

$r_0$  is real for positive  $c \leq \frac{1}{2}$ . Note that with increasing  $c$  the image (an annulus) becomes slimmer and slimmer.

10.  $z = (2Z - i)/(-iZ - 2)$  by (3) in Sec. 17.3

12.  $\pm i$  are fixed points, and straight lines are mapped onto circles (or straight lines). From this the assertion follows. (Alternatively, it also follows very simply by setting  $x = 0$  and calculating  $|w|$ .)

14. Apply  $w = z^2$ .

### SECTION 18.3. Heat Problems, page 757

**Purpose.** To show that previous examples and new ones can be interpreted as potential problems in time-independent heat flow.

#### Comment on Interpretation Change

Boundary conditions of importance in one interpretation may be of no interest in another; this is about the only handicap in a change of interpretation. Hence one should emphasize that, in other words, whereas the unifying underlying theory remains the same, problems of interest will change from field to field of application. This can be seen most distinctly by comparing the problem sets in this chapter.

### SOLUTIONS TO PROBLEM SET 18.3, page 760

2. By inspection,

$$T(x, y) = 5 + 7.5(y - x).$$

This is the real part of the complex potential

$$F(z) = 5 - 7.5(1 + i)z.$$

A systematic derivation is as follows. The boundary and boundary values suggest that  $T(x, y)$  is linear in  $x$  and  $y$ ,

$$T(x, y) = ax + by + c.$$

From the boundary conditions,

$$(1) \quad T(x, x - 2) = ax + b(x - 2) + c = -10$$

$$(2) \quad T(x, x + 2) = ax + b(x + 2) + c = 20.$$

By addition,

$$2ax + 2bx + 2c = 10.$$

Since this is an identity in  $x$ , we must have  $a = -b$  and  $c = 5$ . From this and (1),

$$-bx + bx - 2b + 5 = -10.$$

Hence  $b = 7.5$ . This agrees with our result obtained by inspection.

4.  $T(x, y) = 20 + (90/\pi) \operatorname{Arg} z$ . This is quite similar to Example 3.
6. The lines of heat flow are perpendicular to the isotherms, and heat flows from higher to lower temperatures. Accordingly, heat flows from the portion of higher temperature of the unit circle  $|Z| = 1$  to that kept at a lower temperature, along the circular arcs that intersect the isotherms at right angles.

Of course, as temperatures on the boundary we must choose values that are physically possible, for example,  $20^\circ\text{C}$  and  $300^\circ\text{C}$ .

8. **Team Project.** (a)  $\operatorname{Arg} z$  or  $\operatorname{Arg} w$  is a basic building block when we have jumps in the boundary values. To obtain  $\operatorname{Arg} z$  or  $\operatorname{Arg} w$  as the real part of an analytic function (a logarithm), we have to multiply the logarithm by  $-i$ . Otherwise we just incorporate the real constants that appear in  $T(x, y)$ . *Answer:*

$$F^*(w) = T_1 - i \frac{T_2 - T_1}{\pi} \operatorname{Ln}(w - a),$$

$$T^*(u, v) = \operatorname{Re} F^*(w) = T_1 + \frac{T_2 - T_1}{\pi} \operatorname{Arg}(w - a).$$

- (b)  $w - a = z^2$ . Hence  $\operatorname{Arg}(w - a) = \operatorname{Arg} z^2 = 2 \operatorname{Arg} z$ . Thus (a) gives

$$T_1 + \frac{2}{\pi}(T_2 - T_1) \operatorname{Arg} z$$

and we see that  $T = T_1$  on the  $x$ -axis and  $T = T_2$  on the  $y$ -axis are the boundary data.

Geometrically, the  $a$  in  $w = a + z^2$  is a translation, and  $z^2$  opens the quadrant up onto the upper half-plane, so that the result of (a) becomes applicable and gives the potential in the quadrant.

- (c)  $T^* = \frac{T_0}{\pi} \operatorname{Arg}(w - 1) - \frac{T_0}{\pi} \operatorname{Arg}(w + 1)$ . This is the real part of

$$F^*(w) = -i \frac{T_0}{\pi} [\operatorname{Ln}(w - 1) - \operatorname{Ln}(w + 1)].$$

On the  $u$ -axis both arguments are 0 for  $u > 1$ , one equals  $\pi$  if  $-1 < u < 1$ , and both equal  $\pi$ , giving  $\pi - \pi = 0$  if  $u < -1$ .

- (d) The temperature is

$$T(x, y) = \frac{T_0}{\pi} \operatorname{Arg} \frac{\cosh z - 1}{\cosh z + 1}.$$

The boundary in Fig. 409 is mapped onto the  $u$ -axis;  $\cosh x$ ,  $0 \leq x < \infty$ , gives  $u \geq 1$ ;  $\cosh(x + \pi i) = -\cosh x$ ,  $0 \leq x < \infty$ , gives  $u < -1$ ; the vertical segment ( $x = 0$ ) is mapped onto  $-1 < u < 1$ .

10.  $(200/\pi) \operatorname{Arg} z$ . This is similar to Example 3.
12.  $T(x, y)$  satisfying the boundary conditions is obtained by adding 1 to the answer to Team Project 8(d) and choosing  $T_0 = -1$ ; thus

$$\begin{aligned}
 T(x, y) &= 100 - \frac{100}{\pi} \operatorname{Arg} \frac{\cosh z - 1}{\cosh z + 1} \\
 &= 100 - \frac{100}{\pi} \operatorname{Arg} \frac{(e^{z/2} - e^{-z/2})^2}{(e^{z/2} + e^{-z/2})^2} \\
 &= 100 - \frac{200}{\pi} \operatorname{Arg} \left( \tanh \frac{z}{2} \right) \\
 &= 100 - \frac{200}{\pi} \arctan \frac{\operatorname{Im} \tanh (z/2)}{\operatorname{Re} \tanh (z/2)}.
 \end{aligned}$$

In calculating these real and imaginary parts we use the abbreviations

$$Cx = \cosh (x/2), \quad Sx = \sinh (x/2)$$

and

$$cy = \cos (y/2), \quad sy = \sin (y/2).$$

Then

$$\tanh \frac{z}{2} = \frac{Sx cy + i Cx sy}{Cx cy + i Sx sy}.$$

We now multiply both numerator and denominator by the conjugate of the denominator. The numerator of the resulting expression is

$$N = (Sx cy + i Cx sy)(Cx cy - i Sx sy).$$

Its real part is

$$\operatorname{Re} N = Sx cy Cx cy + Cx Sx sy^2 = Cx Sx = \frac{1}{2} \sinh x.$$

Its imaginary part is

$$\operatorname{Im} N = -Sx^2 cy sy + Cx^2 sy cy = cy sy = \frac{1}{2} \sin y.$$

Hence the *answer* in its simplest form is

$$T(x, y) = 100 - \frac{200}{\pi} \arctan \frac{\sin y}{\sinh x}.$$

**14.** The *answer* is

$$\frac{100}{\pi} [\operatorname{Arg} (z^2 - 1) - \operatorname{Arg} (z^2 + 1)]$$

because  $w = z^2$  maps the first quadrant onto the upper half-plane with  $1 \mapsto 1$  and  $i \mapsto -1$ . The figure shows the transformed boundary conditions. The temperature is

$$\frac{100}{\pi} [\operatorname{Arg} (w - 1) - \operatorname{Arg} (w + 1)] = \frac{100}{\pi} [\operatorname{Arg} (z^2 - 1) - \operatorname{Arg} (z^2 + 1)],$$

in agreement with Team Project 8(c) with  $T_0 = 100$ .

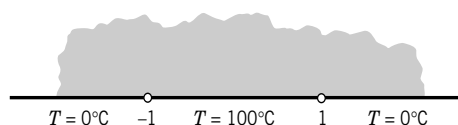

**Section 18.3.** Problem 14

**SECTION 18.4. Fluid Flow, page 761**

**Purpose.** To give an introduction to complex analysis in potential problems of fluid flow. These two-dimensional flows are given by their velocity vector field, and our presentation in the text begins with an explanation of handling this field by complex methods.

It is interesting that we use complex potentials as before, but whereas in electrostatics the real part (the real potential) is of central interest, here it is the imaginary part of the complex potential which gives the *streamlines* of the flow.

**Important Concepts**

Stream function  $\Psi$ , streamlines  $\Psi = \text{const}$

Velocity potential  $\Phi$ , equipotential lines  $\Phi = \text{const}$

Complex potential  $F = \Phi + i\Psi$

Velocity  $V = \overline{F'(z)}$

Circulation (6), vorticity, rotation (9)

Irrotational, incompressible

Flow around a cylinder (Example 2, Team Project 16)

**SOLUTIONS TO PROBLEM SET 18.4, page 766**

2.  $w = f(z) = iz^2/K, F^*(w) = -iKw, F(z) = F^*(w) = -iKiz^2/K = z^2$

4. Rotation of the whole flow pattern about the origin through the angle  $\alpha$

8.  $F(z) = iz^3 = i(x^3 + 3ix^2y - 3xy^2 - iy^3) = -3x^2y + y^3 + i(x^3 - 3xy^2)$  gives the streamlines

$$x(x^2 - 3y^2) = \text{const.}$$

This includes the three straight-line asymptotes  $x = 0$  and  $y = \pm x/\sqrt{3}$  (which make  $60^\circ$  angles with one another, dividing the plane into six angular regions of angle  $60^\circ$  each), and we could interpret the flow as a flow in such a region. This is similar to the case  $F(z) = z^2$ , where we had four angular regions of  $90^\circ$  opening each (the four quadrants of the plane) and the streamlines were hyperbolas. In the present case the streamlines look similar but they are “squeezed” a little so that each stays within its region, whose two boundary lines it has for asymptotes.

The velocity vector is

$$V = -6xy + 3i(y^2 - x^2)$$

so that  $V_2 = 0$  on  $y = x$  and  $y = -x$ . See the figure.

10.  $F(z) = iz^2 = i(x^2 - y^2) - 2xy$  gives the streamlines

$$x^2 - y^2 = \text{const}$$

The equipotential lines are

$$xy = \text{const.}$$

The velocity vector is

$$V = \overline{F'} = -2i\bar{z} = -2y - 2ix.$$

See the figure.

12.  $F(z) = z^2 + 1/z^2, \Psi = (r^2 - 1/r^2) \sin 2\theta = 0$  if  $r = 1$  (the cylinder wall) or  $\theta = 0, \pm \pi/2, \pi$ . The unit circle and the axes are streamlines. For large  $|z|$  the flow is “parallel” to the  $x$ -axis and also to the  $y$ -axis. For smaller  $|z|$  it is a flow in the first quadrant around a quarter of  $|z| = 1$ . Similarly in the other quadrants.



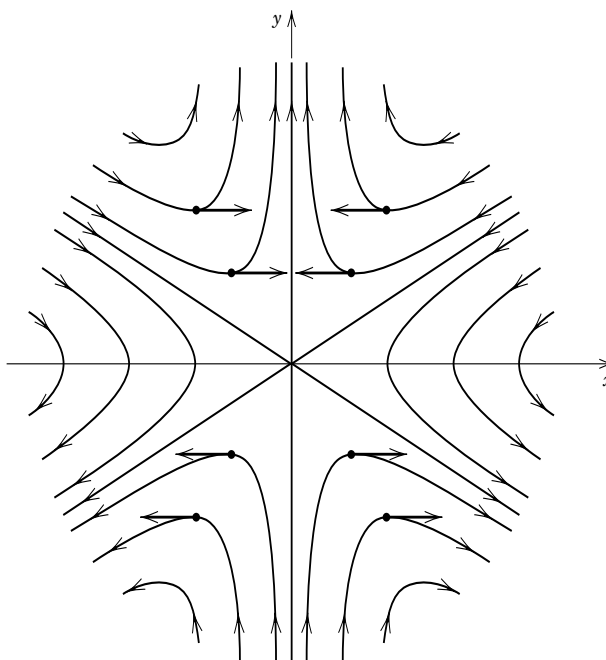

Section 18.4. Problem 8

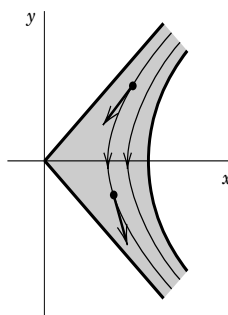

Section 18.4. Problem 10

14.  $w = \operatorname{arccosh} z$  implies

$$z = x + iy = \cosh w = \cos iw = \sin(iw + \frac{1}{2}\pi).$$

Along with an interchange of the roles of the  $z$ - and  $w$ -planes, this reduces the present problem to the consideration of the sine function in Sec. 17.4 (compare with Fig. 388). We now have the hyperbolas

$$\frac{x^2}{\sin^2 c} - \frac{y^2}{\cos^2 c} = 1$$

where  $c$  is different from the zeros of sine and cosine, and as limiting cases the  $y$ -axis and the two portions of the aperture.

16. **Team Project.** (b) We have

$$F(z) = -\frac{iK}{2\pi} \ln z = -\frac{iK}{2\pi} \ln |z| + \frac{K}{2\pi} \arg z.$$

Hence the streamlines are circles

$$\frac{K}{2\pi} \ln |z| = \text{const}, \quad \text{thus} \quad |z| = \text{const}.$$

The formula also shows the increase of the potential

$$\Phi(x, y) = \frac{K}{2\pi} \arg z$$

under an increase of  $\arg z$  by  $2\pi$ , as asserted in (b).

(d)  $F_1(z) = \frac{1}{2\pi} \ln(z + a)$  (source).  $F_2(z) = -\frac{1}{2\pi} \ln(z - a)$  (sink). The minus sign has the consequence that the flow is directed radially inward toward the sink because the velocity vector  $V$  is

$$\begin{aligned} V = \bar{F}'(z) &= -\frac{1}{2\pi} \cdot \frac{1}{\bar{z} - a} = -\frac{1}{2\pi} \cdot \frac{1}{x - iy - a} \\ &= -\frac{1}{2\pi} \cdot \frac{x - a + iy}{(x - a)^2 + y^2}. \end{aligned}$$

For instance, at  $z = a + i$  (above the sink),

$$V = -\frac{i}{2\pi},$$

which is directed vertically downward, that is, in the direction of the sink at  $a$ .

(e) The addition gives

$$\begin{aligned} F(z) &= z + \frac{1}{z} - \frac{iK}{2\pi} \ln z \\ &= x + \frac{x}{x^2 + y^2} + \frac{K}{2\pi} \arg z \\ &\quad + i \left( y - \frac{y}{x^2 + y^2} - \frac{K}{2\pi} \ln \sqrt{x^2 + y^2} \right). \end{aligned}$$

Hence the streamlines are

$$\Psi(x, y) = \text{Im } F(z) = y - \frac{y}{x^2 + y^2} - \frac{K}{2\pi} \ln \sqrt{x^2 + y^2} = \text{const}.$$

In both flows that we have added,  $|z| = 1$  is a streamline; hence the same is true for the flow obtained by the addition.

Depending on the magnitude of  $K$ , we may distinguish among three types of flow having either two or one or no stagnation points on the cylinder wall. The speed is

$$|V| = |\overline{F'(z)}| = |F'(z)| = \left| \left( 1 - \frac{1}{z^2} \right) - \frac{iK}{2\pi z} \right|.$$

We first note that  $|V| \rightarrow 1$  as  $|z| \rightarrow \infty$ ; actually,  $V \rightarrow 1$ , that is, for points at a great distance from the cylinder the flow is nearly parallel and uniform. The stagnation points are the solutions of the equation  $V = 0$ , that is,

$$(A) \quad z^2 - \frac{iK}{2\pi} z - 1 = 0.$$

We obtain

$$z = \frac{iK}{4\pi} \pm \sqrt{\frac{-K^2}{16\pi^2} + 1}.$$

If  $K = 0$  (no circulation), then  $z = \pm 1$ , as in Example 2. As  $K$  increases from 0 to  $4\pi$ , the stagnation points move from  $z = \pm 1$  up on the unit circle until they unite at  $z = i$ . The value  $K = 4\pi$  corresponds to a double root of the equation (A). If  $K > 4\pi$ , the roots of (A) become imaginary, so that one of the stagnation points lies on the imaginary axis in the field of flow while the other one lies inside the cylinder, thus losing its physical meaning.

### SECTION 18.5. Poisson's Integral Formula for Potentials, page 768

**Purpose.** To represent the potential in a standard region (a disk  $|z| \leq R$ ) as an integral (5) over the boundary values; to derive from (5) a series (7) that gives the potential and for  $|z| = R$  is the Fourier series of the boundary values. So here we see another important application of Fourier series, much less obvious than that of vibrational problems, where one can "see" the cosine and sine terms of the series.

#### Comment on Footnote 2

Poisson's discovery (1812) that Laplace's equation holds only outside the masses (or charges) resulted in the Poisson equation (Sec. 12.1). The publication on the Poisson distribution (Sec. 24.7) appeared in 1837.

### SOLUTIONS TO PROBLEM SET 18.5, page 771

4.  $r^2 \sin 2\theta$

6.  $\cos^2 5\theta = \frac{1}{2} + \frac{1}{2} \cos 10\theta$  gives the answer  $\frac{1}{2} + \frac{1}{2}r^{10} \cos 10\theta$ .

8.  $\pi - 2 \left( r \sin \theta + \frac{r^2}{2} \sin 2\theta + \frac{r^3}{3} \sin 3\theta + \cdots \right)$ .

Note that  $\Phi(1, \theta)$  is neither even nor odd, but  $\Phi(1, \theta) - \pi$  is odd, so that we get a sine series plus the constant term  $\pi$ .

10.  $\cos^4 \theta = \frac{3}{8} + \frac{1}{2} \cos 2\theta + \frac{1}{8} \cos 4\theta$  gives the answer

$$\frac{3}{8} + \frac{1}{2}r^2 \cos 2\theta + \frac{1}{8}r^4 \cos 4\theta.$$

12.  $\frac{1}{2} + \frac{2}{\pi} \left( r \cos \theta - \frac{1}{3}r^3 \cos 3\theta + \frac{1}{5}r^5 \cos 5\theta - \cdots \right)$

14. **Team Project.** (a)  $r = 0$  in (5) gives  $\Phi(0) = \frac{1}{2\pi} \int_0^{2\pi} \Phi(R, \alpha) d\alpha$ . Note that the interval of integration has length  $2\pi$ , not  $2\pi R$ .

(b)  $\nabla^2 u = 0$ ,  $u = g(r)h(\theta)$ ,  $g''h + \frac{1}{r} g'h + \frac{1}{r^2} gh'' = 0$ ; hence by separating variables

$$r^2 \frac{g''}{g} + r \frac{g'}{g} = n^2, \quad \frac{h''}{h} = -n^2, \quad h = a_n \cos n\theta + b_n \sin n\theta.$$

Also,

$$r^2 g'' + r g' - n^2 g = 0.$$

A solution is  $r^n/R^n$ .

(c) By the Cauchy–Riemann equations,

$$\Psi_r = -\frac{1}{r} \Phi_\theta = -\sum_{n=1}^{\infty} \frac{r^{n-1}}{R^n} (-a_n \sin n\theta + b_n \cos n\theta)n,$$

$$\Psi = \Psi(0) + \sum_{n=1}^{\infty} \left(\frac{r}{R}\right)^n (-b_n \cos n\theta + a_n \sin n\theta).$$

(d) From the series for  $\Phi$  and  $\Psi$  we obtain by addition

$$F(z) = a_0 + i\Psi(0) + \sum_{n=1}^{\infty} \left(\frac{r}{R}\right)^n [(a_n - ib_n) \cos n\theta + i(a_n - ib_n) \sin n\theta]$$

$$= a_0 + i\Psi(0) + \sum_{n=1}^{\infty} \left(\frac{r}{R}\right)^n (a_n - ib_n)e^{in\theta},$$

$$a_n - ib_n = \frac{1}{\pi} \int_0^{2\pi} \Phi(R, \alpha) e^{-in\alpha} d\alpha.$$

Using  $z = re^{i\theta}$ , we have the power series

$$F(z) = a_0 + i\Psi(0) + \sum_{n=1}^{\infty} \frac{a_n - ib_n}{R^n} z^n.$$

## SECTION 18.6. General Properties of Harmonic Functions, page 771

**Purpose.** We derive general properties of analytic functions and from them corresponding properties of harmonic functions.

### Main Content, Important Properties

Mean value of analytic functions over circles (Theorem 1)

Mean value of harmonic functions over circles, over disks (Theorem 2)

Maximum modulus theorem for analytic functions (Theorem 3)

Maximum principle for harmonic functions (Theorem 4)

Uniqueness theorem for the Dirichlet problem (Theorem 5)

### Comment on Notation

Recall that we introduced  $F$  to reserve  $f$  for conformal mappings (beginning in Sec. 18.2), and we continue to use  $F$  also in this last section of Chap. 18.

## SOLUTIONS TO PROBLEM SET 18.6, page 774

2. Use (2). We obtain

$$F(2) = 27 = \frac{1}{2\pi} \int_0^{2\pi} (3 + e^{i\alpha})^3 d\alpha = \frac{1}{2\pi} (2\pi \cdot 27 + 0).$$

4. Use (2).  $F(0) = 0$

6. By (3) with  $r_0 = 1$ ,

$$\begin{aligned} & \frac{1}{\pi} \int_0^1 \int_0^{2\pi} [(3 + \cos \alpha)^2 - (8 + \sin \alpha)^2] r \, dr \, d\alpha \\ &= \frac{1}{2\pi} \int_0^{2\pi} [(3 + \cos \alpha)^2 - (8 + \sin \alpha)^2] d\alpha \\ &= \frac{1}{2\pi} \left[ \left( 9 + 0 + \frac{1}{2} \right) - \left( 64 + 0 + \frac{1}{2} \right) \right] \cdot 2\pi = -55. \end{aligned}$$

8. Set  $r = 0$ .

10. **Team Project.** (a) (i) Polar coordinates show that  $|F(z)| = |z|^2$  assumes its maximum 52 and its minimum 20 at the boundary points  $6 + 4i$  and  $4 + 2i$ , respectively, and at no interior point.

(ii) Use the fact that  $|e^{3z}| = e^{3x}$  is monotone.

(iii) At  $z = \pm i$  we obtain the maximum

$$|F(z)| = [\sin^2 x + \sinh^2 y]^{1/2} = \sinh 1 = 1.1752$$

and at  $z = 0$  the minimum 0.

(b)  $|\cos z|^2 = \cos^2 x + \sinh^2 y$  (Sec. 13.6) shows that, for instance, in the unit disk the maximum  $\sqrt{1 + \sinh^2 1} = 1.5431$  is taken at  $z = \pm i$ .

(c)  $F(z)$  is not analytic.

(d) The extension is simple. Since the interior  $R$  of  $C$  is simply connected, Theorem 3 applies. The maximum of  $|F(z)|$  is assumed on  $C$ , by Theorem 3, and if  $F(z)$  had no zeros inside  $C$ , then, by Theorem 3, it would follow that  $|F(z)|$  would also have its minimum on  $C$ , so that  $F(z)$  would be constant, contrary to our assumption. This proves the assertion.

The fact that  $|F(z)| = \text{const}$  implies  $F(z) = \text{const}$  for any analytic function  $F(z)$  was shown in Example 3, Sec. 13.4.

12. Since  $|z| \leq 1$ , the triangle inequality yields  $|az + b| \leq |a| + |b|$ . The maximum lies on  $|z| = 1$ . Write  $a = |a|e^{i\alpha}$ ,  $z = e^{i\theta}$ ,  $b = |b|e^{i\beta}$ . Choose  $\theta = \beta - \alpha$ . Then

$$|az + b| = \left| |a|e^{i\alpha+i(\beta-\alpha)} + |b|e^{i\beta} \right| = (|a| + |b|)|e^{i\beta}| = |a| + |b|.$$

Answer:  $|a| + |b|$ , taken at  $z = e^{i(\beta-\alpha)}$ .

14.  $e^x \leq e^b$  with equality only at  $b$ . Also,  $\cos y \leq 1$  with equality only at 0 and  $2\pi$ , and  $(b, 0)$  and  $(b, 2\pi)$  lie on the boundary.

16.  $\Phi = \exp(x^2 - y^2) \cos 2xy$ ,  $R: |z| \leq 1, x \geq 0, y \geq 0$ . Yes,  $(u_1, v_1) = (1, 0)$  is the image of  $(x_1, y_1) = (1, 0)$ ; this is typical.  $(u_1, v_1)$  is found by noting that on the boundary (semicircle),  $\Phi^* = e^u \cos(\sqrt{1 - u^2})$  increases monotone with  $u$ . Similarly for  $R$ .

### SOLUTIONS TO CHAP. 18 REVIEW QUESTIONS AND PROBLEMS, page 775

12.  $\Phi = (20/\ln 10) \ln r$

14.  $\Phi = (220 \ln r)/\ln 4$ ;  $\Phi = 0$  if  $r = 1$ , the unit circle, which is closer to the inner circle than to the outer, reflecting the convexity of the curve of the logarithm.

16.  $\Phi = 10 - (12/\pi) \text{Arg } z$

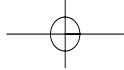

18.  $\Phi = \frac{x+y}{x^2+y^2} = \frac{1}{2c}$ ,  $(x-c)^2 + (y-c)^2 = 2c^2$ , circles through the origin with center on  $y = x$ .

20.  $\Phi = 600[1 + (2/\pi) \text{Arg } z]$ , so that the answer is 900 V and 600 V.

22.  $T(x, y) = 50 \left[ 1 - \frac{1}{\pi} \text{Arg } (z - 2) \right]$

24. 43.22°C, which is obtained as follows. We have

$$T(r) = a \ln r + b$$

and at the outer cylinder,

$$(1) \quad T(10) = a \ln 10 + b = 20$$

and from the condition to be achieved

$$(2) \quad T(5) = a \ln 5 + b = 30.$$

(1) subtracted from (2) gives

$$a(\ln 5 - \ln 10) = 10, \quad a = 10/\ln \frac{1}{2} = -14.43.$$

From this and (1)

$$b = 20 - a \ln 10 = 53.22.$$

Hence on the inner cylinder we should have

$$T(2) = a \ln 2 + b = 43.22.$$

26.  $z/4 + 4/z$

28.  $25 - \frac{100}{\pi} \left( r \cos \theta - \frac{1}{3} r^3 \cos 3\theta + \frac{1}{5} r^5 \cos 5\theta - + \dots \right)$

30.  $\frac{1}{3} \pi^2 - 4(r \cos \theta - \frac{1}{4} r^2 \cos 2\theta + \frac{1}{9} r^3 \cos 3\theta - \frac{1}{16} r^4 \cos 4\theta + - \dots)$

## PART E. Numeric Analysis

The subdivision into three chapters has been retained. All three chapters have been updated in the light of computer requirements and developments. A list of suppliers of software (with addresses etc.) can be found at the beginning of Part E of the book and another list at the beginning of Part G.

### CHAPTER 19 Numerics in General

#### Major Changes

Updating of this chapter consists of the inclusion of ideas, such as error estimation by halving, changes in Sec. 19.4 on splines, the presentation of adaptive integration and Romberg integration, and further error estimation techniques in integration.

#### SECTION 19.1. Introduction, page 780

**Purpose.** To familiarize the student with some facts of numerical work in general, regardless of the kind of problem or the choice of method.

#### Main Content, Important Concepts

Floating-point representation of numbers, overflow, underflow,  
 Roundoff  
 Concept of algorithm  
 Stability  
 Errors in numerics, their propagation, error estimates  
 Loss of significant digits

**Short Courses.** Mention the roundoff rule and the definitions of error and relative error.

#### SOLUTIONS TO PROBLEM SET 19.1, page 786

2.  $-0.286403 \cdot 10^{-1}$ ,  $0.112584 \cdot 10^2$ ,  $-0.316816 \cdot 10^5$   
 6. 19.9499, 0.0501; 19.9499, 0.0501256  
 8.  $-99.980$ ,  $-0.020$ ;  $-99.980$ ,  $-0.020004$   
 10. Small terms first.  $(0.0004 + 0.0004) + 1.000 = 1.001$ , but  
 $(1.000 + 0.0004) + 0.0004 = 1$  (4S)  
 14. The proof is practically the same as that in the text. With the same notation we get
- $$\begin{aligned} |\epsilon| &= |x + y - (\tilde{x} + \tilde{y})| \\ &= |(x - \tilde{x}) + (y - \tilde{y})| \\ &= |\epsilon_1 + \epsilon_2| \leq |\epsilon_1| + |\epsilon_2| \leq \beta_1 + \beta_2. \end{aligned}$$
16. Since  $x_2 = 2/x_1$  and 2 is exact,  $|\epsilon_r(x_2)| = |\epsilon_r(x_1)|$  by Theorem 1b. Since  $x_1$  is rounded to 4S, we have  $|\epsilon(x_1)| \leq 0.005$ , hence
- $$|\epsilon_r(x_1)| \leq 0.005/39.95.$$

This implies

$$\begin{aligned} |\epsilon(x_2)| &= |\epsilon_r(x_2)x_2| = |\epsilon_r(x_1)x_2| \\ &\leq (0.005/39.95) \cdot 0.0506 \\ &< 0.00001. \end{aligned}$$

$$18. 61.2 - 7.5 \cdot 15.5 + 11.2 \cdot 3.94 + 2.80 = 61.2 - 116 + 44.1 + 2.80 = -7.90$$

$$\begin{aligned} ((x - 7.5)x + 11.2)x + 2.80 &= (-3.56 \cdot 3.94 + 11.2)3.94 + 2.80 \\ &= (-14.0 + 11.2)3.94 + 2.80 \\ &= -11.0 + 2.80 = -8.20 \end{aligned}$$

*Exact:*  $-8.336016$

### SECTION 19.2. Solution of Equations by Iteration, page 787

**Purpose.** Discussion of the most important methods for solving equations  $f(x) = 0$ , a very important task in practice.

#### Main Content, Important Concepts

Solution of  $f(x) = 0$  by iteration (3)  $x_{n+1} = g(x_n)$

Condition sufficient for convergence (Theorem 1)

Newton (–Raphson) method (5)

Speed of convergence, order

Secant, bisection, false position methods

#### Comments on Content

Fixed-point iteration gives the opportunity to discuss the idea of a **fixed point**, which is also of basic significance in modern theoretical work (existence and uniqueness of solutions of differential, integral, and other functional equations).

The less important *method of bisection* and *method of false position* are included in the problem set.

### SOLUTIONS TO PROBLEM SET 19.2, page 796

$$2. x_0 = 1, x_1 = 0, x_2 = 1, x_3 = 0, \dots$$

$$x_0 = 0.5, x_1 = 0.875, x_2 = 0.330, \dots$$

$$x_0 = 2, x_1 = -7, x_2 = 344, x_3 = -40\,707\,583, \dots$$

$$4. g = \sqrt[4]{x - 0.2}, 1, 0.9457, 0.9293, 0.9241, 0.9225, 0.9220, 0.9218, 0.9217, 0.9217$$

$$6. x = x/(e^{0.5x} \sin x), 1, 0.7208, 0.7617, 0.7541, 0.7555, 0.7553, 0.7553, 0.7553$$

8. **CAS Project.** (a) This follows from the intermediate value theorem of calculus.

(b) Roots  $r_1 = 1.56155$  (6S-value),  $r_2 = -1$  (exact),  $r_3 = -2.56155$  (6S-value).

(1)  $r_1$ , about 12 steps, (2)  $r_1$ , about 25 steps, (3) convergent to  $r_2$ , divergent, (4) convergent to 0, divergent, (5)  $r_3$ , about 7 steps, (6)  $r_2$ , divergent, (7)  $r_1$ , 4 steps; this is Newton.

$$10. 0.750364, 0.739113, 0.739085, 0.739085$$

$$12. 1.537902, 1.557099, 1.557146, 1.557146$$

$$14. 2, 2.452, 2.473; \text{ temperature } 39.02^\circ\text{C}$$



16. (a) 0.906180 (6S exact, 4 steps,  $x_0 = 1$ ). (b)  $\frac{1}{3}\sqrt{5 + \frac{2}{7}\sqrt{70}} = 0.906179846$

$$18. f(x) = x^k - c, \quad x_{n+1} = x_n - (x_n - c/x_n^{k-1})/k \\ = \left(1 - \frac{1}{k}\right)x_n + \frac{c}{kx_n^{k-1}}.$$

In each case,  $x_4$  is the first value that gives the desired accuracy, 1.414 214, 1.259 921, 1.189 207, 1.148 698.

20. **Team Project.** (a)

**ALGORITHM REGULA FALSI ( $f$ ,  $a_0$ ,  $b_0$ ,  $\epsilon$ ,  $N$ ). Method of False Position**

This algorithm computes an interval  $[a_n, b_n]$  containing a solution of  $f(x) = 0$  ( $f$  continuous) or a solution  $c_n$ .

INPUT: Continuous function  $f$ , initial interval  $[a_0, b_0]$ , tolerance  $\epsilon$ , maximum number of iterations  $N$ .

OUTPUT: Interval  $[a_n, b_n]$  containing a solution, or a solution  $c_n$ , or message of failure.

For  $n = 0, 1, \dots, N - 1$  do:

$$\text{Compute } c_n = \frac{a_n f(b_n) - b_n f(a_n)}{f(b_n) - f(a_n)}.$$

If  $f(c_n) = 0$  then OUTPUT  $c_n$ . Stop. [*Successful completion*]

Else continue.

If  $f(a_n)f(c_n) < 0$  then set  $a_{n+1} = a_n$  and  $b_{n+1} = c_n$ .

Else set  $a_{n+1} = c_n$  and  $b_{n+1} = b_n$ .

If  $b_{n+1} - a_{n+1} \leq \epsilon$  then OUTPUT  $[a_{n+1}, b_{n+1}]$ . Stop.

[*Successful completion*]

Else continue.

End

OUTPUT  $[a_N, b_N]$  and message "Failure". Stop.

[*Unsuccessful completion;  $N$  iterations did not give an interval of length not exceeding the tolerance.*]

End REGULA FALSI

(b) 2.68910, (c) 1.18921, 0.64171, 1.55715

22. 1, 0.7, 0.577094, 0.534162, 0.531426, 0.531391, 531391

24. 0.5, 1, 0.725482, 0.738399, 0.739087, 0.739085, 0.739085

### SECTION 19.3. Interpolation, page 797

**Purpose.** To discuss methods for interpolating (or extrapolating) given data  $(x_0, f_0), \dots, (x_n, f_n)$ , all  $x_j$  different, arbitrarily or equally spaced, by polynomials of degree not exceeding  $n$ .

#### Main Content, Important Concepts

Lagrange interpolation (4) (arbitrary spacing)

Error estimate (5)

Newton's divided difference formula (10) (arbitrary spacing)

Newton's difference formulas (14), (18) (equal spacing)

**Short Courses.** Lagrange's formula briefly, Newton's forward difference formula (14).

**Comment on Content**

For given data, the interpolation polynomial  $p_n(x)$  is unique, regardless of the method by which it is derived. Hence the error estimate (5) is generally valid (provided  $f$  is  $n + 1$  times continuously differentiable).

**SOLUTIONS TO PROBLEM SET 19.3, page 808**

2. This parallels Example 3. From (5) we get

$$\epsilon_1(9.4) = (x - 9)(x - 9.5) \frac{f''(t)}{2} \Big|_{x=9.4} = \frac{0.02}{t^2},$$

where  $9 \leq t \leq 9.5$ . Now the right side is a monotone function of  $t$ , hence its extrema occur at 9.0 and 9.5. We thus obtain

$$0.00022 \leq a - \tilde{a} \leq 0.00025.$$

This gives the *answer*

$$2.2407 \leq a \leq 2.2408.$$

2.2407 is exact to 4D.

4. From (5) we obtain

$$\epsilon_2(9.2) = (x - 9)(x - 9.5)(x - 11) \frac{(\ln t)'''}{6} \Big|_{x=9.2} = \frac{0.036}{t^3}.$$

The right side is monotone in  $t$ , hence its extreme values occur at the ends of the interval  $9 \leq t \leq 11$ . This gives

$$0.000027 \leq \epsilon_2(9.4) = a - \tilde{a} \leq 0.000049$$

and by adding  $\tilde{a} = 2.2192$  (and rounding)

$$2.2192 \leq a \leq 2.2193.$$

6. From (5) we obtain

$$\epsilon_2(0.75) = (x - 0.25)(x - 0.5)(x - 1) \frac{f'''(t)}{6} \Big|_{x=0.75} = -0.005208 f'''(t)$$

where, by differentiation,

$$f'''(t) = \frac{-4}{\sqrt{\pi}} (1 - 2t^2)e^{-t^2}.$$

Another differentiation shows that  $f'''$  is monotone on the interval  $0.25 \leq t \leq 1$  because

$$f^{iv} = -\frac{8t}{\sqrt{\pi}} (-3 + 2t^2)e^{-t^2} \neq 0$$

on that interval. Hence the extrema of  $f'''$  occur at the ends of the interval, so that we obtain

$$-0.00432 \leq a - \tilde{a} \leq 0.00967$$

and by adding  $\tilde{a} = 0.70929$

$$0.70497 \leq a \leq 0.71896.$$

*Exact:* 0.71116 (5D).

8. 0.8032 ( $\epsilon = -0.0244$ ), 0.4872 ( $\epsilon = -0.0148$ ); the quadratic interpolation polynomial is

$$p_2(x) = 0.3096x^2 - 0.9418x + 1$$

and gives the values 0.7839 ( $\epsilon = -0.0051$ ) and 0.4678 ( $\epsilon = 0.0046$ ).

10. From

$$L_0(x) = x^2 - 20.5x + 104.5$$

$$L_1(x) = \frac{1}{0.75} (-x^2 + 20x - 99)$$

$$L_2(x) = \frac{1}{3} (x^2 - 18.5x + 85.5)$$

(see Example 2) and the 5S-values of the logarithm in the text we obtain

$$p_2(x) = -0.005233x^2 + 0.205017x + 0.775950.$$

This gives the values and errors

$$2.2407, \quad \text{error } 0$$

$$2.3028, \quad \text{error } -0.0002$$

$$2.3516, \quad \text{error } -0.0002$$

$$2.4415, \quad \text{error } 0.0008$$

$$2.4826, \quad \text{error } 0.0024.$$

It illustrates that in extrapolation one may usually get less accurate values than one does in interpolation.  $p_2(x)$  would change if we took more accurate values of the logarithm.

12.  $4x^2 - 6x + 5$

14.  $p_2(x) = 1.0000 - 0.0112r + 0.0008r(r-1)/2 = x^2 - 2.580x + 2.580$ ,  
 $r = (x-1)/0.02$ ; 0.9943, 0.9835, 0.9735

16. The divided difference table is

| $x_j$ | $f(x_j)$ | $f[x_j, x_{j+1}]$ | $f[x_j, x_{j+1}, x_{j+2}]$ | $f[x_j, \dots, x_{j+3}]$ |
|-------|----------|-------------------|----------------------------|--------------------------|
| 6.0   | 0.1506   |                   |                            |                          |
|       |          | 0.1495            |                            |                          |
| 7.0   | 0.3001   |                   | -0.1447                    |                          |
|       |          | -0.0676           |                            | 0.0088                   |
| 7.5   | 0.2663   |                   | -0.1299                    |                          |
|       |          | -0.1585           |                            |                          |
| 7.7   | 0.2346   |                   |                            |                          |

From it and (10) we obtain

$$\begin{aligned} p_3(6.5) &= 0.1506 + (6.5 - 6.0) \cdot 0.1495 \\ &\quad + (6.5 - 6.0)(6.5 - 7.0) \cdot (-0.1447) \\ &\quad + (6.5 - 6.0)(6.5 - 7.0)(6.5 - 7.5) \cdot 0.0088 \\ &= 0.2637. \end{aligned}$$

18. The difference table is

| $x_j$ | $J_1(x_j)$ | $\Delta$ | $\Delta^2$ | $\Delta^3$ | $\Delta^4$ | $\Delta^5$ |
|-------|------------|----------|------------|------------|------------|------------|
| 0.0   | 0.00000    | 9950     |            |            |            |            |
| 0.2   | 0.09950    | 9653     | -297       |            |            |            |
| 0.4   | 0.19603    | 9067     | -586       | -289       | 22         |            |
| 0.6   | 0.28670    | 8214     | -853       | -267       | 27         | 5          |
| 0.8   | 0.36884    | 7121     | -1093      | -240       |            |            |
| 1.0   | 0.44005    |          |            |            |            |            |

From this and (14) we get by straightforward calculation

$$p_5(x) = 0.00130x^5 + 0.00312x^4 - 0.06526x^3 + 0.00100x^2 + 0.49988x.$$

This gives as the values of  $J_1(x)$ ,  $x = 0.1, 0.3, 0.5, 0.7, 0.9$ ,

$$0.04993, \quad 0.14832, \quad 0.24227, \quad 0.32899, \quad 0.40595,$$

the errors being 1, 0, 0, 1, 0 unit of the last given digit.

22. **Team Project.** (a) For  $p_1(x)$  we need

$$L_0 = \frac{x - x_1}{x_0 - x_1} = 19 - 2x, \quad L_1 = \frac{x - x_0}{x_1 - x_0} = -18 + 2x$$

$$\begin{aligned} p_1(x) &= 2.19722(19 - 2x) + 2.25129(-18 + 2x) \\ &= 1.22396 + 0.10814x, \end{aligned}$$

$$p_1(9.2) = 2.21885.$$

Exact, 2.21920, error 0.00035.

For  $p_2$  we need

$$L_0 = 104.5 - \frac{41}{2}x + x^2$$

$$L_1 = -132 + \frac{80}{3}x - \frac{4}{3}x^2$$

$$L_2 = 28.5 - \frac{37}{6}x + \frac{1}{3}x^2$$

This gives (with 10S-values for the logarithm)

$$p_2(x) = 0.779466 + 0.204323x - 0.0051994x^2,$$

hence  $p_2(9.2) = 2.21916$ , error 0.00004. The error estimate is

$$p_2(9.2) - p_1(9.2) = 0.00031.$$

(b) Extrapolation gives a much larger error. The difference table is

|     |        |         |         |
|-----|--------|---------|---------|
| 0.2 | 0.9980 |         |         |
|     |        | -0.0294 |         |
| 0.4 | 0.9686 |         | -0.0949 |
|     |        | -0.1243 |         |
| 0.6 | 0.8443 |         | -0.1842 |
|     |        | -0.3085 |         |
| 0.8 | 0.5358 |         | -0.2273 |
|     |        | -0.5358 |         |
| 1.0 | 0.0000 |         |         |

The differences not shown are not needed. Taking  $x = 0.6, 0.8, 1.0$  gives the best result. Newton's formula (14) with  $r = 0.1/0.2 = 0.5$  gives

$$0.8443 + 0.5 \cdot (-0.3085) + \frac{0.5 \cdot (-0.5)}{2} \cdot (-0.2273) = 0.7185, \quad \epsilon = -0.0004.$$

Similarly, by taking  $x = 0.4, 0.6, 0.8$  we obtain

$$0.9686 + 1.5 \cdot (-0.1243) + \frac{1.5 \cdot 0.5}{2} \cdot (-0.1842) = 0.7131, \quad \epsilon = 0.0050.$$

Taking  $x = 0.2, 0.4, 0.6$ , we extrapolate and get a much poorer result:

$$0.9980 + 2.5 \cdot (-0.0294) + \frac{2.5 \cdot 1.5}{2} \cdot (-0.0949) = 0.7466, \quad \epsilon = -0.0285.$$

(e) 0.386 4185, exact to 7S.

### SECTION 19.4. Splines, page 810

**Purpose.** Interpolation of data  $(x_0, f_0), \dots, (x_n, f_n)$  by a (cubic) spline, that is, a twice continuously differentiable function

$$g(x)$$

which in each of the intervals between adjacent nodes is given by a polynomial of third degree at most,

$$\text{on } [x_0, x_1] \text{ by } q_0(x), \quad \text{on } [x_1, x_2] \text{ by } q_1(x), \quad \dots, \quad \text{on } [x_{n-1}, x_n] \text{ by } q_{n-1}(x).$$

**Short Courses.** This section may be omitted.

#### Comments on Content

Higher order polynomials tend to oscillate between nodes—the polynomial  $P_{10}(x)$  in Fig. 431 is typical—and splines were introduced to avoid that phenomenon. This motivates their application.

It is stated in the text that splines also help lay the foundation of **CAD (computer-aided design)**.

If we impose the additional condition (3) with given  $k_0$  and  $k_n$  (tangent direction of the spline at the beginning and at the end of the total interval considered), then for given data the cubic spline is unique.

### SOLUTIONS TO PROBLEM SET 19.4, page 815

2. Writing  $f(x_j) = f_j$ ,  $f(x_{j+1}) = f_{j+1}$ ,  $x - x_j = F$ ,  $x - x_{j+1} = G$ , we get (6) in the form

$$\begin{aligned} q_j(x) &= f_j c_j^2 G^2 (1 + 2c_j F) \\ &\quad + f_{j+1} c_j^2 F^2 (1 - 2c_j G) \\ &\quad + k_j c_j^2 F G^2 \\ &\quad + k_{j+1} c_j^2 F^2 G. \end{aligned}$$

If  $x = x_j$ , then  $F = 0$ , so that because  $c_j = 1/(x_{j+1} - x_j)$ ,

$$q_j(x_j) = f_j c_j^2 (x_j - x_{j+1})^2 = f_j.$$

Similarly, if  $x = x_{j+1}$ , then  $G = 0$  and

$$q_j(x_{j+1}) = f_{j+1}c_j^2(x_{j+1} - x_j)^2 = f_{j+1}.$$

This verifies (4).

By differentiating (6) we obtain

$$\begin{aligned} q_j'(x) &= f_jc_j^2[2G(1 + 2c_jF) + 2c_jG^2] \\ &\quad + f_{j+1}c_j^2[2F(1 - 2c_jG) - 2c_jF^2] \\ &\quad + k_jc_j^2[G^2 + 2FG] \\ &\quad + k_{j+1}c_j^2[2FG + F^2]. \end{aligned}$$

If  $x = x_j$ , then  $F = 0$ , and in the first line the expression in the brackets  $[\cdot \cdot \cdot]$  reduces to

$$2G(1 + c_jG) = 2(x_j - x_{j+1}) \left( 1 + \frac{x_j - x_{j+1}}{x_{j+1} - x_j} \right) = 0.$$

In the second and fourth lines we obtain zero. There remains

$$q_j'(x_j) = k_jc_j^2(x_{j+1} - x_j)^2 = k_j.$$

Similarly, if  $x = x_{j+1}$ , then  $G = 0$  and

$$\begin{aligned} q_j'(x_{j+1}) &= f_{j+1}c_j^2[2(x_{j+1} - x_j) - 2c_j(x_{j+1} - x_j)^2] \\ &\quad + k_{j+1}c_j^2(x_{j+1} - x_j)^2 \\ &= 0 + k_{j+1} \cdot 1 = k_{j+1}. \end{aligned}$$

This verifies (5).

4. This derivation is simple and straightforward.
8.  $p_2(x) = x^2$ .  $[f(x) - p_2(x)]' = 4x^3 - 2x = 0$  gives the points of maximum deviation  $x = \pm 1/\sqrt{2}$  and by inserting this, the maximum deviation itself,

$$|f(1/\sqrt{2}) - p_2(1/\sqrt{2})| = \left| \frac{1}{4} - \frac{1}{2} \right| = \frac{1}{4}.$$

For the spline  $g(x)$  we get, taking  $x \geq 0$ ,

$$[f(x) - g(x)]' = 4x^3 + 2x - 6x^2 = 0.$$

A solution is  $x = 1/2$ . The corresponding maximum deviation is

$$f\left(\frac{1}{2}\right) - g\left(\frac{1}{2}\right) = \frac{1}{16} - \left(-\frac{1}{4} + 2 \cdot \frac{1}{8}\right) = \frac{1}{16},$$

which is merely 25% of the previous value.

10. We obtain

$$\begin{aligned} q_0 &= -\frac{3}{4}(x+2)^2 + \frac{3}{4}(x+2)^3 \\ &= 3 + 6x + \frac{15}{4}x^2 + \frac{3}{4}x^3 \\ q_1 &= \frac{3}{4}(x+1) + \frac{3}{2}(x+1)^2 - \frac{5}{4}(x+1)^3 \\ &= 1 - \frac{9}{4}x^2 - \frac{5}{4}x^3 \\ q_2 &= 1 - \frac{9}{4}x^2 + \frac{5}{4}x^3 \\ q_3 &= -\frac{3}{4}(x-1) + \frac{3}{2}(x-1)^2 - \frac{3}{4}(x-1)^3 \\ &= 3 - 6x + \frac{15}{4}x^2 - \frac{3}{4}x^3. \end{aligned}$$

12.  $n = 3, h = 2$ , so that (14) is

$$k_0 + 4k_1 + k_2 = \frac{3}{2}(f_2 - f_0) = 60$$

$$k_1 + 4k_2 + k_3 = \frac{3}{2}(f_3 - f_1) = 48.$$

Since  $k_0 = 0$  and  $k_3 = -12$ , the solution is  $k_1 = 12, k_2 = 12$ .

In (13) with  $j = 0$  we have  $a_{00} = f_0 = 1, a_{01} = k_0 = 0,$

$$a_{02} = \frac{3}{4}(9 - 1) - \frac{1}{2}(12 + 0) = 0$$

$$a_{03} = \frac{2}{8}(1 - 9) + \frac{1}{4}(12 + 0) = 1.$$

From this and, similarly, from (13) with  $j = 1$  and  $j = 2$  we get the spline  $g(x)$  consisting of the three polynomials (see the figure)

$$q_0(x) = 1 + x^3 \quad (0 \leq x \leq 2)$$

$$q_1(x) = 9 + 12(x - 2) + 6(x - 2)^2 - 2(x - 2)^3 = 25 - 36x + 18x^2 - 2x^3 \quad (2 \leq x \leq 4)$$

$$q_2(x) = 41 + 12(x - 4) - 6(x - 4)^2 = -103 + 60x - 6x^2 \quad (4 \leq x \leq 6).$$

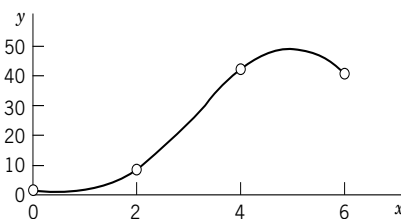

Section 19.4. Spline in Problem 12

14.  $q_0(x) = x^3,$   
 $q_1(x) = 1 + 3(x - 1) + 3(x - 1)^2 - (x - 1)^3,$   
 $q_2(x) = 6 + 6(x - 2) - 2(x - 2)^3$

16.  $3x/\pi - 4x^3/\pi^3$

18. The purpose of the experiment is to see that the advantage of the spline over the polynomial increases drastically with  $m$ . The greatest deviation of  $p_m$  occurs at the ends. Formulas for the  $p_m$  as a CAS will give them are

$$p_4(x) = 1 - \frac{5}{4}x^2 + \frac{1}{4}x^4$$

$$p_6(x) = 1 - \frac{49}{36}x^2 + \frac{7}{18}x^4 - \frac{1}{36}x^6$$

$$p_8(x) = 1 - \frac{205}{144}x^2 + \frac{91}{192}x^4 - \frac{5}{96}x^6 + \frac{1}{576}x^8$$

and so on.

20. Team Project.

(b)  $x(t) = \frac{1}{2}t + \frac{5}{2}t^2 - 2t^3, y(t) = \frac{1}{2}t + (\frac{1}{4}\sqrt{3} - 1)t^2 + (\frac{1}{2} - \frac{1}{4}\sqrt{3})t^3$

(c)  $x(t) = t + 2t^2 - 2t^3, y(t) = t + (\frac{1}{2}\sqrt{3} - 2)t^2 + (1 - \frac{1}{2}\sqrt{3})t^3$

Note that the tangents in (b) and (c) are not parallel.

## SECTION 19.5. Numeric Integration and Differentiation, page 817

**Purpose.** Evaluation of integrals of empirical functions, functions not integrable by elementary methods, etc.

**Main Content, Important Concepts**

- Simpson's rule (7) (most important), error (8), (10)
- Trapezoidal rule (2), error (4), (5)
- Gaussian integration
- Degree of precision of an integration formula
- Adaptive integration with Simpson's rule (Example 6)
- Numerical differentiation

**Short Courses.** Discuss and apply Simpson's rule.

**Comments on Content**

The range of numerical integration includes empirical functions, as measured or recorded in experiments, functions that cannot be integrated by the usual methods, or functions that can be integrated by those methods but lead to expressions whose computational evaluation would be more complicated than direct numerical integration of the integral itself.

Simpson's rule approximates the integrand by quadratic parabolas. Approximations by higher order polynomials are possible, but lead to formulas that are generally less practical.

Numerical differentiation can sometimes be avoided by changing the mathematical model of the problem.

**SOLUTIONS TO PROBLEM SET 19.5, page 828**

2. Let  $A_j$  and  $B_j$  be lower and upper bounds for  $f$  in the  $j$ th subinterval. Then  $A \leq J \leq B$ , where  $A = h\sum A_j$  and  $B = h\sum B_j$ . In Example 1 the maximum and minimum of the integrand in a subinterval occur at the ends. Hence we obtain  $A$  and  $B$  by choosing the left and right endpoints, respectively, of each subinterval instead of the midpoints as in (1). *Answer:*  $0.714 \leq J \leq 0.778$ , rounded to 3S.

4. The first term,  $1/20$ , results from  $(1 + \frac{1}{2}) \cdot 0.1/3$ . We obtain

$$\frac{1}{20} + \frac{2}{15} \sum_{j=1}^5 \frac{1}{0.9 + 0.2j} + \frac{1}{15} \sum_{j=1}^4 \frac{1}{1 + 0.2j} = 0.6931502.$$

The 7S-exact value is 0.6931472.

6. 1.5576070 (8S-exact value 1.5574077)

8. 0.9080057 (8S-exact 0.9084218)

10.  $J_{h/2} + \epsilon_{h/2} = 1.5574211 - 0.0000124 = 1.5574087$  (8S-exact 1.5574077)

12.  $J_{h/2} + \epsilon_{h/2} = 0.9083952 + 0.0000260 = 0.9084212$

14. From (5) and the values in Prob. 13 we obtain

$$0.94583 + \frac{1}{3}(0.94583 - 0.94508) = 0.94608$$

which is exact to 5S.

16. From (10) and Prob. 15 we obtain

$$0.94608693 + \frac{1}{15}(0.94608693 - 0.94614588) = 0.94608300$$

which is exact to 6S, the error being 7 units of the 8th decimal.

18. We obtain

$$\frac{1}{24} \left( 4 \sum_{j=1}^5 \sin \left( \frac{1}{4}j - \frac{1}{8} \right)^2 + 2 \sum_{k=1}^4 \sin \frac{1}{16}k^2 + \sin \frac{25}{16} \right) = 0.545941.$$

The exact 6S-value is 0.545962.



20.  $h|\frac{1}{2}\epsilon_0 + \epsilon_1 + \dots + \epsilon_{n-1} + \frac{1}{2}\epsilon_n| \leq [(b-a)/n]nu = (b-a)u$ . This is similar to the corresponding proof for Simpson's rule given in the text.

22. Since the cosine is even, we can take terms together,

$$\int_0^{\pi/2} \cos x \, dx = \frac{1}{2} \int_{-\pi/2}^{\pi/2} \cos x \, dx = \frac{\pi}{4} \int_{-1}^1 \cos \frac{1}{2}\pi t \, dt$$

$$\approx \frac{\pi}{4} [2A_1 \cos \frac{1}{2}\pi t_1 + 2A_2 \cos \frac{1}{2}\pi t_2 + A_3 \cdot 1] = 1.00000 \, 00552.$$

24.  $x = (t + 1)/1.6$  gives  $x = 0$  when  $t = -1$  and  $x = 1.25$  when  $t = 1$ . Also  $dx = dt/1.6$ . The computation gives 0.5459627. The 7S-exact value is 0.5459623. This is the value of the Fresnel integral  $S(x)$  at  $x = 1.25$ .

26. **Team Project.** The factor  $2^4 = 16$  comes in because we have replaced  $h$  by  $\frac{1}{4}h$ , giving for  $h^2$  now  $(\frac{1}{4}h)^2 = \frac{1}{16}h^2$ . In the next step (with  $h/8$ ) the error  $\epsilon_{43}$  has the factor  $1/(2^6 - 1) = \frac{1}{63}$ , etc.

For  $f(x) = e^{-x}$  the table of  $J$  and  $\epsilon$  values is

|                     |                             |                     |                             |                     |
|---------------------|-----------------------------|---------------------|-----------------------------|---------------------|
| $J_{11} = 1.135335$ | $\epsilon_{21} = -0.066596$ |                     |                             |                     |
| $J_{21} = 0.935547$ | $\epsilon_{31} = -0.017648$ | $J_{22} = 0.868951$ |                             |                     |
| $J_{31} = 0.882604$ |                             | $J_{32} = 0.864956$ | $\epsilon_{32} = -0.000266$ |                     |
|                     |                             |                     |                             | $J_{33} = 0.864690$ |

Note that  $J_{33}$  is exact to 4D.

For  $f(x) = \frac{1}{4}\pi x^4 \cos \frac{1}{4}\pi x$  the table is

|                     |                            |                    |                            |                            |
|---------------------|----------------------------|--------------------|----------------------------|----------------------------|
| $J_{11} = 0$        | $\epsilon_{21} = 0.185120$ |                    |                            |                            |
| $J_{21} = 0.555360$ | $\epsilon_{31} = 0.168597$ | $J_{22} = 0.74048$ |                            |                            |
| $J_{31} = 1.06115$  | $\epsilon_{41} = 0.049142$ | $J_{32} = 1.22975$ | $\epsilon_{32} = 0.03262$  | $J_{33} = 1.26236$         |
| $J_{41} = 1.20857$  |                            | $J_{42} = 1.25771$ | $\epsilon_{42} = 0.001864$ | $\epsilon_{43} = -0.00004$ |
|                     |                            |                    | $J_{43} = 1.25958$         | $J_{44} = 1.25953$         |

Note that  $J_{44}$  is exact to 5D.

28. 0.240, which is not exact. It can be shown that the error term of the present formula is  $h^3 f^{(4)}(\xi)/12$ , whereas that of (15) is  $h^4 f^{(5)}(\xi)/30$ , where  $x_2 - h < \xi < x_2 + h$ . In our case this gives the exact value  $0.240 + 0.016 = 0.256$  and  $0.256 + 0 = 0.256$ , respectively.

30. Differentiating (14) in Sec. 19.3 with respect to  $r$  and using  $dr = dx/h$  we get

$$\frac{df(x)}{dr} = hf'(x) \approx \Delta f_0 + \frac{2r-1}{2!} \Delta^2 f_0 + \frac{3r^2-6r+2}{3!} \Delta^3 f_0 + \dots$$

Now  $x = x_0$  gives  $r = (x - x_0)/h = 0$  and the desired formula follows.

**SOLUTIONS TO CHAP. 19 REVIEW QUESTIONS AND PROBLEMS, page 830**

16.  $-0.35287 \cdot 10^0, 0.12748 \cdot 10^4, -0.61400 \cdot 10^{-2}, 0.24948 \cdot 10^2, 0.33333 \cdot 10^0, 0.12143 \cdot 10^2$

18. 8.2586, 8.258, 9.9, impossible

20. 199.98, 0.02; 199.98, 0.020002

22.  $-7.9475 \leq d \leq -7.9365$

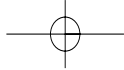

$$24. \epsilon_r(\tilde{a}^2) = \frac{a^2 - \tilde{a}^2}{a^2} = \frac{a + \tilde{a}}{a} \cdot \frac{a - \tilde{a}}{a} \approx \frac{2a}{a} \cdot \frac{a - \tilde{a}}{a} = 2\epsilon_r(\tilde{a})$$

26. Because  $|g'(x)|$  is small (0.038) near the solution 0.739085.

28. 0.739. As mentioned before, this method is good for starting but should not be used once one is close to the solution.

30.  $2 - 3x + 2x^3$  if  $-1 \leq x \leq 1$ ,  $1 + 3(x - 1) + 6(x - 1)^2 - (x - 1)^3$   
if  $1 \leq x \leq 3$ ,  $23 + 15(x - 3) - (x - 3)^3$  if  $3 \leq x \leq 5$

32.  $J_{0.5} = 0.90266$ ,  $J_{0.25} = 0.90450$ ,  $\epsilon_{0.25} = 0.00012$

## CHAPTER 20 Numeric Linear Algebra

### SECTION 20.1. Linear Systems: Gauss Elimination, page 833

**Purpose.** To explain the Gauss elimination, which is a solution method for linear systems of equations by systematic elimination (reduction to triangular form).

#### Main Content, Important Concepts

- Gauss elimination, back substitution
- Pivot equation, pivot, choice of pivot
- Operations count, order [e.g.,  $O(n^3)$ ]

#### Comments on Content

This section is independent of Chap. 7 on matrices (in particular, independent of Sec. 7.3, where the Gauss elimination is also considered).

Gauss's method and its variants (Sec. 20.2) are the most important solution methods for those systems (with matrices that do not have too many zeros).

The Gauss–Jordan method (Sec. 20.2) is less practical because it requires more operations than the Gauss elimination.

Cramer's rule (Sec. 7.7) would be totally impractical in numeric work, even for systems of modest size.

### SOLUTIONS TO PROBLEM SET 20.1, page 839

2.  $x_1 = 0.65x_2$ ,  $x_2$  arbitrary. Both equations represent the same straight line.
4.  $x_1 = 0$ ,  $x_2 = -3$
6.  $x_1 = (30.6 + 15.48x_2)/25.38$ ,  $x_2$  arbitrary
8. No solution; the matrix obtained at the end is

$$\begin{bmatrix} 5 & 3 & 1 & 2 \\ 0 & -4 & 8 & -3 \\ 0 & 0 & 0 & 5 \end{bmatrix}.$$

10.  $x_1 = 0.5$ ,  $x_2 = -0.5$ ,  $x_3 = 3.5$
12.  $x_1 = 0.142857$ ,  $x_2 = 0.692308$ ,  $x_3 = -0.173913$
14.  $x_1 = 1.05$ ,  $x_2 = 0$ ,  $x_3 = -0.45$ ,  $x_4 = 0.5$
16. **Team Project.** (a) (i)  $a \neq 1$  to make  $D = a - 1 \neq 0$ ; (ii)  $a = 1$ ,  $b = 3$ ; (iii)  $a = 1$ ,  $b \neq 3$ .  
 (b)  $x_1 = \frac{1}{2}(3x_3 - 1)$ ,  $x_2 = \frac{1}{2}(-5x_3 + 7)$ ,  $x_3$  arbitrary is the solution of the first system. The second system has no solution.  
 (c)  $\det \mathbf{A} = 0$  can change to  $\det \mathbf{A} \neq 0$  because of roundoff.  
 (d)  $(1 - 1/\epsilon)x_2 = 2 - 1/\epsilon$  eventually becomes  $x_2/\epsilon \approx 1/\epsilon$ ,  $x_2 = 1$ ,  $x_1 = (1 - x_2)/\epsilon \approx 0$ . The exact solution is  $x_1 = 1/(1 - \epsilon)$ ,  $x_2 = (1 - 2\epsilon)/(1 - \epsilon)$ . We obtain it if we take  $x_1 + x_2 = 2$  as the pivot equation.  
 (e) The exact solution is  $x_1 = 1$ ,  $x_2 = -4$ . The 3-digit calculation gives  $x_2 = -4.5$ ,  $x_1 = 1.27$  without pivoting and  $x_2 = -6$ ,  $x_1 = 2.08$  with pivoting. This shows that

3S is simply not enough. The 4-digit calculations give  $x_2 = -4.095$ ,  $x_1 = 1.051$  without pivoting and the exact result  $x_2 = -4$ ,  $x_1 = 1$  with pivoting.

### SECTION 20.2. Linear Systems: LU-Factorization, Matrix Inversion, page 840

**Purpose.** To discuss Doolittle's, Crout's, and Cholesky's methods, three methods for solving linear systems that are based on the idea of writing the coefficient matrix as a product of two triangular matrices ("LU-factorization"). Furthermore, we discuss matrix inversion by the Gauss–Jordan elimination.

#### Main Content, Important Concepts

Doolittle's and Crout's methods for arbitrary square matrices

Cholesky's method for positive definite symmetric matrices

Numerical matrix inversion

**Short Courses.** Doolittle's method and the Gauss–Jordan elimination.

#### Comment on Content

L suggests "lower triangular" and U "upper triangular." For Doolittle's method, these are the same as the matrix of the multipliers and of the triangular system in the Gauss elimination.

The point is that in the present methods, one solves one equation at a time, no systems.

### SOLUTIONS TO PROBLEM SET 20.2, page 844

$$2. \begin{bmatrix} 1 & 0 \\ 1.5 & 1 \end{bmatrix} \begin{bmatrix} 2 & 9 \\ 0 & -18.5 \end{bmatrix}, \begin{matrix} x_1 = -2 \\ x_2 = 5 \end{matrix}$$

$$4. \begin{bmatrix} 1 & 0 & 0 \\ -1 & 1 & 0 \\ \frac{1}{2} & \frac{1}{2} & 1 \end{bmatrix} \begin{bmatrix} 2 & 1 & 2 \\ 0 & 3 & 3 \\ 0 & 0 & -\frac{9}{2} \end{bmatrix}, \begin{matrix} x_1 = 4 \\ x_2 = 8 \\ x_3 = -8 \end{matrix}$$

$$6. \begin{bmatrix} 1 & 0 & 0 \\ -1/3 & 1 & 0 \\ -2/3 & 4/5 & 1 \end{bmatrix} \begin{bmatrix} -3/2 & -7/2 & -52/5 \\ 0 & -25/6 & -1/6 \\ 0 & 0 & -21/5 \end{bmatrix}, \begin{matrix} x_1 = -0.2 \\ x_2 = 2.4 \\ x_3 = -2.8 \end{matrix}$$

**8. Team Project.** (a) The formulas for the entries of  $\mathbf{L} = [l_{jk}]$  and  $\mathbf{U} = [u_{jk}]$  are

$$l_{j1} = a_{j1} \quad j = 1, \dots, n$$

$$u_{1k} = \frac{a_{1k}}{l_{11}} \quad k = 2, \dots, n$$

$$l_{jk} = a_{jk} - \sum_{s=1}^{k-1} l_{js}u_{sk} \quad j = k, \dots, n; \quad k \geq 2$$

$$u_{jk} = \frac{1}{l_{jj}} \left( a_{jk} - \sum_{s=1}^{j-1} l_{js}u_{sk} \right) \quad k = j+1, \dots, n; \quad j \geq 2.$$

(b) The factorizations and solutions are

$$\begin{bmatrix} 3 & 0 \\ 15 & 1 \end{bmatrix} \begin{bmatrix} 1 & 2/3 \\ 0 & 1 \end{bmatrix}, \mathbf{y} = \begin{bmatrix} 76/15 \\ 13/10 \end{bmatrix}, \mathbf{x} = \begin{bmatrix} 4.2 \\ 1.3 \end{bmatrix}$$

and for Prob. 7

$$\begin{bmatrix} 3 & 0 & 0 \\ 18 & -6 & 0 \\ 9 & -54 & -3 \end{bmatrix} \begin{bmatrix} 1 & 3 & 2 \\ 0 & 1 & -\frac{1}{2} \\ 0 & 0 & 1 \end{bmatrix}, \mathbf{y} = \begin{bmatrix} 23/30 \\ 1/30 \\ 1/5 \end{bmatrix}, \mathbf{x} = \begin{bmatrix} -1/30 \\ 2/15 \\ 1/5 \end{bmatrix}.$$

(c) The three factorizations are

$$\begin{bmatrix} 1 & 0 & 0 \\ -4 & 1 & 0 \\ 2 & 4/3 & 1 \end{bmatrix} \begin{bmatrix} 1 & -4 & 2 \\ 0 & 9 & 12 \\ 0 & 0 & 4 \end{bmatrix} \quad (\text{Doolittle})$$

$$\begin{bmatrix} 1 & 0 & 0 \\ -4 & 9 & 0 \\ 2 & 12 & 4 \end{bmatrix} \begin{bmatrix} 1 & -4 & 2 \\ 0 & 1 & 4/3 \\ 0 & 0 & 1 \end{bmatrix} \quad (\text{Crout})$$

$$\begin{bmatrix} 1 & 0 & 0 \\ -4 & 3 & 0 \\ 2 & 4 & 2 \end{bmatrix} \begin{bmatrix} 1 & -4 & 2 \\ 0 & 3 & 4 \\ 0 & 0 & 2 \end{bmatrix} \quad (\text{Cholesky}).$$

(d) For fixing the notation, for  $n = 4$  we have

$$\mathbf{A} = \mathbf{LU} = \begin{bmatrix} a_1 & c_1 & 0 & 0 \\ b_2 & a_2 & c_2 & 0 \\ 0 & b_3 & a_3 & c_3 \\ 0 & 0 & b_4 & a_4 \end{bmatrix} = \begin{bmatrix} \alpha_1 & 0 & 0 & 0 \\ b_2 & \alpha_2 & 0 & 0 \\ 0 & b_3 & \alpha_3 & 0 \\ 0 & 0 & b_4 & \alpha_4 \end{bmatrix} \begin{bmatrix} 1 & \gamma_1 & 0 & 0 \\ 0 & 1 & \gamma_2 & 0 \\ 0 & 0 & 1 & \gamma_3 \\ 0 & 0 & 0 & 1 \end{bmatrix}$$

where

$$\begin{aligned} \alpha_1 &= a_1, & \alpha_j &= a_j - b_j \gamma_{j-1}, & j &= 2, \dots, n \\ \gamma_1 &= c_1/\alpha_1, & \gamma_j &= c_j/\alpha_j, & j &= 2, \dots, n-1 \end{aligned}$$

(e) If  $\mathbf{A}$  is symmetric

$$10. \begin{bmatrix} 0.2 & 0 & 0 \\ 0 & 0.8 & 0 \\ 0.6 & 0.4 & 0.2 \end{bmatrix} \begin{bmatrix} 0.2 & 0 & 0.6 \\ 0 & 0.8 & 0.4 \\ 0 & 0 & 0.2 \end{bmatrix} \begin{aligned} x_1 &= 5 \\ x_2 &= -2.5 \\ x_3 &= 10 \end{aligned}$$

$$12. \begin{bmatrix} 1 & 0 & 0 & 0 \\ -1 & 2 & 0 & 0 \\ 3 & -1 & 3 & 0 \\ 2 & 0 & -1 & 4 \end{bmatrix} \begin{bmatrix} 1 & -1 & 3 & 2 \\ 0 & 2 & -1 & 0 \\ 0 & 0 & 3 & -1 \\ 0 & 0 & 0 & 4 \end{bmatrix} \begin{aligned} x_1 &= 4 \\ x_2 &= -6 \\ x_3 &= 8 \\ x_4 &= -2 \end{aligned}$$

16. The inverse is

$$\frac{1}{9} \begin{bmatrix} 2 & -2 & 1 \\ 1 & 2 & 2 \\ 2 & 1 & -2 \end{bmatrix} = \frac{1}{9} \mathbf{A}^T.$$

Hence  $\frac{1}{9}\mathbf{A}$  is orthogonal.

18. The inverse is

$$\begin{bmatrix} \frac{57}{35} & -\frac{26}{35} & \frac{6}{35} \\ \frac{1}{105} & -\frac{26}{105} & -\frac{8}{105} \\ -\frac{5}{21} & \frac{4}{21} & -\frac{2}{21} \end{bmatrix}.$$

20.  $\det \mathbf{A} = 0$  as given, but rounding makes  $\det \mathbf{A} \neq 0$  and may completely change the situation with respect to existence of solutions of linear systems, a point to be watched for when using a CAS. In the present case we get (a)  $-0.00000035$ , (b)  $-0.00001998$ , (c)  $-0.00028189$ , (d)  $0.002012$ , (e)  $0.00020000$ .

### SECTION 20.3. Linear Systems: Solution by Iteration, page 845

**Purpose.** To familiarize the student with the idea of solving linear systems by iteration, to explain in what situations that is practical, and to discuss the most important method (Gauss–Seidel iteration) and its convergence.

#### Main Content, Important Concepts

Distinction between direct and indirect methods

Gauss–Seidel iteration, its convergence, its range of applicability

Matrix norms

Jacobi iteration

**Short Courses.** Gauss–Seidel iteration only.

#### Comments on Content

The Jacobi iteration appeals by its simplicity but is of limited practical value.

A word on the frequently occurring sparse matrices may be good. For instance, we have about 99.5% zeros in solving the Laplace equation in two dimensions by using a  $1000 \times 1000$  grid and the usual five-point pattern (Sec. 21.4).

### SOLUTIONS TO PROBLEM SET 20.3, page 850

2. The eigenvalues of  $\mathbf{I} - \mathbf{A}$  are 0.5, 0.5,  $-1$ . Here  $\mathbf{A}$  is  $\frac{1}{2}$  times the coefficient matrix of the given system; thus,

$$\mathbf{I} - \mathbf{A} = \begin{bmatrix} 0 & -\frac{1}{2} & -\frac{1}{2} \\ -\frac{1}{2} & 0 & -\frac{1}{2} \\ -\frac{1}{2} & -\frac{1}{2} & 0 \end{bmatrix}.$$

4. Row 1 becomes Row 3, Row 2 becomes Row 1, and Row 3 becomes Row 2. The exact solution is  $x_1 = 0.5$ ,  $x_2 = -2.5$ ,  $x_3 = 4.0$ . The choice of  $\mathbf{x}_0$  is of much less influence than one would expect. We obtain for  $\mathbf{x}_0 = [0 \ 0 \ 0]^T$

- 1,  $[0, -1.75000, 3.89286]$
- 2,  $[0.350000, -2.45715, 3.99388]$
- 3,  $[0.491430, -2.49755, 3.99966]$
- 4,  $[0.499510, -2.49987, 3.99998]$
- 5,  $[0.499974, -2.50000, 4.00000]$
- 6,  $[0.500000, -2.50000, 4.00000]$

for  $\mathbf{x}_0 = [1 \ 1 \ 1]^T$

- 1,  $[-0.200000, -1.88333, 3.91190]$
- 2,  $[0.376666, -2.46477, 3.99497]$
- 3,  $[0.492954, -2.49798, 3.99971]$
- 4,  $[0.499596, -2.49988, 3.99998]$
- 5,  $[0.499976, -2.50000, 4.00000]$
- 6,  $[0.500000, -2.50000, 4.00000]$

for  $\mathbf{x}_0 = [10 \ 10 \ 10]^T$

- 1,  $[-2, -3.08333, 4.08333]$
- 2,  $[0.616666, -2.53333, 4.00476]$
- 3,  $[0.506666, -2.50190, 4.00027]$
- 4,  $[0.500380, -2.50010, 4.00001]$
- 5,  $[0.500020, -2.50000, 4.00000]$
- 6,  $[0.500000, -2.50000, 4.00000]$

and for  $\mathbf{x}_0 = [100 \ 100 \ 100]^T$

- 1,  $[-20, -15.0833, 5.79761]$
- 2,  $[3.01666, -3.21905, 4.10271]$
- 3,  $[0.643810, -2.54108, 4.00587]$
- 4,  $[0.508216, -2.50235, 4.00034]$
- 5,  $[0.500470, -2.50013, 4.00001]$
- 6,  $[0.500026, -2.50000, 4.00000]$

The spectral radius of  $\mathbf{C}$  (and its only nonzero eigenvalue) is  $2/35 = 0.057$ .

6. The exact solution  $\mathbf{x} = [3 \ -9 \ 6]^T$  is reached at Step 8 rather quickly owing to the fact that the spectral radius of  $\mathbf{C}$  is 0.125, hence rather small; here

$$\mathbf{C} = \begin{bmatrix} 0 & 1/4 & 0 \\ 0 & 1/16 & 1/4 \\ 0 & 1/64 & 1/16 \end{bmatrix}.$$

8. Interchange the first equation and the last equation. Then the exact solution  $-2.5, 2, 4.5$  is reached at Step 11, the spectral radius of

$$\mathbf{C} = \begin{bmatrix} 0 & -\frac{1}{4} & -\frac{1}{8} \\ 0 & \frac{1}{24} & -\frac{5}{16} \\ 0 & \frac{1}{5} & \frac{1}{10} \end{bmatrix}$$

being  $1/\sqrt{15} = 0.258199$ . (The eigenvalues are complex conjugates, and the third eigenvalue is 0, as always for the present  $\mathbf{C}$ .)

10. In (a) we obtain

$$\begin{aligned} \mathbf{C} &= -(\mathbf{I} + \mathbf{L})^{-1}\mathbf{U} \\ &= -\begin{bmatrix} 1 & 0 & 0 \\ -0.1 & 1 & 0 \\ -0.09 & -0.1 & 1 \end{bmatrix} \begin{bmatrix} 0 & 0.1 & 0.1 \\ 0 & 0 & 0.1 \\ 0 & 0 & 0 \end{bmatrix} \\ &= \begin{bmatrix} 0 & -0.100 & -0.100 \\ 0 & 0.010 & -0.090 \\ 0 & 0.009 & 0.019 \end{bmatrix} \end{aligned}$$

and  $\|\mathbf{C}\| = 0.2 < 1$  by (11), which implies convergence by (8).

In (b) we have

$$\begin{aligned} \begin{bmatrix} 1 & 1 & 10 \\ 10 & 1 & 1 \\ 1 & 10 & 1 \end{bmatrix} &= (\mathbf{I} + \mathbf{L}) + \mathbf{U} \\ &= \begin{bmatrix} 1 & 0 & 0 \\ 10 & 1 & 0 \\ 1 & 10 & 1 \end{bmatrix} + \begin{bmatrix} 0 & 1 & 10 \\ 0 & 0 & 1 \\ 0 & 0 & 0 \end{bmatrix}. \end{aligned}$$

From this we compute

$$\begin{aligned} \mathbf{C} = -(\mathbf{I} + \mathbf{L})^{-1}\mathbf{U} &= -\begin{bmatrix} 1 & 0 & 0 \\ -10 & 1 & 0 \\ 99 & -10 & 1 \end{bmatrix} \begin{bmatrix} 0 & 1 & 10 \\ 0 & 0 & 1 \\ 0 & 0 & 0 \end{bmatrix} \\ &= -\begin{bmatrix} 0 & 1 & 10 \\ 0 & -10 & -99 \\ 0 & 99 & 980 \end{bmatrix} \\ &= \begin{bmatrix} 0 & -1 & -10 \\ 0 & 10 & 99 \\ 0 & -99 & -980 \end{bmatrix}. \end{aligned}$$



Developing the characteristic determinant of  $c$  by its first column, we obtain

$$-\lambda \begin{vmatrix} -\lambda + 10 & 99 \\ -99 & -\lambda - 980 \end{vmatrix} = -\lambda(\lambda^2 + 970\lambda + 1)$$

which shows that one of the eigenvalues is greater than 1 in absolute value, so that we have divergence. In fact,  $\lambda = -0, 0.001$  and  $-970$ , approximately.

$$12. \begin{bmatrix} 1 \\ 1 \\ 1 \end{bmatrix}, \begin{bmatrix} 5.5 \\ -10.75 \\ 8.5 \end{bmatrix}, \begin{bmatrix} 2.5625 \\ -7.75 \\ 5.5625 \end{bmatrix}, \begin{bmatrix} 3.3125 \\ -9.21875 \\ 6.3125 \end{bmatrix}, \begin{bmatrix} 2.94531 \\ -8.84375 \\ 5.94531 \end{bmatrix}, \begin{bmatrix} 3.03906 \\ -9.02734 \\ 6.03906 \end{bmatrix}.$$

Step 5 of the Gauss-Seidel iteration gives the better result

$$[2.99969 \quad -9.00015 \quad 5.99996]^T. \quad \text{Exact: } [3 \quad -9 \quad 6]^T.$$

$$14. \begin{bmatrix} 1 \\ 1 \\ 1 \end{bmatrix}, \begin{bmatrix} -1.8125 \\ 2.58333 \\ 1.7 \end{bmatrix}, \begin{bmatrix} -2.29583 \\ 2.81875 \\ 3.95 \end{bmatrix}, \begin{bmatrix} -2.63594 \\ 2.14931 \\ 4.33667 \end{bmatrix}, \begin{bmatrix} -2.51691 \\ 2.07710 \\ 4.60875 \end{bmatrix}, \begin{bmatrix} -2.53287 \\ 1.96657 \\ 4.51353 \end{bmatrix}$$

Step 5 of the Gauss-Seidel iteration gives the more accurate result

$$[-2.49475 \quad 1.99981 \quad 4.49580]^T. \quad \text{Exact: } [-2.5 \quad 2 \quad 4.5]^T.$$

$$16. \sqrt{193} = 13.89, 12, 12$$

$$18. \sqrt{151} = 12.29, 13 \text{ (column sum norm), } 11 \text{ (row sum norm)}$$

$$20. \sqrt{537} = 23.17, 28 \text{ (column sum norm), } 31 \text{ (row sum norm)}$$

#### SECTION 20.4. Linear Systems: Ill-Conditioning, Norms, page 851

**Purpose.** To discuss ill-conditioning quantitatively in terms of norms, leading to the condition number and its role in judging the effect of inaccuracies on solutions.

##### Main Content, Important Concepts

Ill-conditioning, well-conditioning

Symptoms of ill-conditioning

Residual

Vector norms

Matrix norms

Condition number

Bounds for effect of inaccuracies of coefficients on solutions

##### Comment on Content

Reference [E9] in App. 1 gives some help when  $\mathbf{A}^{-1}$ , needed in  $\kappa(\mathbf{A})$ , is unknown (as is the case in practice).

#### SOLUTIONS TO PROBLEM SET 20.4, page 858

$$2. 9.6, \sqrt{65.6} = 8.099, 8, [0.05 \quad -0.15 \quad 0 \quad 1]^T$$

$$4. 1, 1, 1, \text{ the given vector is a unit vector.}$$

6.  $210, \sqrt{17774} = 133.3, 119, [16/119 \ 21/119 \ 54/119 \ -1]^T$

8.  $6, \sqrt{18}, 3, [1 \ 0 \ 0 \ -1 \ 0]^T$

10.  $\mathbf{A}^{-1} = \begin{bmatrix} -0.2 & 0.4 \\ 0.1 & 0.3 \end{bmatrix}$ ,  $\|\mathbf{A}\|_1 = 6$ ,  $\|\mathbf{A}^{-1}\|_1 = 0.7$ ,  $\kappa = 4.2$ . The matrix is well-conditioned.

12.  $\mathbf{A}^{-1} = \begin{bmatrix} 1/\sqrt{3} & 1 \\ 0 & -1/\sqrt{3} \end{bmatrix}$ ,  $\kappa = (3 + \sqrt{3})(1 + 1/\sqrt{3}) = 4 + 2\sqrt{3}$

Well-conditioned.

14.  $\mathbf{A}$  is the  $4 \times 4$  Hilbert matrix times 21. Its inverse is

$$\mathbf{A}^{-1} = \frac{1}{21} \begin{bmatrix} 16 & -120 & 240 & -140 \\ -120 & 1200 & -2700 & 1680 \\ 240 & -2700 & 6480 & -4200 \\ -140 & 1680 & -4200 & 2800 \end{bmatrix}.$$

This gives the condition number (in both norms, since  $\mathbf{A}$  and  $\mathbf{A}^{-1}$  are symmetric)

$$\kappa = 43.75 \cdot \frac{13620}{21} = 28375.000$$

showing that  $\mathbf{A}$  is very ill-conditioned.

16.  $\|\mathbf{Ax}\|_\infty = 4.4 < 1.2 \cdot 5 = 6$

20.  $[1 \ 1]^T, [1.7 \ 1.5]^T, \kappa = 289$

22. By (12),  $1 = \|\mathbf{I}\| = \|\mathbf{AA}^{-1}\| \leq \|\mathbf{A}\| \|\mathbf{A}^{-1}\| = \kappa(\mathbf{A})$ . For the Frobenius norm,  $\sqrt{n} = \|\mathbf{I}\| \leq \kappa(\mathbf{A})$ .

24. **Team Project.** (a) Formula (18a) is obtained from

$$\max |x_j| \leq \sum |x_k| = \|\mathbf{x}\|_1 \leq n \max |x_j| = n \|\mathbf{x}\|_\infty.$$

Equation (18b) follows from (18a) by division by  $n$ .

(b) To get the first inequality in (19a), consider the square of both sides and then take square roots on both sides. The second inequality in (19a) follows by means of the Cauchy-Schwarz inequality and a little trick worth remembering,

$$\sum |x_j| = \sum 1 \cdot |x_j| \leq \sqrt{\sum 1^2} \sqrt{\sum |x_j|^2} = \sqrt{n} \|\mathbf{x}\|_2.$$

To get (19b), divide (19a) by  $\sqrt{n}$ .

(c) Let  $\mathbf{x} \neq \mathbf{0}$ . Set  $\mathbf{x} = \|\mathbf{x}\|\mathbf{y}$ . Then  $\|\mathbf{y}\| = \|\mathbf{x}\|/\|\mathbf{x}\| = 1$ . Also,

$$\mathbf{Ax} = \mathbf{A}(\|\mathbf{x}\|\mathbf{y}) = \|\mathbf{x}\| \mathbf{Ay}$$

since  $\|\mathbf{x}\|$  is a number. Hence  $\|\mathbf{Ax}\|/\|\mathbf{x}\| = \|\mathbf{Ay}\|$ , and in (9), instead of taking the maximum over *all*  $\mathbf{x} \neq \mathbf{0}$ , since  $\|\mathbf{y}\| = 1$  we only take the maximum over all  $\mathbf{y}$  of norm 1. Write  $\mathbf{x}$  for  $\mathbf{y}$  to get (10) from this.

(d) These “axioms of a norm” follow from (3), which are the axioms of a vector norm.

**SECTION 20.5. Least Squares Method, page 859**

**Purpose.** To explain Gauss's least squares method of "best fit" of straight lines to given data  $(x_0, y_0), \dots, (x_n, y_n)$  and its extension to best fit of quadratic polynomials, etc.

**Main Content, Important Concepts**

Least squares method

Normal equations (4) for straight lines

Normal equations (8) for quadratic polynomials

**Short Courses.** Discuss the linear case only.

**Comment.** Normal equations are often *ill-conditioned*, so that results may be sensitive to round-off. For another (theoretically much more complicated) method, see Ref. [E5], p. 201.

**SOLUTIONS TO PROBLEM SET 20.5, page 862**

2. The line shifts upward; its slope *decreases* slightly. If you added, say,  $(5, 20)$ , the slope would *increase* slightly.
4.  $U = -5.20 + 53.4i$ . Estimate:  $R = 53.4 \Omega$ . Note that the line does not pass through the origin, as it should. This is typical.
6.  $F = -0.00206 + 0.50098s$ ; hence  $k = 0.50098$
8.  $y = 0.15 - 0.55x + 2.25x^2$
10.  $y = 1.790 - 0.433x + 0.105x^2$
12.  $b_0 n + b_1 \sum x_j + b_2 \sum x_j^2 + b_3 \sum x_j^3 = \sum y_j$   
 $b_0 \sum x_j + b_1 \sum x_j^2 + b_2 \sum x_j^3 + b_3 \sum x_j^4 = \sum x_j y_j$   
 $b_0 \sum x_j^2 + b_1 \sum x_j^3 + b_2 \sum x_j^4 + b_3 \sum x_j^5 = \sum x_j^2 y_j$   
 $b_0 \sum x_j^3 + b_1 \sum x_j^4 + b_2 \sum x_j^5 + b_3 \sum x_j^6 = \sum x_j^3 y_j$

16. **Team Project.** (a) We substitute  $F_m(x)$  into the integral and perform the square. This gives

$$\|f - F_m\|^2 = \int_a^b f^2 dx - 2 \sum_{j=0}^m a_j \int_a^b f y_j dx + \sum_{j=0}^m \sum_{k=0}^m a_j a_k \int_a^b y_j y_k dx.$$

This is a quadratic function in the coefficients. We take the partial derivative with respect to any one of them, call it  $a_l$ , and equate this derivative to zero. This gives

$$0 - 2 \int_a^b f y_l dx + 2 \sum_{j=0}^m a_j \int_a^b y_j y_l dx = 0.$$

Dividing by 2 and taking the first integral to the right gives the system of normal equations, with  $l = 0, \dots, m$ .

(b) In the case of a polynomial we have

$$\int_a^b y_j y_l dx = \int_a^b x^{j+l} dx$$

which can be readily integrated. In particular, if  $a = 0$  and  $b = 1$ , integration from 0 to 1 gives  $1/(j + l + 1)$ , and we obtain the **Hilbert matrix** as the coefficient matrix.

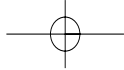

(c) In the case of an orthogonal system we see from (4), Sec. 5.8, with  $r(x) = 1$  (as for the Legendre polynomials, or with any weight function  $r(x)$  corresponding to the given system) and  $l$  instead of  $m$  that  $a_l = b_l / \|y_l\|^2$ .

### SECTION 20.6. Matrix Eigenvalue Problems: Introduction, page 863

**Purpose.** This section is a collection of concepts and a handful of theorems on matrix eigenvalues and eigenvectors that are frequently needed in numerics; some of them will be discussed in the remaining sections of the chapter and others can be found in more advanced or more specialized books listed in Part E of App. 1.

The section frees both the instructor and the student from the task of locating these matters in Chaps. 7 and 8, which contain much more material and should be consulted only if problems on one or another matter are wanted (depending on the background of the student) or if a proof might be of interest.

### SECTION 20.7. Inclusion of Matrix Eigenvalues, page 866

**Purpose.** To discuss theorems that give approximate values and error bounds of eigenvalues of general (square) matrices (Theorems 1, 2, 4, Example 2) and of special matrices (Theorem 6).

#### Main Content, Important Concepts

- Gerschgorin's theorem (Theorem 1)
- Sharpened Gerschgorin's theorem (Theorem 2)
- Gerschgorin's theorem improved by similarity (Example 2)
- Strict diagonal dominance (Theorem 3)
- Schur's inequality (Theorem 4), normal matrices
- Perron's theorem (Theorem 5)
- Collatz's theorem (Theorem 6)

**Short Courses.** Discuss Theorems 1 and 6.

#### Comments on Content

It is important to emphasize that one must always make sure whether or not a theorem applies to a given matrix. Some theorems apply to any real or complex square matrices whatsoever, whereas others are restricted to certain classes of matrices.

The exciting Gerschgorin's theorem was one of the early theorems on numerics for eigenvalues; it appeared in the *Bull. Acad. Sciences de l'URSS* (Classe mathém, 7-e série, Leningrad, 1931, p. 749), and shortly thereafter in the German *Zeitschrift für angewandte Mathematik und Mechanik*.

### SOLUTIONS TO PROBLEM SET 20.7, page 871

2. 5, 8, 9, radii  $2 \cdot 10^{-2}$ . Estimates of this kind can be useful when a matrix has been diagonalized numerically and some very small nonzero entries are left.
4.  $1 + i$ ,  $-3 + 2i$ ,  $4 - i$ , radii 0.8, 0.4, 0.3
6. 10, 6, 3, radii 0.3, 0.1, 0.2

8.  $\mathbf{T}$  with  $t_{11} = t_{22} = 1$ ,  $t = 34$  gives

$$\begin{aligned} \mathbf{T}^{-1}\mathbf{A}\mathbf{T} &= \begin{bmatrix} 1 & 0 & 0 \\ 0 & 1 & 0 \\ 0 & 0 & \frac{1}{34} \end{bmatrix} \begin{bmatrix} 10 & 0.1 & -0.2 \\ 0.1 & 6 & 0 \\ -0.2 & 0 & 3 \end{bmatrix} \begin{bmatrix} 1 & 0 & 0 \\ 0 & 1 & 0 \\ 0 & 0 & 34 \end{bmatrix} \\ &= \begin{bmatrix} 10 & 0.1 & -6.8 \\ 0.1 & 6 & 0 \\ -\frac{0.2}{34} & 0 & 3 \end{bmatrix}. \end{aligned}$$

Note that the disk with center 3 is still disjoint from that with center 10.

10. This is a “continuity proof.” Let  $S = D_1 \cup D_2 \cup \cdots \cup D_p$  without restriction, where  $D_j$  is the Gerschgorin disk with center  $a_{jj}$ . We write  $\mathbf{A} = \mathbf{B} + \mathbf{C}$ , where  $\mathbf{B} = \text{diag}(a_{jj})$  is the diagonal matrix with the main diagonal of  $\mathbf{A}$  as its diagonal. We now consider

$$\mathbf{A}_t = \mathbf{B} + t\mathbf{C} \quad \text{for } 0 \leq t \leq 1.$$

Then  $\mathbf{A}_0 = \mathbf{B}$  and  $\mathbf{A}_1 = \mathbf{A}$ . Now by algebra, the roots of the characteristic polynomial  $f_t(\lambda)$  of  $\mathbf{A}_t$  (that is, the eigenvalues of  $\mathbf{A}_t$ ) depend continuously on the coefficients of  $f_t(\lambda)$ , which in turn depend continuously on  $t$ . For  $t = 0$  the eigenvalues are  $a_{11}, \dots, a_{nn}$ . If we let  $t$  increase continuously from 0 to 1, the eigenvalues move continuously and, by Theorem 1, for each  $t$  lie in the Gerschgorin disks with centers  $a_{jj}$  and radii

$$tr_j \quad \text{where} \quad r_j = \sum_{k \neq j} |a_{jk}|.$$

Since at the end,  $S$  is disjoint from the other disks, the assertion follows.

12. Proofs follow readily from the definitions of these classes of matrices. This *normality* is of interest, since normal matrices have important properties; in particular, they have an orthonormal set of  $n$  eigenvectors, where  $n$  is the size of the matrix. See [B3], vol. I, pp. 268–274.

14. An example is

$$\mathbf{A} = \begin{bmatrix} 0 & 1 \\ 1 & 0 \end{bmatrix}.$$

The eigenvalues are  $-1$  and  $1$ , so that the entire spectrum lies on the circle. A similar-looking  $3 \times 3$  matrix or  $4 \times 4$  matrix, etc., can be constructed with some or all of its eigenvalues on the circle.

16.  $\sqrt{145.1} = 12.0457$

18.  $\mathbf{y} = [12 \ 13 \ 15]^T$ ,  $[13 \ 22 \ 18]^T$ ,  $[25 \ 35 \ 33]^T$ . This gives the inclusion intervals for the eigenvalue of maximum absolute value

$$12 \leq \lambda \leq 15, \quad 11 \leq \lambda \leq 18, \quad 35/3 \leq \lambda \leq 33/2.$$

The eigenvalue is (4S) 13.69. The other eigenvalues are 9.489 and 6.820.

20. **CAS Experiment.** (a) The midpoint is an approximation for which the endpoints give error bounds.

(b) Nonmonotone behavior may occur if by chance you pick an initial vector close to an eigenvector corresponding to an eigenvalue that is not the greatest in absolute value.

**SECTION 20.8. Power Method for Eigenvalues, page 872**

**Purpose.** Explanation of the power method for determining approximations and error bounds for eigenvalues of real symmetric matrices.

**Main Content, Important Concepts**

- Iteration process of the power method
- Rayleigh quotient (the approximate value)
- Improvement of convergence by a spectral shift
- Scaling (for eigenvectors)

**Short Courses.** Omit spectral shift.

**Comments on Content**

The method is simple but converges slowly, in general.

Symmetry of the matrix is essential to the validity of the error bound (2). The method as such can be applied to more general matrices.

**SOLUTIONS TO PROBLEM SET 20.8, page 875**

2.  $q = 0.8, 0.8, 0.8$ ;  $|\epsilon| \leq 0.6, 0.6, 0.6$ . Eigenvalues  $-1, 1$ .
4.  $q = 6.333, 6.871, 6.976$ ;  $|\epsilon| \leq 2.5, 1.3, 0.49$ . Spectrum  $\{-7, -3, 7\}$ .
6. We obtain the following values:

| Step              | 1      | 2      | 3      | ... | 10     | 20     | 50      | 100     |
|-------------------|--------|--------|--------|-----|--------|--------|---------|---------|
| $q =$             | 8.5    | 8.9938 | 8.9750 | ... | 8.5117 | 6.3511 | -8.8546 | -9.9558 |
| $ \epsilon  \leq$ | 2.9580 | 2.0876 | 2.2048 | ... | 3.6473 | 6.8543 | 4.4640  | 0.1085  |

This illustrates how the iteration begins near an eigenvector not corresponding to an eigenvalue of maximum absolute value but eventually moves away to an eigenvector of the latter. Note also that the bounds become smaller only near the end of the iteration given here. Eigenvalues (4S)  $-9.956, -1.558, 2.283, 9.232$ .

8. The eigenvalues are  $\lambda = \pm 1$ . Corresponding eigenvectors are

$$\mathbf{z}_1 = \begin{bmatrix} 2 \\ 1 \end{bmatrix}, \quad \mathbf{z}_2 = \begin{bmatrix} 1 \\ -2 \end{bmatrix}$$

and we have chosen  $\mathbf{x}_0$  as

$$\mathbf{x}_0 = \begin{bmatrix} 3 \\ -1 \end{bmatrix} = \mathbf{z}_1 + \mathbf{z}_2,$$

so that

$$\begin{aligned} \mathbf{x}_1 &= \mathbf{z}_1 - \mathbf{z}_2 = [1 \quad 3]^\top \\ \mathbf{x}_2 &= \mathbf{z}_1 + \mathbf{z}_2 = [3 \quad -1]^\top \end{aligned}$$

etc. From this,

$$\mathbf{x}_0^\top \mathbf{x}_1 = 0$$

and for the error bound we get

$$\delta = \sqrt{\frac{\mathbf{x}_1^\top \mathbf{x}_1}{\mathbf{x}_0^\top \mathbf{x}_0} - q^2} = \sqrt{\frac{10}{10} - 0} = 1,$$

and similarly in all the further steps. This shows that our error bound is the best possible in general.

10. Let  $\mathbf{z}_1, \dots, \mathbf{z}_n$  be orthonormal eigenvectors corresponding to the eigenvalues  $\lambda_1, \dots, \lambda_n$ , respectively. Then for any initial vector  $\mathbf{x}_0$  we have (summations from 1 to  $n$ )

$$\begin{aligned}\mathbf{x}_0 &= \sum c_j \mathbf{z}_j \\ \mathbf{x}_1 &= \sum c_j \lambda_j \mathbf{z}_j \\ \mathbf{x}_s &= \sum c_j \lambda_j^s \mathbf{z}_j \\ \mathbf{x}_{s+1} &= \sum c_j \lambda_j^{s+1} \mathbf{z}_j\end{aligned}$$

and, using the last step, for the Rayleigh quotient

$$q = \frac{\mathbf{x}_{s+1}^T \mathbf{x}_s}{\mathbf{x}_s^T \mathbf{x}_s} = \frac{\sum c_j^2 \lambda_j^{2s+1}}{\sum c_j^2 \lambda_j^{2s}} \approx \lambda_m$$

where  $\lambda_m$  is of maximum absolute value, and the quality of the approximation increases with increasing number of steps  $s$ . Here we have to assume that  $c_m \neq 0$ , that is, that not just by chance we picked an  $\mathbf{x}_0$  orthogonal to the eigenvector  $\mathbf{z}_m$  of  $\lambda_m$ . The chance that this happens is practically zero, but should it occur, then rounding will bring in a component in the direction of  $\mathbf{z}_m$  and one should eventually expect good approximations, although perhaps only after a great number of steps.

12. **CAS Experiment.** (a) We obtain

16, 41.2, 34.64, 32.888, 32.317, 32.116, 32.043, 32.0158, 32.0059, 32.0022, etc. The spectrum is  $\{32, 12, 8\}$ . Eigenvectors are  $[3 \ 6 \ -7]^T$ ,  $[1 \ 0 \ -1]^T$ ,  $[3 \ -2 \ 1]^T$ .

- (b) For instance, for  $\mathbf{A} - 10\mathbf{I}$  we get

$$q = 6, \ 22.5, \ 22.166, \ 22.007, \ 22.00137,$$

etc. Whereas for  $\mathbf{A}$  the ratio of eigenvalues is  $32/12$ , for  $\mathbf{A} - 10\mathbf{I}$  we have the spectrum  $\{22, 2, -2\}$ , hence the ratio  $22/2$ . This explains the improvement of convergence.

- (d)  $\mathbf{A}$  in (a) provides an example,

|          |    |      |       |        |        |
|----------|----|------|-------|--------|--------|
| $q$      | 16 | 41.2 | 34.64 | 32.888 | 32.317 |
| $\delta$ | 59 | 5.5  | 1.45  | 0.557  | 0.225  |

etc. Also  $\mathbf{A} - 10\mathbf{I}$  does,

|          |    |      |        |        |          |
|----------|----|------|--------|--------|----------|
| $q$      | 6  | 22.5 | 22.166 | 22.007 | 22.00137 |
| $\delta$ | 59 | 3.0  | 0.072  | 0.023  | 0.00055  |

Further examples can easily be found. For instance, the matrix

$$\begin{bmatrix} -2 & 12 \\ 1 & -1 \end{bmatrix}$$

has the spectrum  $\{-5, 2\}$ , but we obtain, with  $\mathbf{x}_0 = [1 \ 1]^T$ ,

|          |   |    |         |         |
|----------|---|----|---------|---------|
| $q$      | 5 | -7 | -4.3208 | -5.2969 |
| $\delta$ | 5 | 2  | 0.37736 | 0.2006  |

etc.

**SECTION 20.9. Tridiagonalization and QR-Factorization, page 875**

**Purpose.** Explanation of an optimal method for determining the whole spectrum of a real symmetric matrix by first reducing the matrix to a tridiagonal matrix with the same spectrum and then applying the QR-method, an iteration in which each step consists of a factorization (5) and a multiplication.

**Comment on Content**

The  $n - 2$  Householder steps ( $n \times n$  the size of the matrix) correspond to similarity transformations; hence the spectrum is preserved. The same holds for QR. But we can perform any number of QR steps, depending on the desired accuracy.

**SOLUTIONS TO PROBLEM SET 20.9, page 882**

2. Householder gives

$$\begin{bmatrix} 0 & -\sqrt{2} & 0 \\ -\sqrt{2} & 1 & 0 \\ 0 & 0 & -1 \end{bmatrix}.$$

Hence  $-1$  is an eigenvalue. The other eigenvalues,  $-1$  and  $2$ , are now obtained by solving the remaining quadratic characteristic equation.

4. By Householder's method we obtain

$$\begin{bmatrix} 8 & -8.48528 & 0 & 0 \\ -8.48528 & 10 & -2.82843 & 0 \\ 0 & -2.82843 & 0 & 0 \\ 0 & 0 & 0 & 2 \end{bmatrix}$$

We see that  $2$  is an eigenvalue. The others are  $0$ ,  $8$ ,  $18$ , unknown in practice, and approximations can be obtained by the QR-method applied to the left upper  $3 \times 3$  principal submatrix.

6. The matrices  $\mathbf{B}$  in the first three steps are

$$\begin{bmatrix} 1.29252 & -0.294200 & 0 \\ -0.294200 & 0.840232 & 0.125969 \\ 0 & 0.125969 & 0.207245 \end{bmatrix}$$

$$\begin{bmatrix} 1.397577 & -0.169658 & 0 \\ -0.169658 & 0.760770 & 0.030349 \\ 0 & 0.030349 & 0.181653 \end{bmatrix}$$

$$\begin{bmatrix} 1.42892 & -0.0886236 & 0 \\ -0.0886236 & 0.730977 & 0.00743888 \\ 0 & 0.00743888 & 0.180102 \end{bmatrix}$$



The eigenvalues are 1.44, 0.72, 0.18 (exactly). The present calculations were done with 10S and then rounded in the result to 6S, and similarly for the other odd- and even-numbered problems because rounding errors tended to accumulate.

8. QR gives the matrices  $\mathbf{B}$  as follows.

$$\begin{bmatrix} 16.2005 & -0.0265747 & 0 \\ -0.0265747 & -4.30089 & 0.190694 \\ 0 & 0.190694 & 4.10043 \end{bmatrix}$$

$$\begin{bmatrix} 16.2005 & -0.00706202 & 0 \\ -0.00706202 & -4.30131 & 0.181822 \\ 0 & 0.181822 & 4.10083 \end{bmatrix}$$

$$\begin{bmatrix} 16.2005 & -0.00187668 & 0 \\ -0.00187668 & -4.30167 & 0.173362 \\ 0 & 0.173362 & 4.10118 \end{bmatrix}$$

6S-values of the eigenvalues are 16.2005,  $-4.30525$ , and 4.10476. Hence the diagonal entries are more accurate than one would expect by looking at the size of the off-diagonal entries.

### SOLUTIONS TO CHAP. 20 REVIEW QUESTIONS AND PROBLEMS, page 883

16.  $[3.9 \ 4.3 \ 1.8]^T$

18.  $[3 \ 3x_3 + 2 \ x_3]^T$ ,  $x_3$  arbitrary, or  $[3 \ t \ \frac{1}{3}(t - 2)]$ ,  $t$  arbitrary

20. All nonzero entries of the triangular matrices are 1.

22. The inverse matrix is

$$\begin{bmatrix} 0 & -4 & 2 \\ 1 & 1 & -1 \\ -2 & 4 & 0 \end{bmatrix}.$$

24. The inverse matrix is (5S)

$$\begin{bmatrix} 0.21239 & -0.035398 & -0.026549 \\ -0.035398 & 0.17257 & 0.0044248 \\ -0.026549 & 0.0044248 & 0.12832 \end{bmatrix}.$$

26. Exact solution 1.6, 0.9, 3.2. The iteration gives the vectors

$$\begin{bmatrix} 1.625 \\ 0.35 \\ 3.20625 \end{bmatrix}, \quad \begin{bmatrix} 1.4625 \\ 0.90156 \\ 3.16562 \end{bmatrix}, \quad \begin{bmatrix} 1.60039 \\ 0.89141 \\ 3.20010 \end{bmatrix}.$$

28. 22,  $\sqrt{194}$ , 11

30. 1, 1, 1

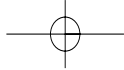

32.  $2.5, \sqrt{2.45}, 1.4$

34. This is the row "sum" norm, equal to 20.

36.  $4.5 \cdot 6 = 27$ , which is rather large

38.  $9 \cdot 0.274336 = 2.46902$

40.  $\sum x_j = 15, \sum x_j^2 = 55, \sum x_j^3 = 225, \sum x_j^4 = 979, \sum y_j = 30, \sum x_j y_j = 86, \sum x_j^2 y_j = 320$ ;  
hence the normal equations are

$$5b_0 + 15b_1 + 55b_2 = 30$$

$$15b_0 + 55b_1 + 225b_2 = 86$$

$$55b_0 + 225b_1 + 979b_2 = 320.$$

Solving by Gauss, we get  $b_0 = 14.2, b_1 = -6.4, b_2 = 1$ . Hence the *answer* is

$$y = 14.2 - 6.4x + x^2.$$

42. By Gerschgorin's theorem, the disks have

center 1.5, radius 3

center 3.5 radius 3.5

center 9.0 radius 2.5.

The eigenvalues are (4D)

$$0.2635, 4.0768, 9.6597.$$

44.  $q_1 = 23/3, |\epsilon_1| \leq 0.95; q_2 = 7.88, |\epsilon_2| \leq 0.82, q_3 = 8.04, |\epsilon_3| \leq 0.70, q_4 = 8.15,$   
 $|\epsilon_4| \leq 0.58$  (2D)

The eigenvalues of the matrix are (5S)

$$8.3429, 6.4707, 4.1864.$$

## CHAPTER 21 Numerics for ODEs and PDEs

### Major Changes

These include automatic variable step size selection in modern codes, the discussion of the Runge–Kutta–Fehlberg method, backward Euler’s method and its application to stiff ODEs, and the extension of Euler and Runge–Kutta methods to systems and higher order equations.

### SECTION 21.1. Methods for First-Order ODEs, page 886

**Purpose.** To explain three numerical methods for solving initial value problems  $y' = f(x, y)$ ,  $y(x_0) = y_0$  by stepwise computing approximations to the solution at  $x_1 = x_0 + h$ ,  $x_2 = x_0 + 2h$ , etc.

#### Main Content, Important Concepts

Euler’s method (3)

Automatic variable step size selection

Improved Euler method (8), Table 21.2

Classical Runge–Kutta method (Table 21.4)

Error and step size control

Runge–Kutta–Fehlberg method

Backward Euler’s method

Stiff ODEs

#### Comments on Content

Euler’s method is good for explaining the principle but is too crude to be of practical value.

The improved Euler method is a simple case of a predictor–corrector method.

The classical Runge–Kutta method is of order  $h^4$  and is of great practical importance.

Principles for a good choice of  $h$  are important in any method.

$f$  in the equation must be such that the problem has a unique solution (see Sec. 1.7).

### SOLUTIONS TO PROBLEM SET 21.1, page 897

2.  $y = e^x$ . Computed values are

| $x_n$ | $y_n$    | $y(x_n)$ | Error    | Error in Prob. 1 |
|-------|----------|----------|----------|------------------|
| 0.01  | 1.010000 | 1.010050 | 0.000050 |                  |
| 0.02  | 1.020100 | 1.020201 | 0.000101 |                  |
| 0.03  | 1.030301 | 1.030455 | 0.000154 |                  |
| 0.04  | 1.040604 | 1.040811 | 0.000207 |                  |
| 0.05  | 1.051010 | 1.051271 | 0.000261 |                  |
| 0.06  | 1.061520 | 1.061837 | 0.000317 |                  |
| 0.07  | 1.072135 | 1.072508 | 0.000373 |                  |
| 0.08  | 1.082857 | 1.083287 | 0.000430 |                  |
| 0.09  | 1.093685 | 1.094174 | 0.000489 |                  |
| 0.10  | 1.104622 | 1.105171 | 0.000549 | 0.005171         |

We see that the error of the last value has decreased by a factor 10, owing to the smaller step.

In most cases the method will be too inaccurate.

4. This is a special Riccati equation. Set  $y + x = u$ , then  $u' = u^2 + 1$  and

$$u'/(u^2 + 1) = 1.$$

By integration,  $\arctan u = x + c$  and

$$u = \tan(x + c) = y + x$$

so that

$$y = \tan(x + c) - x$$

and  $c = 0$  from the initial condition. Hence  $y = \tan x - x$ . The calculation is

| $x_n$ | $y_n$    | $y(x_n)$ | Error    |
|-------|----------|----------|----------|
| 0.1   | 0.000000 | 0.000335 | 0.000335 |
| 0.2   | 0.001000 | 0.002710 | 0.001710 |
| 0.3   | 0.005040 | 0.009336 | 0.004296 |
| 0.4   | 0.014345 | 0.022793 | 0.008448 |
| 0.5   | 0.031513 | 0.046302 | 0.014789 |
| 0.6   | 0.059764 | 0.084137 | 0.024373 |
| 0.7   | 0.103292 | 0.142288 | 0.038996 |
| 0.8   | 0.167820 | 0.289639 | 0.061818 |
| 0.9   | 0.261488 | 0.360158 | 0.098670 |
| 1.0   | 0.396393 | 0.557408 | 0.161014 |

Although the ODE is similar to that in Prob. 3, the error is greater by about a factor 10. This is understandable because  $\tan x$  becomes infinite as  $x \rightarrow \frac{1}{2}\pi$ .

6. The solution is  $y = 1/(1 + 4e^{-x})$ . The 10S-computation, rounded to 6D, gives

| $x_n$ | $y_n$    | $y(x_n)$ | Error $y(x_n) - y_n$ |
|-------|----------|----------|----------------------|
| 0.1   | 0.216467 | 0.216481 | 0.000014             |
| 0.2   | 0.233895 | 0.233922 | 0.000027             |
| 0.3   | 0.252274 | 0.252317 | 0.000043             |
| 0.4   | 0.271587 | 0.271645 | 0.000058             |
| 0.5   | 0.291802 | 0.291875 | 0.000073             |
| 0.6   | 0.312876 | 0.312965 | 0.000089             |
| 0.7   | 0.334754 | 0.334858 | 0.000104             |
| 0.8   | 0.357366 | 0.357485 | 0.000119             |
| 0.9   | 0.380633 | 0.380767 | 0.000134             |
| 1.0   | 0.404462 | 0.404609 | 0.000147             |

8. The solution is  $y = 3 \cos x - 2 \cos^2 x$ . The 10S-computation rounded to 6D gives

| $x_n$ | $y_n$   | $y(x_n)$ | Error $y(x_n) - y_n$ |
|-------|---------|----------|----------------------|
| 0.1   | 1.00492 | 1.00494  | 0.00002              |
| 0.2   | 1.01900 | 1.01914  | 0.00014              |
| 0.3   | 1.04033 | 1.04068  | 0.00035              |
| 0.4   | 1.06583 | 1.06647  | 0.00064              |
| 0.5   | 1.09140 | 1.09245  | 0.00105              |

*(continued)*

| $x_n$ | $y_n$   | $y(x_n)$ | Error $y(x_n) - y_n$ |
|-------|---------|----------|----------------------|
| 0.6   | 1.11209 | 1.11365  | 0.00156              |
| 0.7   | 1.12237 | 1.12456  | 0.00219              |
| 0.8   | 1.11636 | 1.11932  | 0.00296              |
| 0.9   | 1.08817 | 1.09203  | 0.00386              |
| 1.0   | 1.03212 | 1.03706  | 0.00494              |

10. The solution is  $y = 2 \tanh \frac{1}{2}x$ . The 10S-computation rounded to 6D gives

| $x_n$ | $y_n$    | $y(x_n)$ | Error $y(x_n) - y_n$ |
|-------|----------|----------|----------------------|
| 0.1   | 0.099875 | 0.099917 | 0.000042             |
| 0.2   | 0.199252 | 0.199336 | 0.000084             |
| 0.3   | 0.297644 | 0.297770 | 0.000126             |
| 0.4   | 0.394582 | 0.394750 | 0.000168             |
| 0.5   | 0.489626 | 0.489838 | 0.000212             |
| 0.6   | 0.582372 | 0.582626 | 0.000254             |
| 0.7   | 0.672455 | 0.672752 | 0.000297             |
| 0.8   | 0.759561 | 0.759898 | 0.000337             |
| 0.9   | 0.843421 | 0.843798 | 0.000377             |
| 1.0   | 0.923819 | 0.924234 | 0.000415             |

The error is growing relatively slowly, because the solution itself remains less than 2.

12. The solution is  $y = 1/(1 + 4e^{-x})$ . The computation is

| $x_n$ | $y_n$        | Error $y(x_n) - y_n$  |
|-------|--------------|-----------------------|
| 0.1   | 0.2164806848 | $0.043 \cdot 10^{-7}$ |
| 0.2   | 0.2339223328 | $0.085 \cdot 10^{-7}$ |
| 0.3   | 0.2523167036 | $0.128 \cdot 10^{-7}$ |
| 0.4   | 0.2716446148 | $0.170 \cdot 10^{-7}$ |
| 0.5   | 0.2918751118 | $0.209 \cdot 10^{-7}$ |
| 0.6   | 0.3129648704 | $0.249 \cdot 10^{-7}$ |
| 0.7   | 0.3348578890 | $0.284 \cdot 10^{-7}$ |
| 0.8   | 0.3574855192 | $0.318 \cdot 10^{-7}$ |
| 0.9   | 0.3807668746 | $0.346 \cdot 10^{-7}$ |
| 1.0   | 0.4046096381 | $0.370 \cdot 10^{-7}$ |

To apply (10), we need the calculation of five steps with  $h = 0.2$ . We obtain (the third column would not be needed)

| $x_n$ | $y_n$        | Error $y(x_n) - y_n$  |
|-------|--------------|-----------------------|
| 0.2   | 0.2339222103 | $1.310 \cdot 10^{-7}$ |
| 0.4   | 0.2716443697 | $2.621 \cdot 10^{-7}$ |
| 0.6   | 0.3129645099 | $3.854 \cdot 10^{-7}$ |
| 0.8   | 0.3574850569 | $4.941 \cdot 10^{-7}$ |
| 1.0   | 0.4046090919 | $5.832 \cdot 10^{-7}$ |

Hence the required error estimate is

$$(0.4046096381 - 0.4046090919)/15 = 0.364 \cdot 10^{-7}.$$

The actual error is  $0.370 \cdot 10^{-7}$ ; the estimate is closer than one can expect in general.

14. The solution is  $y = \sqrt{4x - x^2}$ ; thus  $(x - 2)^2 + y^2 = 4$  (see Example 6 in Sec. 1.3 with  $c = 4$ ). The computation with RK gives

| $x_n$ | $y_n$        | Error $y(x_n) - y_n$   |
|-------|--------------|------------------------|
| 2.0   | 2.000000000  | 0                      |
| 2.2   | 1.989975031  | $-0.157 \cdot 10^{-6}$ |
| 2.4   | 1.959592041  | $-0.247 \cdot 10^{-6}$ |
| 2.6   | 1.907878667  | $-0.264 \cdot 10^{-6}$ |
| 2.8   | 1.833030447  | $-0.169 \cdot 10^{-6}$ |
| 3.0   | 1.732050655  | $+0.153 \cdot 10^{-6}$ |
| 3.2   | 1.599998963  | $0.1037 \cdot 10^{-5}$ |
| 3.4   | 1.428281966  | $0.3720 \cdot 10^{-5}$ |
| 3.6   | 1.199985280  | 0.000014720            |
| 3.8   | 0.8716743295 | $+0.0001054592$        |
| 4.0   | 0.0977998883 | $-0.0977998883$        |

A graph shows that these values lie on the corresponding quarter-circle within the accuracy of graphing and that they are irregularly spaced as the  $x$ -values suggest.

16. The solution is  $y = 3 \cos x - 2 \cos^2 x$ . The computation gives

| $x_n$ | $y_n$       | Error $y(x_n) - y_n$     | Error in Prob. 15      |
|-------|-------------|--------------------------|------------------------|
| 0.2   | 1.019137566 | $0.1173 \cdot 10^{-5}$   | $0.74 \cdot 10^{-7}$   |
| 0.4   | 1.066471079 | $0.5194 \cdot 10^{-5}$   | $0.328 \cdot 10^{-6}$  |
| 0.6   | 1.113634713 | $0.14378 \cdot 10^{-4}$  | $0.904 \cdot 10^{-6}$  |
| 0.8   | 1.119282901 | $0.36749 \cdot 10^{-4}$  | $0.2277 \cdot 10^{-5}$ |
| 1.0   | 1.036951866 | $0.101888 \cdot 10^{-3}$ | $0.6142 \cdot 10^{-5}$ |

Note that the ratio of the errors is about the same for all  $x_n$ , about  $2^4$ .

18. From  $y' = x + y$  and the given formula we get, with  $h = 0.2$ ,

$$k_1 = 0.2(x_n + y_n)$$

$$\begin{aligned} k_2 &= 0.2[x_n + 0.1 + y_n + 0.1(x_n + y_n)] \\ &= 0.2[1.1(x_n + y_n) + 0.1] \end{aligned}$$

$$\begin{aligned} k_3^* &= 0.2[x_n + 0.2 + y_n - 0.2(x_n + y_n) + 0.4[1.1(x_n + y_n) + 0.1]] \\ &= 0.2[1.24(x_n + y_n) + 0.24] \end{aligned}$$

and from this

$$y_{n+1} = y_n + \frac{1}{6}[1.328(x_n + y_n) + 0.128].$$

The computed values are

| $x_n$ | $y_n$     | Error     |
|-------|-----------|-----------|
| 0.0   | 0.000 000 | 0.000 000 |
| 0.2   | 0.021 333 | 0.000 067 |
| 0.4   | 0.091 655 | 0.000 165 |
| 0.6   | 0.221 808 | 0.000 312 |
| 0.8   | 0.425 035 | 0.000 505 |
| 1.0   | 0.717 509 | 0.000 771 |

**20. CAS Experiment.** (b) The computation is

| $x_n$ | $y_n$        | Error Estimate $(10) \cdot 10^9$ | Error $\cdot 10^9$ |
|-------|--------------|----------------------------------|--------------------|
| 0.1   | 1.2003346725 | 3.0                              | -0.4               |
| 0.2   | 1.4027100374 | 3.7                              | -1.9               |
| 0.3   | 1.6093362546 | 5.9                              | -5.0               |
| 0.4   | 1.8227932298 | 9.4                              | -11.0              |
| 0.5   | 2.0463025124 | 13.1                             | -22.5              |
| 0.6   | 2.2841368531 | 14.4                             | -44.7              |
| 0.7   | 2.5422884689 | +5.0                             | -88.4              |
| 0.8   | 2.8296387346 | -38.8                            | -177.6             |
| 0.9   | 3.1601585865 | -191.1                           | -369.0             |
| 1.0   | 3.5574085377 | -699.9                           | -813.0             |

**SECTION 21.2. Multistep Methods, page 898**

**Purpose.** To explain the idea of a multistep method in terms of the practically important Adams–Moulton method, a predictor–corrector method that in each computation uses four preceding values.

**Main Content, Important Concepts**

Adams–Bashforth method (5)

Adams–Moulton method (7)

Self-starting and not self-starting

Numerical stability, fair comparison

**Short Courses.** This section may be omitted.

**SOLUTIONS TO PROBLEM SET 21.2, page 901**

2. The computation with the use of the given starting values is as follows. The exact solution is  $y = e^x$ .

| $n$ | $x_n$ | Starting<br>$y_n$ | Predicted<br>$y_n^*$ | Corrected<br>$y_n$ | Exact     |
|-----|-------|-------------------|----------------------|--------------------|-----------|
| 0   | 0.0   | 1.000 000         |                      |                    |           |
| 1   | 0.1   | 1.105 171         |                      |                    |           |
| 2   | 0.2   | 1.221 403         |                      |                    |           |
| 3   | 0.3   | 1.349 859         |                      |                    |           |
| 4   | 0.4   |                   | 1.491 821            | 1.491 825          | 1.491 825 |
| 5   | 0.5   |                   | 1.648 717            | 1.648 722          | 1.648 721 |
| 6   | 0.6   |                   | 1.822 114            | 1.822 120          | 1.822 119 |
| 7   | 0.7   |                   | 2.013 748            | 2.013 754          | 2.013 753 |
| 8   | 0.8   |                   | 2.225 536            | 2.225 543          | 2.225 541 |
| 9   | 0.9   |                   | 2.459 598            | 2.459 605          | 2.459 603 |
| 10  | 1.0   |                   | 2.718 277            | 2.718 285          | 2.718 282 |

4. The solution is  $y = e^{x^2}$ . The computation gives

| $x_n$ | $y_n$    | Error $\cdot 10^6$ |
|-------|----------|--------------------|
| 0.4   | 1.173518 | -7                 |
| 0.5   | 1.284044 | -19                |
| 0.6   | 1.433364 | -35                |
| 0.7   | 1.632374 | -59                |
| 0.8   | 1.896572 | -92                |
| 0.9   | 2.248046 | -139               |
| 1.0   | 2.718486 | -205               |

6. The comparison shows that in the present case, RK is better. The comparison is fair since we have four evaluations per step for RK, but only two for AM. The errors are:

| $x$ | 0.4                  | 0.6                  | 0.8                  | 1.0                   |
|-----|----------------------|----------------------|----------------------|-----------------------|
| AM  | $-0.7 \cdot 10^{-5}$ | $-3.5 \cdot 10^{-5}$ | $-9.2 \cdot 10^{-5}$ | $-20.5 \cdot 10^{-5}$ |
| RK  | $0.1 \cdot 10^{-5}$  | $0.8 \cdot 10^{-5}$  | $4.0 \cdot 10^{-5}$  | $17.5 \cdot 10^{-5}$  |

8. The solution is  $y^2 - x^2 = 8$ . Computation gives:

| $x_n$ | $y_n$   | Error $\cdot 10^6$ |
|-------|---------|--------------------|
| 1.2   | 3.07246 | -0.02              |
| 1.4   | 3.15595 | -0.04              |
| 1.6   | 3.24962 | -0.06              |
| 1.8   | 3.35261 | -0.8               |
| 2.0   | 3.46410 | -1.3               |
| 2.2   | 3.58330 | -1.6               |
| 2.4   | 3.70945 | -1.7               |
| 2.6   | 3.84188 | -1.7               |
| 2.8   | 3.97995 | -1.6               |
| 3.0   | 4.12311 | -1.5               |

10. The solution is  $y = \frac{1}{2} \tanh 2x$ . Computation gives:

| $x_n$ | $y_n$    | Exact    | Error $\cdot 10^6$ |
|-------|----------|----------|--------------------|
| 0.1   | 0.98686  | 0.098688 | 1                  |
| 0.2   | 0.189971 | 0.189974 | 3                  |
| 0.3   | 0.268519 | 0.268525 | 6                  |
| 0.4   | 0.332007 | 0.332018 | 11                 |
| 0.5   | 0.380726 | 0.380797 | 71                 |
| 0.6   | 0.416701 | 0.416828 | 127                |
| 0.7   | 0.442532 | 0.442676 | 144                |
| 0.8   | 0.460706 | 0.460834 | 128                |
| 0.9   | 0.473306 | 0.473403 | 97                 |
| 1.0   | 0.481949 | 0.482014 | 65                 |



14.  $y = e^{x^2}$ . Some of the values and errors are:

| $x_n$ | $y_n (h = 0.05)$ | Error $\cdot 10^6$ | $y_n (h = 0.1)$ | Error $\cdot 10^6$ |
|-------|------------------|--------------------|-----------------|--------------------|
| 0.1   | 1.010050         |                    | 1.01005         |                    |
| 0.2   | 1.040817         | -6                 | 1.040811        |                    |
| 0.3   | 1.094188         | -14                | 1.094224        | -50                |
| 0.4   | 1.173535         | -24                | 1.173623        | -112               |
| 0.5   | 1.284064         | -38                | 1.284219        | -194               |
| 0.6   | 1.433388         | -58                | 1.433636        | -307               |
| 0.7   | 1.632404         | -87                | 1.632782        | -466               |
| 0.8   | 1.896612         | -131               | 1.897175        | -694               |
| 0.9   | 2.248105         | -197               | 2.248931        | -1023              |
| 1.0   | 2.718579         | -297               | 2.719785        | -1503              |

The errors differ by a factor 4 to 5, approximately.

### SECTION 21.3. Methods for Systems and Higher Order ODEs, page 902

**Purpose.** Extension of the methods in Sec. 21.1 to first-order systems and to higher order ODEs.

#### Content

Euler's method for systems (5)

Classical Runge-Kutta method extended to systems (6)

Runge-Kutta-Nyström method (7)

**Short Courses.** Discuss merely Runge-Kutta (6), which shows that this "vectorial extension" of the method is conceptually quite simple.

### SOLUTIONS TO PROBLEM SET 21.3, page 908

2. The solution is  $y_1 = e^{-2x} + e^{-4x}$ ,  $y_2 = e^{-2x} - e^{-4x}$ . The computation is

| $x_n$ | $y_{1,n}$ | Error  | $y_{2,n}$ | Error   |
|-------|-----------|--------|-----------|---------|
| 0.1   | 1.4       | 0.0890 | 0.2       | -0.0516 |
| 0.2   | 1.00      | 0.1196 | 0.28      | -0.0590 |
| 0.3   | 0.728     | 0.1220 | 0.296     | -0.0484 |
| 0.4   | 0.5392    | 0.1120 | 0.2800    | -0.0326 |
| 0.5   | 0.4054    | 0.0978 | 0.2499    | -0.0174 |

The figure shows (for  $x = 0, \dots, 1$ ) that these values give a qualitatively correct impression, although they are rather inaccurate. Note that the error of  $y_1$  is not monotone.

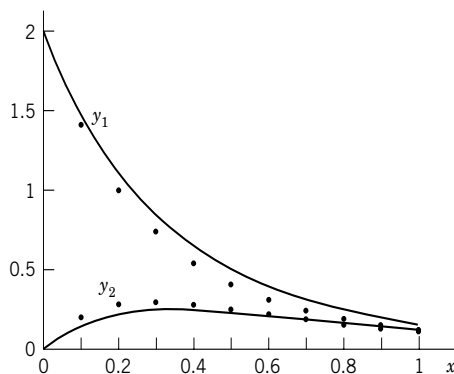

**Section 21.3.** Solution curves and computed values in Problem 2

4. Solution  $y_1 = 2e^x$ ,  $y_2 = 2e^{-x}$  (see also Example 3 in Sec. 4.3). The computation is

| $x_n$ | $y_{1,n}$ | Error  | $y_{2,n}$ | Error   |
|-------|-----------|--------|-----------|---------|
| 0.1   | 2.2       | 0.0104 | 1.8       | 0.0097  |
| 0.2   | 2.42      | 0.0228 | 1.62      | 0.0175  |
| 0.3   | 2.662     | 0.0378 | 1.458     | 0.0236  |
| 0.4   | 2.9282    | 0.0554 | 1.3122    | 0.0284  |
| 0.5   | 3.2210    | 0.0764 | 1.1810    | 0.0321  |
| 0.6   | 3.5431    | 0.1011 | 1.0629    | 0.0347  |
| 0.7   | 3.8974    | 0.1302 | 0.95659   | 0.03659 |
| 0.8   | 4.2872    | 0.1638 | 0.86093   | 0.03773 |
| 0.9   | 4.7159    | 0.2033 | 0.77484   | 0.03830 |
| 1.0   | 5.1875    | 0.2491 | 0.69736   | 0.03840 |

The figure illustrates that the error of  $y_1$  is monotone increasing and is positive (the points lie below that curve), and similarly for  $y_2$ .

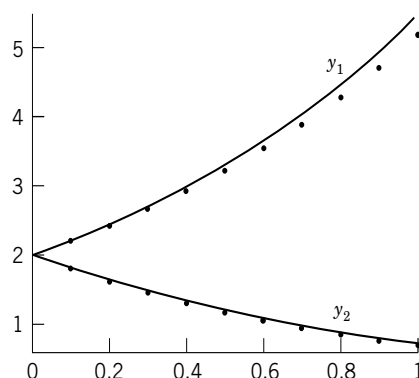

**Section 21.3.** Solution curves and computed values (the dots) in Problem 4

6. The system is  $y_1' = y_2$ ,  $y_2' = y_1 + x$ ,  $y_1(0) = 1$ ,  $y_2(0) = -2$ . The exact solution is  $y = y_1 = e^{-x} - x$ ; hence  $y' = y_2 = -e^{-x} - 1$ . The computation is

| $x_n$ | $y_{1,n}$ | Error  | $y_{2,n}$ | Error   |
|-------|-----------|--------|-----------|---------|
| 0.1   | 0.8       | 0.0048 | -1.9      | -0.0048 |
| 0.2   | 0.61      | 0.0087 | -1.81     | -0.0087 |
| 0.3   | 0.429     | 0.0118 | -1.729    | -0.0118 |
| 0.4   | 0.2561    | 0.0142 | -1.6561   | -0.0142 |
| 0.5   | 0.0905    | 0.0160 | -1.5905   | -0.0160 |

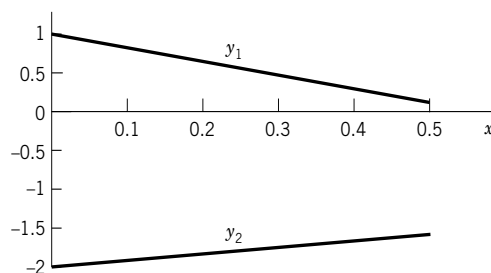

**Section 21.3.** Solution curves in Problem 6. Computed values lie practically on the curves.

10. The error has decreased by about a factor  $10^5$ . The computation is:

| $x_n$ | $y_{1,n}$   | Error $\cdot 10^6$ | $y_{2,n}$   | Error $\cdot 10^6$ |
|-------|-------------|--------------------|-------------|--------------------|
| 0.1   | 0.804837500 | -0.082             | -1.90483750 | 0.08               |
| 0.2   | 0.618730902 | -0.15              | -1.81873090 | 0.15               |
| 0.3   | 0.440818422 | -0.20              | -1.74081842 | 0.20               |
| 0.4   | 0.270320289 | -0.24              | -1.67032029 | 0.24               |
| 0.5   | 0.106530935 | -0.27              | -1.60653093 | 0.27               |

12. Division by  $x$  gives  $y'' + y'/x + y = 0$ . The system is  $y_1' = y_2$ ,  $y_2' = y'' = -y_2/x - y_1$ . Because of the factor  $1/x$  we have to choose  $x_0 \neq 0$ . The computation gives, with the initial values taken from Ref. [GR1] in App. 1:

| $x_n$ | $J_0(x_n)$ | $J_0'(x_n)$ | $10^6 \cdot \text{Error of } J_0(x_n)$ |
|-------|------------|-------------|--|
| 1     | 0.765198   | -0.440051   | 0                                      |
| 1.5   | 0.511903   | -0.558002   | -76                                    |
| 2     | 0.224008   | -0.576897   | -117                                   |
| 2.5   | -0.048289  | -0.497386   | -95                                    |
| 3     | -0.260055  | -0.339446   | +3                                     |
| 3.5   | -0.380298  | -0.137795   | 170                                    |

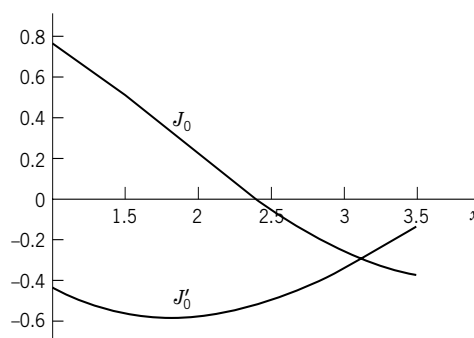

**Section 21.3.** Solution curves in Problem 12. Computed values lie practically on the curves.

14. The error is reduced very substantially, by about a factor 1000. The computation is:

| $x_n$ | $y_{1,n}$ | Error $\cdot 10^4$ | $y_{2,n}$ | Error $\cdot 10^4$ |
|-------|-----------|--------------------|-----------|--------------------|
| 0.1   | 1.489133  | -0.82              | 0.148333  | 0.78               |
| 0.2   | 1.119760  | -1.11              | 0.220888  | 1.03               |
| 0.3   | 0.850119  | -1.13              | 0.247515  | 1.03               |
| 0.4   | 0.651327  | -1.02              | 0.247342  | 0.90               |
| 0.5   | 0.503301  | -0.87              | 0.232469  | 0.75               |

16.

| $x_n$ | $y_n$      | $k_1$      | $k_2$      | $k_3$      | $k_4$      | $10^6 \cdot$ Error<br>of $y_n$ |
|-------|------------|------------|------------|------------|------------|--------------------------------|
| 1.0   | 0.765 198  | -0.081 287 | -0.056 989 | -0.061 848 | -0.034 604 | 0                              |
| 1.5   | 0.511 819  | -0.034 970 | -0.007 296 | -0.011 250 | +0.015 740 | +9                             |
| 2.0   | +0.223 946 | +0.016 098 | +0.041 840 | +0.038 979 | 0.061 098  | -55                            |
| 2.5   | -0.048 241 | 0.061 767  | 0.080 770  | 0.079 042  | 0.092 562  | -143                           |
| 3.0   | -0.259 845 | 0.093 218  | 0.102 154  | 0.101 466  | 0.104 389  | -207                           |
| 3.5   | -0.379 914 |            |            |            |            | -214                           |

In the present case the errors of the two methods are of the same order of magnitude. An exact comparison is not possible, since the errors change sign in a different fashion in each method.

18. This gives the second solution ( $y = x \ln x + 1$ ) in Example 3 of Sec. 5.4, which has a logarithmic term. (The first solution is  $y = x$ .) For RKN we write the ODE as

$$y'' = (x^2 - x)^{-1}(xy' - y).$$

We choose  $x_0 = 1/2$ , between the critical points 0 and 1, and restrict the computation to four steps, to avoid reaching  $x = 1$ . The computation is:

| $x_n$ | $y_n$    | $y'_n$   | $10^5 \cdot$ Error of $y_n$ |
|-------|----------|----------|-----------------------------|
| 0.5   | 0.653426 | 0.306853 | 0                           |
| 0.6   | 0.693512 | 0.489173 | -0.8                        |
| 0.7   | 0.750337 | 0.643313 | -0.9                        |
| 0.8   | 0.821492 | 0.776823 | -0.7                        |
| 0.9   | 0.905188 | 0.894503 | -1.3                        |

20. **CAS Experiment.** (b) A general answer seems difficult to give, since the form of the coefficients, their variability, and other general properties are essential.  
(c) Elimination of the first derivative tends to complicate the ODE, so that one may lose more than gain in using the simpler algorithm.

## SECTION 21.4. Methods for Elliptic PDEs, page 909

**Purpose.** To explain numerical methods for the Dirichlet problem involving the Laplace equation, the typical representative of elliptic PDEs.

### Main Content, Important Concepts

Elliptic, parabolic, hyperbolic equations

Dirichlet, Neumann, mixed problems

Difference analogs (7), (8) of Poisson's and Laplace's equations

Coefficient scheme (9)

Liebmann's method of solution (identical with Gauss–Seidel, Sec. 20.3)

Peaceman–Rachford's ADI method (15)

**Short Courses.** Omit the ADI method.

**Comments on Content**

Neumann's problem and the mixed problem follow in the next section, including the modification in the case of irregular boundaries.

The distinction between the three kinds of PDEs (elliptic, parabolic, hyperbolic) is not merely a formal matter because the solutions of the three types behave differently in principle, and the boundary and initial conditions are different; this necessitates different numerical methods, as we shall see.

**SOLUTIONS TO PROBLEM SET 21.4, page 916**

2. Gauss gives the values of the exact solution  $u(x, y) = x^3 - 3xy^2$ . Gauss–Seidel needs about 10 steps for producing 5S-values:

| $n$ | $u_{11}$ | $u_{21}$ | $u_{12}$ | $u_{22}$ |
|-----|----------|----------|----------|----------|
| 1   | 50.25    | 44.062   | 31.062   | 5.031    |
| 2   | 19.031   | 12.516   | -0.4845  | -10.742  |
| 3   | 3.2579   | 4.6290   | -8.3710  | -14.686  |
| 4   | -0.6855  | 2.6571   | -10.343  | -15.672  |
| 5   | -1.6715  | 2.1641   | -10.836  | -15.918  |
| 6   | -1.9180  | 2.0410   | -10.959  | -15.980  |
| 7   | -1.9795  | 2.0101   | -10.990  | -15.995  |
| 8   | -1.9950  | 2.0025   | -10.998  | -15.999  |
| 9   | -1.9989  | 2.0005   | -11.000  | -16.000  |
| 10  | -1.9999  | 2.0000   | -11.000  | -16.000  |

It is interesting that it takes only 4 or 5 steps to turn the values away from the starting values to values that are already relatively close to the respective limits.

4. The values of the exact solution of the Laplace equation are

$$u(1, 1) = -4, \quad u(2, 1) = u(1, 2) = -7, \quad u(2, 2) = -64.$$

Gauss gives  $-2, -5, -5, -62$ . Corresponding errors are  $-2, -2, -2, -2$ . Gauss–Seidel needs about 10 steps for producing 5S-values:

| $n$ | $u_{11}$ | $u_{21}$ | $u_{12}$ | $u_{22}$ |
|-----|----------|----------|----------|----------|
| 1   | 50.50    | 48.625   | 48.625   | -35.188  |
| 2   | 24.812   | 8.4060   | 8.4060   | -55.297  |
| 3   | 4.7030   | -1.648   | -1.648   | -60.324  |
| 4   | -0.32400 | -4.162   | -4.162   | -61.581  |
| 5   | -1.5810  | -4.790   | -4.790   | -61.895  |
| 6   | -1.8950  | -4.948   | -4.948   | -61.974  |
| 7   | -1.9740  | -4.987   | -4.987   | -61.994  |
| 8   | -1.9935  | -4.997   | -4.997   | -61.998  |
| 9   | -1.9985  | -4.999   | -4.999   | -62.000  |
| 10  | -1.9995  | -5.000   | -5.000   | -62.000  |

6. 165, 165, 165, 165 by Gauss. The Gauss–Seidel computation gives

| $n$ | $u_{11}$ | $u_{21}$ | $u_{12}$ | $u_{22}$ |
|-----|----------|----------|----------|----------|
| 1   | 132.50   | 140.62   | 140.62   | 152.81   |
| 2   | 152.81   | 158.90   | 158.90   | 161.95   |
| 3   | 161.95   | 163.48   | 163.48   | 164.24   |
| 4   | 164.24   | 164.62   | 164.62   | 164.81   |
| 5   | 164.81   | 164.90   | 164.90   | 164.95   |
| 6   | 164.95   | 164.98   | 164.98   | 164.99   |
| 7   | 164.99   | 165.00   | 165.00   | 165.00   |
| 8   | 165.00   | 165.00   | 165.00   | 165.00   |

8. 6 steps. Some results are

$$[93.75 \quad 90.625 \quad 65.625 \quad 64.0625] \quad (\text{Step 2})$$

$$[87.8906 \quad 87.6953 \quad 62.6953 \quad 62.5976] \quad (\text{Step 4})$$

$$[87.5244 \quad 87.5122 \quad 62.5122 \quad 62.5061] \quad (\text{Step 6})$$

$$[87.5001 \quad 87.5000 \quad 62.5000 \quad 62.5000] \quad (\text{Step 10})$$

10.  $u_{11} = 92.86$ ,  $u_{21} = 90.18$ ,  $u_{12} = 81.25$ ,  $u_{22} = 75.00$ ,  $u_{13} = 57.14$ ,  
 $u_{23} = 47.32$ ,  $u_{31} = u_{11}$ , etc., by symmetry.

12. All the isotherms must begin and end at a corner. The diagonals are isotherms  $u = 25$ , because of the data obtained and for reasons of symmetry. Hence we obtain a qualitative picture as the figure shows.

In Prob. 7 the situation is similar.

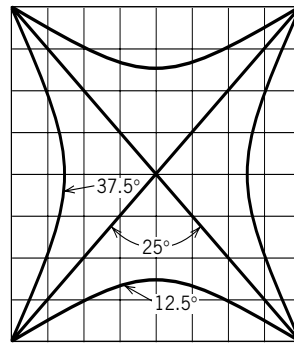

Section 21.4. Problem 12

14. This shows the importance of good starting values; it then does not take long until the approximations come close to the solution. A rule of thumb is to take a rough estimate of the average of the boundary values at the points that enter the linear system. By starting from  $\mathbf{0}$  we obtain

$$[0.09472 \quad 0.10148 \quad 0.31798 \quad 0.32136] \quad (\text{Step 3})$$

$$[0.10740 \quad 0.10782 \quad 0.32432 \quad 0.32454] \quad (\text{Step 5}).$$

16. *Step 1.* First come rows  $j = 1, j = 2$ ; for these, (14a) is

$$\begin{aligned}
 j = 1, \quad i = 1. \quad & u_{01} - 4u_{11} + u_{21} = -u_{10} - u_{12} \\
 & i = 2. \quad u_{11} - 4u_{21} + u_{31} = -u_{20} - u_{22} \\
 j = 2, \quad i = 1. \quad & u_{02} - 4u_{12} + u_{22} = -u_{11} - u_{13} \\
 & i = 2. \quad u_{12} - 4u_{22} + u_{32} = -u_{21} - u_{23}.
 \end{aligned}$$

Six of the boundary values are zero, and the two on the upper edge are

$$u_{13} = u_{23} = \sqrt{3}/2 = 0.866\,025.$$

Also, on the right we substitute the starting values 0. With this, our four equations become

$$\begin{aligned}
 -4u_{11} + u_{21} &= 0 \\
 u_{11} - 4u_{21} &= 0 \\
 -4u_{12} + u_{22} &= -0.866\,025 \\
 u_{12} - 4u_{22} &= -0.866\,025.
 \end{aligned}$$

From the first two equations,

$$u_{11} = 0, \quad u_{21} = 0$$

and from the other two equations,

$$u_{12} = 0.288\,675, \quad u_{22} = 0.288\,675.$$

**Step 1.** Now come *columns*; for these, (14b) is

$$\begin{aligned}
 i = 1, \quad j = 1. \quad & u_{10} - 4u_{11} + u_{12} = -u_{01} - u_{21} \\
 & j = 2. \quad u_{11} - 4u_{12} + u_{13} = -u_{02} - u_{22} \\
 i = 2, \quad j = 1. \quad & u_{20} - 4u_{21} + u_{22} = -u_{11} - u_{31} \\
 & j = 2. \quad u_{21} - 4u_{22} + u_{23} = -u_{12} - u_{32}.
 \end{aligned}$$

With the boundary values and the previous solution *on the right*, this becomes

$$\begin{aligned}
 -4u_{11} + u_{12} &= 0 \\
 u_{11} - 4u_{12} &= -0.866\,025 - 0.288\,675 \\
 -4u_{21} + u_{22} &= 0 \\
 u_{21} - 4u_{22} &= -0.866\,025 - 0.288\,675.
 \end{aligned}$$

The solution is

$$\begin{aligned}
 u_{11} &= 0.076\,98 \\
 u_{21} &= 0.076\,98 \\
 u_{12} &= 0.307\,92 \\
 u_{22} &= 0.307\,92.
 \end{aligned}$$

**Step 2. Rows.** We can use the previous equations, changing only the right sides:

$$\begin{aligned}
 -4u_{11} + u_{21} &= -0.307\,92 \\
 u_{11} - 4u_{21} &= -0.307\,92 \\
 -4u_{12} + u_{22} &= -0.866\,025 - 0.076\,98 \\
 u_{12} - 4u_{22} &= -0.866\,025 - 0.076\,98
 \end{aligned}$$

*Solution:*

$$u_{11} = u_{21} = 0.102\ 640, \quad u_{12} = u_{22} = 0.314\ 335.$$

**Step 2. Columns.** The equations with the new right sides are

$$-4u_{11} + u_{12} = -0.102\ 640$$

$$u_{11} - 4u_{12} = -0.866\ 025 - 0.314\ 335$$

$$-4u_{21} + u_{22} = -0.102\ 640$$

$$u_{21} - 4u_{22} = -0.866\ 025 - 0.314\ 335.$$

Final result (solution of these equations):

$$u_{11} = 0.106\ 061$$

$$u_{21} = 0.106\ 061$$

$$u_{12} = 0.321\ 605$$

$$u_{22} = 0.321\ 605.$$

Exact 3D values:

$$u_{11} = u_{21} = 0.108, \quad u_{12} = u_{22} = 0.325.$$

**18. CAS Project.** (b) The solution of the linear system (rounded to integers), with the values arranged as the points in the  $xy$ -plane, is

|     |     |     |     |
|-----|-----|-----|-----|
| 160 | 170 | 157 | 110 |
| 138 | 145 | 125 | 75  |
| 138 | 145 | 125 | 75  |
| 160 | 170 | 157 | 110 |

Twenty steps gave accuracies of 3S–5S, with slight variations between the components of the output vector.

### SECTION 21.5. Neumann and Mixed Problems. Irregular Boundary, page 917

**Purpose.** Continuing our discussion of elliptic PDEs, we explain the ideas needed for handling Neumann and mixed problems and the modifications required when the domain is no longer a rectangle.

#### Main Content, Important Concepts

Mixed problem for a Poisson equation (Example 1)

Modified stencil (6) (notation in Fig. 459)

#### Comments on Content

Neumann's problem can be handled as explained in Example 1 on the mixed problem.

In all the cases of an elliptic PDE we need only *one* boundary condition at each point (given  $u$  or given  $u_n$ ).

### SOLUTIONS TO PROBLEM SET 21.5, page 921

6.  $0 = u_{01,x} = \frac{1}{2h}(u_{11} - u_{-1,1})$  gives  $u_{-1,1} = u_{11}$ . Similarly,  $u_{41} = u_{21} + 3$  from the condition on the right edge, so that the equations are



$$\begin{aligned}
 -4u_{01} + 2u_{11} &= 1 \\
 u_{01} - 4u_{11} + u_{21} &= -0.25 + 0.75 = 0.5 \\
 u_{11} - 4u_{21} + u_{31} &= -1 \\
 2u_{21} - 4u_{31} &= -2.25 - 1.25 - 3 = -6.5.
 \end{aligned}$$

$u_{01} = -0.25$ ,  $u_{11} = 0$ ,  $u_{21} = 0.75$ ,  $u_{31} = 2$ ; this agrees with the values of the exact solution  $u(x, y) = x^2 - y^2$  of the problem.

8. The exact solution of the Poisson equation is  $u = x^2y^2$ . The approximate solution results from  $\mathbf{A}\mathbf{u} = \mathbf{b}$ , where

$$\mathbf{A} = \begin{bmatrix} -4 & 1 & 0 & 1 & 0 & 0 \\ 1 & -4 & 1 & 0 & 1 & 0 \\ 0 & 2 & -4 & 0 & 0 & 1 \\ 1 & 0 & 0 & -4 & 1 & 0 \\ 0 & 1 & 0 & 1 & -4 & 1 \\ 0 & 0 & 1 & 0 & 2 & -4 \end{bmatrix}, \quad \mathbf{b} = \begin{bmatrix} 4 \\ 10 \\ 8 \\ 1 \\ -20 \\ -103 \end{bmatrix}$$

where the six equations correspond to  $P_{11}$ ,  $P_{21}$ ,  $P_{31}$ ,  $P_{12}$ ,  $P_{22}$ ,  $P_{32}$ , in our usual order. The components of  $\mathbf{b}$  are of the form  $a - c$  with  $a$  resulting from  $2(x^2 + y^2)$  and  $c$  from the boundary values; thus,  $4 - 0 = 4$ ,  $10 - 0 = 10$ ,  $20 - 12 = 8$ ,  $10 - 9 = 1$ ,  $16 - 36 = -20$ ,  $26 - 81 - 48 = -103$ . The solution of this system agrees with the values obtained at the  $P_{jk}$  from the exact solution,  $u_{11} = 1$ ,  $u_{21} = u_{12} = 4$ ,  $u_{22} = 16$ , and  $u_{31} = 9$ ,  $u_{32} = 36$  on the boundary.  $u_{41} = u_{21} + 12$  and  $u_{42} = u_{22} + 48$  produced entries 2 in  $\mathbf{A}$  and  $-12$  and  $-48$  in  $\mathbf{b}$ .

10. Exact solution  $u = 9y \sin \frac{1}{3}\pi x$ . Linear system  $\mathbf{A}\mathbf{u} = \mathbf{b}$ , where

$$\mathbf{A} = \begin{bmatrix} -4 & 1 & 1 & 0 & 0 & 0 \\ 1 & -4 & 0 & 1 & 0 & 0 \\ 1 & 0 & -4 & 1 & 1 & 0 \\ 0 & 1 & 1 & -4 & 0 & 1 \\ 0 & 0 & 2 & 0 & -4 & 1 \\ 0 & 0 & 0 & 2 & 1 & -4 \end{bmatrix}, \quad \mathbf{b} = \begin{bmatrix} a \\ a \\ 2a \\ 2a \\ 3a + c \\ 3a + c \end{bmatrix}$$

$a = -8.54733$ ,  $c = -\sqrt{243} = -15.5885$ . The solution of this system is (exact values of  $u$  in parentheses)

$$\begin{aligned}
 u_{11} = u_{21} &= 8.46365 \quad (\text{exact } \frac{9}{2}\sqrt{3} = 7.79423) \\
 u_{12} = u_{22} &= 16.8436 \quad (\text{exact } 9\sqrt{3} = 15.5885) \\
 u_{13} = u_{23} &= 24.9726 \quad (\text{exact } \frac{27}{2}\sqrt{3} = 23.3827).
 \end{aligned}$$

12. Let  $v$  denote the unknown boundary potential. Then  $v$  occurs in  $\mathbf{A}\mathbf{u} = \mathbf{b}$ , where

$$\mathbf{A} = \begin{bmatrix} -4 & 1 & 1 & 0 \\ 1 & -4 & 0 & 1 \\ 1 & 0 & -4 & 1 \\ 0 & \frac{2}{3} & \frac{2}{3} & -4 \end{bmatrix}, \quad \mathbf{b} = \begin{bmatrix} 0 \\ -v \\ -v \\ -\frac{8}{3}v \end{bmatrix}.$$

The solution of this linear system is  $\mathbf{u} = \frac{v}{19} [5 \ 10 \ 10 \ 16]^T$ . From this and  $5v/19 = 100$  (the potential at  $P_{11}$ ) we have  $v = 380$  V as the constant boundary potential on the indicated portion of the boundary.

14. Two equations are as usual:

$$\begin{aligned} -4u_{11} + u_{21} + u_{12} - 2 &= 2 \\ u_{11} - 4u_{21} - 0.5 &= 2 \end{aligned}$$

where the right side is due to the fact that we are dealing with the Poisson equation. The third equation results from (6) with  $a = p = q = 1$  and  $b = 1/2$ . We get

$$2 \left[ \frac{u_{22}}{2} + \frac{u_{1.5/2}}{3/4} + \frac{u_{02}}{2} + \frac{u_{11}}{3/2} - \frac{3/2}{1/2} u_{12} \right] = 2.$$

The first two terms are zero and  $u_{02} = -2$ ; these are given boundary values. There remains

$$\frac{2}{3}u_{11} - 3u_{12} = 1 + 1 = 2.$$

Our three equations for the three unknowns have the solution

$$u_{11} = -1.5, \quad u_{21} = -1, \quad u_{12} = -1.$$

### SECTION 21.6. Methods for Parabolic PDEs, page 922

**Purpose.** To show the numerical solution of the heat equation, the prototype of a parabolic equation, on the region given by  $0 \leq x \leq 1$ ,  $t \geq 0$ , subject to one initial condition (initial temperature) and one boundary condition on each of the two vertical boundaries.

#### Content

Direct method based on (5), convergence condition (6)

Crank–Nicolson method based on (8)

Special case (9) of (8)

#### Comment on Content

Condition (6) restricts the size of time steps too much, a disadvantage that the Crank–Nicolson method avoids.

### SOLUTIONS TO PROBLEM SET 21.6, page 927

4. 0, 0.6625, 1.25, 1.7125, 2, 2.1, 2, 1.7125, 1.25, 0.6625, 0

6. Note that  $h = 0.2$  and  $k = 0.01$  gives  $r = 0.25$ . The computation gives

| $t$  | $x = 0.2$ | $x = 0.4$ | $x = 0.6$ | $x = 0.8$ |
|------|-----------|-----------|-----------|-----------|
| 0.00 | 0.2       | 0.4       | 0.4       | 0.2       |
| 0.01 | 0.2       | 0.35      | 0.35      | 0.2       |
| 0.02 | 0.1875    | 0.3125    | 0.3125    | 0.185     |
| 0.03 | 0.171875  | 0.281250  | 0.281250  | 0.171875  |
| 0.04 | 0.156250  | 0.253906  | 0.253906  | 0.156250  |
| 0.05 | 0.141602  | 0.229492  | 0.229492  | 0.141602  |
| 0.06 | 0.128174  | 0.207520  | 0.207520  | 0.128174  |
| 0.07 | 0.115967  | 0.187684  | 0.187684  | 0.115967  |
| 0.08 | 0.104905  | 0.169755  | 0.169755  | 0.104905  |

8. We have  $k = 0.01$ . The boundary condition on the left is that the normal derivative is zero. Now if we were at an inner point, we would have, by (5),

$$u_{0,j+1} = \frac{1}{4}u_{-1,j} + \frac{1}{2}u_{0j} + \frac{1}{4}u_{1j}.$$

Here, by the central difference formula for the normal derivative (partial derivative with respect to  $x$ ) we get

$$0 = \frac{\partial u_{0j}}{\partial x} = \frac{1}{2h}(u_{1j} - u_{-1,j})$$

so that the previous formula gives what we need,

$$u_{0,j+1} = \frac{1}{2}(u_{0j} + u_{1j}).$$

The underlying idea is quite similar to that in Sec. 21.5. The computation gives

| $t$  | $x = 0$ | $x = 0.2$ | $x = 0.4$ | $x = 0.6$ | $x = 0.8$ | $x = 1$    |
|------|---------|-----------|-----------|-----------|-----------|------------|
| 0    | 0       | 0         | 0         | 0         | 0         | 0          |
| 0.01 | 0       | 0         | 0         | 0         | 0         | 0.5        |
| 0.02 | 0       | 0         | 0         | 0         | 0.125     | 0.866 025  |
| 0.03 | 0       | 0         | 0         | 0.031     | 0.279     | 1          |
| 0.04 | 0       | 0         | 0.008     | 0.085     | 0.397     | 0.866 025  |
| 0.05 | 0       | 0.002     | 0.025     | 0.144     | 0.437     | 0.5        |
| 0.06 | 0.001   | 0.007     | 0.049     | 0.187     | 0.379     | 0          |
| 0.07 | 0.004   | 0.016     | 0.073     | 0.201     | 0.236     | -0.5       |
| 0.08 | 0.010   | 0.027     | 0.091     | 0.178     | 0.043     | -0.866 025 |
| 0.09 | 0.019   | 0.039     | 0.097     | 0.122     | -0.150    | -1         |
| 0.10 | 0.029   | 0.048     | 0.089     | 0.048     | -0.295    | -0.866 025 |
| 0.11 | 0.039   | 0.054     | 0.068     | -0.028    | -0.352    | -0.5       |
| 0.12 | 0.046   | 0.054     | 0.041     | -0.085    | -0.308    | 0          |

10.  $u(x, 0) = u(1 - x, 0)$  and the boundary conditions imply  $u(x, t) = u(1 - x, t)$  for all  $t$ . The calculation gives

$$(0, 0.2, 0.35, 0.35, 0.2, 0)$$

$$(0, 0.1875, 0.3125, 0.3125, 0.1875, 0)$$

$$(0, 0.171875, 0.28125, 0.28125, 0.171875, 0)$$

$$(0, 0.15625, 0.253906, 0.253906, 0.15625, 0)$$

$$(0, 0.141602, 0.229492, 0.229492, 0.141602, 0)$$

12. **CAS Experiment.**  $u(0, t) = u(1, t) = 0$ ,  $u(0.2, t) = u(0.8, t)$ ,  $u(0.4, t) = u(0.6, t)$ , where

|            | $x = 0.2$ | $x = 0.4$ |            |
|------------|-----------|-----------|------------|
| $t = 0$    | 0.587785  | 0.951057  |            |
| $t = 0.04$ | 0.393432  | 0.636586  | Explicit   |
|            | 0.399274  | 0.646039  | CN         |
|            | 0.396065  | 0.640846  | Exact (6D) |
| $t = 0.08$ | 0.263342  | 0.426096  |            |
|            | 0.271221  | 0.438844  |            |
|            | 0.266878  | 0.431818  |            |

|            | $x = 0.2$ | $x = 0.4$ |
|------------|-----------|-----------|
| $t = 0.12$ | 0.176267  | 0.285206  |
|            | 0.184236  | 0.298100  |
|            | 0.179829  | 0.290970  |
| $t = 0.16$ | 0.117983  | 0.190901  |
|            | 0.125149  | 0.202495  |
|            | 0.121174  | 0.196063  |
| $t = 0.2$  | 0.078972  | 0.127779  |
|            | 0.085012  | 0.137552  |
|            | 0.081650  | 0.132112  |

14. We need the matrix

$$\mathbf{A} = \begin{bmatrix} 4 & -1 & 0 & 0 & 0 & 0 & 0 & 0 & 0 \\ -1 & 4 & -1 & 0 & 0 & 0 & 0 & 0 & 0 \\ 0 & -1 & 4 & -1 & 0 & 0 & 0 & 0 & 0 \\ 0 & 0 & -1 & 4 & -1 & 0 & 0 & 0 & 0 \\ 0 & 0 & 0 & -1 & 4 & -1 & 0 & 0 & 0 \\ 0 & 0 & 0 & 0 & -1 & 4 & -1 & 0 & 0 \\ 0 & 0 & 0 & 0 & 0 & -1 & 4 & -1 & 0 \\ 0 & 0 & 0 & 0 & 0 & 0 & -1 & 4 & -1 \\ 0 & 0 & 0 & 0 & 0 & 0 & 0 & -1 & 4 \end{bmatrix}.$$

3S-values computed by Crank–Nicolson for  $x = 0.1$  (and 0.9), 0.2 (and 0.8), 0.3 (and 0.7), 0.4 (and 0.6), 0.5 and  $t = 0.01, 0.02, \dots, 0.05$  are

|        |       |       |       |       |
|--------|-------|-------|-------|-------|
| 0.0754 | 0.141 | 0.190 | 0.220 | 0.230 |
| 0.0669 | 0.126 | 0.172 | 0.201 | 0.210 |
| 0.0600 | 0.114 | 0.156 | 0.183 | 0.192 |
| 0.0541 | 0.103 | 0.141 | 0.166 | 0.174 |
| 0.0490 | 0.093 | 0.128 | 0.150 | 0.158 |

5S-values for  $t = 0.04$  are

|          |         |         |         |          |
|----------|---------|---------|---------|----------|
| 0.054120 | 0.10277 | 0.14117 | 0.16568 | 0.17409. |
|----------|---------|---------|---------|----------|

The corresponding values in Prob. 13 are

|         |          |
|---------|----------|
| 0.10182 | 0.16727. |
|---------|----------|

Exact 5S-values computed by (9) and (10) in Sec. 12.5 (two nonzero terms suffice) are

|          |         |         |         |          |
|----------|---------|---------|---------|----------|
| 0.053947 | 0.10245 | 0.14074 | 0.16519 | 0.17359. |
|----------|---------|---------|---------|----------|

We see that the present values are better than those in Prob. 13.

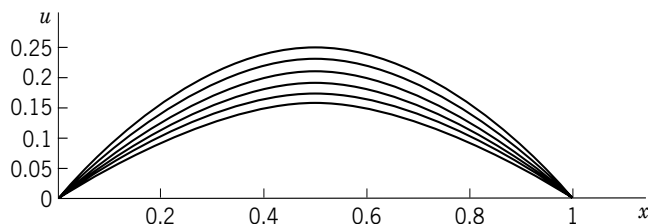

**Section 21.6.**  $u(x, t)$  for constant  $t = 0.01, \dots, 0.05$  as polygons with the Crank–Nicolson values as vertices in Problem 14

### SECTION 21.7. Method for Hyperbolic PDEs, page 928

**Purpose.** Explanation of the numerical solution of the wave equation, the prototype of a hyperbolic PDE, on a region of the same type as in the last section, subject to initial and boundary conditions that guarantee the uniqueness of the solution.

#### Comments on Content

We now have two initial conditions (given initial displacement and given initial velocity), in contrast to the heat equation in the last section, where we had only one initial condition.

The computation by (6) is simple. Formula (8) gives the values of the first time-step in terms of the initial data.

### SOLUTIONS TO PROBLEM SET 21.7, page 930

2. Note that the curve of  $f(x)$  is no longer symmetric with respect to  $x = 0.5$ . The solution was required for  $0 \leq t \leq 1$ . We present it here for a full cycle  $0 \leq t \leq 2$ :

| $t$ | $x = 0.2$ | $x = 0.4$ | $x = 0.6$ | $x = 0.8$ |
|-----|-----------|-----------|-----------|-----------|
| 0   | 0.032     | 0.096     | 0.144     | 0.128     |
| 0.2 | 0.048     | 0.088     | 0.112     | 0.072     |
| 0.4 | 0.056     | 0.064     | 0.016     | -0.016    |
| 0.6 | 0.016     | -0.016    | -0.064    | -0.056    |
| 0.8 | -0.072    | -0.112    | -0.088    | -0.048    |
| 1.0 | -0.128    | -0.144    | -0.096    | -0.032    |
| 1.2 | -0.072    | -0.112    | -0.088    | -0.048    |
| 1.4 | 0.016     | -0.016    | -0.064    | -0.056    |
| 1.6 | 0.056     | 0.064     | 0.016     | -0.016    |
| 1.8 | 0.048     | 0.088     | 0.112     | 0.072     |
| 2.0 | 0.032     | 0.096     | 0.144     | 0.128     |

4. By (13), Sec. 12.4, with  $c = 1$  the left side of (6) is

$$(A) \quad u_{i,j+1} = u(ih, (j+1)h) = \frac{1}{2}[f(ih + (j+1)h) + f(ih - (j+1)h)]$$

and the right side is the sum of the six terms

$$\begin{aligned} u_{i-1,j} &= \frac{1}{2}[f((i-1)h + jh) + f((i-1)h - jh)], \\ u_{i+1,j} &= \frac{1}{2}[f((i+1)h + jh) + f((i+1)h - jh)], \\ -u_{i,j-1} &= -\frac{1}{2}[f(ih + (j-1)h) + f(ih - (j-1)h)]. \end{aligned}$$

Four of these six terms cancel in pairs, and the remaining expression equals the right side of (A).

6. From (12), Sec. 12.4, with  $c = 1$  we get the exact solution

$$u(x, t) = \frac{1}{2} \int_{x-ct}^{x+ct} \sin \pi s \, ds = \frac{1}{2\pi} [\cos \pi(x - ct) - \cos \pi(x + ct)].$$

From (8) we have  $kg_i = 0.1g_i = 0.1 \sin 0.1\pi i$ . Because of the symmetry with respect to  $x = 0.5$  we need to list only the following values (with the exact values in parentheses):

| $t$ | $x = 0.1$              | $x = 0.2$              | $x = 0.3$              | $x = 0.4$              | $x = 0.5$              |
|-----|------------------------|------------------------|------------------------|------------------------|------------------------|
| 0.0 | 0                      | 0                      | 0                      | 0                      | 0                      |
| 0.1 | 0.030902<br>(0.030396) | 0.058779<br>(0.057816) | 0.080902<br>(0.079577) | 0.095106<br>(0.093549) | 0.100000<br>(0.098363) |
| 0.2 | 0.058779<br>(0.057816) | 0.111804<br>(0.109973) | 0.153885<br>(0.151365) | 0.180902<br>(0.177941) | 0.190212<br>(0.187098) |
| 0.3 | 0.080902<br>(0.079577) | 0.153884<br>(0.151365) | 0.211803<br>(0.208337) | 0.248990<br>(0.244914) | 0.261803<br>(0.257518) |
| 0.4 | 0.095106<br>(0.093549) | 0.180902<br>(0.177941) | 0.248990<br>(0.244914) | 0.292705<br>(0.287914) | 0.307768<br>(0.302731) |

8. Since  $u(x, 0) = f(x)$ , the derivation is immediate. Formula (8) results if the integral equals  $2kg_i$ .
10. Exact solution:  $u(x, t) = (x + t)^2$ . The values obtained in the computation are those of the exact solution.  $u_{11}, u_{21}, u_{31}, u_{41}$  are obtained from (8) and the initial conditions  $u_{i0} = (0.2i)^2$ ,  $g_i = 0.2i$ . In connection with the left boundary condition we can use the central difference formula

$$\frac{1}{2h} (u_{1,j} - u_{-1,j}) \approx u_x(0, jk) = 2jk$$

to obtain  $u_{-1,j}$  and then (8) to compute  $u_{01}$  and (6) to compute  $u_{0,j+1}$ .

### SOLUTIONS TO CHAP. 21 REVIEW QUESTIONS AND PROBLEMS, page 930

16.  $y = e^{x^2}$ . The computation is:

| $x_n$ | $y_n$  | Error  |
|-------|--------|--------|
| 0.1   | 1      | 0.0101 |
| 0.2   | 1.02   | 0.0208 |
| 0.3   | 1.0608 | 0.0334 |
| 0.4   | 1.1244 | 0.0491 |
| 0.5   | 1.2144 | 0.0696 |
| 0.6   | 1.3358 | 0.0975 |
| 0.7   | 1.4961 | 0.1362 |
| 0.8   | 1.7056 | 0.1909 |
| 0.9   | 1.9785 | 0.2694 |
| 1.0   | 2.3346 | 0.3837 |

This illustrates again that the method is too inaccurate for most practical purposes.

18.  $y = \tan x - x + 4$ ;  $y = 4$ , 4.002707, 4.022789, 4.084133, 4.229637, 4.557352, 5.370923, 8.341089. For  $x \leq 1.0$  the error is of the order  $10^{-5}$ , but then  $\epsilon(1.2) = 10^{-3}$ ,  $\epsilon(1.4) = 0.06$  since we are getting close to  $\pi/2$ .
20. (a) 0.1, 0.2034, 0.3109, 0.4217, 0.5348, 0.6494, 0.7649, 0.8806, error 0.0044, 0.0122,  $\dots$ , 0.0527. (b) 0.2055, 0.4276, 0.6587, 0.8924, error 0.0101, 0.0221, 0.0322, 0.0409. (c) 0.4352, 0.9074, error 0.0145, 0.0258
22.  $y = \tan x - x$ . The computation is:

| $x_n$ | $y_n$      | Error $\cdot 10^5$ |
|-------|------------|--------------------|
| 0.2   | 0.00270741 | 0.26               |
| 0.4   | 0.0227890  | 0.40               |
| 0.6   | 0.0841334  | 0.34               |
| 0.8   | 0.229637   | 0.24               |
| 1.0   | 0.557352   | 5.6                |

24.  $y_1 = 0.021400$  (starting value),  $y_2 = 0.092322$ ,  $y_3 = 0.223342$ ,  $y_4 = 0.427788$ ,  $y_5 = 0.721945$ . This shows that the method is rather inaccurate, the error of  $y_5$  being 0.003663. Exact:  $y = e^x - x - 1$ .
26.  $y = \sin x$ . The computation is:

| $x_n$ | $y_n$    | Error $\cdot 10^5$ |
|-------|----------|--------------------|
| 0.2   | 0.198667 | 0.2                |
| 0.4   | 0.389413 | 0.5                |
| 0.6   | 0.564635 | 0.7                |
| 0.8   | 0.717347 | 0.9                |
| 1.0   | 0.841461 | 1.0                |

28. The solution is  $y_1 = 3e^{-2x} - e^{-8x}$ ,  $y_2 = 3e^{-2x} + e^{-8x}$ . The computation gives:

| $x_n$ | $y_{1,n}$ | Error   | $y_{2,n}$ | Error    |
|-------|-----------|---------|-----------|----------|
| 0.1   | 2.00447   | 0.00239 | 2.90793   | -0.00241 |
| 0.2   | 1.80691   | 0.00215 | 2.21504   | -0.00218 |
| 0.3   | 1.55427   | 0.00145 | 1.73863   | -0.00147 |
| 0.4   | 1.30636   | 0.00087 | 1.38965   | -0.00090 |
| 0.5   | 1.08484   | 0.00048 | 1.12247   | -0.00051 |

30.  $u(P_{11}) = u(P_{22}) = u(P_{33}) = 35$ ,  $u(P_{21}) = u(P_{32}) = 20$ ,  $u(P_{31}) = 10$ ,  $u(P_{12}) = u(P_{23}) = 50$ ,  $u(P_{13}) = 60$
32.  $u(P_{21}) = 500$ ,  $u(P_{22}) = 200$ ,  $u = 100$  at all other gridpoints
36. From the 3D-values given below we see that at each point  $x > 0$  the temperature oscillates with a phase lag and a maximum amplitude that decreases with decreasing  $x$ .

| $t$  | $x = 0$ | $x = 0.2$ | $x = 0.4$ | $x = 0.6$ | $x = 0.8$ | $x = 1.0$ |
|------|---------|-----------|-----------|-----------|-----------|-----------|
| 0    | 0       | 0         | 0         | 0         | 0         | 0         |
| 0.02 | 0       | 0         | 0         | 0         | 0         | 0.5       |
| 0.04 | 0       | 0         | 0         | 0         | 0.250     | 0.866025  |
| 0.06 | 0       | 0         | 0         | 0.125     | 0.433     | 1         |
| 0.08 | 0       | 0         | 0.062     | 0.217     | 0.562     | 0.866025  |
| 0.10 | 0       | 0.031     | 0.108     | 0.312     | 0.541     | 0.5       |
| 0.12 | 0       | 0.054     | 0.172     | 0.325     | 0.406     | 0         |
| 0.14 | 0       | 0.086     | 0.189     | 0.289     | 0.162     | -0.5      |
| 0.16 | 0       | 0.095     | 0.188     | 0.176     | -0.105    | -0.866025 |
| 0.18 | 0       | 0.094     | 0.135     | 0.041     | -0.345    | -1        |
| 0.20 | 0       | 0.068     | 0.067     | -0.105    | -0.479    | -0.866025 |
| 0.22 | 0       | 0.034     | -0.019    | -0.206    | -0.485    | -0.5      |
| 0.24 | 0       | -0.009    | -0.086    | -0.252    | -0.353    | 0         |

38.  $u(x, t)$  in Prob. 37 equals  $u(x, t) - u(1 - x, t)$  in Prob. 36, as follows from the boundary values.
40. We have to calculate values for three time-steps. The result is as follows, where  $u(x, t) = u(1 - x, t)$ .

| $t$ | $x = 0$ | $x = 0.1$ | $x = 0.2$ | $x = 0.3$ | $x = 0.4$ | $x = 0.5$ |
|-----|---------|-----------|-----------|-----------|-----------|-----------|
| 0   | 0       | 0.09      | 0.16      | 0.21      | 0.24      | 0.25      |
| 0.1 | 0       | 0.08      | 0.15      | 0.20      | 0.23      | 0.24      |
| 0.2 | 0       | 0.06      | 0.12      | 0.17      | 0.20      | 0.21      |
| 0.3 | 0       | 0.04      | 0.08      | 0.12      | 0.15      | 0.16      |



## Part F. Optimization. Graphs

### CHAPTER 22 Unconstrained Optimization. Linear Programming

#### SECTION 22.1. Basic Concepts. Unconstrained Optimization, page 936

**Purpose.** To explain the concepts needed throughout this chapter. To discuss Cauchy's method of steepest descent or gradient method, a popular method of unconstrained optimization.

#### Main Content, Important Concepts

Objective function  
Control variables  
Constraints, unconstrained optimization  
Cauchy's method

#### SOLUTIONS TO PROBLEM SET 22.1, page 939

2. The line of approach is tangent to a particular curve  $C: f(\mathbf{x}) = \text{const}$ , the point of contact  $P$  giving the minimum, whereas the next gradient of  $C$  at  $P$  is perpendicular to  $C$ .
4.  $f(\mathbf{x}) = (x_1 - 0.5)^2 + 2(x_2 - 1.5)^2 - 4.75$ . The computation gives:

| Step | $x_1$   | $x_2$  | $f(\mathbf{x})$ |
|------|---------|--------|-----------------|
| 1    | 0.25342 | 1.5206 | -4.6884         |
| 2    | 0.49351 | 1.4805 | -4.7492         |
| 3    | 0.49680 | 1.5003 | -4.7500         |

6.  $f(\mathbf{x}) = (x_1 + 4)^2 + 0.1(x_2 + 5)^2 + 4$ . The computation gives:

| Step | $x_1$   | $x_2$   | $f(\mathbf{x})$ |
|------|---------|---------|-----------------|
| 1    | -4.0240 | -1.4016 | 5.2958          |
| 2    | -3.7933 | -4.8622 | 4.0449          |
| 3    | -4.0008 | -4.8760 | 4.0015          |
| 4    | -3.9929 | -4.9952 | 4.0000          |
| 5    | -4.0000 | -4.9957 | 4.0000          |
| 6    | -3.9997 | -5.0000 | 4.0000          |
| 7    | -4.0000 | -5.0000 | 4.0000          |

8. The calculation gives for Steps 1–5:

| $x_1$    | $x_2$    | $f(\mathbf{x})$ |
|----------|----------|-----------------|
| -1.33333 | 2.66667  | -5.3334         |
| -3.55556 | -1.77778 | 9.4815          |
| 2.37037  | -4.74074 | -16.8560        |
| 6.32099  | 3.16049  | 29.9662         |
| -4.21399 | 8.42798  | -53.2731        |

This is the beginning of a broken line of segments spiraling away from the origin. At the corner points,  $f$  is alternately positive and negative and increases monotone in absolute value.

10.  $f(\mathbf{x}) = x_1^2 - x_2$  gives

$$\mathbf{z}(t) = \mathbf{x} - t[2x_1, -1] = [(1 - 2t)x_1, x_2 + t],$$

hence

$$\begin{aligned} g(t) &= (1 - 2t)^2 x_1^2 - x_2 - t, \\ g'(t) &= -4(1 - 2t)x_1^2 - 1 = 0. \end{aligned}$$

From this,

$$1 - 2t = -\frac{1}{4x_1^2}, \quad t = \frac{1}{2} + \frac{1}{8x_1^2}.$$

For this  $t$ ,

$$\mathbf{z}(t) = \left[ -\frac{1}{4x_1}, x_2 + \frac{1}{2} + \frac{1}{8x_1^2} \right].$$

From this, with  $x_1 = 1$ ,  $x_2 = 1$ , we get successively

$$\begin{aligned} \mathbf{z}_{(1)} &= \left[ -\frac{1}{4}, 1 + \frac{1}{2} + \frac{1}{8} \right]^T \\ \mathbf{z}_{(2)} &= \left[ 1, 1 + 2 \cdot \frac{1}{2} + \frac{1}{8} + 2 \right]^T \\ \mathbf{z}_{(3)} &= \left[ -\frac{1}{4}, 1 + 3 \cdot \frac{1}{2} + 2 \cdot \frac{1}{8} + 2 \right]^T \quad \text{etc.} \end{aligned}$$

The student should sketch this, to see that it is reasonable. The process continues indefinitely, as had to be expected.

12. **CAS Experiment.** (c) For  $f(\mathbf{x}) = x_1^2 + x_2^4$  the values converge relatively rapidly to  $[0 \ 0]^T$ , and similarly for  $f(\mathbf{x}) = x_1^4 + x_2^4$ .

## SECTION 22.2. Linear Programming, page 939

**Purpose.** To discuss the basic ideas of linear programming in terms of very simple examples involving two variables, so that the situation can be handled graphically and the solution can be found geometrically. To prepare conceptually for the case of three or more variables  $x_1, \dots, x_n$ .

### Main Content, Important Concepts

- Linear programming problem
- Its normal form. Slack variables
- Feasible solution, basic feasible solution
- Optimal solution

### Comments on Content

Whereas the function to be maximized (or minimized) by Cauchy's method was arbitrary (differentiable), but we had no constraints, we now simply have a linear objective function, but constraints, so that calculus no longer helps.

No systematic method of solution is discussed in this section; these follow in the next sections.

**SOLUTIONS TO PROBLEM SET 22.2, page 943**

2. No. For instance,  $f = 5x_1 + 2x_2$  gives maximum profit  $f = 12$  for every point on the segment  $AB$  because  $AB$  has the same slope as  $f = \text{const}$  does.
4. Nonnegativity is an immediate consequence of the definition of a slack variable. We need as many slack variables as we have inequalities that we want to convert into equations, with each one giving one of the constraints.
8. Ordinarily a vertex of a region is the intersection of only *two* straight lines given by inequalities taken with the equality sign. Here,  $(5, 4)$  is the intersection of *three* such lines. This may merit special attention in some cases, as we discuss in Sec. 22.4.
10. The first inequality could be dropped from the problem because it does not restrict the region determined by the other inequalities. Note that that region is unbounded (stretches to infinity). This would cause a problem in maximizing an objective function with positive coefficients.
12.  $f_{\max} = -18$  at every point of the segment with endpoints  $(2/9, 28/9)$  and  $(4, 5)$
14.  $f_{\min} = f(3/7, 24/7) = 78/7 = 11.14$
16.  $f = x_1 + x_2, 2x_1 + 3x_2 \leq 1200, 4x_1 + 2x_2 \leq 1600, x_1 = 300, x_2 = 200,$   
 $f_{\max} = f(300, 200) = 500$
18.  $x_1 =$  Number of days of operation of Kiln I,  $x_2 =$  Number of days of operation of Kiln II. Objective function  $f = 400x_1 + 600x_2$ . Constraints:

$$3000x_1 + 2000x_2 \geq 18000 \quad (\text{Gray bricks})$$

$$2000x_1 + 5000x_2 \geq 34000 \quad (\text{Red bricks})$$

$$300x_1 + 1500x_2 \geq 9000 \quad (\text{Glazed bricks}).$$

$f_{\min} = f(2, 6) = 4400$ , as can be seen from a sketch of the region in the  $x_1x_2$ -plane resulting from the constraints in the first quadrant. Operate Kiln I two days and Kiln II six days in filling that order. Note that the region determined by the constraints in the first quadrant of the  $x_1x_2$ -plane is unbounded, which causes no difficulty because we minimize (not maximize) the objective function.

20.  $x_1$  units of  $A$  and  $x_2$  units of  $B$  cost  $f = 1.8x_1 + 2.1x_2$ . Constraints are

$$15x_1 + 30x_2 \geq 150 \quad (\text{Protein})$$

$$600x_1 + 500x_2 \geq 3900 \quad (\text{Calories}).$$

From a sketch of the region we see that  $f_{\min} = f(4, 3) = 13.50$ . Hence the minimum-cost diet consists of 4 units  $A$  and 3 units  $B$ .

**SECTION 22.3. Simplex Method, page 944**

**Purpose.** To discuss the standard method of linear programming for systematically finding an optimal solution by a finite sequence of transformations of matrices.

**Main Content, Important Concepts**

Normal form of the problem

Initial simplex table (initial augmented matrix)

Pivoting, further simplex tables (augmented matrices)

**Comment on Concepts and Method**

The given form of the problem involves inequalities. By introducing slack variables we convert the problem to the normal form. This is a linear system of equations. The initial simplex table is its augmented matrix. It is transformed by first selecting the column of a pivot and then the row of that pivot. The rules for this are entirely different from those for pivoting in connection with solving a linear system of equations. The selection of a pivot is followed by a process of elimination by row operations similar to that in the Gauss–Jordan method (Sec. 7.8). This is the first step, leading to another simplex table (another augmented matrix). The next step is done by the same rules, and so on. The process comes to an end when the first row of the simplex table obtained contains no more negative entries. From this final simplex table one can read the optimal solution of the problem because the first row corresponds to the objective function  $f(x)$  to be maximized (or minimized).

**SOLUTIONS TO PROBLEM SET 22.3, page 946**

2. From the given data we have the augmented matrix (the initial simplex table)

$$\mathbf{T}_0 = \begin{bmatrix} 1 & -1 & -1 & 0 & 0 & 0 \\ 0 & 2 & 3 & 1 & 0 & 1200 \\ 0 & 4 & 2 & 0 & 1 & 1600 \end{bmatrix}.$$

The pivot is 4 since  $1600/4 < 1200/2$ . The indicated calculations give

$$\mathbf{T}_1 = \begin{bmatrix} 1 & 0 & -\frac{1}{2} & 0 & \frac{1}{4} & 400 \\ 0 & 0 & 2 & 1 & -\frac{1}{2} & 400 \\ 0 & 4 & 2 & 0 & 1 & 1600 \end{bmatrix} \quad \begin{array}{l} \text{Row 1} + \frac{1}{4} \text{ Row 3} \\ \text{Row 2} - \frac{2}{4} \text{ Row 3} \\ \text{Row 3.} \end{array}$$

The pivot is 2 in Row 2. The indicated calculations give

$$\mathbf{T}_2 = \begin{bmatrix} 1 & 0 & 0 & \frac{1}{4} & \frac{1}{8} & 500 \\ 0 & 0 & 2 & 1 & -\frac{1}{2} & 400 \\ 0 & 4 & 0 & -1 & \frac{3}{2} & 1200 \end{bmatrix} \quad \begin{array}{l} \text{Row 1} + \frac{1}{4} \text{ Row 2} \\ \text{Row 2} \\ \text{Row 3} - \frac{2}{2} \text{ Row 2.} \end{array}$$

This shows that the solution is

$$f\left(\frac{1200}{4}, \frac{400}{2}\right) = 500.$$

4. From the given data we obtain the augmented matrix

$$\mathbf{T}_0 = \begin{bmatrix} 1 & -2 & -3 & -1 & 0 & 0 & 0 & 0 \\ 0 & 1 & 1 & 1 & 1 & 0 & 0 & 4.8 \\ 0 & 10 & 0 & 1 & 0 & 1 & 0 & 9.9 \\ 0 & 0 & 1 & -1 & 0 & 0 & 1 & 0.2 \end{bmatrix}.$$

The pivot is 10. The indicated calculations give

$$\mathbf{T}_1 = \begin{bmatrix} 1 & 0 & -3 & -\frac{4}{5} & 0 & \frac{1}{5} & 0 & 1.98 \\ 0 & 0 & 1 & \frac{9}{10} & 1 & -\frac{1}{10} & 0 & 3.81 \\ 0 & 10 & 0 & 1 & 0 & 1 & 0 & 9.9 \\ 0 & 0 & 1 & -1 & 0 & 0 & 1 & 0.2 \end{bmatrix} \begin{array}{l} \text{Row 1} + \frac{2}{10} \text{ Row 3} \\ \text{Row 2} - \frac{1}{10} \text{ Row 3} \\ \text{Row 3} \\ \text{Row 4} \end{array}$$

The next pivot is 1 in Row 4 and Column 3. The indicated calculations give

$$\mathbf{T}_2 = \begin{bmatrix} 1 & 0 & 0 & -\frac{19}{5} & 0 & \frac{1}{5} & 3 & 2.58 \\ 0 & 0 & 0 & \frac{19}{10} & 1 & -\frac{1}{10} & -1 & 3.61 \\ 0 & 10 & 0 & 1 & 0 & 1 & 0 & 9.9 \\ 0 & 0 & 1 & -1 & 0 & 0 & 1 & 0.2 \end{bmatrix} \begin{array}{l} \text{Row 1} + 3 \text{ Row 4} \\ \text{Row 2} - \text{Row 4} \\ \text{Row 3} \\ \text{Row 4} \end{array}$$

The last pivot needed is  $19/10$  in Row 2 and Column 4. We obtain

$$\mathbf{T}_3 = \begin{bmatrix} 1 & 0 & 0 & 0 & 2 & 0 & 1 & 9.8 \\ 0 & 0 & 0 & \frac{19}{10} & 1 & -\frac{1}{10} & -1 & 3.61 \\ 0 & 10 & 0 & 0 & -\frac{10}{19} & \frac{20}{19} & \frac{10}{19} & 8 \\ 0 & 0 & 1 & 0 & \frac{10}{19} & -\frac{1}{19} & \frac{9}{19} & 2.1 \end{bmatrix} \begin{array}{l} \text{Row 1} + 2 \text{ Row 2} \\ \text{Row 2} \\ \text{Row 3} - \frac{10}{19} \text{ Row 2} \\ \text{Row 4} + \frac{10}{19} \text{ Row 2} \end{array}$$

Hence a solution of our problem is

$$f\left(\frac{8}{10}, \frac{2.1}{1}, \frac{3.61}{19/10}\right) = f(0.8, 2.1, 1.9) = 9.8.$$

Actually, all solutions are

$$(x_1, 2.5 - 0.5x_1, 2.3 - 0.5x_1)$$

where  $x_1$  is arbitrary, satisfying  $0 \leq x_1 \leq 0.8$ , thus giving a straight segment with endpoints  $(0, 2.5, 2.3)$  and  $(0.8, 2.1, 1.9)$ , where  $x_1 = 0.8$  results from solving the system of three equations of the constraints taken with equality signs. The reason for the nonuniqueness is that the plane  $f(x_1, x_2, x_3) = 9.8$  contains an edge of the region to which  $x_1, x_2, x_3$  are restricted, whereas in general it will have just a single point (a vertex) in common with that region.

6. The matrices and pivot selections are

$$\mathbf{T}_0 = \begin{bmatrix} 1 & -4 & 10 & 20 & 0 & 0 & 0 & 0 \\ 0 & 3 & 4 & 5 & 1 & 0 & 0 & 60 \\ 0 & 2 & 1 & 0 & 0 & 1 & 0 & 20 \\ 0 & 2 & 0 & 3 & 0 & 0 & 1 & 30 \end{bmatrix}$$

$60/4 = 15 < 20/1 = 20$ , pivot 4

$$\mathbf{T}_1 = \begin{bmatrix} 1 & -\frac{23}{2} & 0 & \frac{15}{2} & -\frac{5}{2} & 0 & 0 & -150 \\ 0 & 3 & 4 & 5 & 1 & 0 & 0 & 60 \\ 0 & \frac{5}{4} & 0 & -\frac{5}{4} & -\frac{1}{4} & 1 & 0 & 5 \\ 0 & 2 & 0 & 3 & 0 & 0 & 1 & 30 \end{bmatrix} \begin{array}{l} \text{Row 1} - \frac{10}{4} \text{ Row 2} \\ \text{Row 2} \\ \text{Row 3} - \frac{1}{4} \text{ Row 2} \\ \text{Row 4} \end{array}$$

$60/5 > 30/3$ , pivot 3

$$\mathbf{T}_2 = \begin{bmatrix} 1 & -\frac{33}{2} & 0 & 0 & -\frac{5}{2} & 0 & -\frac{5}{2} & -225 \\ 0 & -\frac{1}{3} & 4 & 0 & 1 & 0 & -\frac{5}{3} & 10 \\ 0 & \frac{25}{12} & 0 & 0 & -\frac{1}{4} & 1 & \frac{5}{12} & \frac{35}{2} \\ 0 & 2 & 0 & 3 & 0 & 0 & 1 & 30 \end{bmatrix} \begin{array}{l} \text{Row 1} - \frac{15}{6} \text{ Row 4} \\ \text{Row 2} - \frac{5}{3} \text{ Row 4} \\ \text{Row 3} + \frac{5}{12} \text{ Row 4} \\ \text{Row 4} \end{array}$$

$f_{\min} = -225$  at  $x_1 = 0$ ,  $x_2 = 10/4 = 2.5$ ,  $x_3 = 30/3 = 10$ .

8. We minimize! The augmented matrix is

$$\mathbf{T}_0 = \begin{bmatrix} 1 & 1.8 & 2.1 & 0 & 0 & 0 \\ 0 & 15 & 30 & 1 & 0 & 150 \\ 0 & 600 & 500 & 0 & 1 & 3900 \end{bmatrix}.$$

The pivot is 600. The calculation gives

$$\mathbf{T}_1 = \begin{bmatrix} 1 & 0 & \frac{6}{10} & 0 & -\frac{3}{1000} & -\frac{117}{10} \\ 0 & 0 & \frac{35}{2} & 1 & -\frac{1}{40} & \frac{105}{2} \\ 0 & 600 & 500 & 0 & 1 & 3900 \end{bmatrix} \begin{array}{l} \text{Row 1} - \frac{1.8}{600} \text{ Row 3} \\ \text{Row 2} - \frac{15}{600} \text{ Row 3} \\ \text{Row 3} \end{array}$$

The next pivot is  $35/2$ . The calculation gives

$$\mathbf{T}_2 = \begin{bmatrix} 1 & 0 & 0 & -\frac{6}{175} & -\frac{3}{1400} & -\frac{27}{2} \\ 0 & 0 & \frac{35}{2} & 1 & -\frac{1}{40} & \frac{105}{2} \\ 0 & 600 & 0 & -\frac{200}{7} & \frac{12}{7} & 2400 \end{bmatrix} \begin{array}{l} \text{Row 1} - \frac{1.2}{35} \text{ Row 2} \\ \text{Row 2} \\ \text{Row 3} - \frac{1000}{35} \text{ Row 2} \end{array}$$

Hence  $-f$  has the maximum value  $-13.5$ , so that  $f$  has the minimum value  $13.5$ , at the point

$$(x_1, x_2) = \left( \frac{2400}{600}, \frac{105/2}{35/2} \right) = (4, 3).$$

### SECTION 22.4. Simplex Method: Difficulties, page 947

**Purpose.** To explain ways of overcoming difficulties that may arise in applying the simplex method.

#### Main Content, Important Concepts

Degenerate feasible solution

Artificial variable (for overcoming difficulties in starting)

**Short Courses.** Omit this section because these difficulties occur only quite infrequently in practice.

**SOLUTIONS TO PROBLEM SET 22.4, page 952**

2. In the second step in Prob. 1 we had a choice of the pivot, and in the present problem, owing to our rule of choice, we took the other pivot. The result remained the same. Of course, the problem can be solved by inspection. The calculation is as follows.

$$\mathbf{T}_0 = \begin{bmatrix} 1 & -6 & -12 & 0 & 0 & 0 & 0 \\ 0 & 1 & 0 & 1 & 0 & 0 & 4 \\ 0 & 6 & 12 & 0 & 0 & 1 & 72 \\ 0 & 0 & 1 & 0 & 1 & 0 & 4 \end{bmatrix}$$

$$\mathbf{T}_1 = \begin{bmatrix} 1 & 0 & -12 & 6 & 0 & 0 & 24 \\ 0 & 1 & 0 & 1 & 0 & 0 & 4 \\ 0 & 0 & 12 & -6 & 0 & 1 & 48 \\ 0 & 0 & 1 & 0 & 1 & 0 & 4 \end{bmatrix} \begin{array}{l} \text{R1} + 6 \text{R2} \\ \text{R2} \\ \text{R3} - 6 \text{R2} \\ \text{R4} \end{array}$$

$$\mathbf{T}_2 = \begin{bmatrix} 1 & 0 & 0 & 0 & 0 & 1 & 72 \\ 0 & 1 & 0 & 1 & 0 & 0 & 4 \\ 0 & 0 & 12 & -6 & 0 & 1 & 48 \\ 0 & 0 & 0 & \frac{1}{2} & 1 & -\frac{1}{12} & 0 \end{bmatrix} \begin{array}{l} \text{R1} + \text{R3} \\ \text{R2} \\ \text{R3} \\ \text{R4} - \frac{1}{12} \text{R3} \end{array}$$

This gives  $x_1 = 4$ ,  $x_2 = 48/12 = 4$ ,  $x_3 = 0$ ,  $x_4 = 0$ ,  $x_5 = 0$ ,  $f(4, 4) = 72$ .

4. The calculation is as follows.

$$\mathbf{T}_0 = \begin{bmatrix} 1 & -300 & -500 & 0 & 0 & 0 & 0 \\ 0 & 2 & 8 & 1 & 0 & 0 & 60 \\ 0 & 2 & 1 & 0 & 1 & 0 & 30 \\ 0 & 4 & 4 & 0 & 0 & 1 & 60 \end{bmatrix}$$

$$\mathbf{T}_1 = \begin{bmatrix} 1 & 0 & -350 & 0 & 150 & 0 & 4500 \\ 0 & 0 & 7 & 1 & -1 & 0 & 30 \\ 0 & 2 & 1 & 0 & 1 & 0 & 30 \\ 0 & 0 & 2 & 0 & -2 & 1 & 0 \end{bmatrix} \begin{array}{l} \text{R1} + 150 \text{R3} \\ \text{R2} - \text{R3} \\ \text{R3} \\ \text{R4} - 2 \text{R3} \end{array}$$

$$\mathbf{T}_2 = \begin{bmatrix} 1 & 0 & 0 & 0 & -200 & 175 & 4500 \\ 0 & 0 & 0 & 1 & 6 & -\frac{7}{2} & 30 \\ 0 & 2 & 0 & 0 & 2 & -\frac{1}{2} & 30 \\ 0 & 0 & 2 & 0 & -2 & 1 & 0 \end{bmatrix} \begin{array}{l} \text{R1} + 175 \text{R4} \\ \text{R2} - \frac{7}{2} \text{R4} \\ \text{R3} - \frac{1}{2} \text{R4} \\ \text{R4} \end{array}$$

$z = 4500$  is the same as in the step before. But we shall now be able to reach the maximum  $f(10, 5) = 5500$  in the final step.

$$\mathbf{T}_3 = \begin{bmatrix} 1 & 0 & 0 & \frac{100}{3} & 0 & \frac{175}{3} & 5500 \\ 0 & 0 & 0 & 1 & 6 & -\frac{7}{2} & 30 \\ 0 & 2 & 0 & -\frac{1}{3} & 0 & \frac{2}{3} & 20 \\ 0 & 0 & 2 & \frac{1}{3} & 0 & -\frac{1}{6} & 10 \end{bmatrix} \begin{array}{l} \text{R1} + \frac{100}{3} \text{R2} \\ \text{R2} \\ \text{R3} - \frac{1}{3} \text{R2} \\ \text{R4} + \frac{1}{3} \text{R2} \end{array}$$

We see that  $x_1 = 20/2 = 10$ ,  $x_2 = 10/2 = 5$ ,  $x_3 = 0$ ,  $x_4 = 30/6 = 5$ ,  $x_5 = 0$ ,  $z = 5500$ .

Problem 5 shows that the extra step (which gave no increase of  $z = f(x)$ ) could have been avoided if we had chosen 4 (instead of 2) as the first pivot.

6. The maximum  $f(0, 2.4, 0) = 2.4$  is obtained as follows.

$$\mathbf{T}_0 = \begin{bmatrix} 1 & -1 & -1 & -1 & 0 & 0 & 0 \\ 0 & 4 & 5 & 8 & 1 & 0 & 12 \\ 0 & 8 & 5 & 4 & 0 & 1 & 12 \end{bmatrix}$$

$$\mathbf{T}_1 = \begin{bmatrix} 1 & 0 & -\frac{3}{8} & -\frac{1}{2} & 0 & \frac{1}{8} & \frac{3}{2} \\ 0 & 0 & \frac{5}{2} & 6 & 1 & -\frac{1}{2} & 6 \\ 0 & 8 & 5 & 4 & 0 & 1 & 12 \end{bmatrix} \begin{array}{l} \text{R1} + \frac{1}{8} \text{R3} \\ \text{R2} - \frac{1}{2} \text{R3} \\ \text{R3} \end{array}$$

$$\mathbf{T}_2 = \begin{bmatrix} 1 & 0 & 0 & \frac{2}{5} & \frac{3}{20} & \frac{1}{20} & \frac{12}{5} \\ 0 & 0 & \frac{5}{2} & 6 & 1 & -\frac{1}{2} & 6 \\ 0 & 8 & 0 & -8 & -2 & 2 & 0 \end{bmatrix} \begin{array}{l} \text{R1} + \frac{3}{20} \text{R2} \\ \text{R2} \\ \text{R3} - 2 \text{R2} \end{array}$$

From  $\mathbf{T}_2$  we see that  $x_1 = 0/8 = 0$ ,  $x_2 = 6/\frac{5}{2} = 12/5$ ,  $x_3 = 0$ ,  $x_4 = 0$ ,  $x_5 = 0$ ,  $z = 12/5$ .

8. Maximize  $\tilde{f} = -2x_1 + x_2$ . The result is  $-\tilde{f}_{\min} = \tilde{f}_{\max} = \tilde{f}(2, 3) = -1$ , hence  $f_{\min} = 1$ . The calculation is as follows. An artificial variable  $x_6$  is defined by

$$x_3 = -5 + x_1 + x_2 + x_6.$$

A corresponding objective function is

$$\tilde{f} = \tilde{f} - Mx_6 = (-2 + M)x_1 + (1 + M)x_2 - Mx_3 - 5M.$$

The corresponding matrix is

$$\mathbf{T}_0 = \begin{bmatrix} 1 & 2 - M & -1 - M & M & 0 & 0 & -5M \\ 0 & 1 & 1 & -1 & 0 & 0 & 5 \\ 0 & -1 & 1 & 0 & 1 & 0 & 1 \\ 0 & 5 & 4 & 0 & 0 & 1 & 40 \end{bmatrix}.$$



From this we obtain

$$\mathbf{T}_1 = \begin{bmatrix} 1 & 0 & -3 & 2 & 0 & 0 & -10 \\ 0 & 1 & 1 & -1 & 0 & 0 & 5 \\ 0 & 0 & 2 & -1 & 1 & 0 & 6 \\ 0 & 0 & -1 & 5 & 0 & 1 & 15 \end{bmatrix} \begin{array}{l} \text{R1} + (M - 2)\text{R2} \\ \text{R2} \\ \text{R3} + \text{R2} \\ \text{R4} - 5\text{R2} \end{array}$$

and

$$\mathbf{T}_2 = \begin{bmatrix} 1 & 0 & 0 & \frac{1}{2} & \frac{3}{2} & 0 & -1 \\ 0 & 1 & 0 & -\frac{1}{2} & -\frac{1}{2} & 0 & 2 \\ 0 & 0 & 2 & -1 & 1 & 0 & 6 \\ 0 & 0 & 0 & \frac{9}{2} & \frac{1}{2} & 1 & 18 \end{bmatrix} \begin{array}{l} \text{R1} + \frac{3}{2}\text{R3} \\ \text{R2} - \frac{1}{2}\text{R3} \\ \text{R3} \\ \text{R4} + \frac{1}{2}\text{R3} \end{array}$$

We see that  $x_1 = 2/1 = 2$ ,  $x_2 = 6/2 = 3$ ,  $x_3 = 0$ ,  $x_4 = 0$ ,  $x_5 = 18$ ,  $\hat{f} = -1$ .

10. An artificial variable  $x_6$  is defined by

$$x_4 = x_1 + 2x_2 - 6 + x_6$$

and a corresponding objective function by

$$\begin{aligned} \hat{f} &= 2x_1 + x_2 - Mx_6 = 2x_1 + x_2 - M(x_4 - x_1 - 2x_2 + 6) \\ &= (2 + M)x_1 + (1 + 2M)x_2 - Mx_4 - 6M. \end{aligned}$$

This gives the matrix

$$\mathbf{T}_0 = \begin{bmatrix} 1 & -2 - M & -1 - 2M & 0 & M & 0 & -6M \\ 0 & 2 & 1 & 1 & 0 & 0 & 2 \\ 0 & 1 & 2 & 0 & -1 & 0 & 6 \\ 0 & 1 & 1 & 0 & 0 & 1 & 4 \end{bmatrix}$$

and from it

$$\mathbf{T}_1 = \begin{bmatrix} 1 & 0 & -\frac{3}{2}M & 1 + \frac{1}{2}M & M & 0 & 2 - 5M \\ 0 & 2 & 1 & 1 & 0 & 0 & 2 \\ 0 & 0 & \frac{3}{2} & -\frac{1}{2} & -1 & 0 & 5 \\ 0 & 0 & \frac{1}{2} & -\frac{1}{2} & 0 & 1 & 3 \end{bmatrix} \begin{array}{l} \text{R1} + (1 + \frac{1}{2}M)\text{R2} \\ \text{R2} \\ \text{R3} - \frac{1}{2}\text{R2} \\ \text{R4} - \frac{1}{2}\text{R2} \end{array}$$

and from this

$$\mathbf{T}_2 = \begin{bmatrix} 1 & 3M & 0 & 1 + 2M & M & 0 & 2 - 2M \\ 0 & 2 & 1 & 1 & 0 & 0 & 2 \\ 0 & -3 & 0 & -2 & -1 & 0 & 2 \\ 0 & -1 & 0 & -1 & 0 & 1 & 2 \end{bmatrix} \begin{array}{l} \text{R1} + \frac{3}{2}M\text{R2} \\ \text{R2} \\ \text{R3} - \frac{3}{2}\text{R2} \\ \text{R4} - \frac{1}{2}\text{R2} \end{array}$$

which still contains  $M$ .

**SOLUTIONS TO CHAP. 22 REVIEW QUESTIONS AND PROBLEMS,  
page 952**

4. Replace  $-\nabla f$  by  $+\nabla f$ .
8.  $[6 \ 3]^T$ ,  $[0.9153 \ -0.8136]^T$ ,  $[0.2219 \ 0.1109]^T$ ,  $[0.0338 \ -0.0301]^T$ . Slimmer ellipses give slower convergence, as can be seen from Fig. 472 in Sec. 22.1.
10.  $f(\mathbf{x}) = x_1^2 + 1.5x_2^2$  implies

$$\mathbf{z}(t) = [(1 - 2t)x_1 \ (1 - 3t)x_2]^T,$$

$$g(t) = f(\mathbf{z}(t)) = (1 - 2t)^2 x_1^2 + 1.5(1 - 3t)^2 x_2^2$$

and by differentiation,

$$g'(t) = -4(1 - 2t)x_1^2 - 9(1 - 3t)x_2^2 = 0.$$

The solution is

$$t_1 = \frac{4x_1^2 + 9x_2^2}{8x_1^2 + 27x_2^2}$$

so that

$$1 - 2t_1 = \frac{9x_2^2}{8x_1^2 + 27x_2^2}, \quad 1 - 3t_1 = \frac{-4x_1^2}{8x_1^2 + 27x_2^2}.$$

For  $x_1 = 1.5$ ,  $x_2 = 1$  this gives

$$\mathbf{x}_1 = \mathbf{z}(t_1) = 0.2[1.5 \ -1]^T,$$

and, furthermore,  $\mathbf{x}_2 = 0.04[1.5 \ +1]^T$ , etc.

12. Nine steps give the solution  $[-1 \ 2]$  to 6S. Steps 1–5 give

| $x_1$     | $x_2$   |
|-----------|---------|
| -1.01462  | 3.77669 |
| -0.888521 | 2.07432 |
| -1.00054  | 2.06602 |
| -0.995857 | 2.00276 |
| -1.00002  | 2.00245 |

14. The values obtained are

| $x_1$     | $x_2$    |
|-----------|----------|
| -1.04366  | 0.231924 |
| -0.758212 | 1.51642  |
| -1.01056  | 1.57250  |
| -0.941538 | 1.88308  |
| -1.00255  | 1.89664  |

Gradients (times a scalar) are obtained by calculating differences of subsequent values. Orthogonality follows from the fact that we change direction when we are tangent to a level curve and then proceed perpendicular to it.

22. The augmented matrix of the given data is

$$\mathbf{T}_0 = \begin{bmatrix} 1 & -1 & -1 & 0 & 0 & 0 & 0 \\ 0 & 1 & 2 & 1 & 0 & 0 & 10 \\ 0 & 2 & 1 & 0 & 1 & 0 & 10 \\ 0 & 0 & 1 & 0 & 0 & 1 & 4 \end{bmatrix}.$$

The pivot is 2 in Row 3 and Column 2. The calculation gives

$$\mathbf{T}_1 = \begin{bmatrix} 1 & 0 & -\frac{1}{2} & 0 & \frac{1}{2} & 0 & 5 \\ 0 & 0 & \frac{3}{2} & 1 & -\frac{1}{2} & 0 & 5 \\ 0 & 2 & 1 & 0 & 1 & 0 & 10 \\ 0 & 0 & 1 & 0 & 0 & 1 & 4 \end{bmatrix} \begin{array}{l} \text{Row 1} + \frac{1}{2} \text{ Row 3} \\ \text{Row 2} - \frac{1}{2} \text{ Row 3} \\ \text{Row 3} \\ \text{Row 4.} \end{array}$$

The next pivot is  $\frac{3}{2}$  in Row 2. The calculation gives

$$\mathbf{T}_2 = \begin{bmatrix} 1 & 0 & 0 & \frac{1}{3} & \frac{1}{3} & 0 & \frac{20}{3} \\ 0 & 0 & \frac{3}{2} & 1 & -\frac{1}{2} & 0 & 5 \\ 0 & 2 & 0 & -\frac{2}{3} & \frac{4}{3} & 0 & \frac{20}{3} \\ 0 & 0 & 0 & -\frac{2}{3} & \frac{1}{3} & 1 & \frac{2}{3} \end{bmatrix} \begin{array}{l} \text{Row 1} + \frac{1}{3} \text{ Row 2} \\ \text{Row 2} \\ \text{Row 3} - \frac{2}{3} \text{ Row 2} \\ \text{Row 4} - \frac{2}{3} \text{ Row 2.} \end{array}$$

We see from the last matrix that for the maximum we have

$$f\left(\frac{20/3}{2}, \frac{5}{3/2}\right) = f\left(\frac{10}{3}, \frac{10}{3}\right) = \frac{20}{3}.$$

24. The matrix of the given data is

$$\mathbf{T}_0 = \begin{bmatrix} 1 & -60 & -30 & 0 & 0 & 0 \\ 0 & 40 & 40 & 1 & 0 & 1800 \\ 0 & 200 & 20 & 0 & 1 & 6300 \end{bmatrix}$$

The pivot is 200. The calculation gives

$$\mathbf{T}_1 = \begin{bmatrix} 1 & 0 & -24 & 0 & \frac{3}{10} & 1890 \\ 0 & 0 & 36 & 1 & -\frac{1}{5} & 540 \\ 0 & 200 & 20 & 0 & 1 & 6300 \end{bmatrix} \begin{array}{l} \text{Row 1} + \frac{60}{200} \text{ Row 3} \\ \text{Row 2} - \frac{1}{5} \text{ Row 3} \\ \text{Row 3} \end{array}$$

The next pivot is 36. The calculation gives

$$\mathbf{T}_2 = \begin{bmatrix} 1 & 0 & 0 & \frac{2}{3} & \frac{1}{6} & 2250 \\ 0 & 0 & 36 & 1 & -\frac{1}{5} & 540 \\ 0 & 200 & 0 & -\frac{5}{9} & \frac{10}{9} & 6000 \end{bmatrix} \begin{array}{l} \text{Row 1} + \frac{24}{36} \text{ Row 2} \\ \text{Row 2} \\ \text{Row 3} - \frac{20}{36} \text{ Row 2} \end{array}$$

Hence the solution is

$$f\left(\frac{6000}{200}, \frac{540}{36}\right) = f(30, 15) = 2250.$$

## CHAPTER 23 Graphs. Combinatorial Optimization

### SECTION 23.1. Graphs and Digraphs, page 954

**Purpose.** To explain the concepts of a graph and a digraph (directed graph) and related concepts, as well as their computer representations.

#### Main Content, Important Concepts

Graph, vertices, edges

Incidence of a vertex  $v$  with an edge, degree of  $v$

Digraph

Adjacency matrix

Incidence matrix

Vertex incidence list, edge incidence list

#### Comment on Content

Graphs and digraphs have become more and more important, due to an increase of supply and demand—a supply of more and more powerful methods of handling graphs and digraphs, and a demand for those methods in more and more problems and fields of application. Our chapter, devoted to the modern central area of combinatorial optimization, will give us a chance to get a feel for the usefulness of graphs and digraphs in general.

### SOLUTIONS TO PROBLEM SET 23.1, page 958

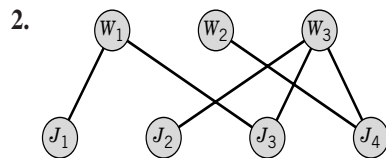

6. The adjacency matrix is

$$\begin{bmatrix} 0 & 1 & 1 & 1 \\ 1 & 0 & 1 & 1 \\ 1 & 1 & 0 & 0 \\ 1 & 1 & 0 & 0 \end{bmatrix}.$$

Adding the edge between 3 and 4, we would have a complete graph. The only zeros of the matrix outside the main diagonal correspond to that edge.

8.

$$\begin{bmatrix} 0 & 1 & 0 & 1 & 0 & 0 \\ 1 & 0 & 1 & 1 & 0 & 0 \\ 0 & 1 & 0 & 1 & 0 & 0 \\ 1 & 1 & 1 & 0 & 1 & 1 \\ 0 & 0 & 0 & 1 & 0 & 0 \\ 0 & 0 & 0 & 1 & 0 & 0 \end{bmatrix}$$

10. 
$$\begin{bmatrix} 0 & 0 & 0 & 1 & 0 & 0 \\ 0 & 0 & 0 & 0 & 1 & 1 \\ 0 & 0 & 0 & 0 & 0 & 0 \\ 1 & 0 & 0 & 0 & 1 & 0 \\ 1 & 1 & 0 & 0 & 0 & 0 \\ 0 & 0 & 1 & 0 & 1 & 0 \end{bmatrix}$$

12. 
$$\begin{bmatrix} 0 & 1 & 1 & 1 & 1 \\ 1 & 0 & 1 & 1 & 1 \\ 1 & 1 & 0 & 0 & 0 \\ 1 & 1 & 0 & 0 & 0 \\ 1 & 1 & 0 & 0 & 0 \end{bmatrix}$$

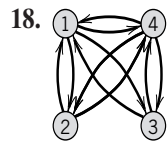
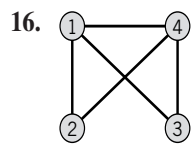
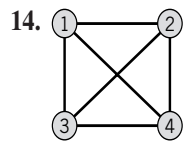

20. If and only if  $G$  is complete.

In this case the adjacency matrix of  $G$  has  $n^2 - n = n(n - 1)$  ones, and since every edge contributes two ones, the number of edges is  $n(n - 1)/2$ . This gives another proof of Prob. 19.

22. The matrix is

|        |   | Edge  |       |       |       |       |       |       |
|--------|---|-------|-------|-------|-------|-------|-------|-------|
|        |   | $e_1$ | $e_2$ | $e_3$ | $e_4$ | $e_5$ | $e_6$ | $e_7$ |
| Vertex | 1 | 1     | 0     | 1     | 0     | 0     | 0     | 0     |
|        | 2 | 1     | 1     | 0     | 1     | 0     | 0     | 0     |
|        | 3 | 0     | 1     | 0     | 0     | 1     | 0     | 0     |
|        | 4 | 0     | 0     | 1     | 1     | 1     | 1     | 1     |
|        | 5 | 0     | 0     | 0     | 0     | 0     | 1     | 0     |
|        | 6 | 0     | 0     | 0     | 0     | 0     | 0     | 1     |

24. The matrix is

|        |   | Edge  |       |       |       |
|--------|---|-------|-------|-------|-------|
|        |   | $e_1$ | $e_2$ | $e_3$ | $e_4$ |
| Vertex | 1 | -1    | -1    | 1     | -1    |
|        | 2 | 1     | 0     | 0     | 0     |
|        | 3 | 0     | 1     | -1    | 0     |
|        | 4 | 0     | 0     | 0     | 1     |

**SECTION 23.2. Shortest Path Problems. Complexity, page 959**

**Purpose.** To explain a method (by Moore) of determining a shortest path from a given vertex  $s$  to a given vertex  $t$  in a graph, all of whose edges have length 1.

**Main Content, Important Concepts**

- Moore's algorithm (Table 23.1)
- BFS (Breadth First Search), DFS (Depth First Search)
- Complexity of an algorithm
- Efficient, polynomially bounded

**Comment on Content**

The basic idea of Moore's algorithm is quite simple. A few related ideas and problems are illustrated in the problem set.

**SOLUTIONS TO PROBLEM SET 23.2, page 962**

2. There are three shortest paths, of length 4 each:

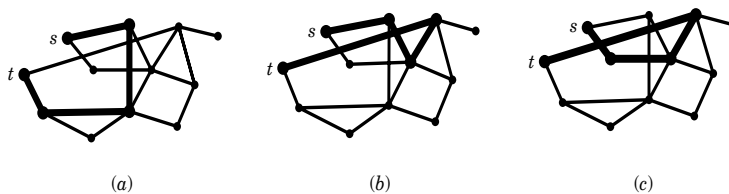

Which one we obtain in backtracking depends on the numbering (not labeling!) of the vertices and on the backtracking rule. For the rule in Example 1 and the numbering shown in the following figure we get (B).

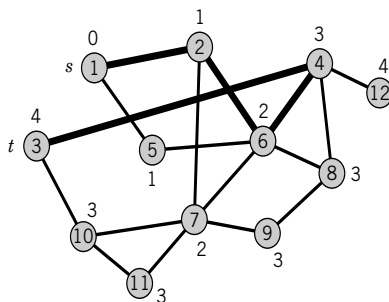

If we change the rule and let the computer look for largest (instead of smallest) numbers, we get (A).

4. The length of a shortest path is 5. No uniqueness.
6. The length of the unique shortest path is 4.
8.  $n - 1$ . If it had more, a vertex would appear more than once and the corresponding cycle could be omitted. One edge.
10. This is true for  $l = 0$  since then  $v = s$ . Let it be true for an  $l - 1$ . Then  $\lambda(v_{l-1}) = l - 1$  for the predecessor  $v_{l-1}$  of  $v$  on a shortest path  $s \rightarrow v$ . We claim that when  $v_{l-1}$  gets labeled,  $v$  is still unlabeled (so that we shall have  $\lambda(v) = l$  as wanted). Indeed, if  $v$  were labeled, it would have a label less than  $l$ , hence distance less than  $l$  by Prob. 9, contradicting that  $v$  has distance  $l$ .

12.

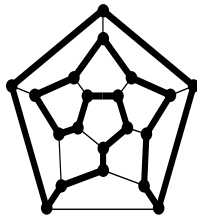

14. Delete the edge  $(2, 4)$ .
16.  $1 - 2 - 3 - 4 - 5 - 3 - 1$ ,  $1 - 3 - 4 - 5 - 3 - 2 - 1$ , and these two trails traversed in the opposite sense
18. Let  $T: s \rightarrow s$  be a shortest postman trail and  $v$  any vertex. Since  $T$  includes each edge,  $T$  visits  $v$ . Let  $T_1: s \rightarrow v$  be the portion of  $T$  from  $s$  to the first visit of  $v$  and  $T_2: v \rightarrow s$  the other portion of  $T$ . Then the trail  $v \rightarrow v$  consisting of  $T_2$  followed by  $T_1$  has the same length as  $T$  and solves the postman problem.

### SECTION 23.3. Bellman's Principle. Dijkstra's Algorithm, page 963

**Purpose.** This section extends the previous one to graphs whose edges have any (positive) length and explains a popular corresponding algorithm (by Dijkstra).

#### Main Content, Important Concepts

Bellman's optimality principle, Bellman's equations

Dijkstra's algorithm (Table 23.2)

#### Comment on Content

Throughout this chapter, one should emphasize that algorithms are needed because most practical problems are so large that solution by inspection would fail, even if one were satisfied with approximately optimal solutions.

### SOLUTIONS TO PROBLEM SET 23.3, page 966

2. Dijkstra's algorithm gives
  1.  $L_1 = 0, \tilde{L}_2 = 4, \tilde{L}_3 = 12, \tilde{L}_4 = 16, \tilde{L}_5 = \infty$
  2.  $L_2 = 4, k = 2$
  3.  $\tilde{L}_3 = \min \{12, 4 + l_{23}\} = 10$   
 $\tilde{L}_4 = \min \{16, 4 + l_{24}\} = 16$   
 $\tilde{L}_5 = \min \{\infty, 4 + \infty\} = \infty$
  2.  $L_3 = 10, k = 3$
  3.  $\tilde{L}_4 = \min \{16, 10 + l_{34}\} = 16$   
 $\tilde{L}_5 = \min \{\infty, 10 + \infty\} = \infty$

2.  $L_4 = 16, k = 4$
3.  $\tilde{L}_5 = \min \{\infty, 16 + l_{45}\} = 56$
2.  $L_5 = 56, k = 5,$

so that the *answer* is

$$(1, 2), (1, 4), (2, 3), (4, 5); \quad L_2 = 4, L_3 = 10, L_4 = 16, L_5 = 56.$$

4. Dijkstra's algorithm gives

1.  $L_1 = 0, \tilde{L}_2 = 8, \tilde{L}_3 = 10, \tilde{L}_4 = \infty, \tilde{L}_5 = 5, \tilde{L}_6 = \infty$
2.  $L_5 = 5$
3.  $\tilde{L}_2 = \min \{8, 5 + l_{52}\} = 7$   
 $\tilde{L}_3 = \min \{10, 5 + l_{53}\} = 10$   
 $\tilde{L}_4 = \min \{\infty, 5 + l_{54}\} = 10$   
 $\tilde{L}_6 = \min \{\infty, 5 + l_{56}\} = 7$
2.  $L_2 = 7$
3.  $\tilde{L}_3 = \min \{10, 7 + l_{23}\} = 9$   
 $\tilde{L}_4 = \min \{10, 7 + l_{24}\} = 10$   
 $\tilde{L}_6 = \min \{7, 7 + l_{26}\} = 7$
2.  $L_6 = 7$
3.  $\tilde{L}_3 = \min \{9, 7 + l_{63}\} = \min \{9, 7 + \infty\} = 9$   
 $\tilde{L}_4 = \min \{10, 7 + l_{64}\} = 8$
2.  $L_4 = 8$
3.  $\tilde{L}_3 = \min \{9, 8 + l_{43}\} = \min \{9, 8 + \infty\} = 9$
2.  $L_3 = 9.$

The *answer* is (1, 5), (2, 3), (2, 5), (4, 6), (5, 6);  $L_2 = 7, L_3 = 9, L_4 = 8,$   
 $L_5 = 5, L_6 = 7.$

6. Dijkstra's algorithm gives

1.  $L_1 = 0, \tilde{L}_2 = 15, \tilde{L}_3 = 2, \tilde{L}_4 = 10, \tilde{L}_5 = 6$
2.  $L_3 = 2$
3.  $\tilde{L}_2 = \min \{15, 2 + l_{32}\} = 15$   
 $\tilde{L}_4 = \min \{10, 2 + l_{34}\} = 10$   
 $\tilde{L}_5 = \min \{6, 2 + l_{35}\} = 5$
2.  $L_5 = 5$
3.  $\tilde{L}_2 = \min \{15, 5 + l_{52}\} = \min \{15, 5 + \infty\} = 15$   
 $\tilde{L}_4 = \min \{10, 5 + l_{54}\} = 9$
2.  $L_4 = 9$
3.  $\tilde{L}_2 = \min \{15, 9 + l_{42}\} = 14$
2.  $L_2 = 14.$

The *answer* is (1, 3), (2, 4), (3, 5), (4, 5);  $L_2 = 14, L_3 = 2, L_4 = 9,$   
 $L_5 = 5.$

8. Let  $j$  be the vertex that gave  $k$  its present label  $L_k$ , namely,  $L_j + l_{jk}$ . After this label was assigned,  $j$  did not change its label, since it was then removed from  $\mathcal{T}\mathcal{L}$ . Next, find the vertex which gave  $j$  its permanent label, etc. This backward search traces a path from 1 to  $k$ , whose length is exactly  $L_k$ .



**SECTION 23.4. Shortest Spanning Trees: Greedy Algorithm, page 966**

**Purpose.** After the discussion of shortest paths between two given vertices, this section is devoted to the construction of a tree in a given graph that is spanning (contains all vertices of the graph) and is of minimum length.

**Main Content, Important Concepts**

Tree

Cycle

Kruskal's greedy algorithm (Table 23.3)

**Comment on Content**

Figure 490 illustrates that Kruskal's algorithm does not necessarily give a tree during each intermediate step, in contrast to another algorithm to be discussed in the next section.

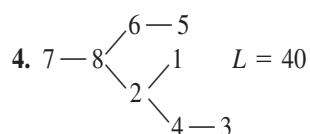
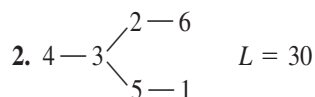
**SOLUTIONS TO PROBLEM SET 23.4, page 969**

Note that trees, just as general graphs, can be sketched in different ways.

6. We obtain the edges in the order (1, 6), (2, 6), (3, 5), (3, 6), (2, 4) and can sketch the tree, for instance, in the form

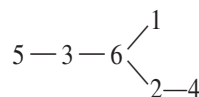

Its length is  $L = 17$ .

8. Order the edges in descending order of length and choose them in this order, rejecting when a cycle would arise.
10. Order the edges in descending order of length and delete them in this order, retaining an edge only if it would lead to the omission of a vertex or to a disconnected graph.
12. New York – Washington – Chicago – Dallas – Denver – Los Angeles
14. Let  $P_1: u \rightarrow v$  and  $P_2: u \rightarrow v$  be different. Let  $e = (w, x)$  be in  $P_1$  but not in  $P_2$ . Then  $P_1$  without  $e$  together with  $P_2$  is a connected graph. Hence it contains a path  $P_3: w \rightarrow x$ . Hence  $P_3$  together with  $e$  is a cycle in  $T$ , a contradiction.
16. Extend an edge  $e$  into a path by adding edges to its ends if such edges exist. A new edge attached at the end of the path introduces a new vertex, or closes a cycle, which contradicts our assumption. This extension terminates on both sides of  $e$ , yielding two vertices of degree 1.
18. True for  $n = 2$ . Assume truth for all trees with less than  $n$  vertices. Let  $T$  be a tree with  $n \geq 2$  vertices, and  $(u, v)$  an edge of  $T$ . Then  $T$  without  $(u, v)$  contains no path  $u \rightarrow v$ , by Prob. 14. Hence this graph is disconnected. Let  $G_1, G_2$  be its connected components, having  $n_1$  and  $n_2$  vertices, hence  $n_1 - 1$  and  $n_2 - 1$  edges, respectively, by the induction hypothesis, so that  $G$  has  $n_1 - 1 + n_2 - 1 + 1 = n - 1$  edges.



We see that we got

$$(1, 2), (2, 3), (3, 6), (4, 6), (3, 5), (3, 7), (2, 8).$$

The length is  $L = 28$ .

6. The algorithm gives

| Vertex | Initial Label | Relabeling    |               |              |
|--------|---------------|---------------|---------------|--------------|
|        |               | (I)           | (II)          | (III)        |
| 2      | $l_{12} = 6$  | $l_{32} = 3$  |               |              |
| 3      | $l_{13} = 1$  |               |               |              |
| 4      | $\infty$      | $l_{34} = 10$ | $l_{34} = 10$ | $l_{34} = 2$ |
| 5      | $l_{15} = 15$ | $l_{15} = 15$ | $l_{25} = 9$  |              |

We see that we got

$$(1, 3), (2, 3), (2, 5), (4, 5).$$

The tree has the length  $L = 15$ .

8. In Step 2 we first select a smallest  $l_{1j}$  for the  $n - 1$  vertices outside  $U$ ; these are  $n - 2$  comparisons. Step 3 then requires  $n - 2$  updating (pairwise comparisons). In the next round we have  $n - 3$  comparisons in Step 2 and  $n - 3$  updating in Step 3, and so on, until we finally end up with 1 comparison and 1 updating. The sum of all these numbers is  $(n - 2)(n - 1) = O(n^2)$ .
10. An algorithm for minimum spanning trees must examine each entry of the distance matrix at least once, because an entry not looked upon might have been one that should have been included in a shortest spanning tree. Hence, examining the relevant given information is already  $O(n^2)$  work.
12. **Team Project.** (a)  $\epsilon(1) = 16$ ,  $\epsilon(2) = 22$ ,  $\epsilon(3) = 12$ .  
 (b)  $d(G) = 24$ ,  $r(G) = 12 = \epsilon(3)$ , center  $\{3\}$ .  
 (c) 20, 14, center  $\{3, 4\}$   
 (e) Let  $T^*$  be obtained from  $T$  by deleting all endpoints (= vertices of degree 1) together with the edges to which they belong. Since for fixed  $u$ ,  $\max d(u, v)$  occurs only when  $v$  is an endpoint,  $\epsilon(u)$  is one less in  $T^*$  than it is in  $T$ . Hence the vertices of minimum eccentricity in  $T$  are the same as those in  $T^*$ . Thus  $T$  has the same center as  $T^*$ . Delete the endpoints of  $T^*$  to get a tree  $T^{**}$  whose center is the same as that of  $T$ , etc. The process terminates when only one vertex or two adjacent vertices are left.  
 (f) Choose a vertex  $u$  and find a farthest  $v_1$ . From  $v_1$  find a farthest  $v_2$ . Find  $w$  such that  $d(w, v_1)$  is as close as possible to being equal to  $\frac{1}{2}d(v_1, v_2)$ .

### SECTION 23.6. Flows in Networks, page 973

**Purpose.** After shortest paths and spanning trees we discuss in this section a third class of practically important problems, the optimization of flows in networks.

#### Main Content, Important Concepts

Network, source, target (sink)

Edge condition, vertex condition

Path in a digraph, forward edge, backward edge

Flow augmenting path

Cut set, Theorems 1 and 2

Augmenting path theorem for flows (Theorem 3)

Max-flow min-cut theorem

### Comment on Content

An algorithm for determining flow augmenting paths follows in the next section.

## SOLUTIONS TO PROBLEM SET 23.6, page 978

2. Flow augmenting paths are

$$P_1: 1 - 2 - 4 - 6, \Delta f = 1$$

$$P_2: 1 - 3 - 5 - 6, \Delta f = 1$$

$$P_3: 1 - 2 - 3 - 5 - 6, \Delta f = 1$$

$$P_4: 1 - 2 - 3 - 4 - 5 - 6, \Delta f = 1, \text{ etc.}$$

4. Flow augmenting paths are

$$P_1: 1 - 2 - 4 - 5, \Delta f = 2$$

$$P_2: 1 - 2 - 5, \Delta f = 2$$

$$P_3: 1 - 2 - 3 - 5, \Delta f = 3$$

$$P_4: 1 - 3 - 5, \Delta f = 5, \text{ etc.}$$

6. The maximum flow is  $f = 4$ . It can be realized by

$$f_{12} = 2, f_{13} = 2, f_{24} = 1, f_{23} = 1, f_{35} = 1, f_{34} = 2, f_{45} = 0, f_{46} = 3, f_{56} = 1.$$

$f$  is unique, but the way in which it is achieved is not, in general. In the present case we can change  $f_{45}$  from 0 to 1,  $f_{46}$  from 3 to 2,  $f_{56}$  from 1 to 2.

8. The maximum flow is  $f = 17$ . It can be achieved by

$$f_{12} = 8, f_{13} = 9, f_{23} = 0, f_{24} = 4, f_{25} = 4, f_{35} = 10, f_{43} = 1, f_{45} = 3.$$

10.  $\{3, 6\}$ , 14

12. The cut set in Prob. 10

14.  $\{3, 5, 6, 7\}$ , 14

16.  $\{6, 7\}$ , 14

18. One is interested in flows from  $s$  to  $t$ , not in the opposite direction.

## SECTION 23.7. Maximum Flow: Ford–Fulkerson Algorithm, page 979

**Purpose.** To discuss an algorithm (by Ford and Fulkerson) for systematically increasing a flow in a network (e.g., the zero flow) by constructing flow augmenting paths until the maximum flow is reached.

### Main Content, Important Concepts

Forward edge, backward edge

Ford–Fulkerson algorithm (Table 23.8)

Scanning of a labeled vertex

**Comment on Content**

Note that this is the first section in which we are dealing with digraphs.

**SOLUTIONS TO PROBLEM SET 23.7, page 982**

2. Not more work than in Example 1. Steps 1–7 are similar to those in the example and give the flow augmenting path

$$P_1: \quad 1 - 2 - 3 - 6,$$

which augments the flow from 0 to 11.

In determining a second flow augmenting path we scan 1, labeling 2 and 4 and getting  $\Delta_2 = 9$ ,  $\Delta_4 = 10$ . In scanning 2, that is, trying to label 3 and 5, we cannot label 3 because  $c_{ij} = c_{23} = f_{ij} = f_{23} = 11$ , and we cannot label 5 because  $f_{52} = 0$ . In scanning 4 (i.e., labeling 5) we get  $\Delta_5 = 7$ . In scanning 5 we cannot label 3 because  $f_{35} = 0$ , and we further get  $\Delta_6 = 3$ . Hence a flow augmenting path is

$$P_2: \quad 1 - 4 - 5 - 6$$

and  $\Delta_t = 3$ . Together we get the maximum flow  $11 + 3 = 14$  because no further flow augmenting paths can be found. The result agrees with that in Example 1.

4. Scanning the vertices in the order of their numbers, we get a flow augmenting path

$$P_1: \quad 1 - 2 - 4 - 6$$

with  $\Delta_t = 1$  and then

$$P_2: \quad 1 - 3 - 4 - 6$$

with  $\Delta_t = 1$ , but no further flow augmenting path. Since the initial flow was 2, this gives the total flow  $f = 4$ .

6. The given flow equals 9. We first get the flow augmenting path

$$P_1: \quad 1 - 2 - 5 \quad \text{with} \quad \Delta_t = 2,$$

then the flow augmenting path

$$P_2: \quad 1 - 3 - 5 \quad \text{with} \quad \Delta_t = 5,$$

and finally the flow augmenting path

$$P_3: \quad 1 - 2 - 3 - 5 \quad \text{with} \quad \Delta_t = 1.$$

The maximum flow is  $9 + 2 + 5 + 1 = 17$ .

8. At each vertex, the inflow and the outflow are increased by the same amount.
12. Start from the zero flow. If it is not maximum, there is an augmenting path by which we can augment the flow by an amount that is an integer, since the capacities are integers, etc.
14. The forward edges of the set are used to capacity; otherwise one would have been able to label their other ends. Similarly for the backward edges of the set, which carry no flow.
16.  $f = 7$
18. Let  $G$  have  $k$  edge-disjoint paths  $s \rightarrow t$ , and let  $\tilde{f}$  be a maximum flow in  $G$ . Define on those paths a flow  $f$  by  $f(e) = 1$  on each of their edges. Then  $f = k \leq \tilde{f}$  since  $\tilde{f}$  is maximum. Now let  $G^*$  be obtained from  $G$  by deleting edges that carry no portion of  $\tilde{f}$ . Then, since each edge has capacity 1, there exist  $\tilde{f}$  edge-disjoint paths in  $G^*$ , hence also in  $G$ , and  $\tilde{f} \leq k$ . Together,  $\tilde{f} = k$ .

20. Since  $(S, T)$  is a cut set, there is no directed path  $s \rightarrow t$  in  $G$  with the edges of  $(S, T)$  deleted. Since all edges have capacity 1, we thus obtain

$$\text{cap}(S, T) \cong q.$$

Now let  $E_0$  be a set of  $q$  edges whose deletion destroys all directed paths  $s \rightarrow t$ , and let  $G_0$  denote  $G$  without these  $q$  edges. Let  $V_0$  be the set of all those vertices  $v$  in  $G_0$  for which there is a directed path  $s \rightarrow v$ . Let  $V_1$  be the set of the other vertices in  $G$ . Then  $(V_0, V_1)$  is a cut set since  $s \in V_0$  and  $t \in V_1$ . This cut set contains none of the edges of  $G_0$ , by the definition of  $V_0$ . Hence all the edges of  $(V_0, V_1)$  are in  $E_0$ , which has  $q$  edges. Now  $(S, T)$  is a *minimum* cut set, and all the edges have capacity 1. Thus,

$$\text{cap}(S, T) \leq \text{cap}(V_0, V_1) \leq q.$$

Together,  $\text{cap}(S, T) = q$ .

### SECTION 23.8. Bipartite Graphs. Assignment Problems, page 982

**Purpose.** As the last class of problems, in this section we explain assignment problems (of workers to jobs, goods to storage spaces, etc.), so that the vertex set  $V$  of the graph consists of two subsets  $S$  and  $T$  and vertices in  $S$  are assigned (related by edges) to vertices in  $T$ .

#### Main Content, Important Concepts

Bipartite graph  $G = (V, E) = (S, T; E)$

Matching, maximum cardinality matching

Exposed vertex

Alternating path, augmenting path

Matching algorithm (Table 23.9)

#### Comment on Content

A few additional problems on graphs, related to the present circle of ideas as well as of a more general nature, are contained in the problem set.

### SOLUTIONS TO PROBLEM SET 23.8, page 986

2. Yes,  $S = \{1, 4\}$ ,  $T = \{2, 3\}$   
 4. Yes,  $S = \{1, 3, 5\}$ ,  $T = \{2, 4, 6\}$   
 6. Yes,  $S = \{1, 3, 4\}$ ,  $T = \{2, 5\}$   
 8.  $7 - 8 - 3 - 4 - 5 - 6 - 1 - 2$   
 10.  $1 - 2 - 3 - 7 - 5 - 4$   
 12.  $(1, 2)$ ,  $(3, 4)$ ,  $(5, 6)$ ,  $(7, 8)$ , by inspection or by the use of the path in the answer to Prob 8.  
 14.

|       | Period |       |       |       |
|-------|--------|-------|-------|-------|
|       | 1      | 2     | 3     | 4     |
| $x_1$ | $y_4$  | $y_3$ | $y_1$ | —     |
| $x_2$ | $y_1$  | $y_4$ | $y_3$ | $y_2$ |
| $x_3$ | —      | $y_2$ | $y_4$ | $y_3$ |

16. 2

18. 4

20.  $n_1 n_2$ 

22. One might perhaps mention that the particular significance of  $K_5$  and  $K_{3,3}$  results from **Kuratowski's theorem**, stating that a graph is planar if and only if it contains no subdivision of  $K_5$  or  $K_{3,3}$  (that is, it contains no subgraph obtained from  $K_5$  or  $K_{3,3}$  by subdividing the edges of these graphs by introducing new vertices on them).

24.  $\max d(u) = n$ . Let  $u_1, \dots, u_n$  and  $v_1, \dots, v_n$  denote the vertices of  $S$  and  $T$ , respectively. Color edges  $(u_1, v_1), \dots, (u_1, v_n)$  by colors  $1, \dots, n$ , respectively, then edges  $(u_2, v_1), \dots, (u_2, v_n)$  by colors  $2, \dots, n, 1$ , respectively, etc., cyclicly permuted.

### SOLUTIONS TO CHAP. 23 REVIEW QUESTIONS AND PROBLEMS, page 987

$$12. \begin{bmatrix} 0 & 1 & 1 & 1 \\ 1 & 0 & 1 & 1 \\ 1 & 1 & 0 & 1 \\ 1 & 1 & 1 & 0 \end{bmatrix}$$

$$14. \begin{bmatrix} 0 & 1 & 1 \\ 1 & 0 & 0 \\ 1 & 1 & 0 \end{bmatrix}$$

$$16. \begin{bmatrix} 0 & 1 & 0 & 0 & 0 \\ 0 & 0 & 1 & 1 & 1 \\ 0 & 0 & 0 & 0 & 0 \\ 0 & 1 & 0 & 0 & 1 \\ 0 & 1 & 0 & 1 & 0 \end{bmatrix}$$

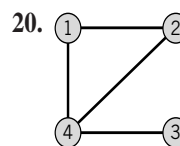
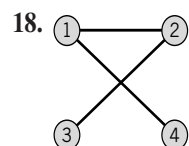

22.

| Vertex | Incident Edges         |
|--------|------------------------|
| 1      | $-e_1, e_2, e_4, -e_5$ |
| 2      | $e_3, -e_4, e_5$       |
| 3      | $e_1, -e_2, -e_3$      |

24.  $L = 5$ 26.  $L_2 = 16, L_3 = 6, L_4 = 2$ 28.  $L_2 = 2, L_3 = 4, L_4 = 3, L_5 = 6$ 30.  $1 - 2 - 4 - 3, L = 15$ 34.  $f = 9$ 36.  $(1, 6), (2, 4), (3, 5)$

# Part G. PROBABILITY, STATISTICS

## CHAPTER 24 Data Analysis. Probability Theory

### SECTION 24.1. Data Representation. Average. Spread, page 993

**Purpose.** To discuss standard graphical representations of data in statistics. To introduce concepts that characterize the average size of the data values and their spread (their variability).

#### Main Content, Important Concepts

Stem-and-leaf plot  
 Histogram  
 Boxplot  
 Absolute frequency, relative frequency  
 Cumulative relative frequency  
 Outliers  
 Mean  
 Variance, standard deviation  
 Median, quartiles, interquartile range

#### Comment on Content

The graphical representations of data to be discussed in this section have become standard in connection with statistical methods. Average size and variability give the two most important general characterizations of data. Relative frequency will motivate probability as its theoretical counterpart. This is a main reason for presenting this material here before the beginning of our discussion of probability in this chapter. Randomness is not mentioned in this section because the introduction of samples (random samples) as a concept can wait until Chap. 25 when we shall need them in connection with statistical methods. The connection with this section will then be immediate and will provide no difficulty or duplication.

### SOLUTIONS TO PROBLEM SET 24.1, page 996

2.  $q_L = 2, q_M = 5, q_U = 6$
4.  $q_L = 10.0, q_M = 11.6, q_U = 12.4$
6.  $q_L = -0.52, q_M = -0.19, q_U = 0.24$
8.  $q_L = 85, q_M = 87, q_U = 89$
10.  $q_L = q_M = 14, q_U = 14.5$
12.  $\bar{x} = 4.3, s = 2.541, \text{IQR} = 4$
14.  $\bar{x} = -0.064, s = 0.542, \text{IQR} = 0.76$
16.  $\bar{x} = 12.6$  but  $q_M = 7$ . The data are not sufficiently symmetric.  $s = 9.07, \text{IQR} = 17$
18.  $x_{\min} \leq x_j \leq x_{\max}$ . Now sum over  $j$  from 1 to  $n$ . Then divide by  $n$  to get  $x_{\min} \leq \bar{x} \leq x_{\max}$ .
20. Points to consider are the amounts of calculation, the size of the data (in using quartiles we lose information—the larger the number of data points, the more more information we lose), and the symmetry and asymmetry of the data. In the case of symmetry we



have better agreement between quartiles on the one hand and mean and variance on the other, as in the case of data with considerable deviation from symmetry.

### SECTION 24.2. Experiments, Outcomes, Events, page 997

**Purpose.** To introduce basic concepts needed throughout Chaps. 24 and 25.

#### Main Content, Important Concepts

Experiment  
 Sample space  $S$ , outcomes, events  
 Union, intersection, complements of events  
 Mutually exclusive events  
 Representation of sets by Venn diagrams

#### Comment on Content

To make the chapter self-contained, we explain the modest amount of set-theoretical concepts needed in the next sections, although most students will be familiar with these matters.

### SOLUTIONS TO PROBLEM SET 24.2, page 999

2.  $2^4 = 16$  outcomes ( $R = \text{Right-handed screw}$ ,  $L = \text{Left-handed screw}$ )

$RRRR$   
 $RRRL$      $RRLR$      $RLRR$      $LRRR$   
 $RRLL$      $RLRL$      $LRRL$      $RLLR$      $LRLR$      $LLRR$   
 $RLLL$      $LRLR$      $LLRL$      $LLL$   
 $LLL$

4. This is an example of a “waiting time problem”: We wait for the first *Head*. The sample space is infinite, the outcomes are ( $H = \text{Head}$ ,  $T = \text{Tail}$ )

$H$      $TH$      $TTH$      $TTTH$      $TTTTH$      $\dots$

6. 20 outcomes

$D$      $ND$      $NND$      $\dots$      $NNNNNNNNNNNNNNNNNNND$

$N = \text{drawing any other bolt}$

8. 10 outcomes, by choosing persons

123  
 124  
 125  
 134  
 135  
 145  
 234  
 235  
 245  
 345.

Section 24.4 will help us to get the answer without listing cases.

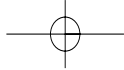

10. We obtain

$$A = \{(1, 1), (2, 2), (3, 3), (4, 4), (5, 5), (6, 6)\}$$

$$B = \{(4, 6), (5, 5), (6, 4), (5, 6), (6, 5), (6, 6)\}$$

$$C = \{(1, 6), (2, 5), (3, 4), (4, 3), (5, 2), (6, 1)\}.$$

12.  $(5, 5, 5) \in A \cap B$ , hence the answer is no. Note that

$$A \cap B = \{(3, 6, 6), (4, 5, 6), (4, 6, 5), (5, 4, 6), (5, 5, 5), (5, 6, 4), (6, 3, 6), (6, 4, 5), (6, 5, 4), (6, 6, 3)\}.$$

14. The subsets are

$$\emptyset, \{a\}, \{b\}, \{c\}, \{a, b\}, \{a, c\}, \{b, c\}, S.$$

16. For instance, for the first formula we can proceed as follows (see the figure). On the right,

$$A \cup B: \text{All except } 3$$

$$A \cup C: \text{All except } 5$$

and the intersection of these two is

$$\text{Right side: All except } 3 \text{ and } 5.$$

On the left,

$$A = 1 \cup 2 \cup 6 \cup 7$$

$$B \cap C = 4 \cup 7$$

and the union of these two gives the same as on the right.

Similarly for the other formula.

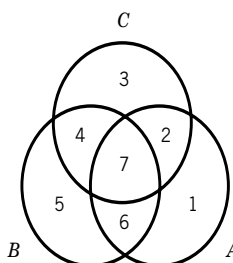

Section 24.2. Problem 16

18. Obviously,  $A \subseteq B$  implies  $A \cap B = A$ . Conversely, if  $A \cap B = A$ , then every element of  $A$  must also be in  $B$ , by the definition of intersection; hence  $A \subseteq B$ .

20.  $A \cup B = B$  implies  $A \subseteq B$  by the definition of union. Conversely,  $A \subseteq B$  implies that  $A \cup B = B$  because always  $B \subseteq A \cup B$ , and if  $A \subseteq B$ , we must have equality in the previous relation.

### SECTION 24.3. Probability, page 1000

**Purpose.** To introduce

1. Laplace's elementary probability concept based on *equally likely* outcomes,
2. The general probability concept defined axiomatically.



**Main Content, Important Concepts**

Definition 1 of probability  
 Definition 2 of probability  
 Motivation of the axioms of probability by relative frequency  
 Complementation rule, addition rules  
 Conditional probability  
 Multiplication rule, independent events  
 Sampling with and without replacement

**Comments on Content**

Whereas Laplace's definition of probability takes care of some applications and some statistical methods (for instance, nonparametric methods in Sec. 25.8), the major part of applications and theory will be based on the axiomatic definition of probability, which should thus receive the main emphasis in this section.

Sampling with and without replacement will be discussed in detail in Sec. 24.7.

**SOLUTIONS TO PROBLEM SET 24.3, page 1005**

2. (a) (i)  $0.1 \cdot 0.9^2 \cdot 3 + 0.1^2 \cdot 0.9 \cdot 3 + 0.1^3 = 27.1\%$ , as can be seen by noting that

$$E = \{DNN, NDN, NND, DDN, DND, NDD, DDD\}.$$

- (ii) The complement of the answer in Prob.1 is  $1 - 0.729 = 27.1\%$ .

(b) (i)  $\frac{10}{100} \cdot \frac{90}{99} \cdot \frac{89}{98} \cdot 3 + \frac{10}{100} \cdot \frac{9}{99} \cdot \frac{90}{98} \cdot 3 + \frac{10}{100} \cdot \frac{9}{99} \cdot \frac{8}{98} = 27.35\%$

- (ii)  $1 - 0.7265 = 27.35\%$

4. If the sample is small compared to the size of the population from which we sample (this condition is rather obvious) and if the population contains *many* items in each class we are interested in (e.g., many defective as well as many nondefective items, etc.).

6. Increase from  $\frac{24}{25} = 0.96$  to  $\frac{20}{25} \cdot \frac{19}{24} + \frac{20}{25} \cdot \frac{5}{24} + \frac{5}{25} \cdot \frac{20}{24} = 0.96667$ , as can be seen from

$$E = \{RR, RL, LR\}.$$

8. We list the outcomes that favor the event whose probability we want to determine, and after each outcome the corresponding probability ( $F$  = female,  $M$  = male):

|        |        |
|--------|--------|
| $FF$   | $1/4$  |
| $MFF$  | $1/8$  |
| $FMF$  | $1/8$  |
| $MMFF$ | $1/16$ |
| $MFMF$ | $1/16$ |
| $FMMF$ | $1/16$ |

This gives the answer  $11/16$ .

Note that the result does not depend on the number  $n$  ( $\geq 6$ ) of cards, but only on the ratio  $F/M$ .

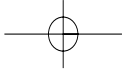

10.  $15/36$ . This is obtained by noting that

Sum 5 has 4 outcomes (1, 4), (2, 3), (3, 2), (4, 1),

Sum 6 has 5 outcomes, and Sum 7 has 6 outcomes.

12. The event “*odd product*” consists of 9 outcomes

(1, 1), (1, 3), (1, 5)

(3, 1), (3, 3), (3, 5)

(5, 1), (5, 3), (5, 5).

Three of them consist of equal numbers, so that the complement of the event in Prob. 11 consists of  $9 - 3 = 6$  outcomes, and  $1 - 6/36 = 30/36$ , in agreement with Prob. 11.

14.  $P^3 = 0.95$  gives  $P = 0.983$  as the probability that a single switch does not fail during a given time interval, and the answer is the complement of this, namely, 1.7%.
16. By the complementation rule,

$$P = 1 - 0.95^4 = 18.5\%.$$

18. We have

$$A = B \cup (A \cap B^c)$$

where  $B$  and  $A \cap B^c$  are disjoint because  $B$  and  $B^c$  are disjoint. Hence by Axiom 3,

$$P(A) = P(B) + P(A \cap B^c) \geq P(B)$$

because  $P(A \cap B^c)$  is a probability, hence nonnegative.

20. We have

$$P(A) = 2/4 = 1/2, \quad P(B) = 1/2, \quad P(C) = 1/2$$

and

$$P(A \cap B) = 1/4, \quad P(B \cap C) = 1/4, \quad P(C \cap A) = 1/4,$$

but  $P(A \cap B \cap C) = 0$  because there is no chip numbered 111; hence

$$P(A \cap B \cap C) \neq P(A)P(B)P(C) = 1/8.$$

#### SECTION 24.4. Permutations and Combinations, page 1006

**Purpose.** To discuss permutations and combinations as tools necessary for systematic counting in experiments with a large number of outcomes.

##### Main Content

Theorems 1–3 contain the main properties of permutations and combinations we must know.

Formulas (5)–(14) contain the main properties of factorials and binomial coefficients we need in practice.

##### Comment on Content

The student should become aware of the surprisingly large size of the numbers involved in (1)–(4), even for relatively modest numbers  $n$  of given elements, a fact that would make attempts to list cases a very impractical matter.



**SOLUTIONS TO PROBLEM SET 24.4, page 1010**

2. The  $5!/3! = 120/6 = 20$  permutations are

$\cdot$     *ae*   *ai*   *ao*   *au*  
*ea*    $\cdot$     *ei*   *eo*   *eu*  
*ia*   *ie*    $\cdot$     *io*   *iu*  
*oa*   *oe*   *oi*    $\cdot$     *ou*  
*ua*   *ue*   *ui*   *uo*    $\cdot$

The  $\binom{5}{2} = 10$  combination without repetition are obtained from the previous list by regarding the two pairs consisting of the same two letters (in opposite orders) as equal.

The  $\binom{5+2-1}{2} = \binom{6}{2} = 15$  combinations with repetitions consist of the 10 combinations just mentioned plus the 5 combinations

*aa ee ii oo uu.*

4.  $\binom{80}{4} = 1581580$

6.  $\binom{10}{3} \binom{5}{2} \binom{6}{2} = 18000$

8. There are  $\binom{100}{12}$  samples of 12 from 100; hence the probability of picking a particular

one is  $1 / \binom{100}{12}$ . Now the number of samples containing the two male mice is  $\binom{98}{10}$  because these are obtained by picking the two male mice and then 10 female mice from 98, which can be done in  $\binom{98}{10}$  ways. Hence the answer is

$$\binom{98}{10} / \binom{100}{12} = \frac{1}{75} = 1.3\%.$$

10. By a factor 7293 because

$$\frac{4!6!8!}{18!} / \frac{2!3!4!}{9!} = \frac{1}{17 \cdot 13 \cdot 11 \cdot 3} = \frac{1}{7293}.$$

12. In  $5!/5 = 4! = 24$  ways, where the denominator  $n = 5$  gives the number of cyclic permutations that give the same order on a round table.

14. The complementary event (no two people have a common birthday) has probability

$$\frac{1}{365^{20}} 365 \cdot 364 \cdots 346 = 0.5886$$

(which can also be nicely computed by the Stirling formula). This gives the answer 41%, which is surprisingly large.

16. 9 possible choices for the first unknown digit (0 to 9, not 5) and then 8 for the second.  
*Answer: 72.*

**18. Team Project.** (a) There are  $n$  choices for the first thing and we terminate with the  $k$ th thing, for which we have  $n - k + 1$  choices.

(b) The theorem holds when  $k = 1$ . Assuming that it holds for any fixed positive  $k$ , we show that the number of combinations of  $(k + 1)$ th order is  $\binom{n+k}{k+1}$ . From

the assumption it follows that there are  $\binom{n+k-1}{k}$  combinations of  $(k + 1)$ th order of  $n$  elements whose first element is 1 (this is the number of combinations of  $k$ th order of  $n$  elements *with repetitions*). Then there are  $\binom{n+k-2}{k}$  combinations of  $(k + 1)$ th order whose first element is 2 (this is the number of combinations of  $k$ th order of the  $n - 1$  elements  $2, 3, \dots, n$ , the combinations no longer containing 1 because the combinations containing 1 have just been taken care of). Then there are  $\binom{n+k-3}{k}$  combinations of  $(k + 1)$ th order of the  $n - 2$  elements  $3, 4, \dots, n$  whose first element is 3, etc., and, by (13),

$$\binom{n+k-1}{k} + \binom{n+k-2}{k} + \dots + \binom{k}{k} = \sum_{s=0}^{n-1} \binom{k+s}{k} = \binom{n+k}{k+1}.$$

(d)  $a^k b^{n-k}$  is obtained by picking  $k$  of the  $n$  factors

$$(a + b)(a + b) \cdots (a + b) \quad (n \text{ factors})$$

and choosing  $a$  from each of  $k$  factors (and  $b$  from the remaining  $n - k$  factors); by Theorem 3, this can be done in  $\binom{n}{k}$  ways.

(e) Apply the binomial theorem to

$$(1 + b)^p (1 + b)^q = (1 + b)^{p+q}.$$

$b^r$  has the coefficient  $\binom{p+q}{r}$  on the right and  $\sum_{k=0}^r \binom{p}{k} \binom{q}{r-k}$  on the left.

### SECTION 24.5. Random Variables. Probability Distributions, page 1010

**Purpose.** To introduce the concepts of discrete and continuous random variables and their distributions (to be followed up by the most important special distributions in Secs. 24.7 and 24.8).

#### Main Content, Important Concepts

Random variable  $X$ , distribution function  $F(x)$

Discrete random variable, its probability function

Continuous random variable, its density

#### Comments on Content

The definitions in this section are general, but the student should not be scared because the number of distributions one needs in practice is small, as we shall see.

Discrete random variables occur in experiments in which we *count*, continuous random variables in experiments in which we *measure*.

For both kinds of random variables  $X$  the definition of the distribution function  $F(x)$  is the same, namely,  $F(x) = P(X \leq x)$ , so that it permits a uniform treatment of all  $X$ . For discrete  $X$  the function  $F(x)$  is piecewise constant; for continuous  $X$  it is continuous. For obtaining an impression of the distribution of  $X$  the probability function or density is more useful than  $F(x)$ .

### SOLUTIONS TO PROBLEM SET 24.5, page 1015

2. Using (10), we have

$$k \int_0^5 x^2 dx = \frac{5^3 k}{3} = 1, \quad k = \frac{3}{125}.$$

Hence  $F(x) = 0$  ( $x \leq 0$ ),  $F(x) = x^3/125$  ( $0 < x \leq 5$ ),  $F(x) = 1$  ( $x > 5$ ).

4.  $P(0 \leq x \leq 4) = \frac{1}{2}$ ;  $k = 1/8$ , so that

$$\int_{-c}^c k dx = \int_{-c}^c \frac{1}{8} dx = \frac{c}{4} = 0.95; \quad \text{hence} \quad c = 3.8.$$

6.  $f(x) = F'(x)$  gives  $f(x) = 0$  if  $x < 0$ ,  $f(x) = 3e^{-3x}$  if  $x > 0$ . This illustrates that a density may have discontinuities, whereas the distribution function of a continuous distribution must be continuous.

These first few problems should help the student to recognize the conceptual distinction between probability and density as well as the fact that in many cases the distribution function is given by different formulas over different intervals and that the same holds for the density.

Furthermore,  $F(x) = 0.9$  gives  $0.1 = e^{-3x}$ ; hence  $x = \frac{1}{3} \ln 10 = 0.7675$ .

8.  $k$  is obtained from

$$k \sum_{x=0}^{\infty} 2^{-x} = 2k = 1; \quad \text{hence} \quad k = \frac{1}{2}.$$

Furthermore,

$$P(X \geq 4) = 1 - P(X \leq 3)$$

where

$$P(X \leq 3) = \frac{1}{2}(1 + \frac{1}{2} + \frac{1}{4} + \frac{1}{8}) = \frac{1}{2}(2 - \frac{1}{8}) = 1 - \frac{1}{16}$$

so that the *answer* is  $1/16$ .

10. From the given distribution function and (9) we obtain

$$\frac{3}{4} \int_{-c}^c (1 - x^2) dx = \frac{3}{4} \left( 2c - \frac{2}{3} c^3 \right) = 0.95.$$

This gives the *answer*  $c = 0.8114$ .

12. Integrating the density, we obtain the distribution function

$$F(x) = 0 \text{ if } x < -1, \quad F(x) = \frac{1}{2}(x + 1)^2 \text{ if } -1 \leq x < 0, \\ F(x) = 1 - \frac{1}{2}(x - 1)^2 \text{ if } 0 \leq x < 1, \quad F(x) = 1 \text{ if } x \geq 1.$$

About 50 of the cans will contain 50 gallons or more because  $Y = 50$  corresponds to  $X = 0$  and  $F(0) = 0.5$ . Similarly,  $Y = 49.5$  corresponds to  $X = -0.5$  and  $F(-0.5) = 0.125$ ; this is the probability that a can will contain less than 49.5 gallons. Finally,  $F(-1) = 0$  is the answer to the last question.

14. By differentiation,

$$f(x) = 0.4x \quad \text{if } 2 < x < 3, \quad f(x) = 0 \quad \text{otherwise.}$$

Furthermore,

$$P(2.5 < X \leq 5) = F(5) - F(2.5) = 1 - 0.45 = 0.55,$$

that is, 55%.

16. To have the area under the density curve equal to 1, we must have  $k = 5$ . If  $A$  denotes "Defective" and  $B = A^c$ , we have

$$P(B) = 5 \int_{119.92}^{120.08} dx = 0.8, \quad P(A) = 0.2,$$

so that about 100 of the 500 axles will be defective.

18. The point of the last two problems is to tell the student to be careful with respect to  $<$  and  $\leq$  as well as with  $>$  and  $\geq$ , where the distinction does not matter in the continuous case but does matter for a discrete distribution. The answers are

$$13\frac{1}{3}\%, 53\frac{1}{3}\%, 33\frac{1}{3}\%, 0, 66\frac{2}{3}\%, 86\frac{2}{3}\%, 33\frac{1}{3}\%, 86\frac{2}{3}\%.$$

### SECTION 24.6. Mean and Variance of a Distribution, page 1016

**Purpose.** To introduce the two most important parameters of a distribution, the *mean*  $\mu$  of  $X$  (also called *expectation* of  $X$ ), which measures the central location of the values of  $X$ , and the *variance*  $\sigma^2$  of  $X$ , which measures the spread of those values.

#### Main Content, Important Concepts

Mean  $\mu$  given by (1)

Variance  $\sigma^2$  given by (2), standard deviation  $\sigma$

Standardized random variable (6)

**Short Courses.** Mention definitions of mean and variance and go on to the special distributions in the next two sections.

#### Comments on Content

Important practical applications follow in Secs. 24.7, 24.8, and later.

The transformation theorem (Theorem 2) will be basic in Sec. 24.8 and will have various applications in Chap. 25.

Moments (8) and (9) will play no great role in our further work, but would be more important in a more theoretical approach on a higher level. We shall use them in Sec. 25.2.

### SOLUTIONS TO PROBLEM SET 24.6, page 1019

2. From the defining formulas we compute

$$\mu = 0 + 0.384 + 2 \cdot 0.096 + 3 \cdot 0.008 = 0.6$$

and

$$\sigma^2 = 0.6^2 \cdot 0.512 + 0.4^2 \cdot 0.384 + 1.4^2 \cdot 0.096 + 2.4^2 \cdot 0.008 = 0.48.$$

This is a special case of the binomial distribution ( $n = 3$ ,  $p = 0.2$ ) to be considered in the next section; the point of this and similar problems is that the student gets a



feel for the concepts of mean and variance, before applying standard formulas for those quantities in the case of special distributions.

4. Theorem 2 gives

$$\mu^* = -\frac{8}{3} + 5 = \frac{7}{3} \quad \text{and} \quad \sigma^{*2} = \frac{16}{18} = \frac{8}{9}.$$

6. We obtain

$$\mu = \int_0^{\infty} 2xe^{-2x} dx = \frac{1}{2}, \quad \sigma^2 = \int_0^{\infty} 2(x - \frac{1}{2})^2 e^{-2x} dx = \frac{1}{4}.$$

8. Writing  $k = 0.001$  (and in fact for any positive  $k$ ) we obtain by integrating by parts

$$\mu = k \int_0^{\infty} xe^{-kx} dx = \frac{1}{k}.$$

Hence in our case the answer is 1000 hours.

10. About 35

12. We are asking for the sale  $x$  such that  $F(x) = 0.95$ . Integration of  $f(x)$  gives

$$F(x) = 3x^2 - 2x^3 \quad \text{if} \quad 0 \leq x < 1.$$

From this we get the solution 0.865, meaning that with a probability of 95% the sale will not exceed 8650 gallons (because we measure here in ten thousands of gallons). Thus

$$P(X \leq 0.865) = 0.95$$

and the complementary event that the sale will exceed 8650 gallons thus has a 5% chance,

$$P(X > 0.865) = 0.05$$

and then the tank will be empty if it has a capacity of 8650 gallons.

14. 1.45%, because for nondefective bolts we obtain

$$\begin{aligned} k \int_{1-0.09}^{1+0.09} f(x) dx &= 750 \int_{0.91}^{1.09} (x - 0.9)(1.1 - x) dx \\ &= 750 \cdot 2 \int_0^{0.09} (0.1 + z)(0.1 - z) dz \\ &= 0.9855. \end{aligned}$$

16. **Team Project.** (a)  $E(X - \mu) = E(X) - \mu E(1) = \mu - \mu = 0$ . Furthermore,

$$\begin{aligned} \sigma^2 &= E([X - \mu]^2) = E(X^2 - 2\mu X + \mu^2) \\ &= E(X^2) - 2\mu E(X) + \mu^2 E(1) \end{aligned}$$

where  $E(X) = \mu$  and  $E(1) = 1$ , so that the result follows. The formula obtained has various practical and theoretical applications.

(b)  $g(X) = X$  and the definition of expectation gives the defining formula for the mean. Similarly for (11). For  $E(1)$  we get the sum of all possible values or the integral of the density taken over the  $x$ -axis, and in both cases the value is 1 because of (6) and (10) in Sec. 24.5.

- (c)  $E(X^k) = (b^{k+1} - a^{k+1})/[(b - a)(k + 1)]$  by straightforward integration.  
 (d) Set  $x - \mu = t$ , write  $\tau$  instead of  $t$ , set  $\tau = -t$ , and use  $f(\mu - t) = f(\mu + t)$ . Then

$$\begin{aligned} E([X - \mu]^3) &= \int_{-\infty}^{\infty} t^3 f(\mu + t) dt = \int_{-\infty}^0 \tau^3 (f(\mu + \tau)) d\tau + \int_0^{\infty} t^3 f(\mu + t) dt \\ &= \int_{\infty}^0 (-t)^3 f(\mu - t)(-dt) + \int_0^{\infty} t^3 f(\mu + t) dt = 0. \end{aligned}$$

- (e)  $\mu = 2, \sigma^2 = 2, \gamma = 4/2^{3/2} = \sqrt{2}$   
 (g)  $f(1) = \frac{1}{2}, f(-4) = \frac{1}{3}, f(5) = \frac{1}{6}$ . But for distributions of interest in applications, the skewness will serve its purpose.

### SECTION 24.7. Binomial, Poisson, and Hypergeometric Distributions, page 1020

**Purpose.** To introduce the three most important *discrete* distributions and to illustrate them by typical applications.

#### Main Content, Important Concepts

Binomial distribution (2)–(4)

Poisson distribution (5), (6)

Hypergeometric distribution (8)–(10)

**Short Courses.** Discuss the binomial and hypergeometric distributions in terms of Examples 1 and 4.

#### Comments on Content

The “symmetric case”  $p = q = 1/2$  of the binomial distribution with probability function (2\*) is of particular practical interest. Formulas (3) and (4) will be needed from time to time. The approximation of the binomial distribution by the normal distribution will be discussed in the next section.

### SOLUTIONS TO PROBLEM SET 24.7, page 1025

2. The complementary event of not hitting the target has the probability  $0.9^{10}$ , so that the *answer* is  $P = 1 - 0.9^{10} = 65\%$ .  
 4. The mean is  $\mu = np = 50 \cdot 0.03$ , so that we get

$$f(x) = \binom{50}{x} 0.03^x 0.97^{50-x} \approx 1.5^x e^{-1.5}/x!$$

The numerical values are 0.223, 0.335, 0.251, 0.126, 0.047, 0.014. Note that their sum is 0.996, leaving 0.4% for all the other remaining possibilities together (except for a roundoff error).

6. Let  $X$  be the number of calls per minute. By assumption the average number of calls per minute is  $300/60 = 5$ . Hence  $X$  has a Poisson distribution with mean  $\mu = 5$ . By assumption, the board is overtaxed if  $X > 10$ . From Table A6, App. 5, we see that the complementary event  $X \leq 10$  has probability

$$P(X \leq 10) = 0.9863.$$

Hence the answer is 1.4%.

8. Let  $X$  be the number of defective screws in a sample of size  $n$ . The process will be halted if  $X \geq 1$ . The manufacturer wants  $n$  to be such that  $P(X \geq 1) \approx 0.95$  when  $p = 0.1$ , thus  $P(X = 0) = q^n = 0.9^n \approx 0.05$ , and  $n \ln 0.9 \approx \ln 0.05$ ,  $n = 28.4$ . Answer:  $n = 28$  or  $29$ .

It is perhaps worthwhile to point to the fact that the situation is typical; in the case of a discrete distribution, one will in general not be able to fulfill percentage requirements exactly.

10.  $0.99^{10} = 90.4\%$
12. (a)  $\mu = 6$  defects per 300 m,  $f(x) = 6^x e^{-6}/x!$ ,  
 (b)  $f(0) = e^{-6} = 0.00248 \approx 0.25\%$
14. For this problem, the hypergeometric distribution has the probability function

$$f(x) = \binom{5}{x} \binom{15}{3-x} / \binom{20}{3}.$$

The numeric values are

| $x$        | 0                  | 1                  | 2                  | 3                 |
|------------|--------------------|--------------------|--------------------|-------------------|
| $P(X = x)$ | $\frac{455}{1140}$ | $\frac{525}{1140}$ | $\frac{150}{1140}$ | $\frac{10}{1140}$ |

These values sum up to 1, as they should.

16. **Team Project.** (a) In each differentiation we get a factor  $x_j$  by the chain rule, so that

$$G^{(k)}(t) = \sum_j x_j^k e^{tx_j} f(x_j).$$

If we now set  $t = 0$ , the exponential function becomes 1 and we are left with the definition of  $E(X^k)$ . Similarly for a continuous random variable.

- (d) By differentiation,

$$G'(t) = n(pe^t + q)^{n-1}pe^t,$$

$$G''(t) = n(n-1)(pe^t + q)^{n-2}(pe^t)^2 + n(pe^t + q)^{n-1}pe^t.$$

This gives, since  $p + q = 1$ ,

$$E(X^2) = G''(0) = n(n-1)p^2 + np.$$

From this we finally obtain the desired result,

$$\sigma^2 = E(X^2) - \mu^2 = n(n-1)p^2 + np - n^2p^2 = npq.$$

- (e)  $G(t)$  gives  $G(0) = 1$  and furthermore,

$$G'(t) = e^{-\mu} \exp[\mu e^t] \mu e^t = \mu e^t G(t)$$

$$G''(t) = \mu e^t [G(t) + G'(t)]$$

$$E(X^2) = G''(0) = \mu + \mu^2$$

$$\sigma^2 = E(X^2) - \mu^2 = \mu.$$

- (f) By definition,

$$\mu = \sum x f(x) = \frac{1}{\binom{N}{n}} \sum x \binom{M}{x} \binom{N-M}{n-x}$$

(summation over  $x$  from 0 to  $n$ ). Now

$$\begin{aligned} x \binom{M}{x} &= \frac{xM(M-1)\cdots(M-x+1)}{x!} \\ &= \frac{M(M-1)\cdots(M-x+1)}{(x-1)!} \\ &= M \binom{M-1}{x-1}. \end{aligned}$$

Thus

$$\mu = \frac{M}{\binom{N}{n}} \sum \binom{M-1}{x-1} \binom{N-M}{n-x}.$$

Now (14), Sec. 24.4, is

$$\sum \binom{p}{k} \binom{q}{r-k} = \binom{p+q}{r}$$

(summation over  $k$  from 0 to  $r$ ). With  $p = M - 1$ ,  $k = x - 1$ ,  $q = N - M$ ,  $r - k = n - x$  we have  $p + q = N - 1$ ,  $r = k + n - x = n - 1$  and the formula gives

$$\mu = \frac{M}{\binom{N}{n}} \binom{N-1}{n-1} = n \frac{M}{N}.$$

### SECTION 24.8. Normal Distribution, page 1026

**Purpose.** To discuss Gauss's normal distribution, the practically and theoretically most important distribution. Use of the normal tables in App. 5.

#### Main Content, Important Concepts

Normal distribution, its density (1) and distribution function (2)

Distribution function  $\Phi(z)$ , Tables A7, A8 in App. 5

De Moivre–Laplace limit theorem

**Short Course.** Emphasis on the use of Tables A7 and A8 in terms of some of the given examples and problems.

#### Comments on Content

Although the normal tables become superfluous when a CAS (Maple, Mathematica, etc.) is used, their discussion may be advisable for a better understanding of the distribution and its numerical values.

Applications of the *De Moivre–Laplace limit theorem* follow in Chap. 25.

*Bernoulli's law of large numbers* is included in the problem set.

### SOLUTIONS TO PROBLEM SET 24.8, page 1031

$$2. \Phi\left(\frac{126 - 120}{4}\right) = \Phi(1.5) = 0.9332, 1 - \Phi\left(\frac{116 - 120}{4}\right) = 1 - \Phi(-1) = 0.8413.$$

Similarly,

$$\begin{aligned}\Phi\left(\frac{130-120}{4}\right) - \Phi\left(\frac{125-120}{4}\right) &= \Phi(2.5) - \Phi(1.25) \\ &= 0.9938 - 0.8944 = 0.0994.\end{aligned}$$

4. We obtain  $c = \mu = 4.2$  and, furthermore,

$$\Phi\left(\frac{c-4.2}{0.2}\right) = 0.9, \quad \frac{c-4.2}{0.2} = 1.282, \quad c = 4.4563$$

and

$$\Phi\left(\frac{c}{0.2}\right) = 0.995, \quad \frac{c}{0.2} = 2.576 \quad c = 0.515.$$

6. Smaller. This should help the student in qualitative thinking and an understanding of standard deviation and variance.

8. We get the maximum load  $c$  from the condition

$$P(X \leq c) = \Phi\left(\frac{c-1250}{55}\right) = 5\%.$$

By Table A8 in App. 5,

$$\frac{c-1250}{55} = -1.645, \quad c = 1160 \text{ kg.}$$

10. About 680 (Fig. 520a)

12. The complementary event has the probability

$$P(X \leq 15000) = \Phi\left(\frac{15000-12000}{2000}\right) = \Phi(1.5) = 0.9332.$$

Hence the *answer* is 6.7%.

14. **Team Project.** (c) Let  $e$  denote the exponential function in (1). Then

$$(\sigma\sqrt{2\pi}f)'' = \left(-\frac{x-\mu}{\sigma^2}e\right)' = \left(-\frac{1}{\sigma^2} + \left(\frac{x-\mu}{\sigma^2}\right)^2\right)e = 0, \quad (x-\mu)^2 = \sigma^2,$$

hence  $x = \mu \pm \sigma$ .

(d) Proceeding as suggested, we obtain

$$\begin{aligned}\Phi^2(\infty) &= \frac{1}{\sqrt{2\pi}} \int_{-\infty}^{\infty} e^{-u^2/2} du \frac{1}{\sqrt{2\pi}} \int_{-\infty}^{\infty} e^{-v^2/2} dv \\ &= \frac{1}{2\pi} \int_{-\infty}^{\infty} \int_{-\infty}^{\infty} e^{-u^2/2} e^{-v^2/2} du dv = \frac{1}{2\pi} \int_0^{2\pi} \int_0^{\infty} e^{-r^2/2} r dr d\theta.\end{aligned}$$

The integral over  $\theta$  equals  $2\pi$ , which cancels the factor in front, and the integral over  $r$  equals 1, which proves the desired result.

(e) Writing  $\beta$  instead of  $\sigma$  in (1) and using  $(x - \mu)/\beta = u$  and  $dx = \beta du$ , we obtain

$$\begin{aligned}\sigma^2 &= \frac{1}{\sqrt{2\pi}\beta} \int_{-\infty}^{\infty} (x - \mu)^2 \exp\left[-\frac{1}{2}\left(\frac{x - \mu}{\beta}\right)^2\right] dx \\ &= \frac{1}{\sqrt{2\pi}\beta} \int_{-\infty}^{\infty} \beta^2 u^2 e^{-u^2/2} \beta du = \frac{\beta^2}{\sqrt{2\pi}} \int_{-\infty}^{\infty} u^2 e^{-u^2/2} du \\ &= \frac{\beta^2}{\sqrt{2\pi}} \int_{-\infty}^{\infty} (-u)(-ue^{-u^2/2}) du \\ &= \beta^2 \left[ \frac{1}{\sqrt{2\pi}} (-u)e^{-u^2/2} \Big|_{-\infty}^{\infty} + \frac{1}{\sqrt{2\pi}} \int_{-\infty}^{\infty} e^{-u^2/2} du \right] = \beta^2(0 + 1) = \beta^2.\end{aligned}$$

(f) We have

$$P\left(\left|\frac{X}{n} - p\right| < \epsilon\right) = P([p - \epsilon]n < X < [p + \epsilon]n)$$

and apply (11) with  $a = (p - \epsilon)n$ ,  $b = (p + \epsilon)n$ . Then, since  $np$  cancels,

$$\beta = (\epsilon n + 0.5)/\sqrt{npq}, \quad \alpha = -\beta,$$

and  $\alpha \rightarrow -\infty$ ,  $\beta \rightarrow \infty$  as  $n \rightarrow \infty$ . Hence the above probability approaches  $\Phi(\infty) - \Phi(-\infty) = 1 - 0 = 1$ .

(g) Set  $x^* = c_1x + c_2$ . Then  $(x - \mu)/\sigma = (x^* - \mu^*)/\sigma^*$  and

$$\begin{aligned}F(x^*) &= P(X^* \leq x^*) \\ &= P(X \leq x) \\ &= \Phi((x - \mu)/\sigma) \\ &= \Phi((x^* - \mu^*)/\sigma^*).\end{aligned}$$

## SECTION 24.9. Distributions of Several Random Variables, page 1032

**Purpose.** To discuss distributions of two-dimensional random variables, with an extension to  $n$ -dimensional random variables near the end of the section.

### Main Content, Important Concepts

Discrete two-dimensional random variables and distributions

Continuous two-dimensional random variables and distributions

Marginal distributions

Independent random variables

Addition of means and variances

**Short Courses.** Omit this section. (Use the addition theorems for means and variances in Chap. 25 without proof.)

### Comments on Content

The addition theorems (Theorems 1 and 3) resulting from the present material will be needed in Chap. 25; this is the main reason for the inclusion of this section.

Note well that the addition theorem for variances holds for *independent* random variables only. In contrast, the addition of means is true without that condition.

**SOLUTIONS TO PROBLEM SET 24.9, page 1040**

2. The answers are 0 and 1/8. Since the density is constant in that triangle, these results can be read off from a sketch of the triangle and the regions determined by the inequalities  $x > 2$ ,  $y > 2$  and  $x \leq 1$ ,  $y \leq 1$ , respectively, without any integrations.
4. We have to integrate  $f(x, y) = 1/8$  over  $y$  from 0 to  $4 - x$ , where this upper integration limit follows from  $x + y = 4$ . This gives the density of the desired marginal distribution in the form

$$f_1(x) = \int_0^{4-x} \frac{1}{8} dy = \frac{1}{2} - \frac{1}{8}x \quad \text{if } 0 \leq x \leq 4 \quad \text{and } 0 \text{ otherwise.}$$

6. By Theorem 1 the mean is  $10\,000 \cdot 10 = 100$  kg. By Theorem 3, assuming independence (which is reasonable), we find the variance  $10\,000 \cdot (0.05)^2 = 25$ , hence the standard deviation 5 grams. Note that the mean is multiplied by  $n = 10\,000$ , whereas the standard deviation is multiplied only by  $\sqrt{n} = 100$ .
8. By Theorem 1 the mean is 77 lb. By Theorem 3, assuming independence, we get the variance  $0.01 + 0.64$ , hence the standard deviation  $\sqrt{0.65} = 0.806$  lb.
10. The distributions in Prob. 17 and Example 1
12. (a) From the given distributions we obtain

$$f_1(x) = 50 \text{ if } 0.99 < x < 1.01 \text{ and } 0 \text{ otherwise,}$$

$$f_2(y) = 50 \text{ if } 1.00 < y < 1.02 \text{ and } 0 \text{ otherwise.}$$

(b) A pin fits that hole if  $X < 1$ , and  $P(X < 1) = 50\%$ .

14.  $(X, Y)$  takes a value in  $A, B, C$ , or  $D$  (see the figure) with probability  $F(b_1, b_2)$ , a value in  $A$  or  $C$  with probability  $F(a_1, b_2)$ , a value in  $C$  or  $D$  with probability  $F(b_1, a_2)$ , a value in  $C$  with probability  $F(a_1, a_2)$ , hence a value in  $B$  with probability given by the right side of (2).

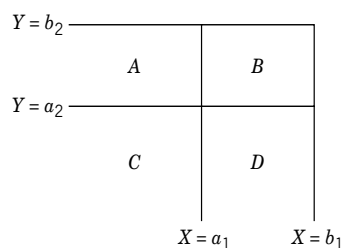

16.  $x^2 + y^2 = 1$  implies  $y = \pm\sqrt{1-x^2}$ ,  $x = \pm\sqrt{1-y^2}$ ; this gives the limits of integration in the integrals for the marginal densities.  $k$  times the area  $\pi$  must equal 1, hence  $k = 1/\pi$ . The marginal distributions have the densities

$$f_1(x) = \int f(x, y) dy = \frac{1}{\pi} \int_{-\sqrt{1-x^2}}^{\sqrt{1-x^2}} dy = \frac{2}{\pi} \sqrt{1-x^2} \quad \text{if } -1 \leq x \leq 1$$

and

$$f_2(y) = \int f(x, y) dx = \frac{1}{\pi} \int_{-\sqrt{1-y^2}}^{\sqrt{1-y^2}} dx = \frac{2}{\pi} \sqrt{1-y^2} \quad \text{if } -1 \leq y \leq 1$$

and 0 otherwise. Furthermore,

$$P = \frac{1}{\pi} \cdot \pi \cdot \frac{1}{4} = 25\%$$

(without integration).

18. No. Whereas for the mean it is *not* essential that the trials are not independent and one still obtains from  $\mu = M/N$  (single trial) the result  $\mu = nM/N$  ( $n$  trials) via Theorem 1, one cannot use Theorem 3 here; indeed, the variance  $\sigma^2 = M(N - M)/N^2$  (single trial) does not lead to (10), Sec. 24.7.
20. In the continuous case, (18) is obtained from (17) by differentiation, and (17) is obtained from (18) by integration. In the discrete case the proof results from the following theorem. *Two random variables  $X$  and  $Y$  are independent if and only if the events of the form  $a_1 < X \leq b_1$  and  $a_2 < Y \leq b_2$  are independent.* This theorem can be proved as follows. From (2), Sec. 24.5, we have

$$P(a_1 < X \leq b_1)P(a_2 < Y \leq b_2) = [F_1(b_1) - F_1(a_1)][F_2(b_2) - F_2(a_2)].$$

In the case of independence of the variables  $X$  and  $Y$  we conclude from (17) that the expression on the right equals

$$F(b_1, b_2) - F(a_1, b_2) - F(b_1, a_2) + F(a_1, a_2).$$

Hence, by (2),

$$P(a_1 < X \leq b_1)P(a_2 < Y \leq b_2) = P(a_1 < X \leq b_1, a_2 < Y \leq b_2).$$

This means independence of  $a_1 < X \leq b_1$  and  $a_2 < Y \leq b_2$ ; see (14), Sec. 24.3. Conversely, suppose that the events are independent for any  $a_1, b_1, a_2, b_2$ . Then

$$P(a_1 < X \leq b_1)P(a_2 < Y \leq b_2) = P(a_1 < X \leq b_1, a_2 < Y \leq b_2).$$

Let  $a_1 \rightarrow -\infty$ ,  $a_2 \rightarrow -\infty$  and set  $b_1 = x$ ,  $b_2 = y$ . This yields (17), that is,  $X$  and  $Y$  are independent.

### SOLUTIONS TO CHAP. 24 REVIEW QUESTIONS AND PROBLEMS, page 1041

22.  $Q_L = 210$ ,  $Q_M = 212$ ,  $Q_U = 215$

24.  $\bar{x} = 211.9$ ,  $s = 4.0125$ ,  $s^2 = 16.1$

26. *HHH, HHT, HTH, THH, HTT, THT, TTH, TTT*

28.  $F(x) = 0$  if  $x < 0$ ,  $F(x) = 0.80816$  if  $0 \leq x < 1$ ,  
 $F(x) = 0.99184$  if  $1 \leq x < 2$ ,  $F(x) = 1$  if  $x \geq 2$

30. Obviously,  $A \subseteq B$  implies  $A \cap B = A$ . Conversely, if  $A \cap B = A$ , then every element of  $A$  must also be in  $B$ , by the definition of intersection; hence  $A \subseteq B$ .

32.  $\binom{6}{2} = \binom{6}{4} = 15$

34.  $42/90$ ,  $42/90$ ,  $6/90$ ,  $0$ ,  $48/90$

36. We first need

$$\mu = 2 \int_0^1 x(1-x) dx = 2 \left( \frac{1}{2} - \frac{1}{3} \right) = \frac{1}{3}.$$



In the further integrations we can use the defining integrals of  $E[X - \mu]^2]$  and  $E[(X - \mu)^3]$  or, more simply,

$$\sigma^2 = E(X^2) - \mu^2 = 2 \int_0^1 x^2(1-x) dx - \frac{1}{9} = 2 \left( \frac{1}{3} - \frac{1}{4} \right) - \frac{1}{9} = \frac{1}{18}$$

and similarly,

$$\begin{aligned} E[(X - \mu)^3] &= E(X^3) - 3\mu E(X^2) + 3\mu^2 E(X) - \mu^3 \\ &= E(X^3) - 3\mu E(X^2) + 2\mu^3 \\ &= 2 \int_0^1 x^3(1-x) dx - 3 \cdot \frac{1}{3} \cdot \frac{1}{6} + \frac{2}{27} \\ &= 2 \left( \frac{1}{4} - \frac{1}{5} \right) - \frac{1}{6} + \frac{2}{27} = \frac{1}{135}. \end{aligned}$$

This gives

$$\gamma = \frac{18\sqrt{18}}{5 \cdot 27} = \frac{2\sqrt{2}}{5}.$$

38.  $f(x) = 0.2$  if  $0 < x < 5$ ,  $f(x) = 0$  elsewhere
40. The 100 bags are normal with mean  $100 \cdot 50 = 5000$  kg and, assuming independence (which is reasonable), variance  $100 \cdot 1$ ; hence standard deviation 10 kg. Thus 5030 is just one of the two three-sigma limits, so that the answer is about 0.13%.

## CHAPTER 25 Mathematical Statistics

### Changes

Regression and a short introduction to correlation have been combined in the same section (Sec. 25.9).

### SECTION 25.1. Introduction. Random Sampling, page 1044

**Purpose.** To explain the role of (random) samples from populations.

#### Main Content, Important Concepts

Population

Sample

Random numbers, random number generator

Sample mean:  $\bar{x}$ ; see (1)

Sample variance  $s^2$ ; see (2)

#### Comments on Content

Sample mean and sample variance are the two most important parameters of a sample.  $\bar{x}$  measures the central location of the sample values and  $s^2$  their spread (their variability). Small  $s^2$  may indicate high quality of production, high accuracy of measurement, etc.

Note well that  $\bar{x}$  and  $s^2$  will generally vary from sample to sample taken from the same population, whose mean  $\mu$  and variance  $\sigma^2$  are unique, of course. This is an important conceptual distinction that should be mentioned explicitly to the students.

### SECTION 25.2. Point Estimation of Parameters, page 1046

**Purpose.** As a first statistical task we discuss methods for obtaining approximate values of unknown population parameters from samples; this is called *estimation of parameters*.

#### Main Content, Important Concepts

Point estimate, interval estimate

Method of moments

Maximum likelihood method

### SOLUTIONS TO PROBLEM SET 25.2, page 1048

2. Put  $\mu = 0$  in Example 1 and proceed with the second equation in (8), as in the example, to get the estimate

$$\tilde{\sigma}^2 = \frac{1}{n} \sum_{i=1}^n x_i^2.$$

4. The likelihood function is (we can drop the binomial factors)

$$\begin{aligned} \ell &= p^{k_1} (1-p)^{n-k_1} \cdots p^{k_m} (1-p)^{n-k_m} \\ &= p^{k_1 + \cdots + k_m} (1-p)^{nm - (k_1 + \cdots + k_m)}. \end{aligned}$$

The logarithm is

$$\ln \ell = (k_1 + \cdots + k_m) \ln p + [nm - (k_1 + \cdots + k_m)] \ln(1 - p).$$

Equating the derivative with respect to  $p$  to zero, we get, with a factor  $-1$  from the chain rule,

$$(k_1 + \cdots + k_m) \frac{1}{p} = [nm - (k_1 + \cdots + k_m)] \frac{1}{1 - p}.$$

Multiplication by  $p(1 - p)$  gives

$$(k_1 + \cdots + k_m)(1 - p) = [nm - (k_1 + \cdots + k_m)]p.$$

By simplification,

$$k_1 + \cdots + k_m = nmp.$$

The result is

$$\hat{p} = \frac{1}{nm} \sum_{i=1}^m k_i.$$

6. We obtain

$$\begin{aligned} \ell &= f(x_1)f(x_2) \cdots f(x_n) \\ &= p(1 - p)^{x_1-1} p(1 - p)^{x_2-1} \cdots p(1 - p)^{x_n-1} \\ &= p^n (1 - p)^{x_1 + \cdots + x_n - n}. \end{aligned}$$

The logarithm is

$$\ln \ell = n \ln p + \left( \sum_{m=1}^n x_m - n \right) \ln(1 - p).$$

Differentiation with respect to  $p$  gives, with a factor  $-1$  from the chain rule,

$$\frac{\partial \ln \ell}{\partial p} = \frac{n}{p} - \sum_{m=1}^n \frac{x_m - n}{1 - p}.$$

Equating this derivative to zero gives

$$n(1 - \hat{p}) = \hat{p} \left( \sum_{m=1}^n x_m - n \right).$$

Thus  $\hat{p} = 1/\bar{x}$ .

8.  $\hat{p} = 2/(7 + 6) = 2/13$ , by Prob. 6.

10.  $\ell = 1(b - a)^n$  is maximum if  $b - a$  is as small as possible, that is,  $a$  equal to the smallest sample value and  $b$  equal to the largest.

12.  $\mu = 1/\theta$ ,  $\hat{\mu} = \bar{x}$

14.  $\hat{\theta} = 1/\bar{x} = 2$ ,  $F(x) = 1 - e^{-2x}$  if  $x \geq 0$  and 0 otherwise. A graph shows that the step function  $\tilde{F}(x)$  (the sample distribution function) approximates  $F(x)$  reasonably well. (For goodness of fit, see Sec. 25.7.)

### SECTION 25.3. Confidence Intervals, page 1049

**Purpose.** To obtain interval estimates ("confidence intervals") for unknown population parameters for the normal distribution and other distributions.

**Main Content, Important Concepts**

- Confidence interval for  $\mu$  if  $\sigma^2$  is known
- Confidence interval for  $\mu$  if  $\sigma^2$  is unknown
- $t$ -distribution, its occurrence (Theorem 2)
- Confidence interval for  $\sigma^2$
- Chi-square distribution, its occurrence (Theorem 3)
- Distribution of a sum of independent normal random variables
- Central limit theorem

**Comments on Content**

The present methods are designed for the normal distribution, but the central limit theorem permits their extension to other distributions, provided we can use sufficiently large samples.

The theorems giving the theory underlying the present methods also serve as the theoretical basis of tests in the next section. Hence these theorems are of basic importance.

We see that, although our task is the development of methods for the normal distribution, other distributions ( $t$  and chi-square) appear in the mathematical foundation of those methods.

**SOLUTIONS TO PROBLEM SET 25.3, page 1057**

2. In Prob. 1 we have  $\bar{x} = 40.667$ ,  $k = 3.201$ . Instead of  $c = 1.96$  we now have  $c = 2.576$  in Table 25.1. Hence  $k$  (and thus the length of the interval) is multiplied by  $2.576/1.960$ , so that the new  $k$  is 4.207, giving the longer interval

$$\text{CONF}_{0.99}\{36.460 \leq \mu \leq 44.874\}.$$

4.  $k = 1.645 \cdot 0.5/\sqrt{100} = 0.08225$ ,  $\text{CONF}_{0.9}\{212.218 \leq \mu \leq 212.382\}$ .

The large sample size and small population variance have given a short interval, although the probability that it does not contain  $\mu$  is 10%, due to the choice of  $\gamma$ . But for larger  $\gamma$  ( $<1$ ) the interval is still rather short.

6. This is a fast way of limited accuracy. More importantly, it should help the student get a better understanding of the whole idea of confidence intervals.

From the figure we obtain  $L/\sigma = 2k/\sigma = k = 0.27$ , approximately. Thus the confidence interval is roughly  $\text{CONF}_{0.95}\{119.73 \leq \mu \leq 120.27\}$ . Calculation gives the more exact value  $k = 0.277$ .

8.  $n - 1 = 3$  degrees of freedom;  $F(c) = 0.995$  gives  $c = 5.84$ . From the sample we compute

$$\bar{x} = 426.25, \quad s^2 = 39.58.$$

Hence  $k = 18.37$  in Table 25.2, Step 4. This gives the confidence interval

$$\text{CONF}_{0.99}\{407 \leq \mu \leq 445\}.$$

10.  $n - 1 = 5$ ;  $F(c) = 0.995$  gives  $c = 4.03$ . From the sample we compute

$$\bar{x} = 9533, \quad s^2 = 49667.$$

Hence  $k = 367$  in Table 25.2, Step 4. This gives the confidence interval

$$\text{CONF}_{0.99}\{9166 \leq \mu \leq 9900\}.$$

12.  $n - 1 = 4$ ;  $F(c) = 0.995$  gives  $c = 4.60$ . From the sample we compute

$$\bar{x} = 661.2, \quad s^2 = 22.70.$$

Hence  $k = 9.8$  in Table 25.2, Step 4. This gives the confidence interval

$$\text{CONF}_{0.99}\{651.3 \leq \mu \leq 671.1\}.$$

14.  $n = 24\,000$ ,  $\bar{x} = 12\,012$ ,  $\hat{p} = \bar{x}/n = 0.5005$ . Now the random variable

$$X = \text{Number of heads in } 24\,000 \text{ trials}$$

is approximately normal with mean  $24\,000p$  and variance  $24\,000p(1 - p)$ . Estimators are

$$24\,000\hat{p} = 12\,012 \quad \text{and} \quad 24\,000\hat{p}(1 - \hat{p}) = 5999.99.$$

For the standardized normal random variable we get from Table A8 in App. 5 (or from a CAS) and  $\Phi(c) = 0.995$  the value

$$c = 2.576 = \frac{c^* - 12\,012}{\sqrt{6000}}$$

and

$$c^* - 12\,012 = 2.576\sqrt{6000} = 199.5$$

so that

$$\text{CONF}_{0.99}\{11\,812 \leq \mu \leq 12\,212\}$$

and by division by  $n$ ,

$$\text{CONF}_{0.99}\{0.492 \leq p \leq 0.509\}.$$

16.  $n - 1 = 19$ ,  $c_1 = 8.91$ ,  $c_2 = 32.85$ ,  $19 \cdot 0.04 = 0.76$ ,  $k_1 = 0.76/8.91 = 0.086$ ,  $k_2 = 0.76/32.85 = 0.023$ . Hence

$$\text{CONF}_{0.95}\{0.023 \leq \sigma^2 \leq 0.086\}.$$

18.  $n - 1 = 7$  degrees of freedom,  $F(c_1) = 0.025$ ,  $c_1 = 1.69$ ,  $F(c_2) = 0.975$ ,  $c_2 = 16.01$  from Table A10. From the sample,

$$\bar{x} = 17.7625, \quad (n - 1)s^2 = 7s^2 = 0.73875.$$

Hence  $k_1 = 0.437$ ,  $k_2 = 0.046$ . The answer is

$$\text{CONF}_{0.95}\{0.046 \leq \sigma^2 \leq 0.437\}.$$

20.  $n - 1 = 9$  degrees of freedom,  $F(c_1) = 0.025$ ,  $c_1 = 2.70$ ,  $F(c_2) = 0.975$ ,  $c_2 = 19.02$  from Table A10. From the sample,

$$\bar{x} = 253.5, \quad 9s^2 = 54.5.$$

Hence  $k_1 = 54.5/2.70 = 20.19$ ,  $k_2 = 54.5/19.02 = 2.87$ . From Table 25.3 we thus obtain the (rather long!) confidence interval

$$\text{CONF}_{0.95}\{2.8 \leq \sigma^2 \leq 20.2\}.$$

22. By Theorem 1 in this section and by the hint, the distribution of  $4X_1 - X_2$  is normal with mean  $4 \cdot 23 - 4 = 88$  and variance  $16 \cdot 3 + 1 = 49$ .

24. By Theorem 1, the load  $Z$  is normal with mean  $40N$  and variance  $4N$ , where  $N$  is the number of bags. Now

$$P(Z \leq 2000) = \Phi\left(\frac{2000 - 40N}{2\sqrt{N}}\right) = 0.95$$

gives the condition

$$\frac{2000 - 40N}{2\sqrt{N}} \geq 1.645$$

by Table A8. The *answer* is  $N = 49$  (since  $N$  must be an integer).

### SECTION 25.4. Testing of Hypotheses. Decisions, page 1058

**Purpose.** Our third big task is testing of hypotheses. This section contains the basic ideas and the corresponding mathematical formalism. Applications to further tasks of testing follow in Secs. 25.5–25.7.

#### Main Content, Important Concepts

Hypothesis (null hypothesis)

Alternative (alternative hypothesis), one- and two-sided

Type I error (probability  $\alpha$  = significance level)

Type II error (probability  $\beta$ ;  $1 - \beta$  = power of a test)

Test for  $\mu$  with known  $\sigma^2$  (Example 2)

Test for  $\mu$  with unknown  $\sigma^2$  (Example 3)

Test for  $\sigma^2$  (Example 4)

Comparison of means (Example 5)

Comparison of variances (Example 6)

#### Comment on Content

Special testing procedures based on the present ideas have been developed for controlling the quality of production processes (Sec. 25.5), for assessing the quality of produced goods (Sec. 25.6), for determining whether some function  $F(x)$  is the unknown distribution function of some population (Sec. 25.7), and for situations in which the distribution of a population need not be known in order to perform a test (Sec. 25.8).

### SOLUTIONS TO PROBLEM SET 25.4, page 1067

2. If the hypothesis  $p = 0.5$  is true,  $X = \text{Number of heads in 4040 trials}$  is approximately normal with  $\mu = 2020$ ,  $\sigma^2 = 1010$  (Sec. 24.8). Hence

$$P(X \leq c) = \Phi\left[\frac{c - 2020}{\sqrt{1010}}\right] = 0.95, \quad c = 2072 > 2048,$$

do not reject the hypothesis.

4. Left-sided test,  $\sigma^2/n = 4/10 = 0.4$ . From Table A8 in App. 5 we obtain

$$P(\bar{X} \leq c)_{\mu=30.0} = \Phi\left(\frac{c - 30.0}{\sqrt{0.4}}\right) = 0.05.$$

Hence

$$c = 30.0 - 1.645\sqrt{0.4} = 28.96$$

and we reject the hypothesis.

(b) Right-sided test. We get

$$\bar{x} < c = 31.04$$

and do not reject the hypothesis.

6. We obtain

$$\begin{aligned}\eta(28.5) &= P(\bar{X} > 28.96)_{\mu=28.5} = 1 - P(\bar{X} \leq 28.96)_{\mu=28.5} \\ &= 1 - \Phi\left(\frac{28.96 - 28.50}{\sqrt{0.4}}\right) \\ &= 1 - \Phi(0.73) = 1 - 0.7673 = 0.2327.\end{aligned}$$

8. The test is two-sided. The variance is unknown, so we have to proceed as in the case of Example 3. From the sample we compute

$$t = \sqrt{10} (0.811 - 0.800) / \sqrt{0.000054} = 4.73.$$

Now from Table A9 in App. 5 with  $n - 1 = 9$  degrees of freedom and the condition

$$P(-c \leq T \leq c) = 0.95 \quad \text{we get} \quad c = 2.26.$$

Since  $t > c$ , we reject the hypothesis.

10. Hypothesis  $\mu_0 = 30\,000$ , alternative  $\mu > 30\,000$ . Using the given data and Table A9, we obtain

$$t = \sqrt{50} (32\,000 - 30\,000) / 4000 = 3.54 > c = 1.68.$$

Hence we reject the hypothesis and assert that the manufacturer's claim is justified.

12. Hypothesis  $H_0$ : Not better. Alternative  $H_1$ : Better. Under  $H_0$  the random variable

$$X = \text{Number of cases cured in 200 cases}$$

is approximately normal with mean  $\mu = np = 200 \cdot 0.7 = 140$  and variance  $\sigma^2 = npq = 42$ . From Table A8 and  $\alpha = 5\%$  we get

$$(c - 140) / \sqrt{42} = 1.645, \quad c = 140 + 1.645\sqrt{42} = 150.7.$$

Since the observed value 148 is not greater than  $c$ , we do not reject the hypothesis. This indicates that the results obtained so far do not establish the superiority.

14. We test the hypothesis  $\sigma_0^2 = 25$  against the alternative that  $\sigma^2 < 25$ . As in Example 4, we now get

$$Y = (n - 1)S^2 / \sigma_0^2 = 27S^2 / 25 = 1.08S^2.$$

From Table A10 with 27 degrees of freedom and the condition

$$P(Y < c) = \alpha = 5\% \quad \text{we get} \quad c = 16.2.$$

As in Example 4 we compute the corresponding

$$c^* = 16.2 / 1.08 = 15.00.$$

Now the observed value of  $S^2$  is  $s^2 = 3.5^2 = 12.25$ . Since this is less than  $c^*$  and the test is left-sided, we reject the hypothesis and assert that it will be less expensive to replace all batteries simultaneously.

16. We test the hypothesis  $\sigma_x^2 = \sigma_y^2$  against the alternative  $\sigma_x^2 > \sigma_y^2$ . We proceed as in Example 6. By computation,

$$v_0 = s_x^2 / s_y^2 = 350 / 61.9 = 5.65.$$

For  $\alpha = 5\%$  and (5, 6) degrees of freedom. Table A11 in App. 5 gives 4.39. Since 5.65 is greater, we reject the hypothesis and assert that the variance of the first population is greater than that of the second.

18. The test is two-sided. As in Example 5 we compute from (12)

$$t_0 = \sqrt{9} \frac{12 - 15}{\sqrt{4 + 4}} = -3.18.$$

Now Table A9 with  $9 + 9 - 2 = 16$  degrees of freedom gives from  $P(-c < T < c) = 0.95$  the value  $c = 2.12$ . Since  $-3.18 < -2.12$ , we reject the hypothesis.

### SECTION 25.5. Quality Control, page 1068

**Purpose.** Quality control is a testing procedure performed every hour (or every half hour, etc.) in an ongoing process of production in order to see whether the process is running properly (“is under control,” is producing items satisfying the specifications) or not (“is out of control”), in which case the process is being halted in order to search for the trouble and remove it. These tests may concern the mean, variance, range, etc.

#### Main Content

Control chart for the mean

Control chart for the variance

#### Comment on Content

Control charts have also been developed for the range, the number of defectives, the number of defects per unit, for attributes, etc. (see the problem set).

### SOLUTIONS TO PROBLEM SET 25.5, page 1071

2. The assertion follows from (6c) in Sec. 24.8. As the numeric values we obtain

$$\mu \pm 3\sigma/\sqrt{n} = 1 \pm 0.09/\sqrt{6} = 1 \pm 0.037,$$

so that LCL = 0.963 and UCL = 1.037.

4. LCL and UCL will correspond to a significance level  $\alpha$ , which, in general, is not equal to 1%.
6. LCL =  $n\mu_0 - 2.58\sigma\sqrt{n}$ , UCL =  $n\mu_0 + 2.58\sigma\sqrt{n}$ , as follows from Theorem 2 in Sec. 24.6.
8. LCL =  $5.00 - 2.58 \cdot 1.55/\sqrt{4} = 3$ , UCL = 7
10. Decrease by a factor  $\sqrt{2} = 1.41$ . By a factor  $2.58/1.96 = 1.32$  (see Table 25.1 in Sec. 25.3). Hence the two operations have almost the same effect.
12. The sample range tends to increase with increasing  $n$ , whereas  $\sigma$  remains unchanged.
14. Trend of sample means to increase. Abrupt change of sample means.
16. The random variable  $Z = \text{Number of defectives in a sample of size } n$  has the variance  $npq$ . Hence  $\bar{X} = Z/n$  has the variance  $\sigma^2 = npq/n^2 = 0.05 \cdot 0.95/100 = 0.000475$ . This gives

$$\text{UCL} = 0.05 + 3\sigma = 0.115.$$

From the given values we see that the process is out of control.



**SECTION 25.6. Acceptance Sampling, page 1073**

**Purpose.** This is a test for the quality of a produced lot designed to meet the interests of both the producer and the consumer of the lot, as expressed in the terms listed below.

**Main Content, Important Concepts**

Sampling plan, acceptance number, fraction defective

Operating characteristic curve (OC curve)

Acceptable quality level (AQL)

Rejectable quality level (RQL)

Rectification

Average outgoing quality limit (AOQL)

**Comments on Content**

Basically, acceptance sampling first leads to the hypergeometric distribution, which, however, can be approximated by the simpler Poisson distribution and simple formulas resulting from it, or in other cases by the binomial distribution, which can in turn be approximated by the normal distribution. Typical cases are included in the problem set.

**SOLUTIONS TO PROBLEM SET 25.6, page 1076**

2. We expect a decrease of values because of the exponential function in (3), which involves  $n$ . The probabilities are 0.9098 (down from 0.9825), 0.7358, 0.0404.
4.  $P(A; \theta) = e^{-20\theta}(1 + 20\theta)$  from (3). From Fig. 539 we find  $\alpha$  and  $\beta$ . For  $\theta = 1.5\%$  we obtain  $P(A; 0.015) = 96.3\%$ , hence  $\alpha = 3.7\%$ . Also  $\beta = P(A; 0.075) = 55.8\%$ , which is very poor.
6.  $AOQ(\theta) = \theta e^{-30\theta}(1 + 30\theta)$ ,  $AOQ' = 0$ ,  $\theta_{\max} = 0.0539$ ,  $AOQ(\theta_{\max}) = 0.0280$
8. The approximation is  $\theta^0(1 - \theta)^2$  and is fairly accurate, as the following values show:

| $\theta$ | Exact (2D) | Approximate |
|----------|------------|-------------|
| 0.0      | 1.00       | 1.00        |
| 0.2      | 0.63       | 0.64        |
| 0.4      | 0.35       | 0.36        |
| 0.6      | 0.15       | 0.16        |
| 0.8      | 0.03       | 0.04        |
| 1.0      | 0.00       | 0.00        |

10. From the definition of the hypergeometric distribution we now obtain

$$\begin{aligned}
 P(A; \theta) &= \binom{20\theta}{0} \binom{20 - 20\theta}{3} / \binom{20}{3} \\
 &= \frac{(20 - 20\theta)(19 - 20\theta)(18 - 20\theta)}{6840}.
 \end{aligned}$$

This gives  $P(A; 0.1) = 0.72$  (instead of 0.81 in Example 1) and  $P(A; 0.2) = 0.49$  (instead of 0.63), a decrease in both cases, as had to be expected.

12.  $1 - 0.99^5 = 0.05$ ,  $0.85^5 = 0.44$

14. For  $\theta = 0.05$  we should get  $P(A; \theta) = 0.98$ . (Figure 539 illustrates this, for different values.) Since  $n = 100$ , we get  $np = 5$  and the variance  $npq = 5 \cdot 0.95 = 4.75$ . Using the normal approximation of the binomial distribution, we thus obtain, with  $c$  to be determined,

$$\sum_{x=0}^c \binom{100}{x} 0.05^x 0.95^{100-x} \approx \Phi\left(\frac{c - 5 + 0.5}{\sqrt{4.75}}\right) - \Phi\left(\frac{0 - 5 - 0.5}{\sqrt{4.75}}\right) = 0.9800.$$

The second  $\Phi$ -term equals  $\Phi(-5.5/\sqrt{4.75}) = \Phi(-2.52) = 0.0059$  (Table A7). From this,  $\Phi((c - 4.5)/\sqrt{4.75}) = 0.9859$ , so that Table A8 gives

$$c = 4.50 + 2.19\sqrt{4.75} = 9.27.$$

Hence choose 9 or 10 as  $c$ .

16. By the binomial distribution,

$$\begin{aligned} P(A; \theta) &\approx \sum_{x=0}^1 \binom{n}{x} \theta^x (1 - \theta)^{n-x} \\ &= (1 - \theta)^{n-1} [1 + (n - 1)\theta], \end{aligned}$$

which in those special cases gives

$$(1 - \theta)(1 + \theta) = 1 - \theta^2 \quad (n = 2)$$

$$(1 - \theta)^2(1 + 2\theta) \quad (n = 3)$$

$$(1 - \theta)^3(1 + 3\theta) \quad (n = 4).$$

18. We have

$$P(A; \theta) \approx (1 - \theta)^5,$$

hence

$$AOQ(\theta) \approx \theta(1 - \theta)^5.$$

Now

$$[\theta(1 - \theta)^5]' = 0$$

gives  $\theta = 1/6$ , and from this,

$$AOQL = AOQ\left(\frac{1}{6}\right) = 0.067.$$

## SECTION 25.7. Goodness of Fit. $\chi^2$ -Test, page 1076

**Purpose.** The  $\chi^2$ -test is a test for a whole unknown distribution function, as opposed to the previous tests for unknown parameters in known types of distributions.

### Main Content

Chi-square ( $\chi^2$ ) test

Test of normality

### Comments on Content

The present method includes many practical problems, some of which are illustrated in the problem set.

Recall that the chi-square distribution also occurred in connection with confidence intervals and in our basic section on testing (Sec. 25.4).

**SOLUTIONS TO PROBLEM SET 25.7, page 1079**

2. The hypothesis that the coin is fair is accepted, in contrast with Prob. 1, because we now obtain

$$\chi_0^2 = \frac{(3 - 5)^2}{5} + \frac{(7 - 5)^2}{5} = 1.6 < 3.84.$$

4. From the sample and from Table A10 with  $n - 1 = 5$  degrees of freedom we obtain

$$\chi_0^2 = (9^2 + 8^2 + 11^2 + 4^2 + 10^2 + 2^2)/30 = 12.87 > c = 11.07.$$

Accordingly, we reject the hypothesis that the die is fair.

6.  $K = 2$  classes (dull, sharp). Expected values 10 dull, 390 sharp; 1 degree of freedom; hence

$$\chi_0^2 = \frac{49}{10} + \frac{49}{390} = 5.03 > 3.84.$$

Reject the claim. Here, two things are interesting. First, 16 dull knives (an excess of 60% over the expected value!) would not have been sufficient to reject the claim at the 5% level. Second, 49/10 contributes much more to  $\chi_0^2$  than 49/390 does; in other applications the situation will often be qualitatively similar.

8. The maximum likelihood estimates for the two parameters are  $\bar{x} = 59.87$ ,  $\hat{s} = 1.504$ .  $K - 1 - 2 = 2$  degrees of freedom. From Table A10 we get the critical value  $9.21 > \chi_0^2 = 6.22$ . Accept the hypothesis that the population from which the sample was taken is normally distributed.  $\chi_0^2$  is obtained as follows.

| $x$      | $\frac{x - \bar{x}}{s}$ | $\Phi\left(\frac{x - \bar{x}}{s}\right)$ | Expected | Observed | Terms in (1) |
|----------|-------------------------|--|----------|----------|--------------|
| 58.5     | -0.91                   | 0.181                                    | 14.31    | 14       | 0.01         |
| 59.5     | -0.25                   | 0.402                                    | 17.51    | 17       | 0.01         |
| 60.5     | 0.42                    | 0.662                                    | 20.50    | 27       | 2.06         |
| 61.5     | 1.08                    | 0.860                                    | 15.68    | 8        | 3.78         |
| $\infty$ |                         | 1.000                                    | 11.00    | 13       | 0.36         |

$$\chi_0^2 = 6.22$$

Slightly different results due to rounding are possible.

10. Let  $50 + b$  be that number. Then  $2b^2/50 > c$ ,  $b > 5\sqrt{c}$ ,  $50 + b = 60, 63, 64$ .  
 12.  $\hat{\mu} = \bar{x} = 23/50 = 0.46$ , 1 degree of freedom, since we estimated  $\mu$ . We thus obtain

$$\chi_0^2 = \frac{(33 - 31.56)^2}{31.56} + \frac{(11 - 14.52)^2}{14.52} + \frac{(6 - 3.34)^2}{3.34} = 3.04 < 3.84.$$

Hence we accept the hypothesis.

14. Expected  $2480/3 = 827$  cars per lane; accordingly,

$$\chi_0^2 = \frac{1}{827}(83^2 + 23^2 + 107^2) = 22.81 > 5.99$$

(2 degrees of freedom,  $\alpha = 5\%$ ). Hence we reject the hypothesis. (Note that even  $\alpha = 1\%$  or  $0.5\%$  would lead to the same conclusion.)

16. We test the hypothesis  $H_0$  that the number of defective rivets is the same for all three machines. Since

$$(7 + 8 + 12)/600 = 0.045$$

the expected number of defective rivets in 200 should be 9. Hence

$$\chi_0^2 = [(7 - 9)^2 + (8 - 9)^2 + (12 - 9)^2]/9 = 1.56.$$

Now from Table A10 with 2 degrees of freedom we get  $c = 5.99$  and conclude that the difference is not significant.

18.  $\bar{x} = 107$ ,  $\chi_0^2 = \frac{1}{107}(13^2 + 12^2 + 3^2 + 1^2 + 5^2) = 3.252 < 9.49$  (4 degrees of freedom), so that we accept the hypothesis of equal time-efficiency.

20. **Team Project.**  $n = 3 \cdot 77 = 231$ .

(a)  $a_j = 231/20 = 11.55$ ,  $K = 20$ ,  $\chi_0^2 = 24.32 < c = 30.14$  ( $\alpha = 5\%$ , 19 degrees of freedom). Accept the hypothesis.

(b)  $\chi_0^2 = 13.10 > c = 3.84$  ( $\alpha = 5\%$ , 1 degree of freedom). Reject the hypothesis.

(c)  $\chi_0^2 = 14.7 > c = 3.84$  ( $\alpha = 5\%$ , 1 degree of freedom). Reject the hypothesis.

### SECTION 25.8. Nonparametric Tests, page 1080

**Purpose.** To introduce the student to the ideas of nonparametric tests in terms of two typical examples selected from a wide variety of tests in that field.

#### Main Content

Median, a test for it

Trend, a test for it

#### Comment on Content

Both tasks have not yet been considered in the previous sections. Another approach to trend follows in the next section.

### SOLUTIONS TO PROBLEM SET 25.8, page 1082

2. Under the hypothesis that no adjustment is needed, shorter and longer pipes are equally probable. We drop the 4 pipes of exact length from the sample. Then the probability that under the hypothesis one gets 3 or fewer longer pipes among 18 pipes is, since  $np = 9$  and  $\sigma^2 = npq = 4.5$ ,

$$\begin{aligned} \sum_{x=0}^3 \binom{18}{x} \left(\frac{1}{2}\right)^{18} &\approx \Phi\left(\frac{3 - 9 + \frac{1}{2}}{\sqrt{4.5}}\right) - \Phi\left(\frac{0 - 9 - \frac{1}{2}}{\sqrt{4.5}}\right) \\ &= \Phi(-2.6) - \Phi(-4.5) = 0.0047 \end{aligned}$$

and we reject the hypothesis and assert that the process needs adjustment.

4. Let  $X =$  Number of positive values among 9 values. If the hypothesis is true, a value greater than  $20^\circ\text{C}$  is as probable as a value less than  $20^\circ\text{C}$ , and thus has probability  $1/2$ . Hence, under the hypothesis the probability of getting at most 1 positive value is

$$P = \left(\frac{1}{2}\right)^9 + 9 \cdot \left(\frac{1}{2}\right)^9 = 2\%.$$

Hence we reject the hypothesis and assert that the setting is too low.

6. We drop 0 from the sample. Let  $X =$  Number of positive values. Under the hypothesis we get the probability

$$P(X = 9) = \binom{9}{9} \left(\frac{1}{2}\right)^9 = 0.2\%.$$

Accordingly, we reject the hypothesis that there is no difference between  $A$  and  $B$  and assert that the observed difference is significant.

8. Under the hypothesis the probability of obtaining at most 3 negative differences (80 – 85, 90 – 95, 60 – 75) is

$$\left(\frac{1}{2}\right)^{15} \left[ 1 + \binom{15}{1} + \binom{15}{2} + \binom{15}{3} \right] = 1.76\%.$$

We reject the hypothesis and assert that  $B$  is better.

10. Hypothesis  $H_0: q_{25} = 0$ . Alternative  $H_1$ , say,  $q_{25} > 0$ . If  $H_0$  is true, a negative value has probability  $p = 0.25$ . Reject  $H_0$  if fewer than  $c$  negative values are observed, where  $c$  results from  $P(X \leq c)_{H_0} = \alpha$ .
14.  $n = 5$  values, with 2 transpositions, namely,

101.1 before 100.4 and 100.8,

so that from Table A12 we obtain

$$P(T \leq 2) = 0.117$$

and we do not reject the hypothesis.

16. We order by increasing  $x$ . Then we have 10 transpositions:

418 > 301, 352, 395, 375, 388

395 > 375, 388

465 > 455

521 > 455, 490.

Hypothesis *no trend*, alternative *positive trend*,  $P(T \leq 10) = 1.4\%$  by Table A12 in App. 5. Reject the hypothesis.

18.  $n = 8$  values, with 4 transpositions, namely,

41.4 before 39.6

43.3 before 39.6, 43.0

45.6 before 44.5.

Table A12 gives

$$P(T \leq 4) = 0.007.$$

Reject the hypothesis that the amount of fertilizer has no effect and assert that the yield increases with increasing amounts of fertilizer.

### SECTION 25.9. Regression. Fitting Straight Lines. Correlation, page 1083

**Purpose.** This is a short introduction to regression analysis, restricted to linear regression, and to correlation analysis; the latter is presented without proofs.

#### Main Content, Important Concepts

Distinction between regression and correlation

Gauss's least squares method

Sample regression line, sample regression coefficient

Population regression coefficient, a confidence interval for it

Sample covariance  $s_{xy}$

Sample correlation coefficient  $r$

Population covariance  $\sigma_{XY}$

Population correlation coefficient  $\rho$

Independence of  $X$  and  $Y$  implies  $\rho = 0$  ("uncorrelatedness")

Two-dimensional normal distribution

If  $(X, Y)$  is normal,  $\rho = 0$  implies independence of  $X$  and  $Y$ .

Test for  $\rho = 0$

### SOLUTIONS TO PROBLEM SET 25.9, page 1091

2.  $\sum x_i = 24$ ,  $\sum y_i = 13$ ,  $n = 4$ ,  $\sum x_i y_i = 79$ ,  $(n - 1)s_x^2 = 20$ , by (9a). Hence we obtain from (11)

$$k_1 = \frac{4 \cdot 79 - 24 \cdot 13}{4 \cdot 20} = 0.05.$$

This gives the *answer*

$$y - 3.25 = 0.05(x - 6), \quad \text{hence} \quad y = 2.95 + 0.05x.$$

4.  $n = 5$ ,  $\sum x_i = 85$ ,  $\bar{x} = 17$ ,  $\sum y_i = 75$ ,  $\bar{y} = 15$ ,  $\sum x_i y_i = 1184$ , hence

$$(n - 1)s_x^2 = 4s_x^2 = 74.$$

Hence (11) gives

$$k_1 = \frac{5 \cdot 1184 - 85 \cdot 75}{5 \cdot 74} = -1.230.$$

The *answer* is

$$y - 15 = -1.230(x - 17), \quad \text{hence} \quad y = 35.91 - 1.230x.$$

6.  $n = 9$ ,  $\sum x_i = 183$ ,  $\bar{x} = 20.33$ ,  $\sum y_i = 440$ ,  $\bar{y} = 48.89$ ,  $\sum x_i y_i = 7701$ ,  $(n - 1)s_x^2 = 8s_x^2 = 944$ . From (11) we thus obtain

$$k_1 = \frac{9 \cdot 7701 - 183 \cdot 440}{9 \cdot 944} = -1.32.$$

This gives the *answer*

$$y - 48.89 = -1.32(x - 20.33), \quad \text{hence} \quad y = 75.72 - 1.32x.$$

8. Equation (5) is

$$y - 1.875 = 0.067(x - 25); \quad \text{thus} \quad y = 0.2 + 0.067x.$$

10. Equation (5) is

$$y - 10 = 1.98(x - 5); \quad \text{thus} \quad y = 0.1 + 1.98x.$$

The spring modulus is  $1/1.98$ .

12.  $c = \pm 3.18$  from Table A9 with  $n - 2 = 3$  degrees of freedom (corresponding to  $2\frac{1}{2}\%$  and  $97\frac{1}{2}\%$ , by the symmetry of the  $t$ -distribution). From the sample we compute

$$4s_x^2 = 82\,000, \quad 4s_{xy} = 354\,100, \quad 4s_y^2 = 1\,530\,080.$$

From this and (7) we get

$$k_1 = \frac{354\,100}{82\,000} = 4.31829.$$

Also  $q_0 = 993$  and  $K = 0.2$ . The *answer* is

$$\text{CONF}_{0.95}\{4.1 \leq \kappa_1 \leq 4.5\}.$$

14. Multiplying out the square, we get three terms, hence three sums,

$$\begin{aligned} \sum (x_j - \bar{x})^2 &= \sum x_j^2 - 2\bar{x} \sum x_j + n\bar{x}^2 \\ &= \sum x_j^2 - \frac{2}{n} \sum x_i \sum x_j + n \left( \frac{1}{n} \sum x_j \right)^2 \end{aligned}$$

and the last of these three terms cancels half of the second term, giving the result.

### SOLUTIONS TO CHAP. 25 REVIEW QUESTIONS AND PROBLEMS, page 1092

22. From Table 25.1 in Sec. 25.3 we obtain  $k = 1.96 \cdot 4/\sqrt{400} = 0.392$  and

$$\text{CONF}_{0.95}\{52.6 \leq \mu \leq 53.4\}.$$

24.  $\bar{x} = 26.4$ ,  $k = 2.576 \cdot 2.2/\sqrt{5} = 2.534$  by Table 25.1, Sec. 25.3. This gives the *answer*

$$\text{CONF}_{0.99}\{23.86 \leq \mu \leq 28.94\}.$$

26.  $n - 1 = 3$  degrees of freedom,  $F(c_1) = 0.025$ ,  $c_1 = 0.22$ ,  $F(c_2) = 0.975$ ,  $c_2 = 9.35$  from Table A10 in App. 5; hence  $k_1 = 0.7/0.22 = 3.182$ ,  $k_2 = 0.7/9.35 = 0.075$  by Table 25.3 in Sec. 25.3. The *answer* is

$$\text{CONF}_{0.95}\{0.075 \leq \sigma^2 \leq 3.182\}.$$

28.  $k = 2.26 \cdot 0.157/\sqrt{10} = 0.112$ ;  $\text{CONF}_{0.95}\{4.25 \leq \mu \leq 4.49\}$

30.  $n = 41$  by trial and error, because  $F(c) = 0.975$  gives  $c = 2.02$  (Table A9 with 40 d.f.), so that  $L = 2k = 2sc/\sqrt{n} = 0.099$  by Table 25.2.

32. From Table A10 in App. 5 and Table 25.3 in Sec. 25.3 we obtain

$$\begin{aligned} c_1 &= \frac{1}{2}(\sqrt{253} - 2.58)^2 = 88.8, \\ c_2 &= \frac{1}{2}(\sqrt{253} + 2.58)^2 = 170.9, \end{aligned}$$

so that  $k_1 = 244/c_1 = 2.76$  and  $k_2 = 244/c_2 = 1.43$ . The *answer* is

$$\text{CONF}_{0.99}\{1.42 \leq \sigma^2 \leq 2.75\}.$$

34. The test is two-sided. We have  $\sigma^2/n = 0.025$ , as before. Table A8 gives

$$P(\bar{X} < c)_{15.0} = \Phi\left(\frac{c - 15.0}{\sqrt{0.025}}\right) = 0.975, \quad c = 15.31$$

and  $15.0 - 0.31 = 14.69$  as the left endpoint of the acceptance region. Now  $\bar{x} = 14.5 < 14.70$ , and we reject the hypothesis.

36. The test is right-sided. From Table A9 with  $n - 1 = 14$  degrees of freedom and

$$P(T > c)_{\mu_0} = 0.01, \quad \text{thus} \quad P(T \leq c)_{\mu_0} = 0.99$$

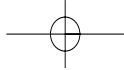

we get  $c = 2.62$ . From the sample we compute

$$t = \sqrt{15} \frac{36.2 - 35.0}{\sqrt{0.9}} = 4.90 > c$$

and reject the hypothesis.

- 38.** The hypothesis is  $\mu_0 = 1000$ , the alternative  $\mu \neq 1000$ . Because of the symmetry of the  $t$ -distribution, from Table A9 with 19 degrees of freedom we get for this two-sided test and the percentages 2.5% and 97.5% the critical values  $\pm 2.09$ . From the sample we compute

$$t = \sqrt{20}(991 - 1000)/8 = -5.03 < c = -2.09$$

and reject the hypothesis.

- 40.**  $2.58 \cdot \sqrt{0.00024}/\sqrt{2} = 0.028$ , LCL = 2.722, UCL = 2.778  
**42.**  $2.58\sqrt{0.0004}/\sqrt{2} = 0.036$ , UCL = 3.536, LCL = 3.464  
**44.**  $P(T \leq 3) = 6.8\%$  (Table A12). No.



