

Ninth Edition

PHYSICS

for Scientists and Engineers
with Modern Physics

SERWAY ■ **JEWETT**

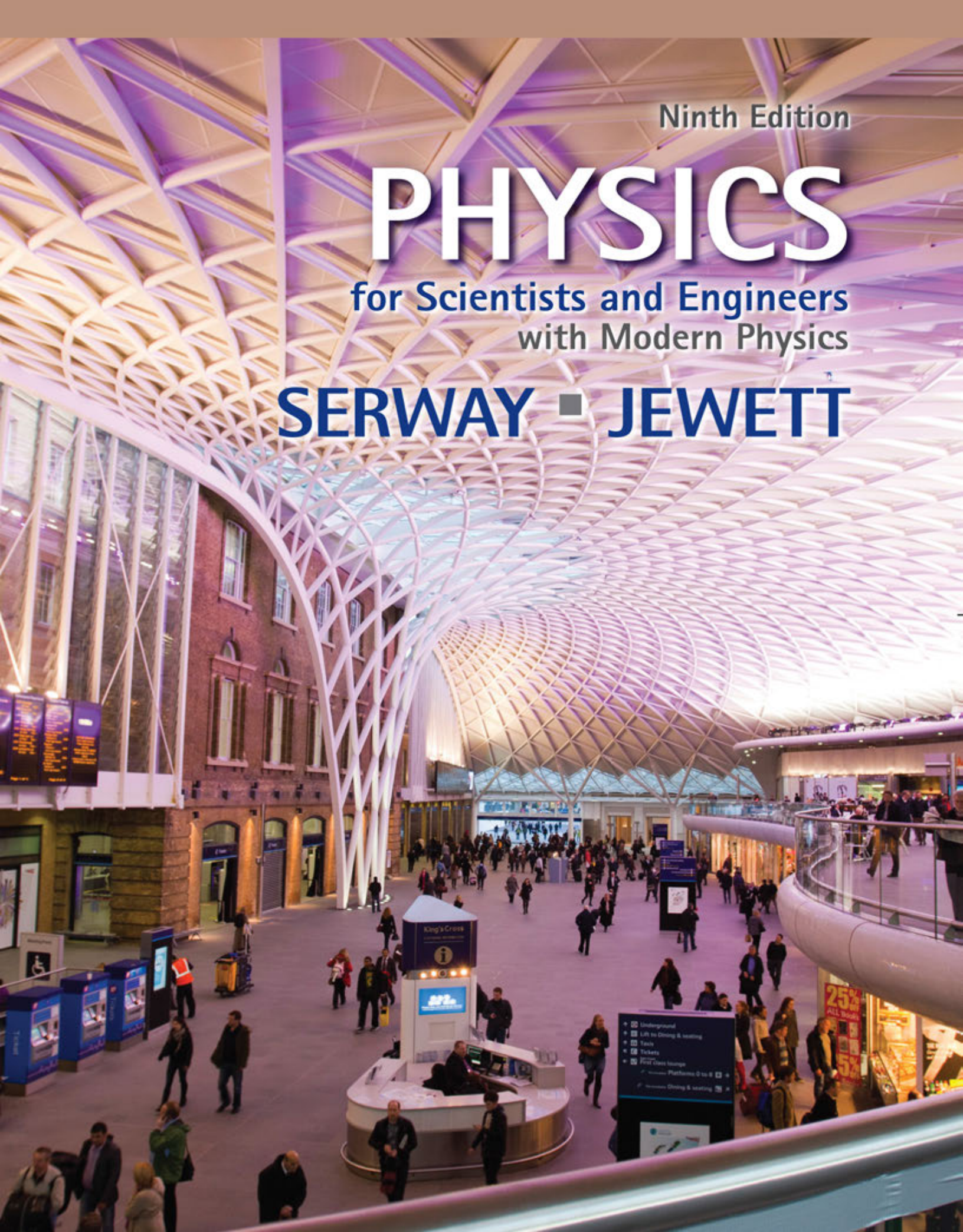



Pedagogical Color Chart

Mechanics and Thermodynamics

Displacement and position vectors 

Displacement and position component vectors 

Linear (\vec{v}) and angular ($\vec{\omega}$) velocity vectors 

Velocity component vectors 

Force vectors (\vec{F}) 

Force component vectors 

Acceleration vectors (\vec{a}) 

Acceleration component vectors 

Energy transfer arrows  W_{eng}

W_{eng}



Q_c



Q_h



Q_h

Process arrow 

Linear (\vec{p}) and angular (\vec{L}) momentum vectors 

Linear and angular momentum component vectors 

Torque vectors ($\vec{\tau}$) 

Torque component vectors 

Schematic linear or rotational motion directions 

Dimensional rotational arrow 

Enlargement arrow 

Springs 

Pulleys 

Electricity and Magnetism

Electric fields 

Electric field vectors 

Electric field component vectors 

Magnetic fields 

Magnetic field vectors 

Magnetic field component vectors 

Positive charges 

Negative charges 

Resistors 

Batteries and other DC power supplies 

Switches 

Capacitors 

Inductors (coils) 

Voltmeters 

Ammeters 

AC Sources 

Lightbulbs 

Ground symbol 

Current 

Light and Optics

Light ray 

Focal light ray 

Central light ray 

Converging lens 

Diverging lens 

Mirror 

Curved mirror 

Objects 

Images 

Some Physical Constants

Quantity	Symbol	Value ^a
Atomic mass unit	u	$1.660\,538\,782\,(83) \times 10^{-27}$ kg $931.494\,028\,(23)$ MeV/ c^2
Avogadro's number	N_A	$6.022\,141\,79\,(30) \times 10^{23}$ particles/mol
Bohr magneton	$\mu_B = \frac{e\hbar}{2m_e}$	$9.274\,009\,15\,(23) \times 10^{-24}$ J/T
Bohr radius	$a_0 = \frac{\hbar^2}{m_e e^2 k_e}$	$5.291\,772\,085\,9\,(36) \times 10^{-11}$ m
Boltzmann's constant	$k_B = \frac{R}{N_A}$	$1.380\,650\,4\,(24) \times 10^{-23}$ J/K
Compton wavelength	$\lambda_C = \frac{h}{m_e c}$	$2.426\,310\,217\,5\,(33) \times 10^{-12}$ m
Coulomb constant	$k_e = \frac{1}{4\pi\epsilon_0}$	$8.987\,551\,788 \dots \times 10^9$ N·m ² /C ² (exact)
Deuteron mass	m_d	$3.343\,583\,20\,(17) \times 10^{-27}$ kg $2.013\,553\,212\,724\,(78)$ u
Electron mass	m_e	$9.109\,382\,15\,(45) \times 10^{-31}$ kg $5.485\,799\,094\,3\,(23) \times 10^{-4}$ u $0.510\,998\,910\,(13)$ MeV/ c^2
Electron volt	eV	$1.602\,176\,487\,(40) \times 10^{-19}$ J
Elementary charge	e	$1.602\,176\,487\,(40) \times 10^{-19}$ C
Gas constant	R	$8.314\,472\,(15)$ J/mol·K
Gravitational constant	G	$6.674\,28\,(67) \times 10^{-11}$ N·m ² /kg ²
Neutron mass	m_n	$1.674\,927\,211\,(84) \times 10^{-27}$ kg $1.008\,664\,915\,97\,(43)$ u $939.565\,346\,(23)$ MeV/ c^2
Nuclear magneton	$\mu_n = \frac{e\hbar}{2m_p}$	$5.050\,783\,24\,(13) \times 10^{-27}$ J/T
Permeability of free space	μ_0	$4\pi \times 10^{-7}$ T·m/A (exact)
Permittivity of free space	$\epsilon_0 = \frac{1}{\mu_0 c^2}$	$8.854\,187\,817 \dots \times 10^{-12}$ C ² /N·m ² (exact)
Planck's constant	h	$6.626\,068\,96\,(33) \times 10^{-34}$ J·s
	$\hbar = \frac{h}{2\pi}$	$1.054\,571\,628\,(53) \times 10^{-34}$ J·s
Proton mass	m_p	$1.672\,621\,637\,(83) \times 10^{-27}$ kg $1.007\,276\,466\,77\,(10)$ u $938.272\,013\,(23)$ MeV/ c^2
Rydberg constant	R_H	$1.097\,373\,156\,852\,7\,(73) \times 10^7$ m ⁻¹
Speed of light in vacuum	c	$2.997\,924\,58 \times 10^8$ m/s (exact)

Note: These constants are the values recommended in 2006 by CODATA, based on a least-squares adjustment of data from different measurements. For a more complete list, see P. J. Mohr, B. N. Taylor, and D. B. Newell, "CODATA Recommended Values of the Fundamental Physical Constants: 2006." *Rev. Mod. Phys.* **80**:2, 633–730, 2008.

^aThe numbers in parentheses for the values represent the uncertainties of the last two digits.

Solar System Data

Body	Mass (kg)	Mean Radius (m)	Period (s)	Mean Distance from the Sun (m)
Mercury	3.30×10^{23}	2.44×10^6	7.60×10^6	5.79×10^{10}
Venus	4.87×10^{24}	6.05×10^6	1.94×10^7	1.08×10^{11}
Earth	5.97×10^{24}	6.37×10^6	3.156×10^7	1.496×10^{11}
Mars	6.42×10^{23}	3.39×10^6	5.94×10^7	2.28×10^{11}
Jupiter	1.90×10^{27}	6.99×10^7	3.74×10^8	7.78×10^{11}
Saturn	5.68×10^{26}	5.82×10^7	9.29×10^8	1.43×10^{12}
Uranus	8.68×10^{25}	2.54×10^7	2.65×10^9	2.87×10^{12}
Neptune	1.02×10^{26}	2.46×10^7	5.18×10^9	4.50×10^{12}
Pluto ^a	1.25×10^{22}	1.20×10^6	7.82×10^9	5.91×10^{12}
Moon	7.35×10^{22}	1.74×10^6	—	—
Sun	1.989×10^{30}	6.96×10^8	—	—

^aIn August 2006, the International Astronomical Union adopted a definition of a planet that separates Pluto from the other eight planets. Pluto is now defined as a “dwarf planet” (like the asteroid Ceres).

Physical Data Often Used

Average Earth–Moon distance	3.84×10^8 m
Average Earth–Sun distance	1.496×10^{11} m
Average radius of the Earth	6.37×10^6 m
Density of air (20°C and 1 atm)	1.20 kg/m ³
Density of air (0°C and 1 atm)	1.29 kg/m ³
Density of water (20°C and 1 atm)	1.00×10^3 kg/m ³
Free-fall acceleration	9.80 m/s ²
Mass of the Earth	5.97×10^{24} kg
Mass of the Moon	7.35×10^{22} kg
Mass of the Sun	1.99×10^{30} kg
Standard atmospheric pressure	1.013×10^5 Pa

Note: These values are the ones used in the text.

Some Prefixes for Powers of Ten

Power	Prefix	Abbreviation	Power	Prefix	Abbreviation
10^{-24}	yocto	y	10^1	deka	da
10^{-21}	zepto	z	10^2	hecto	h
10^{-18}	atto	a	10^3	kilo	k
10^{-15}	femto	f	10^6	mega	M
10^{-12}	pico	p	10^9	giga	G
10^{-9}	nano	n	10^{12}	tera	T
10^{-6}	micro	μ	10^{15}	peta	P
10^{-3}	milli	m	10^{18}	exa	E
10^{-2}	centi	c	10^{21}	zetta	Z
10^{-1}	deci	d	10^{24}	yotta	Y

Physics

for Scientists and Engineers
with Modern Physics

NINTH
EDITION

Raymond A. Serway

Emeritus, James Madison University

John W. Jewett, Jr.

*Emeritus, California State Polytechnic
University, Pomona*

With contributions from Vahé Perroomian,
University of California at Los Angeles

About the Cover

The cover shows a view inside the new railway departures concourse opened in March 2012 at the Kings Cross Station in London. The wall of the older structure (completed in 1852) is visible at the left. The sweeping shell-like roof is claimed by the architect to be the largest single-span station structure in Europe. Many principles of physics are required to design and construct such an open semicircular roof with a radius of 74 meters and containing over 2 000 triangular panels. Other principles of physics are necessary to develop the lighting design, optimize the acoustics, and integrate the new structure with existing infrastructure, historic buildings, and railway platforms.



 **BROOKS/COLE**
CENGAGE Learning®

© Ashley Cooper/Corbis

Brief Contents

PART 1 Mechanics 1

- 1 Physics and Measurement 2
- 2 Motion in One Dimension 21
- 3 Vectors 59
- 4 Motion in Two Dimensions 78
- 5 The Laws of Motion 111
- 6 Circular Motion and Other Applications of Newton's Laws 150
- 7 Energy of a System 177
- 8 Conservation of Energy 211
- 9 Linear Momentum and Collisions 247
- 10 Rotation of a Rigid Object About a Fixed Axis 293
- 11 Angular Momentum 335
- 12 Static Equilibrium and Elasticity 363
- 13 Universal Gravitation 388
- 14 Fluid Mechanics 417

PART 2 Oscillations and Mechanical Waves 449

- 15 Oscillatory Motion 450
- 16 Wave Motion 483
- 17 Sound Waves 507
- 18 Superposition and Standing Waves 533

PART 3 Thermodynamics 567

- 19 Temperature 568
- 20 The First Law of Thermodynamics 590
- 21 The Kinetic Theory of Gases 626
- 22 Heat Engines, Entropy, and the Second Law of Thermodynamics 653

PART 4 Electricity and Magnetism 689

- 23 Electric Fields 690
- 24 Gauss's Law 725
- 25 Electric Potential 746
- 26 Capacitance and Dielectrics 777
- 27 Current and Resistance 808
- 28 Direct-Current Circuits 833
- 29 Magnetic Fields 868
- 30 Sources of the Magnetic Field 904
- 31 Faraday's Law 935
- 32 Inductance 970
- 33 Alternating-Current Circuits 998
- 34 Electromagnetic Waves 1030

PART 5 Light and Optics 1057

- 35 The Nature of Light and the Principles of Ray Optics 1058
- 36 Image Formation 1090
- 37 Wave Optics 1134
- 38 Diffraction Patterns and Polarization 1160

PART 6 Modern Physics 1191

- 39 Relativity 1192
- 40 Introduction to Quantum Physics 1233
- 41 Quantum Mechanics 1267
- 42 Atomic Physics 1296
- 43 Molecules and Solids 1340
- 44 Nuclear Structure 1380
- 45 Applications of Nuclear Physics 1418
- 46 Particle Physics and Cosmology 1447

Contents

About the Authors viii

Preface ix

To the Student xxx

PART 1 Mechanics 1

1 Physics and Measurement 2

- 1.1 Standards of Length, Mass, and Time 3
- 1.2 Matter and Model Building 6
- 1.3 Dimensional Analysis 7
- 1.4 Conversion of Units 9
- 1.5 Estimates and Order-of-Magnitude Calculations 10
- 1.6 Significant Figures 11

2 Motion in One Dimension 21

- 2.1 Position, Velocity, and Speed 22
- 2.2 Instantaneous Velocity and Speed 25
- 2.3 Analysis Model: Particle Under Constant Velocity 28
- 2.4 Acceleration 31
- 2.5 Motion Diagrams 35
- 2.6 Analysis Model: Particle Under Constant Acceleration 36
- 2.7 Freely Falling Objects 40
- 2.8 Kinematic Equations Derived from Calculus 43

3 Vectors 59

- 3.1 Coordinate Systems 59
- 3.2 Vector and Scalar Quantities 61
- 3.3 Some Properties of Vectors 62
- 3.4 Components of a Vector and Unit Vectors 65

4 Motion in Two Dimensions 78

- 4.1 The Position, Velocity, and Acceleration Vectors 78
- 4.2 Two-Dimensional Motion with Constant Acceleration 81
- 4.3 Projectile Motion 84
- 4.4 Analysis Model: Particle in Uniform Circular Motion 91
- 4.5 Tangential and Radial Acceleration 94
- 4.6 Relative Velocity and Relative Acceleration 96

5 The Laws of Motion 111

- 5.1 The Concept of Force 111
- 5.2 Newton's First Law and Inertial Frames 113
- 5.3 Mass 114
- 5.4 Newton's Second Law 115
- 5.5 The Gravitational Force and Weight 117
- 5.6 Newton's Third Law 118
- 5.7 Analysis Models Using Newton's Second Law 120
- 5.8 Forces of Friction 130

6 Circular Motion and Other Applications of Newton's Laws 150

- 6.1 Extending the Particle in Uniform Circular Motion Model 150
- 6.2 Nonuniform Circular Motion 156
- 6.3 Motion in Accelerated Frames 158
- 6.4 Motion in the Presence of Resistive Forces 161

7 Energy of a System 177

- 7.1 Systems and Environments 178
- 7.2 Work Done by a Constant Force 178
- 7.3 The Scalar Product of Two Vectors 181
- 7.4 Work Done by a Varying Force 183
- 7.5 Kinetic Energy and the Work–Kinetic Energy Theorem 188
- 7.6 Potential Energy of a System 191
- 7.7 Conservative and Nonconservative Forces 196
- 7.8 Relationship Between Conservative Forces and Potential Energy 198
- 7.9 Energy Diagrams and Equilibrium of a System 199

8 Conservation of Energy 211

- 8.1 Analysis Model: Nonisolated System (Energy) 212
- 8.2 Analysis Model: Isolated System (Energy) 215
- 8.3 Situations Involving Kinetic Friction 222
- 8.4 Changes in Mechanical Energy for Nonconservative Forces 227
- 8.5 Power 232

9 Linear Momentum and Collisions 247

- 9.1 Linear Momentum 247
- 9.2 Analysis Model: Isolated System (Momentum) 250
- 9.3 Analysis Model: Nonisolated System (Momentum) 252
- 9.4 Collisions in One Dimension 256
- 9.5 Collisions in Two Dimensions 264
- 9.6 The Center of Mass 267
- 9.7 Systems of Many Particles 272
- 9.8 Deformable Systems 275
- 9.9 Rocket Propulsion 277

10 Rotation of a Rigid Object About a Fixed Axis 293

- 10.1 Angular Position, Velocity, and Acceleration 293
- 10.2 Analysis Model: Rigid Object Under Constant Angular Acceleration 296
- 10.3 Angular and Translational Quantities 298
- 10.4 Torque 300
- 10.5 Analysis Model: Rigid Object Under a Net Torque 302
- 10.6 Calculation of Moments of Inertia 307
- 10.7 Rotational Kinetic Energy 311
- 10.8 Energy Considerations in Rotational Motion 312
- 10.9 Rolling Motion of a Rigid Object 316

11 Angular Momentum 335

- 11.1 The Vector Product and Torque 335
- 11.2 Analysis Model: Nonisolated System (Angular Momentum) 338

- 11.3 Angular Momentum of a Rotating Rigid Object 342
- 11.4 Analysis Model: Isolated System (Angular Momentum) 345
- 11.5 The Motion of Gyroscopes and Tops 350

12 Static Equilibrium and Elasticity 363

- 12.1 Analysis Model: Rigid Object in Equilibrium 363
- 12.2 More on the Center of Gravity 365
- 12.3 Examples of Rigid Objects in Static Equilibrium 366
- 12.4 Elastic Properties of Solids 373

13 Universal Gravitation 388

- 13.1 Newton's Law of Universal Gravitation 389
- 13.2 Free-Fall Acceleration and the Gravitational Force 391
- 13.3 Analysis Model: Particle in a Field (Gravitational) 392
- 13.4 Kepler's Laws and the Motion of Planets 394
- 13.5 Gravitational Potential Energy 400
- 13.6 Energy Considerations in Planetary and Satellite Motion 402

14 Fluid Mechanics 417

- 14.1 Pressure 417
- 14.2 Variation of Pressure with Depth 419
- 14.3 Pressure Measurements 423
- 14.4 Buoyant Forces and Archimedes's Principle 423
- 14.5 Fluid Dynamics 427
- 14.6 Bernoulli's Equation 430
- 14.7 Other Applications of Fluid Dynamics 433

PART 2 Oscillations and Mechanical Waves 449

15 Oscillatory Motion 450

- 15.1 Motion of an Object Attached to a Spring 450
- 15.2 Analysis Model: Particle in Simple Harmonic Motion 452
- 15.3 Energy of the Simple Harmonic Oscillator 458
- 15.4 Comparing Simple Harmonic Motion with Uniform Circular Motion 462
- 15.5 The Pendulum 464
- 15.6 Damped Oscillations 468
- 15.7 Forced Oscillations 469

16 Wave Motion 483

- 16.1 Propagation of a Disturbance 484
- 16.2 Analysis Model: Traveling Wave 487
- 16.3 The Speed of Waves on Strings 491
- 16.4 Reflection and Transmission 494
- 16.5 Rate of Energy Transfer by Sinusoidal Waves on Strings 495
- 16.6 The Linear Wave Equation 497

17 Sound Waves 507

- 17.1 Pressure Variations in Sound Waves 508
- 17.2 Speed of Sound Waves 510
- 17.3 Intensity of Periodic Sound Waves 512
- 17.4 The Doppler Effect 517

18 Superposition and Standing Waves 533

- 18.1 Analysis Model: Waves in Interference 534
- 18.2 Standing Waves 538
- 18.3 Analysis Model: Waves Under Boundary Conditions 541
- 18.4 Resonance 546
- 18.5 Standing Waves in Air Columns 546
- 18.6 Standing Waves in Rods and Membranes 550
- 18.7 Beats: Interference in Time 550
- 18.8 Nonsinusoidal Wave Patterns 553

PART 3 Thermodynamics 567

19 Temperature 568

- 19.1 Temperature and the Zeroth Law of Thermodynamics 568
- 19.2 Thermometers and the Celsius Temperature Scale 570
- 19.3 The Constant-Volume Gas Thermometer and the Absolute Temperature Scale 571
- 19.4 Thermal Expansion of Solids and Liquids 573
- 19.5 Macroscopic Description of an Ideal Gas 578

20 The First Law of Thermodynamics 590

- 20.1 Heat and Internal Energy 590
- 20.2 Specific Heat and Calorimetry 593
- 20.3 Latent Heat 597
- 20.4 Work and Heat in Thermodynamic Processes 601
- 20.5 The First Law of Thermodynamics 603
- 20.6 Some Applications of the First Law of Thermodynamics 604
- 20.7 Energy Transfer Mechanisms in Thermal Processes 608

21 The Kinetic Theory of Gases 626

- 21.1 Molecular Model of an Ideal Gas 627
- 21.2 Molar Specific Heat of an Ideal Gas 631
- 21.3 The Equipartition of Energy 635
- 21.4 Adiabatic Processes for an Ideal Gas 637
- 21.5 Distribution of Molecular Speeds 639

22 Heat Engines, Entropy, and the Second Law of Thermodynamics 653

- 22.1 Heat Engines and the Second Law of Thermodynamics 654
- 22.2 Heat Pumps and Refrigerators 656
- 22.3 Reversible and Irreversible Processes 659
- 22.4 The Carnot Engine 660
- 22.5 Gasoline and Diesel Engines 665
- 22.6 Entropy 667
- 22.7 Changes in Entropy for Thermodynamic Systems 671
- 22.8 Entropy and the Second Law 676

PART 4 Electricity and Magnetism 689

23 Electric Fields 690

- 23.1 Properties of Electric Charges 690
- 23.2 Charging Objects by Induction 692
- 23.3 Coulomb's Law 694
- 23.4 Analysis Model: Particle in a Field (Electric) 699
- 23.5 Electric Field of a Continuous Charge Distribution 704
- 23.6 Electric Field Lines 708
- 23.7 Motion of a Charged Particle in a Uniform Electric Field 710

24 Gauss's Law 725

- 24.1 Electric Flux 725
- 24.2 Gauss's Law 728
- 24.3 Application of Gauss's Law to Various Charge Distributions 731
- 24.4 Conductors in Electrostatic Equilibrium 735

25 Electric Potential 746

- 25.1 Electric Potential and Potential Difference 746
- 25.2 Potential Difference in a Uniform Electric Field 748

- 25.3 Electric Potential and Potential Energy Due to Point Charges 752
- 25.4 Obtaining the Value of the Electric Field from the Electric Potential 755
- 25.5 Electric Potential Due to Continuous Charge Distributions 756
- 25.6 Electric Potential Due to a Charged Conductor 761
- 25.7 The Millikan Oil-Drop Experiment 764
- 25.8 Applications of Electrostatics 765

26 Capacitance and Dielectrics 777

- 26.1 Definition of Capacitance 777
- 26.2 Calculating Capacitance 779
- 26.3 Combinations of Capacitors 782
- 26.4 Energy Stored in a Charged Capacitor 786
- 26.5 Capacitors with Dielectrics 790
- 26.6 Electric Dipole in an Electric Field 793
- 26.7 An Atomic Description of Dielectrics 795

27 Current and Resistance 808

- 27.1 Electric Current 808
- 27.2 Resistance 811
- 27.3 A Model for Electrical Conduction 816
- 27.4 Resistance and Temperature 819
- 27.5 Superconductors 819
- 27.6 Electrical Power 820

28 Direct-Current Circuits 833

- 28.1 Electromotive Force 833
- 28.2 Resistors in Series and Parallel 836
- 28.3 Kirchhoff's Rules 843
- 28.4 RC Circuits 846
- 28.5 Household Wiring and Electrical Safety 852

29 Magnetic Fields 868

- 29.1 Analysis Model: Particle in a Field (Magnetic) 869
- 29.2 Motion of a Charged Particle in a Uniform Magnetic Field 874
- 29.3 Applications Involving Charged Particles Moving in a Magnetic Field 879
- 29.4 Magnetic Force Acting on a Current-Carrying Conductor 882
- 29.5 Torque on a Current Loop in a Uniform Magnetic Field 885
- 29.6 The Hall Effect 890

30 Sources of the Magnetic Field 904

- 30.1 The Biot-Savart Law 904
- 30.2 The Magnetic Force Between Two Parallel Conductors 909
- 30.3 Ampère's Law 911
- 30.4 The Magnetic Field of a Solenoid 915
- 30.5 Gauss's Law in Magnetism 916
- 30.6 Magnetism in Matter 919

31 Faraday's Law 935

- 31.1 Faraday's Law of Induction 935
- 31.2 Motional emf 939
- 31.3 Lenz's Law 944
- 31.4 Induced emf and Electric Fields 947
- 31.5 Generators and Motors 949
- 31.6 Eddy Currents 953

32 Inductance 970

- 32.1 Self-Induction and Inductance 970
- 32.2 RL Circuits 972
- 32.3 Energy in a Magnetic Field 976
- 32.4 Mutual Inductance 978
- 32.5 Oscillations in an LC Circuit 980
- 32.6 The RLC Circuit 984

33 Alternating-Current Circuits 998

- 33.1 AC Sources 998
- 33.2 Resistors in an AC Circuit 999
- 33.3 Inductors in an AC Circuit 1002
- 33.4 Capacitors in an AC Circuit 1004
- 33.5 The RLC Series Circuit 1007
- 33.6 Power in an AC Circuit 1011
- 33.7 Resonance in a Series RLC Circuit 1013
- 33.8 The Transformer and Power Transmission 1015
- 33.9 Rectifiers and Filters 1018

34 Electromagnetic Waves 1030

- 34.1 Displacement Current and the General Form of Ampère's Law 1031
- 34.2 Maxwell's Equations and Hertz's Discoveries 1033
- 34.3 Plane Electromagnetic Waves 1035
- 34.4 Energy Carried by Electromagnetic Waves 1039
- 34.5 Momentum and Radiation Pressure 1042
- 34.6 Production of Electromagnetic Waves by an Antenna 1044
- 34.7 The Spectrum of Electromagnetic Waves 1045

PART 5

Light and Optics 1057

35 The Nature of Light and the Principles of Ray Optics 1058

- 35.1 The Nature of Light 1058
- 35.2 Measurements of the Speed of Light 1059
- 35.3 The Ray Approximation in Ray Optics 1061
- 35.4 Analysis Model: Wave Under Reflection 1061
- 35.5 Analysis Model: Wave Under Refraction 1065
- 35.6 Huygens's Principle 1071
- 35.7 Dispersion 1072
- 35.8 Total Internal Reflection 1074

36 Image Formation 1090

- 36.1 Images Formed by Flat Mirrors 1090
- 36.2 Images Formed by Spherical Mirrors 1093
- 36.3 Images Formed by Refraction 1100
- 36.4 Images Formed by Thin Lenses 1104
- 36.5 Lens Aberrations 1112
- 36.6 The Camera 1113
- 36.7 The Eye 1115
- 36.8 The Simple Magnifier 1118
- 36.9 The Compound Microscope 1119
- 36.10 The Telescope 1120

37 Wave Optics 1134

- 37.1 Young's Double-Slit Experiment 1134
- 37.2 Analysis Model: Waves in Interference 1137
- 37.3 Intensity Distribution of the Double-Slit Interference Pattern 1140
- 37.4 Change of Phase Due to Reflection 1143
- 37.5 Interference in Thin Films 1144
- 37.6 The Michelson Interferometer 1147

38 Diffraction Patterns and Polarization 1160

- 38.1 Introduction to Diffraction Patterns 1160
- 38.2 Diffraction Patterns from Narrow Slits 1161
- 38.3 Resolution of Single-Slit and Circular Apertures 1166
- 38.4 The Diffraction Grating 1169
- 38.5 Diffraction of X-Rays by Crystals 1174
- 38.6 Polarization of Light Waves 1175

PART 6

Modern Physics 1191

39 Relativity 1192

- 39.1 The Principle of Galilean Relativity 1193
- 39.2 The Michelson–Morley Experiment 1196
- 39.3 Einstein's Principle of Relativity 1198
- 39.4 Consequences of the Special Theory of Relativity 1199
- 39.5 The Lorentz Transformation Equations 1210
- 39.6 The Lorentz Velocity Transformation Equations 1212
- 39.7 Relativistic Linear Momentum 1214
- 39.8 Relativistic Energy 1216
- 39.9 The General Theory of Relativity 1220

40 Introduction to Quantum Physics 1233

- 40.1 Blackbody Radiation and Planck's Hypothesis 1234
- 40.2 The Photoelectric Effect 1240
- 40.3 The Compton Effect 1246
- 40.4 The Nature of Electromagnetic Waves 1249
- 40.5 The Wave Properties of Particles 1249
- 40.6 A New Model: The Quantum Particle 1252
- 40.7 The Double-Slit Experiment Revisited 1255
- 40.8 The Uncertainty Principle 1256

41 Quantum Mechanics 1267

- 41.1 The Wave Function 1267
- 41.2 Analysis Model: Quantum Particle Under Boundary Conditions 1271
- 41.3 The Schrödinger Equation 1277
- 41.4 A Particle in a Well of Finite Height 1279
- 41.5 Tunneling Through a Potential Energy Barrier 1281
- 41.6 Applications of Tunneling 1282
- 41.7 The Simple Harmonic Oscillator 1286

42 Atomic Physics 1296

- 42.1 Atomic Spectra of Gases 1297
- 42.2 Early Models of the Atom 1299
- 42.3 Bohr's Model of the Hydrogen Atom 1300
- 42.4 The Quantum Model of the Hydrogen Atom 1306
- 42.5 The Wave Functions for Hydrogen 1308
- 42.6 Physical Interpretation of the Quantum Numbers 1311
- 42.7 The Exclusion Principle and the Periodic Table 1318
- 42.8 More on Atomic Spectra: Visible and X-Ray 1322
- 42.9 Spontaneous and Stimulated Transitions 1325
- 42.10 Lasers 1326

43 Molecules and Solids 1340

- 43.1 Molecular Bonds 1341
- 43.2 Energy States and Spectra of Molecules 1344
- 43.3 Bonding in Solids 1352
- 43.4 Free-Electron Theory of Metals 1355
- 43.5 Band Theory of Solids 1359
- 43.6 Electrical Conduction in Metals, Insulators, and Semiconductors 1361
- 43.7 Semiconductor Devices 1364
- 43.8 Superconductivity 1370

44 Nuclear Structure 1380

- 44.1 Some Properties of Nuclei 1381
- 44.2 Nuclear Binding Energy 1386
- 44.3 Nuclear Models 1387
- 44.4 Radioactivity 1390

- 44.5 The Decay Processes 1394
- 44.6 Natural Radioactivity 1404
- 44.7 Nuclear Reactions 1405
- 44.8 Nuclear Magnetic Resonance and Magnetic Resonance Imaging 1406

45 Applications of Nuclear Physics 1418

- 45.1 Interactions Involving Neutrons 1418
- 45.2 Nuclear Fission 1419
- 45.3 Nuclear Reactors 1421
- 45.4 Nuclear Fusion 1425
- 45.5 Radiation Damage 1432
- 45.6 Uses of Radiation 1434

46 Particle Physics and Cosmology 1447

- 46.1 The Fundamental Forces in Nature 1448
- 46.2 Positrons and Other Antiparticles 1449
- 46.3 Mesons and the Beginning of Particle Physics 1451
- 46.4 Classification of Particles 1454
- 46.5 Conservation Laws 1455
- 46.6 Strange Particles and Strangeness 1459
- 46.7 Finding Patterns in the Particles 1460
- 46.8 Quarks 1462
- 46.9 Multicolored Quarks 1465
- 46.10 The Standard Model 1467
- 46.11 The Cosmic Connection 1469
- 46.12 Problems and Perspectives 1474

Appendices

A Tables A-1

- A.1 Conversion Factors A-1
- A.2 Symbols, Dimensions, and Units of Physical Quantities A-2

B Mathematics Review A-4

- B.1 Scientific Notation A-4
- B.2 Algebra A-5
- B.3 Geometry A-10
- B.4 Trigonometry A-11
- B.5 Series Expansions A-13
- B.6 Differential Calculus A-13
- B.7 Integral Calculus A-16
- B.8 Propagation of Uncertainty A-20

C Periodic Table of the Elements A-22

D SI Units A-24

- D.1 SI Units A-24
- D.2 Some Derived SI Units A-24

Answers to Quick Quizzes and Odd-Numbered Problems A-25

Index I-1

- 23.1 Properties of Electric Charges
- 23.2 Charging Objects by Induction
- 23.3 Coulomb's Law
- 23.4 Analysis Model: Particle in a Field (Electric)
- 23.5 Electric Field of a Continuous Charge Distribution
- 23.6 Electric Field Lines
- 23.7 Motion of a Charged Particle in a Uniform Electric Field



This young woman is enjoying the effects of electrically charging her body. Each individual hair on her head becomes charged and exerts a repulsive force on the other hairs, resulting in the "stand-up" hairdo seen here. (Ted Kinsman / Photo Researchers, Inc.)

In this chapter, we begin the study of electromagnetism. The first link that we will make to our previous study is through the concept of *force*. The electromagnetic force between charged particles is one of the fundamental forces of nature. We begin by describing some basic properties of one manifestation of the electromagnetic force, the electric force. We then discuss Coulomb's law, which is the fundamental law governing the electric force between any two charged particles. Next, we introduce the concept of an electric field associated with a charge distribution and describe its effect on other charged particles. We then show how to use Coulomb's law to calculate the electric field for a given charge distribution. The chapter concludes with a discussion of the motion of a charged particle in a uniform electric field.

The second link between electromagnetism and our previous study is through the concept of *energy*. We will discuss that connection in Chapter 25.

23.1 Properties of Electric Charges

A number of simple experiments demonstrate the existence of electric forces. For example, after rubbing a balloon on your hair on a dry day, you will find that the balloon attracts bits of paper. The attractive force is often strong enough to suspend the paper from the balloon.

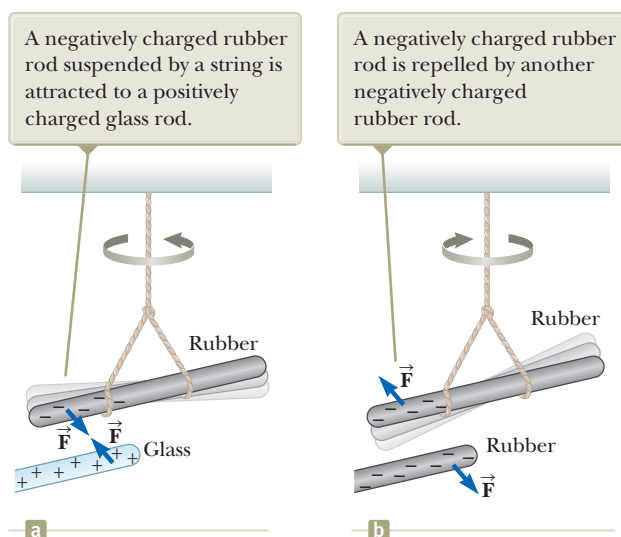

Figure 23.1 The electric force between (a) oppositely charged objects and (b) like-charged objects.

When materials behave in this way, they are said to be *electrified* or to have become **electrically charged**. You can easily electrify your body by vigorously rubbing your shoes on a wool rug. Evidence of the electric charge on your body can be detected by lightly touching (and startling) a friend. Under the right conditions, you will see a spark when you touch and both of you will feel a slight tingle. (Experiments such as these work best on a dry day because an excessive amount of moisture in the air can cause any charge you build up to “leak” from your body to the Earth.)

In a series of simple experiments, it was found that there are two kinds of electric charges, which were given the names **positive** and **negative** by Benjamin Franklin (1706–1790). Electrons are identified as having negative charge, and protons are positively charged. To verify that there are two types of charge, suppose a hard rubber rod that has been rubbed on fur is suspended by a string as shown in Figure 23.1. When a glass rod that has been rubbed on silk is brought near the rubber rod, the two attract each other (Fig. 23.1a). On the other hand, if two charged rubber rods (or two charged glass rods) are brought near each other as shown in Figure 23.1b, the two repel each other. This observation shows that the rubber and glass have two different types of charge on them. On the basis of these observations, we conclude that **charges of the same sign repel one another and charges with opposite signs attract one another**.

Using the convention suggested by Franklin, the electric charge on the glass rod is called positive and that on the rubber rod is called negative. Therefore, any charged object attracted to a charged rubber rod (or repelled by a charged glass rod) must have a positive charge, and any charged object repelled by a charged rubber rod (or attracted to a charged glass rod) must have a negative charge.

Another important aspect of electricity that arises from experimental observations is that **electric charge is always conserved** in an isolated system. That is, when one object is rubbed against another, charge is not created in the process. The electrified state is due to a *transfer* of charge from one object to the other. One object gains some amount of negative charge while the other gains an equal amount of positive charge. For example, when a glass rod is rubbed on silk as in Figure 23.2, the silk obtains a negative charge equal in magnitude to the positive charge on the glass rod. We now know from our understanding of atomic structure that electrons are transferred in the rubbing process from the glass to the silk. Similarly, when rubber is rubbed on fur, electrons are transferred from the fur to the rubber, giving the rubber a net negative charge and the fur a net positive charge. This process works because neutral, uncharged matter contains as many positive charges (protons within atomic nuclei)

Because of conservation of charge, each electron adds negative charge to the silk and an equal positive charge is left on the glass rod.

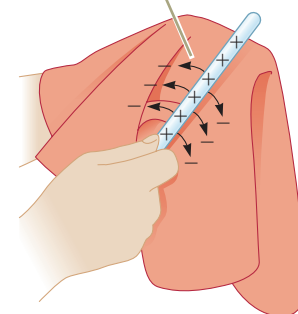

Figure 23.2 When a glass rod is rubbed with silk, electrons are transferred from the glass to the silk.

◀ **Electric charge is conserved**

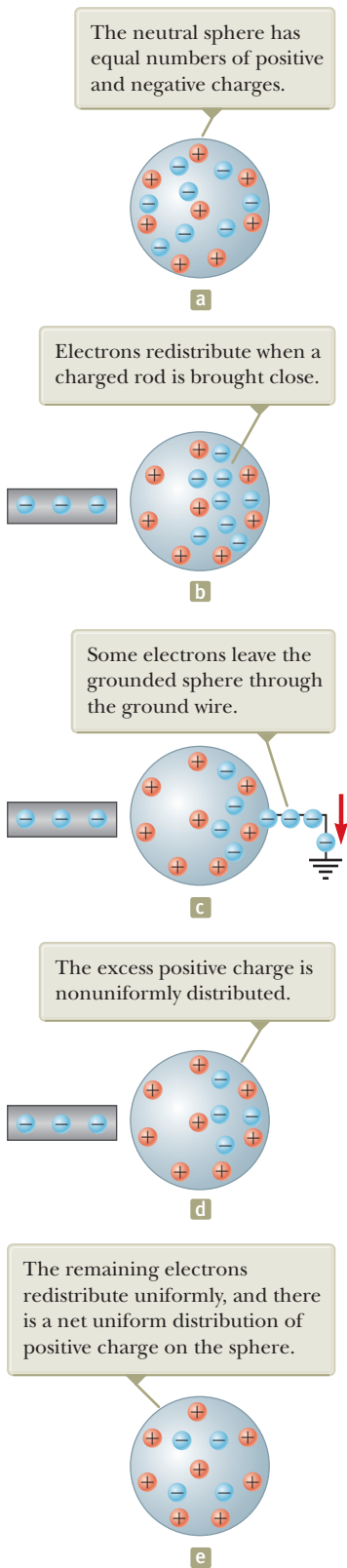

Figure 23.3 Charging a metallic object by *induction*. (a) A neutral metallic sphere. (b) A charged rubber rod is placed near the sphere. (c) The sphere is grounded. (d) The ground connection is removed. (e) The rod is removed.

as negative charges (electrons). Conservation of electric charge for an isolated system is like conservation of energy, momentum, and angular momentum, but we don't identify an analysis model for this conservation principle because it is not used often enough in the mathematical solution to problems.

In 1909, Robert Millikan (1868–1953) discovered that electric charge always occurs as integral multiples of a fundamental amount of charge e (see Section 25.7). In modern terms, the electric charge q is said to be **quantized**, where q is the standard symbol used for charge as a variable. That is, electric charge exists as discrete “packets,” and we can write $q = \pm Ne$, where N is some integer. Other experiments in the same period showed that the electron has a charge $-e$ and the proton has a charge of equal magnitude but opposite sign $+e$. Some particles, such as the neutron, have no charge.

Quick Quiz 23.1 Three objects are brought close to each other, two at a time. When objects A and B are brought together, they repel. When objects B and C are brought together, they also repel. Which of the following are true? (a) Objects A and C possess charges of the same sign. (b) Objects A and C possess charges of opposite sign. (c) All three objects possess charges of the same sign. (d) One object is neutral. (e) Additional experiments must be performed to determine the signs of the charges.

23.2 Charging Objects by Induction

It is convenient to classify materials in terms of the ability of electrons to move through the material:

Electrical **conductors** are materials in which some of the electrons are free electrons¹ that are not bound to atoms and can move relatively freely through the material; electrical **insulators** are materials in which all electrons are bound to atoms and cannot move freely through the material.

Materials such as glass, rubber, and dry wood fall into the category of electrical insulators. When such materials are charged by rubbing, only the area rubbed becomes charged and the charged particles are unable to move to other regions of the material.

In contrast, materials such as copper, aluminum, and silver are good electrical conductors. When such materials are charged in some small region, the charge readily distributes itself over the entire surface of the material.

Semiconductors are a third class of materials, and their electrical properties are somewhere between those of insulators and those of conductors. Silicon and germanium are well-known examples of semiconductors commonly used in the fabrication of a variety of electronic chips used in computers, cellular telephones, and home theater systems. The electrical properties of semiconductors can be changed over many orders of magnitude by the addition of controlled amounts of certain atoms to the materials.

To understand how to charge a conductor by a process known as **induction**, consider a neutral (uncharged) conducting sphere insulated from the ground as shown in Figure 23.3a. There are an equal number of electrons and protons in the sphere if the charge on the sphere is exactly zero. When a negatively charged rubber rod is brought near the sphere, electrons in the region nearest the rod experience a repulsive force and migrate to the opposite side of the sphere. This migration leaves

¹A metal atom contains one or more outer electrons, which are weakly bound to the nucleus. When many atoms combine to form a metal, the *free electrons* are these outer electrons, which are not bound to any one atom. These electrons move about the metal in a manner similar to that of gas molecules moving in a container.

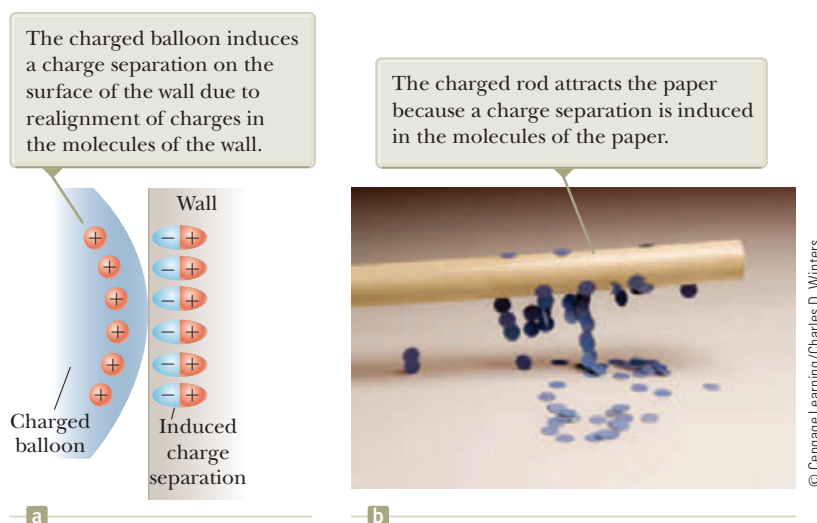

Figure 23.4 (a) A charged balloon is brought near an insulating wall. (b) A charged rod is brought close to bits of paper.

the side of the sphere near the rod with an effective positive charge because of the diminished number of electrons as in Figure 23.3b. (The left side of the sphere in Figure 23.3b is positively charged *as if* positive charges moved into this region, but remember that only electrons are free to move.) This process occurs even if the rod never actually touches the sphere. If the same experiment is performed with a conducting wire connected from the sphere to the Earth (Fig. 23.3c), some of the electrons in the conductor are so strongly repelled by the presence of the negative charge in the rod that they move out of the sphere through the wire and into the Earth. The symbol \equiv at the end of the wire in Figure 23.3c indicates that the wire is connected to **ground**, which means a reservoir, such as the Earth, that can accept or provide electrons freely with negligible effect on its electrical characteristics. If the wire to ground is then removed (Fig. 23.3d), the conducting sphere contains an excess of *induced* positive charge because it has fewer electrons than it needs to cancel out the positive charge of the protons. When the rubber rod is removed from the vicinity of the sphere (Fig. 23.3e), this induced positive charge remains on the ungrounded sphere. Notice that the rubber rod loses none of its negative charge during this process.

Charging an object by induction requires no contact with the object inducing the charge. That is in contrast to charging an object by rubbing (that is, by *conduction*), which does require contact between the two objects.

A process similar to induction in conductors takes place in insulators. In most neutral molecules, the center of positive charge coincides with the center of negative charge. In the presence of a charged object, however, these centers inside each molecule in an insulator may shift slightly, resulting in more positive charge on one side of the molecule than on the other. This realignment of charge within individual molecules produces a layer of charge on the surface of the insulator as shown in Figure 23.4a. The proximity of the positive charges on the surface of the object and the negative charges on the surface of the insulator results in an attractive force between the object and the insulator. Your knowledge of induction in insulators should help you explain why a charged rod attracts bits of electrically neutral paper as shown in Figure 23.4b.

- Quick Quiz 23.2** Three objects are brought close to one another, two at a time. When objects A and B are brought together, they attract. When objects B and C are brought together, they repel. Which of the following are necessarily true? (a) Objects A and C possess charges of the same sign. (b) Objects A and C possess charges of opposite sign. (c) All three objects possess charges of the same sign. (d) One object is neutral. (e) Additional experiments must be performed to determine information about the charges on the objects.

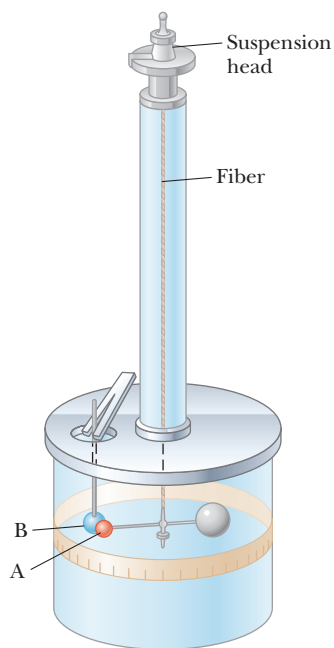

Figure 23.5 Coulomb's balance, used to establish the inverse-square law for the electric force.

23.3 Coulomb's Law

Charles Coulomb measured the magnitudes of the electric forces between charged objects using the torsion balance, which he invented (Fig. 23.5). The operating principle of the torsion balance is the same as that of the apparatus used by Cavendish to measure the density of the Earth (see Section 13.1), with the electrically neutral spheres replaced by charged ones. The electric force between charged spheres A and B in Figure 23.5 causes the spheres to either attract or repel each other, and the resulting motion causes the suspended fiber to twist. Because the restoring torque of the twisted fiber is proportional to the angle through which the fiber rotates, a measurement of this angle provides a quantitative measure of the electric force of attraction or repulsion. Once the spheres are charged by rubbing, the electric force between them is very large compared with the gravitational attraction, and so the gravitational force can be neglected.

From Coulomb's experiments, we can generalize the properties of the **electric force** (sometimes called the *electrostatic force*) between two stationary charged particles. We use the term **point charge** to refer to a charged particle of zero size. The electrical behavior of electrons and protons is very well described by modeling them as point charges. From experimental observations, we find that the magnitude of the electric force (sometimes called the *Coulomb force*) between two point charges is given by **Coulomb's law**.

Coulomb's law ▶

$$F_e = k_e \frac{|q_1||q_2|}{r^2} \quad (23.1)$$

where k_e is a constant called the **Coulomb constant**. In his experiments, Coulomb was able to show that the value of the exponent of r was 2 to within an uncertainty of a few percent. Modern experiments have shown that the exponent is 2 to within an uncertainty of a few parts in 10^{16} . Experiments also show that the electric force, like the gravitational force, is conservative.

The value of the Coulomb constant depends on the choice of units. The SI unit of charge is the **coulomb** (C). The Coulomb constant k_e in SI units has the value

Coulomb constant ▶

$$k_e = 8.987\,6 \times 10^9 \text{ N} \cdot \text{m}^2/\text{C}^2 \quad (23.2)$$

This constant is also written in the form

$$k_e = \frac{1}{4\pi\epsilon_0} \quad (23.3)$$

where the constant ϵ_0 (Greek letter epsilon) is known as the **permittivity of free space** and has the value

$$\epsilon_0 = 8.854\,2 \times 10^{-12} \text{ C}^2/\text{N} \cdot \text{m}^2 \quad (23.4)$$

The smallest unit of free charge e known in nature,² the charge on an electron ($-e$) or a proton ($+e$), has a magnitude

$$e = 1.602\,18 \times 10^{-19} \text{ C} \quad (23.5)$$

Therefore, 1 C of charge is approximately equal to the charge of 6.24×10^{18} electrons or protons. This number is very small when compared with the number of free electrons in 1 cm^3 of copper, which is on the order of 10^{23} . Nevertheless, 1 C is a substantial amount of charge. In typical experiments in which a rubber or glass rod is charged by friction, a net charge on the order of 10^{-6} C is obtained. In other

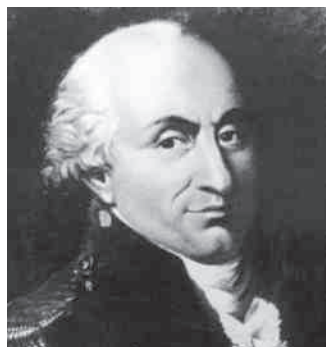

© INTERFOTO/Alamy

Charles Coulomb

French physicist (1736–1806)

Coulomb's major contributions to science were in the areas of electrostatics and magnetism. During his lifetime, he also investigated the strengths of materials, thereby contributing to the field of structural mechanics. In ergonomics, his research provided an understanding of the ways in which people and animals can best do work.

²No unit of charge smaller than e has been detected on a free particle; current theories, however, propose the existence of particles called *quarks* having charges $-e/3$ and $2e/3$. Although there is considerable experimental evidence for such particles inside nuclear matter, *free* quarks have never been detected. We discuss other properties of quarks in Chapter 46.

Table 23.1 Charge and Mass of the Electron, Proton, and Neutron

Particle	Charge (C)	Mass (kg)
Electron (e)	$-1.602\,176\,5 \times 10^{-19}$	$9.109\,4 \times 10^{-31}$
Proton (p)	$+1.602\,176\,5 \times 10^{-19}$	$1.672\,62 \times 10^{-27}$
Neutron (n)	0	$1.674\,93 \times 10^{-27}$

words, only a very small fraction of the total available charge is transferred between the rod and the rubbing material.

The charges and masses of the electron, proton, and neutron are given in Table 23.1. Notice that the electron and proton are identical in the magnitude of their charge but vastly different in mass. On the other hand, the proton and neutron are similar in mass but vastly different in charge. Chapter 46 will help us understand these interesting properties.

Example 23.1 The Hydrogen Atom

The electron and proton of a hydrogen atom are separated (on the average) by a distance of approximately 5.3×10^{-11} m. Find the magnitudes of the electric force and the gravitational force between the two particles.

SOLUTION

Conceptualize Think about the two particles separated by the very small distance given in the problem statement. In Chapter 13, we mentioned that the gravitational force between an electron and a proton is very small compared to the electric force between them, so we expect this to be the case with the results of this example.

Categorize The electric and gravitational forces will be evaluated from universal force laws, so we categorize this example as a substitution problem.

Use Coulomb's law to find the magnitude of the electric force:

$$F_e = k_e \frac{|e||-e|}{r^2} = (8.988 \times 10^9 \text{ N} \cdot \text{m}^2/\text{C}^2) \frac{(1.60 \times 10^{-19} \text{ C})^2}{(5.3 \times 10^{-11} \text{ m})^2}$$

$$= 8.2 \times 10^{-8} \text{ N}$$

Use Newton's law of universal gravitation and Table 23.1 (for the particle masses) to find the magnitude of the gravitational force:

$$F_g = G \frac{m_e m_p}{r^2}$$

$$= (6.674 \times 10^{-11} \text{ N} \cdot \text{m}^2/\text{kg}^2) \frac{(9.11 \times 10^{-31} \text{ kg})(1.67 \times 10^{-27} \text{ kg})}{(5.3 \times 10^{-11} \text{ m})^2}$$

$$= 3.6 \times 10^{-47} \text{ N}$$

The ratio $F_e/F_g \approx 2 \times 10^{39}$. Therefore, the gravitational force between charged atomic particles is negligible when compared with the electric force. Notice the similar forms of Newton's law of universal gravitation and Coulomb's law of electric forces. Other than the magnitude of the forces between elementary particles, what is a fundamental difference between the two forces?

When dealing with Coulomb's law, remember that force is a vector quantity and must be treated accordingly. Coulomb's law expressed in vector form for the electric force exerted by a charge q_1 on a second charge q_2 , written $\vec{\mathbf{F}}_{12}$, is

$$\vec{\mathbf{F}}_{12} = k_e \frac{q_1 q_2}{r^2} \hat{\mathbf{r}}_{12} \quad (23.6)$$

◀ Vector form of Coulomb's law

where $\hat{\mathbf{r}}_{12}$ is a unit vector directed from q_1 toward q_2 as shown in Figure 23.6a (page 696). Because the electric force obeys Newton's third law, the electric force exerted by q_2 on q_1 is equal in magnitude to the force exerted by q_1 on q_2 and in the opposite direction; that is, $\vec{\mathbf{F}}_{21} = -\vec{\mathbf{F}}_{12}$. Finally, Equation 23.6 shows that if q_1 and q_2 have the

Figure 23.6 Two point charges separated by a distance r exert a force on each other that is given by Coulomb's law. The force \vec{F}_{21} exerted by q_2 on q_1 is equal in magnitude and opposite in direction to the force \vec{F}_{12} exerted by q_1 on q_2 .

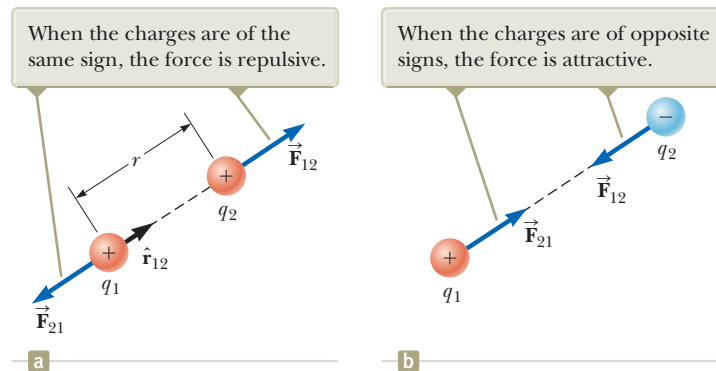

same sign as in Figure 23.6a, the product q_1q_2 is positive and the electric force on one particle is directed away from the other particle. If q_1 and q_2 are of opposite sign as shown in Figure 23.6b, the product q_1q_2 is negative and the electric force on one particle is directed toward the other particle. These signs describe the *relative* direction of the force but not the *absolute* direction. A negative product indicates an attractive force, and a positive product indicates a repulsive force. The *absolute* direction of the force on a charge depends on the location of the other charge. For example, if an x axis lies along the two charges in Figure 23.6a, the product q_1q_2 is positive, but \vec{F}_{12} points in the positive x direction and \vec{F}_{21} points in the negative x direction.

When more than two charges are present, the force between any pair of them is given by Equation 23.6. Therefore, the resultant force on any one of them equals the vector sum of the forces exerted by the other individual charges. For example, if four charges are present, the resultant force exerted by particles 2, 3, and 4 on particle 1 is

$$\vec{F}_1 = \vec{F}_{21} + \vec{F}_{31} + \vec{F}_{41}$$

- Quick Quiz 23.3** Object A has a charge of $+2 \mu\text{C}$, and object B has a charge of $+6 \mu\text{C}$. Which statement is true about the electric forces on the objects?
- (a) $\vec{F}_{AB} = -3\vec{F}_{BA}$ (b) $\vec{F}_{AB} = -\vec{F}_{BA}$ (c) $3\vec{F}_{AB} = -\vec{F}_{BA}$ (d) $\vec{F}_{AB} = 3\vec{F}_{BA}$
 - (e) $\vec{F}_{AB} = \vec{F}_{BA}$ (f) $3\vec{F}_{AB} = \vec{F}_{BA}$

Example 23.2 Find the Resultant Force

Consider three point charges located at the corners of a right triangle as shown in Figure 23.7, where $q_1 = q_3 = 5.00 \mu\text{C}$, $q_2 = -2.00 \mu\text{C}$, and $a = 0.100 \text{ m}$. Find the resultant force exerted on q_3 .

SOLUTION

Conceptualize Think about the net force on q_3 . Because charge q_3 is near two other charges, it will experience two electric forces. These forces are exerted in different directions as shown in Figure 23.7. Based on the forces shown in the figure, estimate the direction of the net force vector.

Categorize Because two forces are exerted on charge q_3 , we categorize this example as a vector addition problem.

Analyze The directions of the individual forces exerted by q_1 and q_2 on q_3 are shown in Figure 23.7. The force \vec{F}_{23} exerted by q_2 on q_3 is attractive because q_2 and q_3 have opposite signs. In the coordinate system shown in Figure 23.7, the attractive force \vec{F}_{23} is to the left (in the negative x direction).

The force \vec{F}_{13} exerted by q_1 on q_3 is repulsive because both charges are positive. The repulsive force \vec{F}_{13} makes an angle of 45.0° with the x axis.

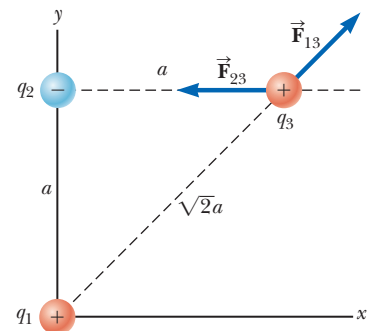

Figure 23.7 (Example 23.2) The force exerted by q_1 on q_3 is \vec{F}_{13} . The force exerted by q_2 on q_3 is \vec{F}_{23} . The resultant force \vec{F}_3 exerted on q_3 is the vector sum $\vec{F}_{13} + \vec{F}_{23}$.

23.2 continued

Use Equation 23.1 to find the magnitude of \vec{F}_{23} :

$$F_{23} = k_e \frac{|q_2||q_3|}{a^2} = (8.988 \times 10^9 \text{ N} \cdot \text{m}^2/\text{C}^2) \frac{(2.00 \times 10^{-6} \text{ C})(5.00 \times 10^{-6} \text{ C})}{(0.100 \text{ m})^2} = 8.99 \text{ N}$$

Find the magnitude of the force \vec{F}_{13} :

$$F_{13} = k_e \frac{|q_1||q_3|}{(\sqrt{2}a)^2} = (8.988 \times 10^9 \text{ N} \cdot \text{m}^2/\text{C}^2) \frac{(5.00 \times 10^{-6} \text{ C})(5.00 \times 10^{-6} \text{ C})}{2(0.100 \text{ m})^2} = 11.2 \text{ N}$$

Find the x and y components of the force \vec{F}_{13} :

$$F_{13x} = (11.2 \text{ N}) \cos 45.0^\circ = 7.94 \text{ N}$$

$$F_{13y} = (11.2 \text{ N}) \sin 45.0^\circ = 7.94 \text{ N}$$

Find the components of the resultant force acting on q_3 :

$$F_{3x} = F_{13x} + F_{23x} = 7.94 \text{ N} + (-8.99 \text{ N}) = -1.04 \text{ N}$$

$$F_{3y} = F_{13y} + F_{23y} = 7.94 \text{ N} + 0 = 7.94 \text{ N}$$

Express the resultant force acting on q_3 in unit-vector form:

$$\vec{F}_3 = (-1.04 \hat{i} + 7.94 \hat{j}) \text{ N}$$

Finalize The net force on q_3 is upward and toward the left in Figure 23.7. If q_3 moves in response to the net force, the distances between q_3 and the other charges change, so the net force changes. Therefore, if q_3 is free to move, it can be modeled as a particle under a net force as long as it is recognized that the force exerted on q_3 is *not* constant. As a reminder, we display most numerical values to three significant figures, which leads to operations such as $7.94 \text{ N} + (-8.99 \text{ N}) = -1.04 \text{ N}$ above. If you carry all intermediate results to more significant figures, you will see that this operation is correct.

WHAT IF? What if the signs of all three charges were changed to the opposite signs? How would that affect the result for \vec{F}_3 ?

Answer The charge q_3 would still be attracted toward q_2 and repelled from q_1 with forces of the same magnitude. Therefore, the final result for \vec{F}_3 would be the same.

Example 23.3 Where Is the Net Force Zero? AM

Three point charges lie along the x axis as shown in Figure 23.8. The positive charge $q_1 = 15.0 \mu\text{C}$ is at $x = 2.00 \text{ m}$, the positive charge $q_2 = 6.00 \mu\text{C}$ is at the origin, and the net force acting on q_3 is zero. What is the x coordinate of q_3 ?

SOLUTION

Conceptualize Because q_3 is near two other charges, it experiences two electric forces. Unlike the preceding example, however, the forces lie along the same line in this problem as indicated in Figure 23.8. Because q_3 is negative and q_1 and q_2 are positive, the forces \vec{F}_{13} and \vec{F}_{23} are both attractive. Because q_2 is the smaller charge, the position of q_3 at which the force is zero should be closer to q_2 than to q_1 .

Categorize Because the net force on q_3 is zero, we model the point charge as a *particle in equilibrium*.

Analyze Write an expression for the net force on charge q_3 when it is in equilibrium:

$$\vec{F}_3 = \vec{F}_{23} + \vec{F}_{13} = -k_e \frac{|q_2||q_3|}{x^2} \hat{i} + k_e \frac{|q_1||q_3|}{(2.00 - x)^2} \hat{i} = 0$$

Move the second term to the right side of the equation and set the coefficients of the unit vector \hat{i} equal:

$$k_e \frac{|q_2||q_3|}{x^2} = k_e \frac{|q_1||q_3|}{(2.00 - x)^2}$$

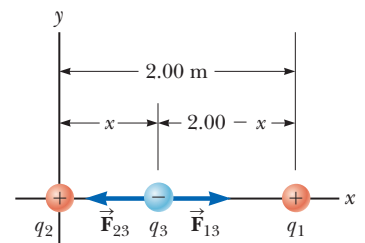

Figure 23.8 (Example 23.3) Three point charges are placed along the x axis. If the resultant force acting on q_3 is zero, the force \vec{F}_{13} exerted by q_1 on q_3 must be equal in magnitude and opposite in direction to the force \vec{F}_{23} exerted by q_2 on q_3 .

continued

23.3 continued

Eliminate k_e and $|q_3|$ and rearrange the equation:

$$(2.00 - x)^2 |q_2| = x^2 |q_1|$$

Take the square root of both sides of the equation:

$$(2.00 - x) \sqrt{|q_2|} = \pm x \sqrt{|q_1|}$$

Solve for x :

$$x = \frac{2.00 \sqrt{|q_2|}}{\sqrt{|q_2|} \pm \sqrt{|q_1|}}$$

Substitute numerical values, choosing the plus sign:

$$x = \frac{2.00 \sqrt{6.00 \times 10^{-6} \text{ C}}}{\sqrt{6.00 \times 10^{-6} \text{ C}} + \sqrt{15.0 \times 10^{-6} \text{ C}}} = 0.775 \text{ m}$$

Finalize Notice that the movable charge is indeed closer to q_2 as we predicted in the Conceptualize step. The second solution to the equation (if we choose the negative sign) is $x = -3.44 \text{ m}$. That is another location where the *magnitudes* of the forces on q_3 are equal, but both forces are in the same direction, so they do not cancel.

WHAT IF? Suppose q_3 is constrained to move only along the x axis. From its initial position at $x = 0.775 \text{ m}$, it is pulled a small distance along the x axis. When released, does it return to equilibrium, or is it pulled farther from equilibrium? That is, is the equilibrium stable or unstable?

Answer If q_3 is moved to the right, \vec{F}_{13} becomes larger and \vec{F}_{23} becomes smaller. The result is a net force to the right, in the same direction as the displacement. Therefore, the charge q_3 would continue to move to the right and the equilibrium is *unstable*. (See Section 7.9 for a review of stable and unstable equilibria.)

If q_3 is constrained to stay at a *fixed* x coordinate but allowed to move up and down in Figure 23.8, the equilibrium is stable. In this case, if the charge is pulled upward (or downward) and released, it moves back toward the equilibrium position and oscillates about this point.

Example 23.4 Find the Charge on the Spheres

AM

Two identical small charged spheres, each having a mass of $3.00 \times 10^{-2} \text{ kg}$, hang in equilibrium as shown in Figure 23.9a. The length L of each string is 0.150 m , and the angle θ is 5.00° . Find the magnitude of the charge on each sphere.

SOLUTION

Conceptualize Figure 23.9a helps us conceptualize this example. The two spheres exert repulsive forces on each other. If they are held close to each other and released, they move outward from the center and settle into the configuration in Figure 23.9a after the oscillations have vanished due to air resistance.

Categorize The key phrase “in equilibrium” helps us model each sphere as a *particle in equilibrium*. This example is similar to the particle in equilibrium problems in Chapter 5 with the added feature that one of the forces on a sphere is an electric force.

Analyze The force diagram for the left-hand sphere is shown in Figure 23.9b. The sphere is in equilibrium under the application of the force \vec{T} from the string, the electric force \vec{F}_e from the other sphere, and the gravitational force $m\vec{g}$.

From the particle in equilibrium model, set the net force on the left-hand sphere equal to zero for each component:

Divide Equation (1) by Equation (2) to find F_e :

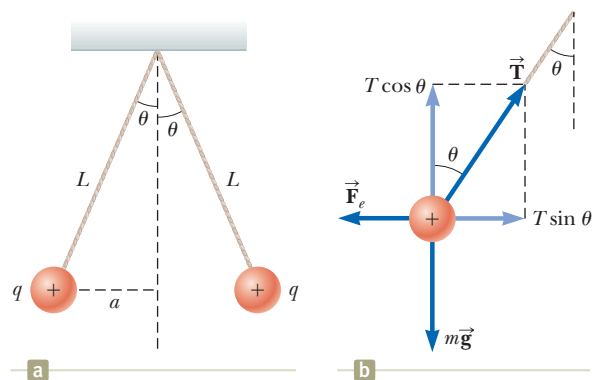

Figure 23.9 (Example 23.4) (a) Two identical spheres, each carrying the same charge q , suspended in equilibrium. (b) Diagram of the forces acting on the sphere on the left part of (a).

$$\begin{aligned} (1) \quad \sum F_x &= T \sin \theta - F_e = 0 \rightarrow T \sin \theta = F_e \\ (2) \quad \sum F_y &= T \cos \theta - mg = 0 \rightarrow T \cos \theta = mg \\ (3) \quad \tan \theta &= \frac{F_e}{mg} \rightarrow F_e = mg \tan \theta \end{aligned}$$

Use the geometry of the right triangle in Figure 23.9a to find a relationship between θ , l , and r .

$$(4) \sin \theta = \frac{r}{l}$$

Solve Coulomb's law (Eq. 23.1) for the charge q on each sphere and substitute from Equations (3) and (4):

Substitute numerical values:

$$\frac{(3.00 \times 10^{-6} \text{ kg})(9.80 \text{ m/s}^2) \tan 5.00^\circ}{(8.988 \times 10^9 \text{ N}\cdot\text{m}^2/\text{C}^2)} = \frac{(0.150 \text{ m} \sin 5.00^\circ)^2}{q^2}$$

$$q = 4.42 \times 10^{-6} \text{ C}$$

Finalize If the sign of the charges were not given in Figure 23.9, we could not determine them. In fact, the sign of the charge is not important. The situation is the same whether both spheres are positively charged or negatively charged.

WHAT IF? Suppose your roommate proposes solving this problem without the assumption that the charges are of equal magnitude. She claims the symmetry of the problem is destroyed if the charges are not equal, so the strings would make two different angles with the vertical and the problem would be much more complicated. How would you respond?

Answer The symmetry is not destroyed and the angles are not different. Newton's third law requires the magnitudes of the electric forces on the two spheres to be the same, regardless of the equality or nonequality of the charges. The solution to the example remains the same with one change: the value of q in the solution is replaced by q_1 in the new situation, where q_1 and q_2 are the values of the charges on the two spheres. The symmetry of the problem would be destroyed if the masses of the spheres were not the same. In this case, the strings would make different angles with the vertical and the problem would be more complicated.

23.4 Analysis Model: Particle in a Field (Electric)

In Section 5.1, we discussed the differences between contact forces and field forces. Two field forces—the gravitational force in Chapter 13 and the electric force here—have been introduced into our discussions so far. As pointed out earlier, field forces can act through space, producing an effect even when no physical contact occurs between interacting objects. Such an interaction can be modeled as a two-step process: a source particle establishes a field, and then a charged particle interacts with the field and experiences a force. The gravitational field \vec{g} at a point in space due to a source particle was defined in Section 13.4 to be equal to the gravitational force \vec{F}_g acting on a test particle of mass m divided by that mass: $\vec{g} = \vec{F}_g/m$. Then the force exerted by the field is $\vec{F} = m\vec{g}$ (Eq. 5.5).

The concept of a field was developed by Michael Faraday (1791–1867) in the context of electric forces and is of such practical value that we shall devote much attention to it in the next several chapters. In this approach, an **electric field** is said to exist in the region of space around a charged object, the **source charge**. The presence of the electric field can be detected by placing a **test charge** in the field and noting the electric force on it. As an example, consider Figure 23.10, which shows a small positive test charge q placed near a second object carrying a much greater positive charge Q . We define the electric field due to the source charge at the location of the test charge to be the electric force on the test charge *per unit charge*, or, to be more specific, the **electric field vector** \vec{E} at a point in space is defined as the electric force \vec{F} acting on a positive test charge q placed at that point divided by the test charge:

$$\vec{E} = \frac{\vec{F}}{q} \quad (23.7)$$

When using Equation 23.7, we must assume the test charge q is small enough that it does not disturb the charge distribution responsible for the electric field. If the test charge is great enough, the charge on the metallic sphere is redistributed and the electric field it sets up is different from the field it sets up in the presence of the much smaller test charge.

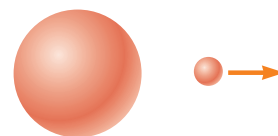
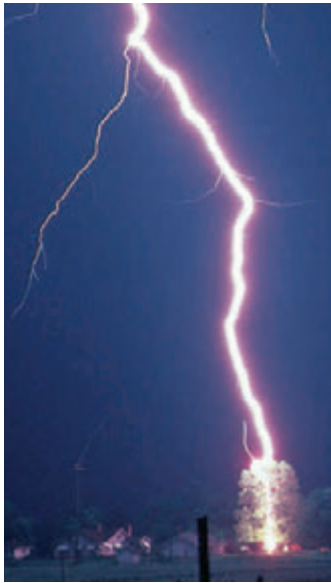

Figure 23.10 A small positive test charge q placed at point P near an object carrying a much larger positive charge Q experiences an electric field \vec{E} at point P established by the source charge Q . We will *always* assume that the test charge is so small that the field of the source charge is unaffected by its presence.

◀ **Definition of electric field**



Courtesy: Johnny Autery

This dramatic photograph captures a lightning bolt striking a tree near some rural homes. Lightning is associated with very strong electric fields in the atmosphere.

The vector $\vec{\mathbf{E}}$ has the SI units of newtons per coulomb (N/C). The direction of $\vec{\mathbf{E}}$ as shown in Figure 23.10 is the direction of the force a positive test charge experiences when placed in the field. Note that $\vec{\mathbf{E}}$ is the field produced by some charge or charge distribution *separate from* the test charge; it is not the field produced by the test charge itself. Also note that the existence of an electric field is a property of its source; the presence of the test charge is not necessary for the field to exist. The test charge serves as a *detector* of the electric field: an electric field exists at a point if a test charge at that point experiences an electric force.

If an arbitrary charge q is placed in an electric field $\vec{\mathbf{E}}$, it experiences an electric force given by

$$\vec{\mathbf{F}}_e = q\vec{\mathbf{E}} \quad (23.8)$$

This equation is the mathematical representation of the electric version of the **particle in a field** analysis model. If q is positive, the force is in the same direction as the field. If q is negative, the force and the field are in opposite directions. Notice the similarity between Equation 23.8 and the corresponding equation from the gravitational version of the particle in a field model, $\vec{\mathbf{F}}_g = m\vec{\mathbf{g}}$ (Section 5.5). Once the magnitude and direction of the electric field are known at some point, the electric force exerted on *any* charged particle placed at that point can be calculated from Equation 23.8.

To determine the direction of an electric field, consider a point charge q as a source charge. This charge creates an electric field at all points in space surrounding it. A test charge q_0 is placed at point P , a distance r from the source charge, as in Figure 23.11a. We imagine using the test charge to determine the direction of the electric force and therefore that of the electric field. According to Coulomb's law, the force exerted by q on the test charge is

$$\vec{\mathbf{F}}_e = k_e \frac{qq_0}{r^2} \hat{\mathbf{r}}$$

where $\hat{\mathbf{r}}$ is a unit vector directed from q toward q_0 . This force in Figure 23.11a is directed away from the source charge q . Because the electric field at P , the position of the test charge, is defined by $\vec{\mathbf{E}} = \vec{\mathbf{F}}_e/q_0$, the electric field at P created by q is

$$\vec{\mathbf{E}} = k_e \frac{q}{r^2} \hat{\mathbf{r}} \quad (23.9)$$

If the source charge q is positive, Figure 23.11b shows the situation with the test charge removed: the source charge sets up an electric field at P , directed away from q . If q is

Pitfall Prevention 23.1

Particles Only Equation 23.8 is valid only for a *particle* of charge q , that is, an object of zero size. For a charged *object* of finite size in an electric field, the field may vary in magnitude and direction over the size of the object, so the corresponding force equation may be more complicated.

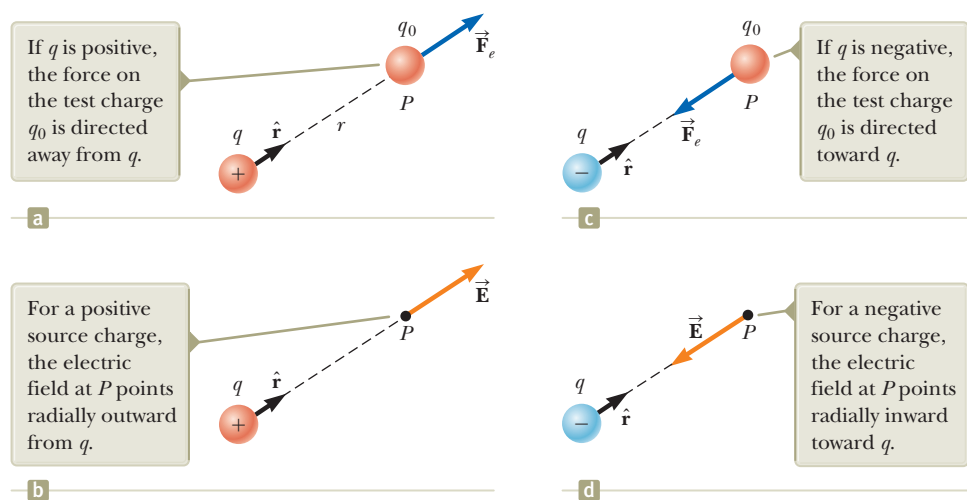

Figure 23.11 (a), (c) When a test charge q_0 is placed near a source charge q , the test charge experiences a force. (b), (d) At a point P near a source charge q , there exists an electric field.

negative as in Figure 23.11c, the force on the test charge is toward the source charge, so the electric field at P is directed toward the source charge as in Figure 23.11d.

To calculate the electric field at a point P due to a small number of point charges, we first calculate the electric field vectors at P individually using Equation 23.9 and then add them vectorially. In other words, at any point P , the total electric field due to a group of source charges equals the vector sum of the electric fields of all the charges. This superposition principle applied to fields follows directly from the vector addition of electric forces. Therefore, the electric field at point P due to a group of source charges can be expressed as the vector sum

$$\vec{\mathbf{E}} = k_e \sum_i \frac{q_i}{r_i^2} \hat{\mathbf{r}}_i \quad (23.10)$$

◀ Electric field due to a finite number of point charges

where r_i is the distance from the i th source charge q_i to the point P and $\hat{\mathbf{r}}_i$ is a unit vector directed from q_i toward P .

In Example 23.6, we explore the electric field due to two charges using the superposition principle. Part (B) of the example focuses on an **electric dipole**, which is defined as a positive charge q and a negative charge $-q$ separated by a distance $2a$. The electric dipole is a good model of many molecules, such as hydrochloric acid (HCl). Neutral atoms and molecules behave as dipoles when placed in an external electric field. Furthermore, many molecules, such as HCl, are permanent dipoles. The effect of such dipoles on the behavior of materials subjected to electric fields is discussed in Chapter 26.

- Quick Quiz 23.4** A test charge of $+3 \mu\text{C}$ is at a point P where an external electric field is directed to the right and has a magnitude of $4 \times 10^6 \text{ N/C}$. If the test charge is replaced with another test charge of $-3 \mu\text{C}$, what happens to the external electric field at P ? (a) It is unaffected. (b) It reverses direction. (c) It changes in a way that cannot be determined.

Analysis Model Particle in a Field (Electric)

Imagine an object with charge that we call a *source charge*. The source charge establishes an **electric field** $\vec{\mathbf{E}}$ throughout space. Now imagine a particle with charge q is placed in that field. The particle interacts with the electric field so that the particle experiences an electric force given by

$$\vec{\mathbf{F}}_e = q\vec{\mathbf{E}} \quad (23.8)$$

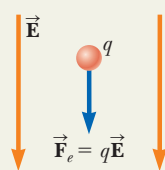

Examples:

- an electron moves between the deflection plates of a cathode ray oscilloscope and is deflected from its original path
- charged ions experience an electric force from the electric field in a velocity selector before entering a mass spectrometer (Chapter 29)
- an electron moves around the nucleus in the electric field established by the proton in a hydrogen atom as modeled by the Bohr theory (Chapter 42)
- a hole in a semiconducting material moves in response to the electric field established by applying a voltage to the material (Chapter 43)

Example 23.5 A Suspended Water Droplet AM

A water droplet of mass $3.00 \times 10^{-12} \text{ kg}$ is located in the air near the ground during a stormy day. An atmospheric electric field of magnitude $6.00 \times 10^3 \text{ N/C}$ points vertically downward in the vicinity of the water droplet. The droplet remains suspended at rest in the air. What is the electric charge on the droplet?

SOLUTION

Conceptualize Imagine the water droplet hovering at rest in the air. This situation is not what is normally observed, so something must be holding the water droplet up. *continued*

23.5 continued

Categorize The droplet can be modeled as a particle and is described by two analysis models associated with fields: the *particle in a field (gravitational)* and the *particle in a field (electric)*. Furthermore, because the droplet is subject to forces but remains at rest, it is also described by the *particle in equilibrium* model.

Analyze

Write Newton's second law from the particle in equilibrium model in the vertical direction:

$$(1) \quad \sum F_y = 0 \rightarrow F_e - F_g = 0$$

Using the two particle in a field models mentioned in the Categorize step, substitute for the forces in Equation (1), recognizing that the vertical component of the electric field is negative:

$$q(-E) - mg = 0$$

Solve for the charge on the water droplet:

$$q = -\frac{mg}{E}$$

Substitute numerical values:

$$q = -\frac{(3.00 \times 10^{-12} \text{ kg})(9.80 \text{ m/s}^2)}{6.00 \times 10^3 \text{ N/C}} = -4.90 \times 10^{-15} \text{ C}$$

Finalize Noting the smallest unit of free charge in Equation 23.5, the charge on the water droplet is a large number of these units. Notice that the electric *force* is upward to balance the downward gravitational force. The problem statement claims that the electric *field* is in the downward direction. Therefore, the charge found above is negative so that the electric force is in the direction opposite to the electric field.

Example 23.6 Electric Field Due to Two Charges

Charges q_1 and q_2 are located on the x axis, at distances a and b , respectively, from the origin as shown in Figure 23.12.

(A) Find the components of the net electric field at the point P , which is at position $(0, y)$.

SOLUTION

Conceptualize Compare this example with Example 23.2. There, we add vector forces to find the net force on a charged particle. Here, we add electric field vectors to find the net electric field at a point in space. If a charged particle were placed at P , we could use the particle in a field model to find the electric force on the particle.

Categorize We have two source charges and wish to find the resultant electric field, so we categorize this example as one in which we can use the superposition principle represented by Equation 23.10.

Analyze Find the magnitude of the electric field at P due to charge q_1 :

$$E_1 = k_e \frac{|q_1|}{r_1^2} = k_e \frac{|q_1|}{a^2 + y^2}$$

Find the magnitude of the electric field at P due to charge q_2 :

$$E_2 = k_e \frac{|q_2|}{r_2^2} = k_e \frac{|q_2|}{b^2 + y^2}$$

Write the electric field vectors for each charge in unit-vector form:

$$\vec{E}_1 = k_e \frac{|q_1|}{a^2 + y^2} \cos \phi \hat{i} + k_e \frac{|q_1|}{a^2 + y^2} \sin \phi \hat{j}$$

$$\vec{E}_2 = k_e \frac{|q_2|}{b^2 + y^2} \cos \theta \hat{i} - k_e \frac{|q_2|}{b^2 + y^2} \sin \theta \hat{j}$$

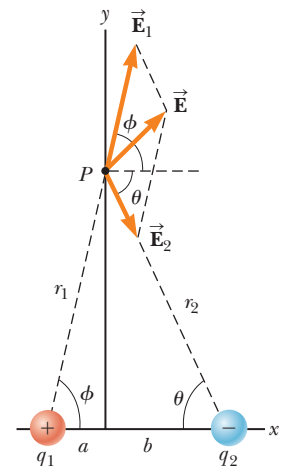

Figure 23.12 (Example 23.6) The total electric field \vec{E} at P equals the vector sum $\vec{E}_1 + \vec{E}_2$, where \vec{E}_1 is the field due to the positive charge q_1 and \vec{E}_2 is the field due to the negative charge q_2 .

23.6 continued

Write the components of the net electric field vector:

$$(1) \quad E_x = E_{1x} + E_{2x} = k_e \frac{|q_1|}{a^2 + y^2} \cos \phi + k_e \frac{|q_2|}{b^2 + y^2} \cos \theta$$

$$(2) \quad E_y = E_{1y} + E_{2y} = k_e \frac{|q_1|}{a^2 + y^2} \sin \phi - k_e \frac{|q_2|}{b^2 + y^2} \sin \theta$$

(B) Evaluate the electric field at point P in the special case that $|q_1| = |q_2|$ and $a = b$.

SOLUTION

Conceptualize Figure 23.13 shows the situation in this special case. Notice the symmetry in the situation and that the charge distribution is now an electric dipole.

Categorize Because Figure 23.13 is a special case of the general case shown in Figure 23.12, we can categorize this example as one in which we can take the result of part (A) and substitute the appropriate values of the variables.

Analyze Based on the symmetry in Figure 23.13, evaluate Equations (1) and (2) from part (A) with $a = b$, $|q_1| = |q_2| = q$, and $\phi = \theta$:

$$(3) \quad E_x = k_e \frac{q}{a^2 + y^2} \cos \theta + k_e \frac{q}{a^2 + y^2} \cos \theta = 2k_e \frac{q}{a^2 + y^2} \cos \theta$$

$$E_y = k_e \frac{q}{a^2 + y^2} \sin \theta - k_e \frac{q}{a^2 + y^2} \sin \theta = 0$$

From the geometry in Figure 23.13, evaluate $\cos \theta$:

$$(4) \quad \cos \theta = \frac{a}{r} = \frac{a}{(a^2 + y^2)^{1/2}}$$

Substitute Equation (4) into Equation (3):

$$E_x = 2k_e \frac{q}{a^2 + y^2} \left[\frac{a}{(a^2 + y^2)^{1/2}} \right] = k_e \frac{2aq}{(a^2 + y^2)^{3/2}}$$

(C) Find the electric field due to the electric dipole when point P is a distance $y \gg a$ from the origin.

SOLUTION

In the solution to part (B), because $y \gg a$, neglect a^2 compared with y^2 and write the expression for E in this case:

$$(5) \quad E \approx k_e \frac{2aq}{y^3}$$

Finalize From Equation (5), we see that at points far from a dipole but along the perpendicular bisector of the line joining the two charges, the magnitude of the electric field created by the dipole varies as $1/r^3$, whereas the more slowly varying field of a point charge varies as $1/r^2$ (see Eq. 23.9). That is because at distant points, the fields of the two charges of equal magnitude and opposite sign almost cancel each other. The $1/r^3$ variation in E for the dipole also is obtained for a distant point along the x axis and for any general distant point.

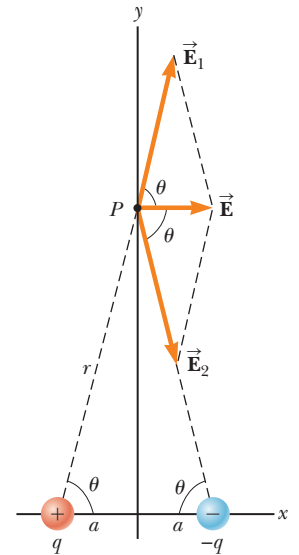

Figure 23.13 (Example 23.6) When the charges in Figure 23.12 are of equal magnitude and equidistant from the origin, the situation becomes symmetric as shown here.

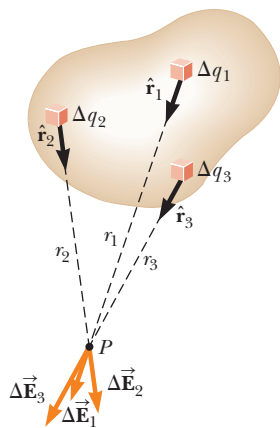

Figure 23.14 The electric field at P due to a continuous charge distribution is the vector sum of the fields $\Delta\vec{E}_i$ due to all the elements Δq_i of the charge distribution. Three sample elements are shown.

23.5 Electric Field of a Continuous Charge Distribution

Equation 23.10 is useful for calculating the electric field due to a small number of charges. In many cases, we have a continuous distribution of charge rather than a collection of discrete charges. The charge in these situations can be described as continuously distributed along some line, over some surface, or throughout some volume.

To set up the process for evaluating the electric field created by a continuous charge distribution, let's use the following procedure. First, divide the charge distribution into small elements, each of which contains a small charge Δq as shown in Figure 23.14. Next, use Equation 23.9 to calculate the electric field due to one of these elements at a point P . Finally, evaluate the total electric field at P due to the charge distribution by summing the contributions of all the charge elements (that is, by applying the superposition principle).

The electric field at P due to one charge element carrying charge Δq is

$$\Delta\vec{E} = k_e \frac{\Delta q}{r^2} \hat{r}$$

where r is the distance from the charge element to point P and \hat{r} is a unit vector directed from the element toward P . The total electric field at P due to all elements in the charge distribution is approximately

$$\vec{E} \approx k_e \sum_i \frac{\Delta q_i}{r_i^2} \hat{r}_i$$

where the index i refers to the i th element in the distribution. Because the number of elements is very large and the charge distribution is modeled as continuous, the total field at P in the limit $\Delta q_i \rightarrow 0$ is

$$\vec{E} = k_e \lim_{\Delta q_i \rightarrow 0} \sum_i \frac{\Delta q_i}{r_i^2} \hat{r}_i = k_e \int \frac{dq}{r^2} \hat{r} \quad (23.11)$$

where the integration is over the entire charge distribution. The integration in Equation 23.11 is a vector operation and must be treated appropriately.

Let's illustrate this type of calculation with several examples in which the charge is distributed on a line, on a surface, or throughout a volume. When performing such calculations, it is convenient to use the concept of a *charge density* along with the following notations:

- If a charge Q is uniformly distributed throughout a volume V , the **volume charge density** ρ is defined by

$$\rho \equiv \frac{Q}{V}$$

where ρ has units of coulombs per cubic meter (C/m^3).

- If a charge Q is uniformly distributed on a surface of area A , the **surface charge density** σ (Greek letter sigma) is defined by

$$\sigma \equiv \frac{Q}{A}$$

where σ has units of coulombs per square meter (C/m^2).

- If a charge Q is uniformly distributed along a line of length ℓ , the **linear charge density** λ is defined by

$$\lambda \equiv \frac{Q}{\ell}$$

where λ has units of coulombs per meter (C/m).

Electric field due to a continuous charge distribution ►

Volume charge density ►

Surface charge density ►

Linear charge density ►

- If the charge is nonuniformly distributed over a volume, surface, or line, the amounts of charge dq in a small volume, surface, or length element are

$$dq = \rho dV \quad dq = \sigma dA \quad dq = \lambda d\ell$$

Problem-Solving Strategy Calculating the Electric Field

The following procedure is recommended for solving problems that involve the determination of an electric field due to individual charges or a charge distribution.

1. Conceptualize. Establish a mental representation of the problem: think carefully about the individual charges or the charge distribution and imagine what type of electric field it would create. Appeal to any symmetry in the arrangement of charges to help you visualize the electric field.

2. Categorize. Are you analyzing a group of individual charges or a continuous charge distribution? The answer to this question tells you how to proceed in the Analyze step.

3. Analyze.

(a) If you are analyzing a group of individual charges, use the superposition principle: when several point charges are present, the resultant field at a point in space is the *vector sum* of the individual fields due to the individual charges (Eq. 23.10). Be very careful in the manipulation of vector quantities. It may be useful to review the material on vector addition in Chapter 3. Example 23.6 demonstrated this procedure.

(b) If you are analyzing a continuous charge distribution, the superposition principle is applied by replacing the vector sums for evaluating the total electric field from individual charges by vector integrals. The charge distribution is divided into infinitesimal pieces, and the vector sum is carried out by integrating over the entire charge distribution (Eq. 23.11). Examples 23.7 through 23.9 demonstrate such procedures.

Consider symmetry when dealing with either a distribution of point charges or a continuous charge distribution. Take advantage of any symmetry in the system you observed in the Conceptualize step to simplify your calculations. The cancellation of field components perpendicular to the axis in Example 23.8 is an example of the application of symmetry.

4. Finalize. Check to see if your electric field expression is consistent with the mental representation and if it reflects any symmetry that you noted previously. Imagine varying parameters such as the distance of the observation point from the charges or the radius of any circular objects to see if the mathematical result changes in a reasonable way.

Example 23.7 The Electric Field Due to a Charged Rod

A rod of length ℓ has a uniform positive charge per unit length λ and a total charge Q . Calculate the electric field at a point P that is located along the long axis of the rod and a distance a from one end (Fig. 23.15).

SOLUTION

Conceptualize The field $d\vec{E}$ at P due to each segment of charge on the rod is in the negative x direction because every segment carries a positive charge. Figure 23.15 shows the appropriate geometry. In our result, we expect the electric field to become smaller as the distance a becomes larger because point P is farther from the charge distribution.

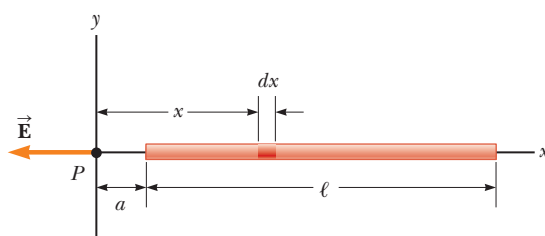

Figure 23.15 (Example 23.7) The electric field at P due to a uniformly charged rod lying along the x axis.

continued

23.7 continued

Categorize Because the rod is continuous, we are evaluating the field due to a continuous charge distribution rather than a group of individual charges. Because every segment of the rod produces an electric field in the negative x direction, the sum of their contributions can be handled without the need to add vectors.

Analyze Let's assume the rod is lying along the x axis, dx is the length of one small segment, and dq is the charge on that segment. Because the rod has a charge per unit length λ , the charge dq on the small segment is $dq = \lambda dx$.

Find the magnitude of the electric field at P due to one segment of the rod having a charge dq :

$$dE = k_e \frac{dq}{x^2} = k_e \frac{\lambda dx}{x^2}$$

Find the total field at P using⁴ Equation 23.11:

$$E = \int_a^{\ell+a} k_e \lambda \frac{dx}{x^2}$$

Noting that k_e and $\lambda = Q/\ell$ are constants and can be removed from the integral, evaluate the integral:

$$E = k_e \lambda \int_a^{\ell+a} \frac{dx}{x^2} = k_e \lambda \left[-\frac{1}{x} \right]_a^{\ell+a}$$

$$(1) \quad E = k_e \frac{Q}{\ell} \left(\frac{1}{a} - \frac{1}{\ell + a} \right) = \frac{k_e Q}{a(\ell + a)}$$

Finalize We see that our prediction is correct; if a becomes larger, the denominator of the fraction grows larger, and E becomes smaller. On the other hand, if $a \rightarrow 0$, which corresponds to sliding the bar to the left until its left end is at the origin, then $E \rightarrow \infty$. That represents the condition in which the observation point P is at zero distance from the charge at the end of the rod, so the field becomes infinite. We explore large values of a below.

WHAT IF? Suppose point P is very far away from the rod. What is the nature of the electric field at such a point?

Answer If P is far from the rod ($a \gg \ell$), then ℓ in the denominator of Equation (1) can be neglected and $E \approx k_e Q/a^2$. That is exactly the form you would expect for a point charge. Therefore, at large values of a/ℓ , the charge distribution appears to be a point charge of magnitude Q ; the point P is so far away from the rod we cannot distinguish that it has a size. The use of the limiting technique ($a/\ell \rightarrow \infty$) is often a good method for checking a mathematical expression.

Example 23.8 The Electric Field of a Uniform Ring of Charge

A ring of radius a carries a uniformly distributed positive total charge Q . Calculate the electric field due to the ring at a point P lying a distance x from its center along the central axis perpendicular to the plane of the ring (Fig. 23.16a).

SOLUTION

Conceptualize Figure 23.16a shows the electric field contribution $d\vec{E}$ at P due to a single segment of charge at the top of the ring. This field vector can be resolved into components dE_x parallel to

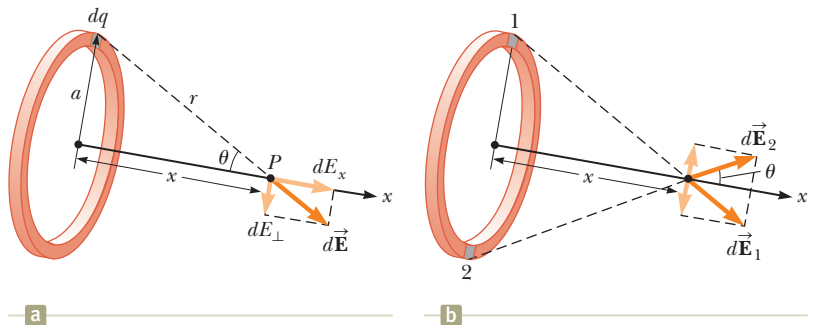

Figure 23.16 (Example 23.8) A uniformly charged ring of radius a . (a) The field at P on the x axis due to an element of charge dq . (b) The total electric field at P is along the x axis. The perpendicular component of the field at P due to segment 1 is canceled by the perpendicular component due to segment 2.

⁴To carry out integrations such as this one, first express the charge element dq in terms of the other variables in the integral. (In this example, there is one variable, x , so we made the change $dq = \lambda dx$.) The integral must be over scalar quantities; therefore, express the electric field in terms of components, if necessary. (In this example, the field has only an x component, so this detail is of no concern.) Then, reduce your expression to an integral over a single variable (or to multiple integrals, each over a single variable). In examples that have spherical or cylindrical symmetry, the single variable is a radial coordinate.

23.8 continued

the axis of the ring and dE_{\perp} perpendicular to the axis. Figure 23.16b shows the electric field contributions from two segments on opposite sides of the ring. Because of the symmetry of the situation, the perpendicular components of the field cancel. That is true for all pairs of segments around the ring, so we can ignore the perpendicular component of the field and focus solely on the parallel components, which simply add.

Categorize Because the ring is continuous, we are evaluating the field due to a continuous charge distribution rather than a group of individual charges.

Analyze Evaluate the parallel component of an electric field contribution from a segment of charge dq on the ring:

$$(1) \quad dE_x = k_e \frac{dq}{r^2} \cos \theta = k_e \frac{dq}{a^2 + x^2} \cos \theta$$

From the geometry in Figure 23.16a, evaluate $\cos \theta$:

$$(2) \quad \cos \theta = \frac{x}{r} = \frac{x}{(a^2 + x^2)^{1/2}}$$

Substitute Equation (2) into Equation (1):

$$dE_x = k_e \frac{dq}{a^2 + x^2} \left[\frac{x}{(a^2 + x^2)^{1/2}} \right] = \frac{k_e x}{(a^2 + x^2)^{3/2}} dq$$

All segments of the ring make the same contribution to the field at P because they are all equidistant from this point. Integrate over the circumference of the ring to obtain the total field at P :

$$E_x = \int \frac{k_e x}{(a^2 + x^2)^{3/2}} dq = \frac{k_e x}{(a^2 + x^2)^{3/2}} \int dq$$

$$(3) \quad E = \frac{k_e x}{(a^2 + x^2)^{3/2}} Q$$

Finalize This result shows that the field is zero at $x = 0$. Is that consistent with the symmetry in the problem? Furthermore, notice that Equation (3) reduces to $k_e Q/x^2$ if $x \gg a$, so the ring acts like a point charge for locations far away from the ring. From a faraway point, we cannot distinguish the ring shape of the charge.

WHAT IF? Suppose a negative charge is placed at the center of the ring in Figure 23.16 and displaced slightly by a distance $x \ll a$ along the x axis. When the charge is released, what type of motion does it exhibit?

Answer In the expression for the field due to a ring of charge, let $x \ll a$, which results in

$$E_x = \frac{k_e Q}{a^3} x$$

Therefore, from Equation 23.8, the force on a charge $-q$ placed near the center of the ring is

$$F_x = -\frac{k_e q Q}{a^3} x$$

Because this force has the form of Hooke's law (Eq. 15.1), the motion of the negative charge is described with the *particle in simple harmonic motion model!*

Example 23.9 The Electric Field of a Uniformly Charged Disk

A disk of radius R has a uniform surface charge density σ . Calculate the electric field at a point P that lies along the central perpendicular axis of the disk and a distance x from the center of the disk (Fig. 23.17).

SOLUTION

Conceptualize If the disk is considered to be a set of concentric rings, we can use our result from Example 23.8—which gives the field created by a single ring of radius a —and sum the contributions of all rings making up the disk. By symmetry, the field at an axial point must be along the central axis.

Figure 23.17 (Example 23.9) A uniformly charged disk of radius R . The electric field at an axial point P is directed along the central axis, perpendicular to the plane of the disk.

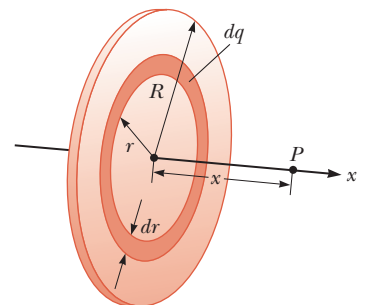

continued

23.9 continued

Categorize Because the disk is continuous, we are evaluating the field due to a continuous charge distribution rather than a group of individual charges.

Analyze Find the amount of charge dq on the surface area of a ring of radius r and width dr as shown in Figure 23.17:

$$dq = \sigma dA = \sigma(2\pi r dr) = 2\pi\sigma r dr$$

Use this result in the equation given for E_x in Example 23.8 (with a replaced by r and Q replaced by dq) to find the field due to the ring:

$$dE_x = \frac{k_e x}{(r^2 + x^2)^{3/2}} (2\pi\sigma r dr)$$

To obtain the total field at P , integrate this expression over the limits $r = 0$ to $r = R$, noting that x is a constant in this situation:

$$\begin{aligned} E_x &= k_e x \pi \sigma \int_0^R \frac{2r dr}{(r^2 + x^2)^{3/2}} \\ &= k_e x \pi \sigma \int_0^R (r^2 + x^2)^{-3/2} d(r^2) \end{aligned}$$

$$= k_e x \pi \sigma \left[\frac{(r^2 + x^2)^{-1/2}}{-1/2} \right]_0^R = 2\pi k_e \sigma \left[1 - \frac{x}{(R^2 + x^2)^{1/2}} \right]$$

Finalize This result is valid for all values of $x > 0$. For large values of x , the result above can be evaluated by a series expansion and shown to be equivalent to the electric field of a point charge Q . We can calculate the field close to the disk along the axis by assuming $x \ll R$; in this case, the expression in brackets reduces to unity to give us the near-field approximation

$$E = 2\pi k_e \sigma = \frac{\sigma}{2\epsilon_0}$$

where ϵ_0 is the permittivity of free space. In Chapter 24, we obtain the same result for the field created by an infinite plane of charge with uniform surface charge density.

WHAT IF? What if we let the radius of the disk grow so that the disk becomes an infinite plane of charge?

Answer The result of letting $R \rightarrow \infty$ in the final result of the example is that the magnitude of the electric field becomes

$$E = 2\pi k_e \sigma = \frac{\sigma}{2\epsilon_0}$$

This is the same expression that we obtained for $x \ll R$. If $R \rightarrow \infty$, *everywhere* is near-field—the result is independent of the position at which you measure the electric field. Therefore, the electric field due to an infinite plane of charge is uniform throughout space.

An infinite plane of charge is impossible in practice. If two planes of charge are placed close to each other, however, with one plane positively charged, and the other negatively, the electric field between the plates is very close to uniform at points far from the edges. Such a configuration will be investigated in Chapter 26.

23.6 Electric Field Lines

We have defined the electric field in the mathematical representation with Equation 23.7. Let's now explore a means of visualizing the electric field in a pictorial representation. A convenient way of visualizing electric field patterns is to draw lines, called **electric field lines** and first introduced by Faraday, that are related to the electric field in a region of space in the following manner:

- The electric field vector \vec{E} is tangent to the electric field line at each point. The line has a direction, indicated by an arrowhead, that is the same as that

of the electric field vector. The direction of the line is that of the force on a positive charge placed in the field according to the particle in a field model.

- The number of lines per unit area through a surface perpendicular to the lines is proportional to the magnitude of the electric field in that region. Therefore, the field lines are close together where the electric field is strong and far apart where the field is weak.

These properties are illustrated in Figure 23.18. The density of field lines through surface A is greater than the density of lines through surface B. Therefore, the magnitude of the electric field is larger on surface A than on surface B. Furthermore, because the lines at different locations point in different directions, the field is nonuniform.

Is this relationship between strength of the electric field and the density of field lines consistent with Equation 23.9, the expression we obtained for E using Coulomb's law? To answer this question, consider an imaginary spherical surface of radius r concentric with a point charge. From symmetry, we see that the magnitude of the electric field is the same everywhere on the surface of the sphere. The number of lines N that emerge from the charge is equal to the number that penetrate the spherical surface. Hence, the number of lines per unit area on the sphere is $N/4\pi r^2$ (where the surface area of the sphere is $4\pi r^2$). Because E is proportional to the number of lines per unit area, we see that E varies as $1/r^2$; this finding is consistent with Equation 23.9.

Representative electric field lines for the field due to a single positive point charge are shown in Figure 23.19a. This two-dimensional drawing shows only the field lines that lie in the plane containing the point charge. The lines are actually directed radially outward from the charge in all directions; therefore, instead of the flat "wheel" of lines shown, you should picture an entire spherical distribution of lines. Because a positive charge placed in this field would be repelled by the positive source charge, the lines are directed radially away from the source charge. The electric field lines representing the field due to a single negative point charge are directed toward the charge (Fig. 23.19b). In either case, the lines are along the radial direction and extend all the way to infinity. Notice that the lines become closer together as they approach the charge, indicating that the strength of the field increases as we move toward the source charge.

The rules for drawing electric field lines are as follows:

- The lines must begin on a positive charge and terminate on a negative charge. In the case of an excess of one type of charge, some lines will begin or end infinitely far away.

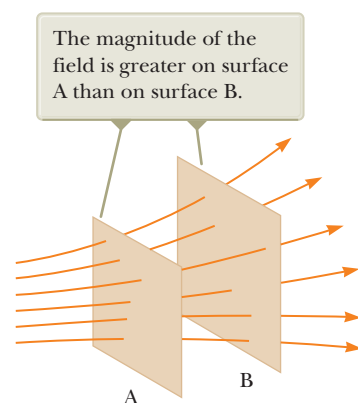
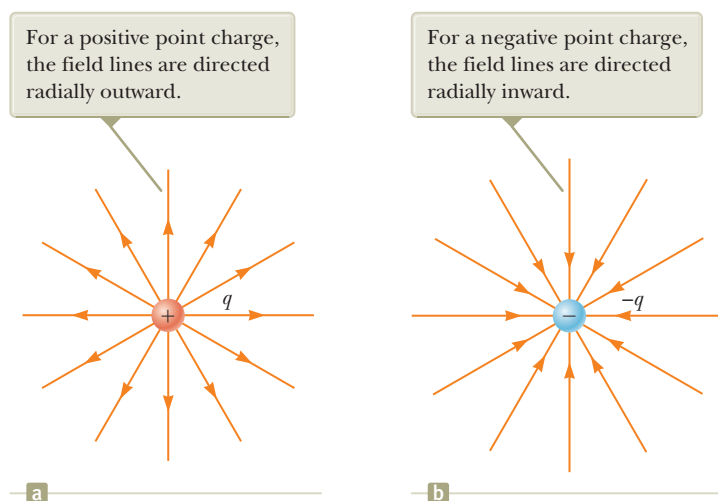

Figure 23.18 Electric field lines penetrating two surfaces.

Pitfall Prevention 23.2

Electric Field Lines Are Not Paths of Particles! Electric field lines represent the field at various locations. Except in very special cases, they *do not* represent the path of a charged particle moving in an electric field.

Figure 23.19 The electric field lines for a point charge. Notice that the figures show only those field lines that lie in the plane of the page.

Pitfall Prevention 23.3**Electric Field Lines Are Not Real**

Electric field lines are not material objects. They are used only as a pictorial representation to provide a qualitative description of the electric field. Only a finite number of lines from each charge can be drawn, which makes it appear as if the field were quantized and exists only in certain parts of space. The field, in fact, is continuous, existing at every point. You should avoid obtaining the wrong impression from a two-dimensional drawing of field lines used to describe a three-dimensional situation.

The number of field lines leaving the positive charge equals the number terminating at the negative charge.

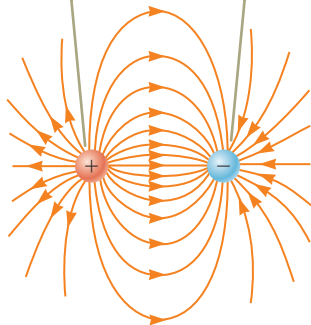

Figure 23.20 The electric field lines for two point charges of equal magnitude and opposite sign (an electric dipole).

- The number of lines drawn leaving a positive charge or approaching a negative charge is proportional to the magnitude of the charge.
- No two field lines can cross.

We choose the number of field lines starting from any object with a positive charge q_+ to be Cq_+ and the number of lines ending on any object with a negative charge q_- to be $C|q_-|$, where C is an arbitrary proportionality constant. Once C is chosen, the number of lines is fixed. For example, in a two-charge system, if object 1 has charge Q_1 and object 2 has charge Q_2 , the ratio of number of lines in contact with the charges is $N_2/N_1 = |Q_2/Q_1|$. The electric field lines for two point charges of equal magnitude but opposite signs (an electric dipole) are shown in Figure 23.20. Because the charges are of equal magnitude, the number of lines that begin at the positive charge must equal the number that terminate at the negative charge. At points very near the charges, the lines are nearly radial, as for a single isolated charge. The high density of lines between the charges indicates a region of strong electric field.

Figure 23.21 shows the electric field lines in the vicinity of two equal positive point charges. Again, the lines are nearly radial at points close to either charge, and the same number of lines emerges from each charge because the charges are equal in magnitude. Because there are no negative charges available, the electric field lines end infinitely far away. At great distances from the charges, the field is approximately equal to that of a single point charge of magnitude $2q$.

Finally, in Figure 23.22, we sketch the electric field lines associated with a positive charge $+2q$ and a negative charge $-q$. In this case, the number of lines leaving $+2q$ is twice the number terminating at $-q$. Hence, only half the lines that leave the positive charge reach the negative charge. The remaining half terminate on a negative charge we assume to be at infinity. At distances much greater than the charge separation, the electric field lines are equivalent to those of a single charge $+q$.

- Quick Quiz 23.5** Rank the magnitudes of the electric field at points A, B, and C shown in Figure 23.21 (greatest magnitude first).

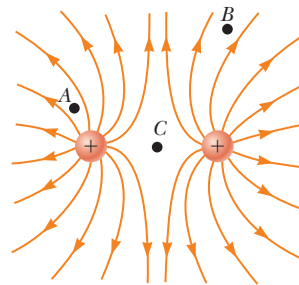

Figure 23.21 The electric field lines for two positive point charges. (The locations A, B, and C are discussed in Quick Quiz 23.5.)

Two field lines leave $+2q$ for every one that terminates on $-q$.

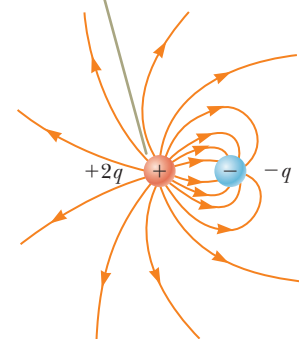

Figure 23.22 The electric field lines for a point charge $+2q$ and a second point charge $-q$.

23.7 Motion of a Charged Particle in a Uniform Electric Field

When a particle of charge q and mass m is placed in an electric field \vec{E} , the electric force exerted on the charge is $q\vec{E}$ according to Equation 23.8 in the particle in a

field model. If that is the only force exerted on the particle, it must be the net force, and it causes the particle to accelerate according to the particle under a net force model. Therefore,

$$\vec{\mathbf{F}}_e = q\vec{\mathbf{E}} = m\vec{\mathbf{a}}$$

and the acceleration of the particle is

$$\vec{\mathbf{a}} = \frac{q\vec{\mathbf{E}}}{m} \quad (23.12)$$

If $\vec{\mathbf{E}}$ is uniform (that is, constant in magnitude and direction), and the particle is free to move, the electric force on the particle is constant and we can apply the particle under constant acceleration model to the motion of the particle. Therefore, the particle in this situation is described by *three* analysis models: particle in a field, particle under a net force, and particle under constant acceleration! If the particle has a positive charge, its acceleration is in the direction of the electric field. If the particle has a negative charge, its acceleration is in the direction opposite the electric field.

Pitfall Prevention 23.4

Just Another Force Electric forces and fields may seem abstract to you. Once $\vec{\mathbf{F}}_e$ is evaluated, however, it causes a particle to move according to our well-established models of forces and motion from Chapters 2 through 6. Keeping this link with the past in mind should help you solve problems in this chapter.

Example 23.10 An Accelerating Positive Charge: Two Models AM

A uniform electric field $\vec{\mathbf{E}}$ is directed along the x axis between parallel plates of charge separated by a distance d as shown in Figure 23.23. A positive point charge q of mass m is released from rest at a point $\textcircled{\text{A}}$ next to the positive plate and accelerates to a point $\textcircled{\text{B}}$ next to the negative plate.

(A) Find the speed of the particle at $\textcircled{\text{B}}$ by modeling it as a particle under constant acceleration.

SOLUTION

Conceptualize When the positive charge is placed at $\textcircled{\text{A}}$, it experiences an electric force toward the right in Figure 23.23 due to the electric field directed toward the right. As a result, it will accelerate to the right and arrive at $\textcircled{\text{B}}$ with some speed.

Categorize Because the electric field is uniform, a constant electric force acts on the charge. Therefore, as suggested in the discussion preceding the example and in the problem statement, the point charge can be modeled as a *charged particle under constant acceleration*.

Analyze Use Equation 2.17 to express the velocity of the particle as a function of position:

$$v_f^2 = v_i^2 + 2a(x_f - x_i) = 0 + 2a(d - 0) = 2ad$$

Solve for v_f and substitute for the magnitude of the acceleration from Equation 23.12:

$$v_f = \sqrt{2ad} = \sqrt{2\left(\frac{qE}{m}\right)d} = \sqrt{\frac{2qEd}{m}}$$

(B) Find the speed of the particle at $\textcircled{\text{B}}$ by modeling it as a nonisolated system in terms of energy.

SOLUTION

Categorize The problem statement tells us that the charge is a *nonisolated system for energy*. The electric force, like any force, can do work on a system. Energy is transferred to the system of the charge by work done by the electric force exerted on the charge. The initial configuration of the system is when the particle is at rest at $\textcircled{\text{A}}$, and the final configuration is when it is moving with some speed at $\textcircled{\text{B}}$.

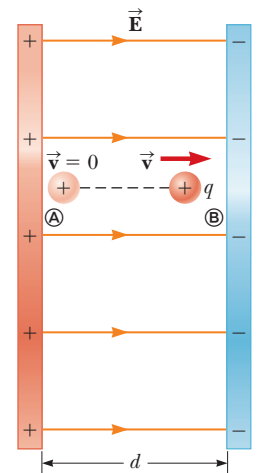

Figure 23.23 (Example 23.10) A positive point charge q in a uniform electric field $\vec{\mathbf{E}}$ undergoes constant acceleration in the direction of the field.

continued

23.10 continued

Analyze Write the appropriate reduction of the conservation of energy equation, Equation 8.2, for the system of the charged particle:

$$W = \Delta K$$

Replace the work and kinetic energies with values appropriate for this situation:

$$F_e \Delta x = K_{\text{Ⓢ}} - K_{\text{ⓐ}} = \frac{1}{2} m v_f^2 - 0 \rightarrow v_f = \sqrt{\frac{2F_e \Delta x}{m}}$$

Substitute for the magnitude of the electric force F_e from the particle in a field model and the displacement Δx :

$$v_f = \sqrt{\frac{2(qE)(d)}{m}} = \sqrt{\frac{2qEd}{m}}$$

Finalize The answer to part (B) is the same as that for part (A), as we expect. This problem can be solved with different approaches. We saw the same possibilities with mechanical problems.

Example 23.11 An Accelerated Electron AM

An electron enters the region of a uniform electric field as shown in Figure 23.24, with $v_i = 3.00 \times 10^6$ m/s and $E = 200$ N/C. The horizontal length of the plates is $\ell = 0.100$ m.

(A) Find the acceleration of the electron while it is in the electric field.

SOLUTION

Conceptualize This example differs from the preceding one because the velocity of the charged particle is initially perpendicular to the electric field lines. (In Example 23.10, the velocity of the charged particle is always parallel to the electric field lines.) As a result, the electron in this example follows a curved path as shown in Figure 23.24. The motion of the electron is the same as that of a massive particle projected horizontally in a gravitational field near the surface of the Earth.

Categorize The electron is a *particle in a field (electric)*. Because the electric field is uniform, a constant electric force is exerted on the electron. To find the acceleration of the electron, we can model it as a *particle under a net force*.

Analyze From the particle in a field model, we know that the direction of the electric force on the electron is downward in Figure 23.24, opposite the direction of the electric field lines. From the particle under a net force model, therefore, the acceleration of the electron is downward.

The particle under a net force model was used to develop Equation 23.12 in the case in which the electric force on a particle is the only force. Use this equation to evaluate the y component of the acceleration of the electron:

$$a_y = -\frac{eE}{m_e}$$

Substitute numerical values:

$$a_y = -\frac{(1.60 \times 10^{-19} \text{ C})(200 \text{ N/C})}{9.11 \times 10^{-31} \text{ kg}} = -3.51 \times 10^{13} \text{ m/s}^2$$

(B) Assuming the electron enters the field at time $t = 0$, find the time at which it leaves the field.

SOLUTION

Categorize Because the electric force acts only in the vertical direction in Figure 23.24, the motion of the particle in the horizontal direction can be analyzed by modeling it as a *particle under constant velocity*.

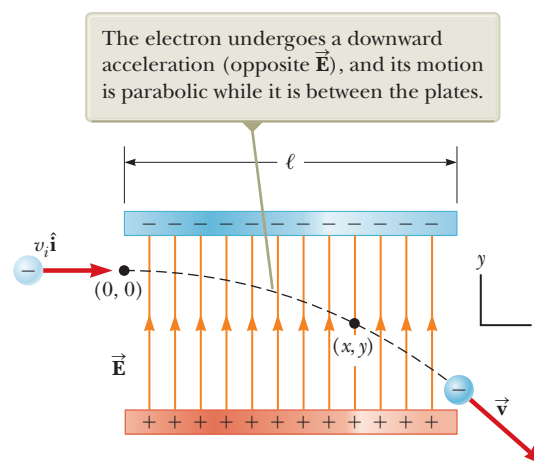

Figure 23.24 (Example 23.11) An electron is projected horizontally into a uniform electric field produced by two charged plates.

► 23.11 continued

Analyze Solve Equation 2.7 for the time at which the electron arrives at the right edges of the plates:

$$x_f = x_i + v_x t \rightarrow t = \frac{x_f - x_i}{v_x}$$

Substitute numerical values:

$$t = \frac{\ell - 0}{v_x} = \frac{0.100 \text{ m}}{3.00 \times 10^6 \text{ m/s}} = 3.33 \times 10^{-8} \text{ s}$$

(C) Assuming the vertical position of the electron as it enters the field is $y_i = 0$, what is its vertical position when it leaves the field?

SOLUTION

Categorize Because the electric force is constant in Figure 23.24, the motion of the particle in the vertical direction can be analyzed by modeling it as a *particle under constant acceleration*.

Analyze Use Equation 2.16 to describe the position of the particle at any time t :

$$y_f = y_i + v_{yi}t + \frac{1}{2}a_y t^2$$

Substitute numerical values:

$$\begin{aligned} y_f &= 0 + 0 + \frac{1}{2}(-3.51 \times 10^{13} \text{ m/s}^2)(3.33 \times 10^{-8} \text{ s})^2 \\ &= -0.0195 \text{ m} = -1.95 \text{ cm} \end{aligned}$$

Finalize If the electron enters just below the negative plate in Figure 23.24 and the separation between the plates is less than the value just calculated, the electron will strike the positive plate.

Notice that we have used *four* analysis models to describe the electron in the various parts of this problem. We have neglected the gravitational force acting on the electron, which represents a good approximation when dealing with atomic particles. For an electric field of 200 N/C, the ratio of the magnitude of the electric force eE to the magnitude of the gravitational force mg is on the order of 10^{12} for an electron and on the order of 10^9 for a proton.

Summary

Definitions

■ The **electric field** $\vec{\mathbf{E}}$ at some point in space is defined as the electric force $\vec{\mathbf{F}}_e$ that acts on a small positive test charge placed at that point divided by the magnitude q_0 of the test charge:

$$\vec{\mathbf{E}} \equiv \frac{\vec{\mathbf{F}}_e}{q_0} \quad (23.7)$$

Concepts and Principles

■ **Electric charges** have the following important properties:

- Charges of opposite sign attract one another, and charges of the same sign repel one another.
- The total charge in an isolated system is conserved.
- Charge is quantized.

■ **Conductors** are materials in which electrons move freely. **Insulators** are materials in which electrons do not move freely.

continued

Coulomb's law states that the electric force exerted by a point charge q_1 on a second point charge q_2 is

$$\vec{\mathbf{F}}_{12} = k_e \frac{q_1 q_2}{r^2} \hat{\mathbf{r}}_{12} \quad (23.6)$$

where r is the distance between the two charges and $\hat{\mathbf{r}}_{12}$ is a unit vector directed from q_1 toward q_2 . The constant k_e , which is called the **Coulomb constant**, has the value $k_e = 8.988 \times 10^9 \text{ N} \cdot \text{m}^2/\text{C}^2$.

The electric field due to a group of point charges can be obtained by using the superposition principle. That is, the total electric field at some point equals the vector sum of the electric fields of all the charges:

$$\vec{\mathbf{E}} = k_e \sum_i \frac{q_i}{r_i^2} \hat{\mathbf{r}}_i \quad (23.10)$$

At a distance r from a point charge q , the electric field due to the charge is

$$\vec{\mathbf{E}} = k_e \frac{q}{r^2} \hat{\mathbf{r}} \quad (23.9)$$

where $\hat{\mathbf{r}}$ is a unit vector directed from the charge toward the point in question. The electric field is directed radially outward from a positive charge and radially inward toward a negative charge.

The electric field at some point due to a continuous charge distribution is

$$\vec{\mathbf{E}} = k_e \int \frac{dq}{r^2} \hat{\mathbf{r}} \quad (23.11)$$

where dq is the charge on one element of the charge distribution and r is the distance from the element to the point in question.

Analysis Models for Problem Solving

Particle in a Field (Electric) A source particle with some electric charge establishes an **electric field** $\vec{\mathbf{E}}$ throughout space. When a particle with charge q is placed in that field, it experiences an electric force given by

$$\vec{\mathbf{F}}_e = q\vec{\mathbf{E}} \quad (23.8)$$

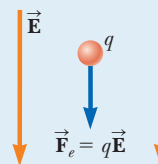

Objective Questions

1. denotes answer available in *Student Solutions Manual/Study Guide*

1. A free electron and a free proton are released in identical electric fields. (i) How do the magnitudes of the electric force exerted on the two particles compare? (a) It is millions of times greater for the electron. (b) It is thousands of times greater for the electron. (c) They are equal. (d) It is thousands of times smaller for the electron. (e) It is millions of times smaller for the electron. (ii) Compare the magnitudes of their accelerations. Choose from the same possibilities as in part (i).
2. What prevents gravity from pulling you through the ground to the center of the Earth? Choose the best answer. (a) The density of matter is too great. (b) The positive nuclei of your body's atoms repel the positive nuclei of the atoms of the ground. (c) The density of the ground is greater than the density of your body. (d) Atoms are bound together by chemical bonds. (e) Electrons on the ground's surface and the surface of your feet repel one another.
3. A very small ball has a mass of $5.00 \times 10^{-3} \text{ kg}$ and a charge of $4.00 \mu\text{C}$. What magnitude electric field directed upward will balance the weight of the ball so that the ball is suspended motionless above the ground? (a) $8.21 \times 10^2 \text{ N/C}$ (b) $1.22 \times 10^4 \text{ N/C}$ (c) $2.00 \times 10^{-2} \text{ N/C}$ (d) $5.11 \times 10^6 \text{ N/C}$ (e) $3.72 \times 10^3 \text{ N/C}$
4. An electron with a speed of $3.00 \times 10^6 \text{ m/s}$ moves into a uniform electric field of magnitude $1.00 \times 10^3 \text{ N/C}$.

- The field lines are parallel to the electron's velocity and pointing in the same direction as the velocity. How far does the electron travel before it is brought to rest? (a) 2.56 cm (b) 5.12 cm (c) 11.2 cm (d) 3.34 m (e) 4.24 m
5. A point charge of -4.00 nC is located at $(0, 1.00) \text{ m}$. What is the x component of the electric field due to the point charge at $(4.00, -2.00) \text{ m}$? (a) 1.15 N/C (b) -0.864 N/C (c) 1.44 N/C (d) -1.15 N/C (e) 0.864 N/C
 6. A circular ring of charge with radius b has total charge q uniformly distributed around it. What is the magnitude of the electric field at the center of the ring? (a) 0 (b) $k_e q/b^2$ (c) $k_e q^2/b^2$ (d) $k_e q^2/b$ (e) none of those answers
 7. What happens when a charged insulator is placed near an uncharged metallic object? (a) They repel each other. (b) They attract each other. (c) They may attract or repel each other, depending on whether the charge on the insulator is positive or negative. (d) They exert no electrostatic force on each other. (e) The charged insulator always spontaneously discharges.
 8. Estimate the magnitude of the electric field due to the proton in a hydrogen atom at a distance of $5.29 \times 10^{-11} \text{ m}$, the expected position of the electron in the atom. (a) 10^{-11} N/C (b) 10^8 N/C (c) 10^{14} N/C (d) 10^6 N/C (e) 10^{12} N/C

9. (i) A metallic coin is given a positive electric charge. Does its mass (a) increase measurably, (b) increase by an amount too small to measure directly, (c) remain unchanged, (d) decrease by an amount too small to measure directly, or (e) decrease measurably? (ii) Now the coin is given a negative electric charge. What happens to its mass? Choose from the same possibilities as in part (i).
10. Assume the charged objects in Figure OQ23.10 are fixed. Notice that there is no sight line from the location of q_2 to the location of q_1 . If you were at q_1 , you would be unable to see q_2 because it is behind q_3 . How would you calculate the electric force exerted on the object with charge q_1 ? (a) Find only the force exerted by q_2 on charge q_1 . (b) Find only the force exerted by q_3 on charge q_1 . (c) Add the force that q_2 would exert by itself on charge q_1 to the force that q_3 would exert by itself on charge q_1 . (d) Add the force that q_3 would exert by itself to a certain fraction of the force that q_2 would exert by itself. (e) There is no definite way to find the force on charge q_1 .

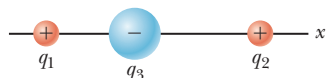

Figure OQ23.10

11. Three charged particles are arranged on corners of a square as shown in Figure OQ23.11, with charge $-Q$ on both the particle at the upper left corner and the particle at the lower right corner and with charge $+2Q$ on the particle at the lower left corner.

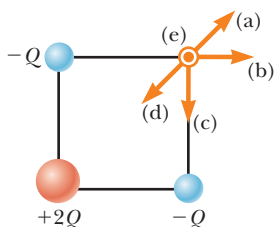

Figure OQ23.11

- (i) What is the direction of the electric field at the upper right corner, which is a point in empty space? (a) It is upward and to the right. (b) It is straight to the right. (c) It is straight downward. (d) It is downward and to the left. (e) It is perpendicular to the plane of the picture and outward. (ii) Suppose the $+2Q$ charge at the lower left corner is removed. Then does the magnitude of the field at the upper right corner (a) become larger, (b) become smaller, (c) stay the same, or (d) change unpredictably?

12. Two point charges attract each other with an electric force of magnitude F . If the charge on one of the particles is reduced to one-third its original value and the distance between the particles is doubled, what is the resulting magnitude of the electric force between them? (a) $\frac{1}{12}F$ (b) $\frac{1}{3}F$ (c) $\frac{1}{6}F$ (d) $\frac{3}{4}F$ (e) $\frac{3}{2}F$
13. Assume a uniformly charged ring of radius R and charge Q produces an electric field E_{ring} at a point P on its axis, at distance x away from the center of the ring as in Figure OQ23.13a. Now the same charge Q is spread uniformly over the circular area the ring encloses, forming a flat disk of charge with the same radius as in Figure OQ23.13b. How does the field E_{disk} produced by the disk at P compare with the field produced by the ring at the same point? (a) $E_{\text{disk}} < E_{\text{ring}}$ (b) $E_{\text{disk}} = E_{\text{ring}}$ (c) $E_{\text{disk}} > E_{\text{ring}}$ (d) impossible to determine

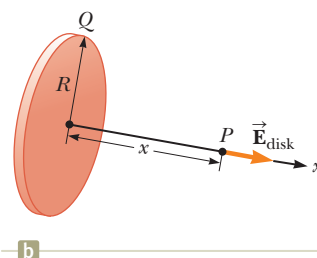
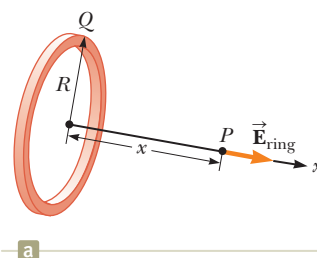

Figure OQ23.13

14. An object with negative charge is placed in a region of space where the electric field is directed vertically upward. What is the direction of the electric force exerted on this charge? (a) It is up. (b) It is down. (c) There is no force. (d) The force can be in any direction.
15. The magnitude of the electric force between two protons is 2.30×10^{-26} N. How far apart are they? (a) 0.100 m (b) 0.022 0 m (c) 3.10 m (d) 0.005 70 m (e) 0.480 m

Conceptual Questions

1. denotes answer available in *Student Solutions Manual/Study Guide*

- 1.** (a) Would life be different if the electron were positively charged and the proton were negatively charged? (b) Does the choice of signs have any bearing on physical and chemical interactions? Explain your answers.
2. A charged comb often attracts small bits of dry paper that then fly away when they touch the comb. Explain why that occurs.
3. A person is placed in a large, hollow, metallic sphere that is insulated from ground. If a large charge is placed

on the sphere, will the person be harmed upon touching the inside of the sphere?

4. A student who grew up in a tropical country and is studying in the United States may have no experience with static electricity sparks and shocks until his or her first American winter. Explain.
5. If a suspended object A is attracted to a charged object B, can we conclude that A is charged? Explain.

6. Consider point A in Figure CQ23.6 located an arbitrary distance from two positive point charges in otherwise empty space. (a) Is it possible for an electric field to exist at point A in empty space? Explain. (b) Does charge exist at this point? Explain. (c) Does a force exist at this point? Explain.

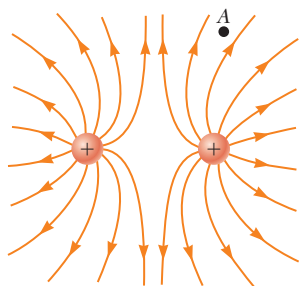

Figure CQ23.6

7. In fair weather, there is an electric field at the surface of the Earth, pointing down into the ground. What is the sign of the electric charge on the ground in this situation?

8. Why must hospital personnel wear special conducting shoes while working around oxygen in an operating room? What might happen if the personnel wore shoes with rubber soles?

9. A balloon clings to a wall after it is negatively charged by rubbing. (a) Does that occur because the wall is positively charged? (b) Why does the balloon eventually fall?

10. Consider two electric dipoles in empty space. Each dipole has zero net charge. (a) Does an electric force exist between the dipoles; that is, can two objects with zero net charge exert electric forces on each other? (b) If so, is the force one of attraction or of repulsion?

11. A glass object receives a positive charge by rubbing it with a silk cloth. In the rubbing process, have protons been added to the object or have electrons been removed from it?

Problems

WebAssign The problems found in this chapter may be assigned online in Enhanced WebAssign

1. straightforward; 2. intermediate; 3. challenging

1. full solution available in the *Student Solutions Manual/Study Guide*

AMT Analysis Model tutorial available in Enhanced WebAssign

GP Guided Problem

M Master It tutorial available in Enhanced WebAssign

W Watch It video solution available in Enhanced WebAssign

Section 23.1 Properties of Electric Charges

1. Find to three significant digits the charge and the mass of the following particles. *Suggestion:* Begin by looking up the mass of a neutral atom on the periodic table of the elements in Appendix C. (a) an ionized hydrogen atom, represented as H^+ (b) a singly ionized sodium atom, Na^+ (c) a chloride ion Cl^- (d) a doubly ionized calcium atom, $Ca^{++} = Ca^{2+}$ (e) the center of an ammonia molecule, modeled as an N^{3-} ion (f) quadruply ionized nitrogen atoms, N^{4+} , found in plasma in a hot star (g) the nucleus of a nitrogen atom (h) the molecular ion H_2O^-
2. (a) Calculate the number of electrons in a small, electrically neutral silver pin that has a mass of 10.0 g. Silver has 47 electrons per atom, and its molar mass is 107.87 g/mol. (b) Imagine adding electrons to the pin until the negative charge has the very large value 1.00 mC. How many electrons are added for every 10^9 electrons already present?

Section 23.2 Charging Objects by Induction

Section 23.3 Coulomb's Law

3. Two protons in an atomic nucleus are typically separated by a distance of 2×10^{-15} m. The electric repulsive force between the protons is huge, but the attractive nuclear force is even stronger and keeps the nucleus from bursting apart. What is the magnitude of the electric force between two protons separated by 2.00×10^{-15} m?

4. A charged particle A exerts a force of $2.62 \mu N$ to the right on charged particle B when the particles are 13.7 mm apart. Particle B moves straight away from A to make the distance between them 17.7 mm. What vector force does it then exert on A ?

5. In a thundercloud, there may be electric charges of $+40.0$ C near the top of the cloud and -40.0 C near the bottom of the cloud. These charges are separated by 2.00 km. What is the electric force on the top charge?

6. (a) Find the magnitude of the electric force between a Na^+ ion and a Cl^- ion separated by 0.50 nm. (b) Would the answer change if the sodium ion were replaced by Li^+ and the chloride ion by Br^- ? Explain.

7. **Review.** A molecule of DNA (deoxyribonucleic acid) is $2.17 \mu m$ long. The ends of the molecule become singly ionized: negative on one end, positive on the other. The helical molecule acts like a spring and compresses 1.00% upon becoming charged. Determine the effective spring constant of the molecule.

8. Nobel laureate Richard Feynman (1918–1988) once said that if two persons stood at arm's length from each other and each person had 1% more electrons than protons, the force of repulsion between them would be enough to lift a "weight" equal to that of the entire Earth. Carry out an order-of-magnitude calculation to substantiate this assertion.

9. A 7.50 -nC point charge is located 1.80 m from a 4.20 -nC point charge. (a) Find the magnitude of the

electric force that one particle exerts on the other.
 (b) Is the force attractive or repulsive?

- 10.** (a) Two protons in a molecule are 3.80×10^{-10} m apart. Find the magnitude of the electric force exerted by one proton on the other. (b) State how the magnitude of this force compares with the magnitude of the gravitational force exerted by one proton on the other. (c) **What If?** What must be a particle's charge-to-mass ratio if the magnitude of the gravitational force between two of these particles is equal to the magnitude of electric force between them?

- 11.** Three point charges are arranged as shown in Figure P23.11. Find (a) the magnitude and (b) the direction of the electric force on the particle at the origin.

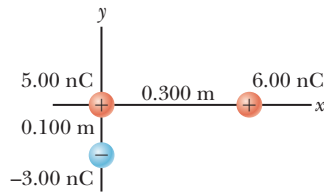

Figure P23.11 Problems 11 and 35.

- 12.** Three point charges lie along a straight line as shown in Figure P23.12, where $q_1 = 6.00 \mu\text{C}$, $q_2 = 1.50 \mu\text{C}$, and $q_3 = -2.00 \mu\text{C}$. The separation distances are $d_1 = 3.00$ cm and $d_2 = 2.00$ cm. Calculate the magnitude and direction of the net electric force on (a) q_1 , (b) q_2 , and (c) q_3 .

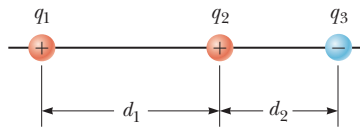

Figure P23.12

- 13.** Two small beads having positive charges $q_1 = 3q$ and $q_2 = q$ are fixed at the opposite ends of a horizontal insulating rod of length $d = 1.50$ m. The bead with charge q_1 is at the origin. As shown in Figure P23.13, a third small, charged bead is free to slide on the rod. (a) At what position x is the third bead in equilibrium? (b) Can the equilibrium be stable?

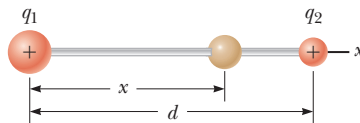

Figure P23.13 Problems 13 and 14.

- 14.** Two small beads having charges q_1 and q_2 of the same sign are fixed at the opposite ends of a horizontal insulating rod of length d . The bead with charge q_1 is at the origin. As shown in Figure P23.13, a third small, charged bead is free to slide on the rod. (a) At what position x is the third bead in equilibrium? (b) Can the equilibrium be stable?

- 15.** Three charged particles are located at the corners of an equilateral triangle as shown in Figure P23.15. Calculate the total electric force on the $7.00\text{-}\mu\text{C}$ charge.

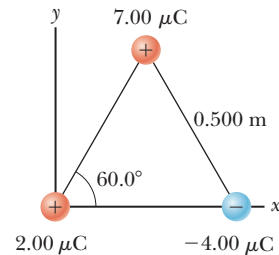

Figure P23.15 Problems 15 and 30.

- 16.** Two small metallic spheres, each of mass $m = 0.200$ g, are suspended as pendulums by light strings of length L as shown in Figure P23.16. The spheres are given the same electric charge of 7.2 nC, and they come to equilibrium when each string is at an angle of $\theta = 5.00^\circ$ with the vertical. How long are the strings?

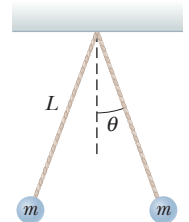

Figure P23.16

- 17. Review.** In the Bohr theory of the hydrogen atom, an electron moves in a circular orbit about a proton, where the radius of the orbit is 5.29×10^{-11} m. (a) Find the magnitude of the electric force exerted on each particle. (b) If this force causes the centripetal acceleration of the electron, what is the speed of the electron?
- 18.** Particle A of charge 3.00×10^{-4} C is at the origin, particle B of charge -6.00×10^{-4} C is at $(4.00 \text{ m}, 0)$, and particle C of charge 1.00×10^{-4} C is at $(0, 3.00 \text{ m})$. We wish to find the net electric force on C. (a) What is the x component of the electric force exerted by A on C? (b) What is the y component of the force exerted by A on C? (c) Find the magnitude of the force exerted by B on C. (d) Calculate the x component of the force exerted by B on C. (e) Calculate the y component of the force exerted by B on C. (f) Sum the two x components from parts (a) and (d) to obtain the resultant x component of the electric force acting on C. (g) Similarly, find the y component of the resultant force vector acting on C. (h) Find the magnitude and direction of the resultant electric force acting on C.

- 19.** A point charge $+2Q$ is at the origin and a point charge $-Q$ is located along the x axis at $x = d$ as in Figure P23.19. Find a symbolic expression for the net force on a third point charge $+Q$ located along the y axis at $y = d$.

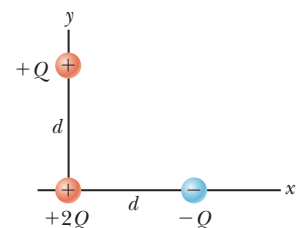

Figure P23.19

- 20. Review.** Two identical particles, each having charge $+q$, are fixed in space and separated by a distance d . A third particle with charge $-Q$ is free to move and lies initially at rest on the

perpendicular bisector of the two fixed charges a distance x from the midpoint between those charges (Fig. P23.20). (a) Show that if x is small compared with d , the motion of $-Q$ is simple harmonic along the perpendicular bisector. (b) Determine the period of that motion. (c) How fast will the charge $-Q$ be moving when it is at the midpoint between the two fixed charges if initially it is released at a distance $a \ll d$ from the midpoint?

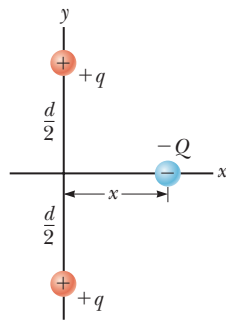

Figure P23.20

- 21.** Two identical conducting small spheres are placed with their centers 0.300 m apart. One is given a charge of 12.0 nC and the other a charge of -18.0 nC. (a) Find the electric force exerted by one sphere on the other. (b) **What If?** The spheres are connected by a conducting wire. Find the electric force each exerts on the other after they have come to equilibrium.
- 22.** Why is the following situation impossible? Two identical dust particles of mass $1.00 \mu\text{g}$ are floating in empty space, far from any external sources of large gravitational or electric fields, and at rest with respect to each other. Both particles carry electric charges that are identical in magnitude and sign. The gravitational and electric forces between the particles happen to have the same magnitude, so each particle experiences zero net force and the distance between the particles remains constant.

Section 23.4 Analysis Model: Particle in a Field (Electric)

- 23.** What are the magnitude and direction of the electric field that will balance the weight of (a) an electron and (b) a proton? (You may use the data in Table 23.1.)
- 24.** A small object of mass 3.80 g and charge $-18.0 \mu\text{C}$ is suspended motionless above the ground when immersed in a uniform electric field perpendicular to the ground. What are the magnitude and direction of the electric field?
- 25.** Four charged particles are at the corners of a square of side a as shown in Figure P23.25. Determine (a) the electric field at the location of charge q and (b) the total electric force exerted on q .

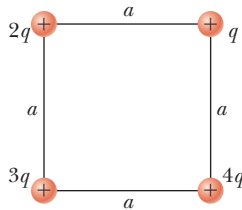

Figure P23.25

- 26.** Three point charges lie along a circle of radius r at angles of 30° , 150° , and 270° as shown in Figure P23.26. Find a symbolic expression for the resultant electric field at the center of the circle.

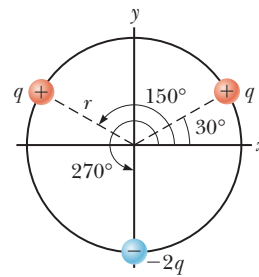

Figure P23.26

- 27.** Two equal positively charged particles are at opposite corners of a trapezoid as shown in Figure P23.27. Find symbolic expressions for the total electric field at (a) the point P and (b) the point P' .

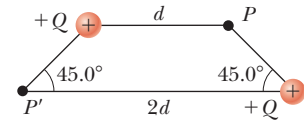

Figure P23.27

- 28.** Consider n equal positively charged particles each of magnitude Q/n placed symmetrically around a circle of radius a . (a) Calculate the magnitude of the electric field at a point a distance x from the center of the circle and on the line passing through the center and perpendicular to the plane of the circle. (b) Explain why this result is identical to the result of the calculation done in Example 23.8.

- 29.** In Figure P23.29, determine the point (other than infinity) at which the electric field is zero.

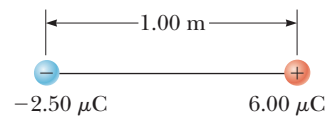

Figure P23.29

- 30.** Three charged particles are at the corners of an equilateral triangle as shown in Figure P23.15. (a) Calculate the electric field at the position of the $2.00\text{-}\mu\text{C}$ charge due to the $7.00\text{-}\mu\text{C}$ and $-4.00\text{-}\mu\text{C}$ charges. (b) Use your answer to part (a) to determine the force on the $2.00\text{-}\mu\text{C}$ charge.
- 31.** Three point charges are located on a circular arc as shown in Figure P23.31. (a) What is the total electric field at P , the center of the arc? (b) Find the electric force that would be exerted on a -5.00-nC point charge placed at P .

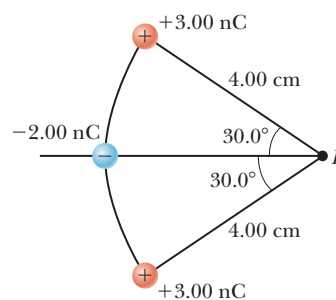

Figure P23.31

32. Two charged particles are located on the x -axis. The first is a charge $+Q$ at $x = -a$. The second is an unknown charge located at $x = +3a$. The net electric field these charges produce at the origin has a magnitude of $2k_e Q/a^2$. Explain how many values are possible for the unknown charge and find the possible values.
33. A small, 2.00-g plastic ball is suspended by a 20.0-cm-long string in a uniform electric field as shown in Figure P23.33. If the ball is in equilibrium when the string makes a 15.0° angle with the vertical, what is the net charge on the ball?

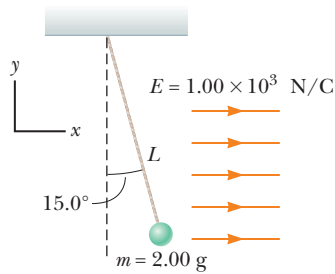

Figure P23.33

34. Two $2.00\text{-}\mu\text{C}$ point charges are located on the x axis. One is at $x = 1.00$ m, and the other is at $x = -1.00$ m. (a) Determine the electric field on the y axis at $y = 0.500$ m. (b) Calculate the electric force on a $-3.00\text{-}\mu\text{C}$ charge placed on the y axis at $y = 0.500$ m.
35. Three point charges are arranged as shown in Figure P23.11. (a) Find the vector electric field that the 6.00-nC and -3.00-nC charges together create at the origin. (b) Find the vector force on the 5.00-nC charge.
36. Consider the electric dipole shown in Figure P23.36. Show that the electric field at a distant point on the $+x$ axis is $E_x \approx 4k_e qa/x^3$.

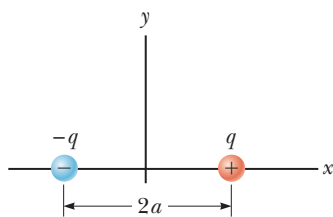

Figure P23.36

Section 23.5 Electric Field of a Continuous Charge Distribution

37. A rod 14.0 cm long is uniformly charged and has a total charge of $-22.0\text{ }\mu\text{C}$. Determine (a) the magnitude and (b) the direction of the electric field along the axis of the rod at a point 36.0 cm from its center.
38. A uniformly charged disk of radius 35.0 cm carries charge with a density of $7.90 \times 10^{-3}\text{ C/m}^2$. Calculate the electric field on the axis of the disk at (a) 5.00 cm, (b) 10.0 cm, (c) 50.0 cm, and (d) 200 cm from the center of the disk.
39. A uniformly charged ring of radius 10.0 cm has a total charge of $75.0\text{ }\mu\text{C}$. Find the electric field on the axis of

the ring at (a) 1.00 cm, (b) 5.00 cm, (c) 30.0 cm, and (d) 100 cm from the center of the ring.

40. The electric field along the axis of a uniformly charged disk of radius R and total charge Q was calculated in Example 23.9. Show that the electric field at distances x that are large compared with R approaches that of a particle with charge $Q = \sigma\pi R^2$. *Suggestion:* First show that $x/(x^2 + R^2)^{1/2} = (1 + R^2/x^2)^{-1/2}$ and use the binomial expansion $(1 + \delta)^n \approx 1 + n\delta$, when $\delta \ll 1$.
41. Example 23.9 derives the exact expression for the electric field at a point on the axis of a uniformly charged disk. Consider a disk of radius $R = 3.00$ cm having a uniformly distributed charge of $+5.20\text{ }\mu\text{C}$. (a) Using the result of Example 23.9, compute the electric field at a point on the axis and 3.00 mm from the center. (b) **What If?** Explain how the answer to part (a) compares with the field computed from the near-field approximation $E = \sigma/2\epsilon_0$. (We derived this expression in Example 23.9.) (c) Using the result of Example 23.9, compute the electric field at a point on the axis and 30.0 cm from the center of the disk. (d) **What If?** Explain how the answer to part (c) compares with the electric field obtained by treating the disk as a $+5.20\text{-}\mu\text{C}$ charged particle at a distance of 30.0 cm.

42. A uniformly charged rod of length L and total charge Q lies along the x axis as shown in Figure P23.42. (a) Find the components of the electric field at the point P on the y axis a distance d from the origin. (b) What are the approximate values of the field components when $d \gg L$? Explain why you would expect these results.

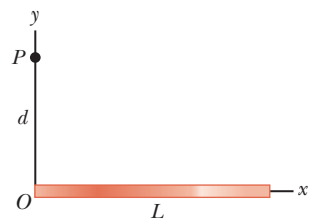

Figure P23.42

43. A continuous line of charge lies along the x axis, extending from $x = +x_0$ to positive infinity. The line carries positive charge with a uniform linear charge density λ_0 . What are (a) the magnitude and (b) the direction of the electric field at the origin?
44. A thin rod of length ℓ and uniform charge per unit length λ lies along the x axis as shown in Figure P23.44. (a) Show that the electric field at P , a distance d from the rod along its perpendicular bisector, has no x

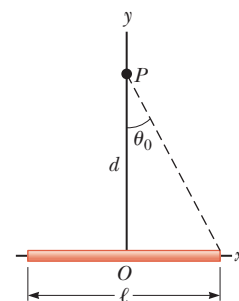

Figure P23.44

component and is given by $E = 2k_e \lambda \sin \theta_0 / d$. (b) **What If?** Using your result to part (a), show that the field of a rod of infinite length is $E = 2k_e \lambda / d$.

45. A uniformly charged insulating rod of length 14.0 cm is bent into the shape of a semicircle as shown in Figure P23.45. The rod has a total charge of $-7.50 \mu\text{C}$. Find (a) the magnitude and (b) the direction of the electric field at O , the center of the semicircle.



Figure P23.45

46. (a) Consider a uniformly charged, thin-walled, right circular cylindrical shell having total charge Q , radius R , and length ℓ . Determine the electric field at a point a distance d from the right side of the cylinder as shown in Figure P23.46. *Suggestion:* Use the result of Example 23.8 and treat the cylinder as a collection of ring charges. (b) **What If?** Consider now a solid cylinder with the same dimensions and carrying the same charge, uniformly distributed through its volume. Use the result of Example 23.9 to find the field it creates at the same point.

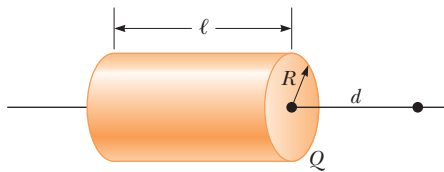

Figure P23.46

Section 23.6 Electric Field Lines

47. A negatively charged rod of finite length carries charge with a uniform charge per unit length. Sketch the electric field lines in a plane containing the rod.
48. A positively charged disk has a uniform charge per unit area σ as described in Example 23.9. Sketch the electric field lines in a plane perpendicular to the plane of the disk passing through its center.

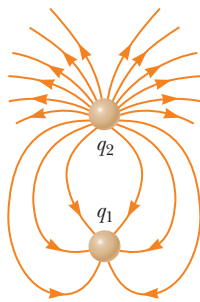

Figure P23.49

49. Figure P23.49 shows the electric field lines for two charged particles separated by a small distance. (a) Determine the ratio q_1/q_2 . (b) What are the signs of q_1 and q_2 ?

50. Three equal positive charges q are at the corners of an equilateral triangle of side a as shown in Figure P23.50. Assume the three charges together create an electric field. (a) Sketch the field lines in the plane of the charges. (b) Find the location of one point (other than ∞) where the electric field is zero. What are (c) the magnitude and (d) the direction of the electric field at P due to the two charges at the base?

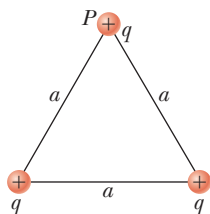

Figure P23.50

Section 23.7 Motion of a Charged Particle in a Uniform Electric Field

51. A proton accelerates from rest in a uniform electric field of 640 N/C . At one later moment, its speed is 1.20 Mm/s (nonrelativistic because v is much less than the speed of light). (a) Find the acceleration of the proton. (b) Over what time interval does the proton reach this speed? (c) How far does it move in this time interval? (d) What is its kinetic energy at the end of this interval?

52. A proton is projected in the positive x direction into a region of a uniform electric field $\vec{E} = (-6.00 \times 10^5) \hat{i} \text{ N/C}$ at $t = 0$. The proton travels 7.00 cm as it comes to rest. Determine (a) the acceleration of the proton, (b) its initial speed, and (c) the time interval over which the proton comes to rest.

53. An electron and a proton are each placed at rest in a uniform electric field of magnitude 520 N/C . Calculate the speed of each particle 48.0 ns after being released.

54. Protons are projected with an initial speed $v_i = 9.55 \text{ km/s}$ from a field-free region through a plane and into a region where a uniform electric field $\vec{E} = -720 \hat{j} \text{ N/C}$ is present above the plane as shown in Figure P23.54. The initial velocity vector of the protons makes an angle θ with the plane. The protons are to hit a target that lies at a horizontal distance of $R = 1.27 \text{ mm}$ from the point where the protons cross the plane and enter the electric field. We wish to find the angle θ at which the protons must pass through the plane to strike the target. (a) What analysis model describes the horizontal motion of the protons above the plane? (b) What analysis model describes the vertical motion of the protons above the plane? (c) Argue that Equation 4.13 would be applicable to the protons in this situation. (d) Use Equation 4.13 to write an expression for R in terms of v_i , E , the charge and mass of the proton, and the angle θ . (e) Find the two possible values of the angle θ . (f) Find the time interval during which the proton is above the plane in Figure P23.54 for each of the two possible values of θ .

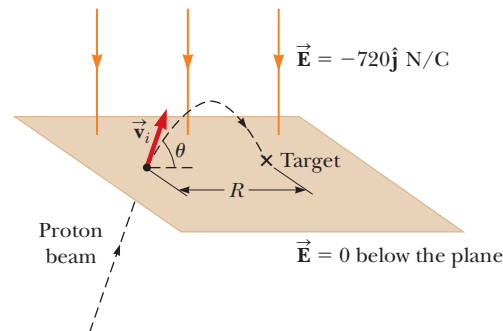

Figure P23.54

55. The electrons in a particle beam each have a kinetic energy K . What are (a) the magnitude and (b) the direction of the electric field that will stop these electrons in a distance d ?

56. Two horizontal metal plates, each 10.0 cm square, are aligned 1.00 cm apart with one above the other. They are given equal-magnitude charges of opposite sign so that a uniform downward electric field of 2.00×10^3 N/C exists in the region between them. A particle of mass 2.00×10^{-16} kg and with a positive charge of 1.00×10^{-6} C leaves the center of the bottom negative plate with an initial speed of 1.00×10^5 m/s at an angle of 37.0° above the horizontal. (a) Describe the trajectory of the particle. (b) Which plate does it strike? (c) Where does it strike, relative to its starting point?
57. **M** A proton moves at 4.50×10^5 m/s in the horizontal direction. It enters a uniform vertical electric field with a magnitude of 9.60×10^3 N/C. Ignoring any gravitational effects, find (a) the time interval required for the proton to travel 5.00 cm horizontally, (b) its vertical displacement during the time interval in which it travels 5.00 cm horizontally, and (c) the horizontal and vertical components of its velocity after it has traveled 5.00 cm horizontally.

Additional Problems

58. Three solid plastic cylinders all have radius 2.50 cm and length 6.00 cm. Find the charge of each cylinder given the following additional information about each one. Cylinder (a) carries charge with uniform density 15.0 nC/m² everywhere on its surface. Cylinder (b) carries charge with uniform density 15.0 nC/m² on its curved lateral surface only. Cylinder (c) carries charge with uniform density 500 nC/m³ throughout the plastic.
59. Consider an infinite number of identical particles, each with charge q , placed along the x axis at distances $a, 2a, 3a, 4a, \dots$ from the origin. What is the electric field at the origin due to this distribution? *Suggestion:* Use

$$1 + \frac{1}{2^2} + \frac{1}{3^2} + \frac{1}{4^2} + \dots = \frac{\pi^2}{6}$$

60. A particle with charge -3.00 nC is at the origin, and a particle with negative charge of magnitude Q is at $x = 50.0$ cm. A third particle with a positive charge is in equilibrium at $x = 20.9$ cm. What is Q ?

61. **AMT** A small block of mass m and charge Q is placed on an insulated, frictionless, inclined plane of angle θ as in Figure P23.61. An electric field is applied parallel to the incline. (a) Find an expression for the magnitude of the electric field that enables the block to remain at rest. (b) If $m = 5.40$ g, $Q = -7.00$ μ C, and $\theta = 25.0^\circ$, determine the magnitude and the direction of the electric field that enables the block to remain at rest on the incline.

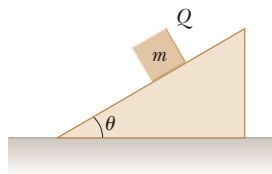

Figure P23.61

62. A small sphere of charge $q_1 = 0.800$ μ C hangs from the end of a spring as in Figure P23.62a. When another small sphere of charge $q_2 = -0.600$ μ C is held beneath

the first sphere as in Figure P23.62b, the spring stretches by $d = 3.50$ cm from its original length and reaches a new equilibrium position with a separation between the charges of $r = 5.00$ cm. What is the force constant of the spring?

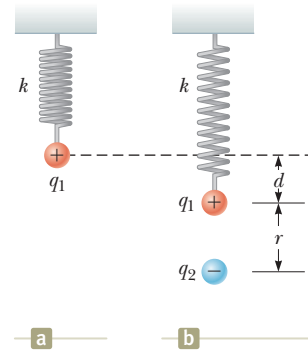

Figure P23.62

63. A line of charge starts at $x = +x_0$ and extends to positive infinity. The linear charge density is $\lambda = \lambda_0 x_0/x$, where λ_0 is a constant. Determine the electric field at the origin.
64. A small sphere of mass $m = 7.50$ g and charge $q_1 = 32.0$ nC is attached to the end of a string and hangs vertically as in Figure P23.64. A second charge of equal mass and charge $q_2 = -58.0$ nC is located below the first charge a distance $d = 2.00$ cm below the first charge as in Figure P23.64. (a) Find the tension in the string. (b) If the string can withstand a maximum tension of 0.180 N, what is the smallest value d can have before the string breaks?

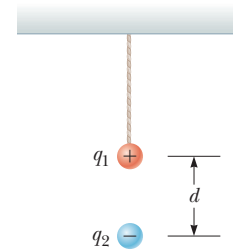

Figure P23.64

65. **AMT** A uniform electric field of magnitude 640 N/C exists between two parallel plates that are 4.00 cm apart. A proton is released from rest at the positive plate at the same instant an electron is released from rest at the negative plate. (a) Determine the distance from the positive plate at which the two pass each other. Ignore the electrical attraction between the proton and electron. (b) **What If?** Repeat part (a) for a sodium ion (Na^+) and a chloride ion (Cl^-).
66. Two small silver spheres, each with a mass of 10.0 g, are separated by 1.00 m. Calculate the fraction of the electrons in one sphere that must be transferred to the other to produce an attractive force of 1.00×10^4 N (about 1 ton) between the spheres. The number of electrons per atom of silver is 47.

- 67.** A charged cork ball of mass 1.00 g is suspended on a light string in the presence of a uniform electric field as shown in Figure P23.67. When $\vec{E} = (3.00\hat{i} + 5.00\hat{j}) \times 10^5\text{ N/C}$, the ball is in equilibrium at $\theta = 37.0^\circ$. Find (a) the charge on the ball and (b) the tension in the string.

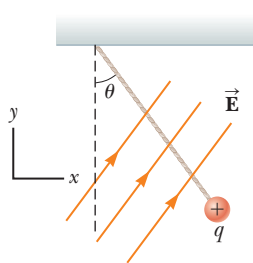

Figure P23.67

Problems 67 and 68.

- 68.** A charged cork ball of mass m is suspended on a light string in the presence of a uniform electric field as shown in Figure P23.67. When $\vec{E} = A\hat{i} + B\hat{j}$, where A and B are positive quantities, the ball is in equilibrium at the angle θ . Find (a) the charge on the ball and (b) the tension in the string.
- 69.** Three charged particles are aligned along the x axis as shown in Figure P23.69. Find the electric field at (a) the position $(2.00\text{ m}, 0)$ and (b) the position $(0, 2.00\text{ m})$.

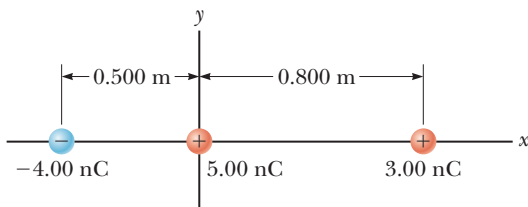

Figure P23.69

- 70.** Two point charges $q_A = -12.0\ \mu\text{C}$ and $q_B = 45.0\ \mu\text{C}$ and a third particle with unknown charge q_C are located on the x axis. The particle q_A is at the origin, and q_B is at $x = 15.0\text{ cm}$. The third particle is to be placed so that each particle is in equilibrium under the action of the electric forces exerted by the other two particles. (a) Is this situation possible? If so, is it possible in more than one way? Explain. Find (b) the required location and (c) the magnitude and the sign of the charge of the third particle.

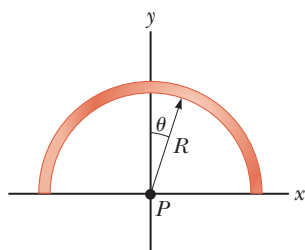

Figure P23.71

- 72.** Four identical charged particles ($q = +10.0\ \mu\text{C}$) are located on the corners of a rectangle as shown in Figure P23.72. The dimensions of the rectangle are $L = 60.0\text{ cm}$ and $W = 15.0\text{ cm}$. Calculate (a) the magnitude and (b) the direction of the total electric force exerted on the charge at the lower left corner by the other three charges.

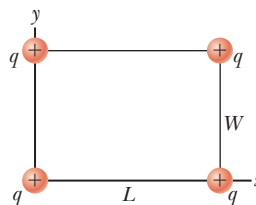

Figure P23.72

- 73.** Two small spheres hang in equilibrium at the bottom ends of threads, 40.0 cm long, that have their top ends tied to the same fixed point. One sphere has mass 2.40 g and charge $+300\text{ nC}$. The other sphere has the same mass and charge $+200\text{ nC}$. Find the distance between the centers of the spheres.

- 74.** Why is the following situation impossible? An electron enters a region of uniform electric field between two parallel plates. The plates are used in a cathode-ray tube to adjust the position of an electron beam on a distant fluorescent screen. The magnitude of the electric field between the plates is 200 N/C . The plates are 0.200 m in length and are separated by 1.50 cm . The electron enters the region at a speed of $3.00 \times 10^6\text{ m/s}$, traveling parallel to the plane of the plates in the direction of their length. It leaves the plates heading toward its correct location on the fluorescent screen.

- 75. Review.** Two identical blocks resting on a frictionless, horizontal surface are connected by a light spring having a spring constant $k = 100\text{ N/m}$ and an unstretched length $L_i = 0.400\text{ m}$ as shown in Figure P23.75a. A charge Q is slowly placed on each block, causing the spring to stretch to an equilibrium length $L = 0.500\text{ m}$ as shown in Figure P23.75b. Determine the value of Q , modeling the blocks as charged particles.

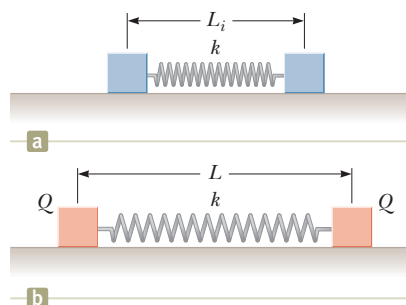

Figure P23.75 Problems 75 and 76.

- 76. Review.** Two identical blocks resting on a frictionless, horizontal surface are connected by a light spring having a spring constant k and an unstretched length L_i as shown in Figure P23.75a. A charge Q is slowly placed on each block, causing the spring to stretch to an equilibrium length L as shown in Figure P23.75b. Determine the value of Q , modeling the blocks as charged particles.

- 77.** Three identical point charges, each of mass $m = 0.100\text{ kg}$, hang from three strings as shown in Figure

P23.77. If the lengths of the left and right strings are each $L = 30.0$ cm and the angle θ is 45.0° , determine the value of q .

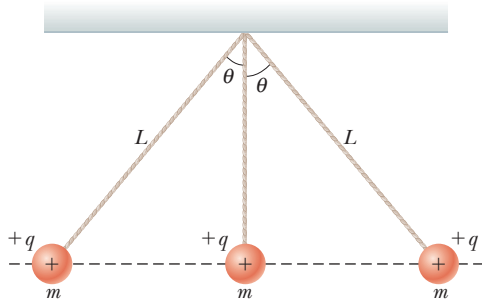

Figure P23.77

78. Show that the maximum magnitude E_{\max} of the electric field along the axis of a uniformly charged ring occurs at $x = a/\sqrt{2}$ (see Fig. 23.16) and has the value $Q/(6\sqrt{3}\pi\epsilon_0 a^2)$.
79. Two hard rubber spheres, each of mass $m = 15.0$ g, are rubbed with fur on a dry day and are then suspended with two insulating strings of length $L = 5.00$ cm whose support points are a distance $d = 3.00$ cm from each other as shown in Figure P23.79. During the rubbing process, one sphere receives exactly twice the charge of the other. They are observed to hang at equilibrium, each at an angle of $\theta = 10.0^\circ$ with the vertical. Find the amount of charge on each sphere.

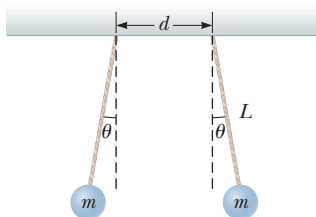

Figure P23.79

80. Two identical beads each have a mass m and charge q . When placed in a hemispherical bowl of radius R with frictionless, nonconducting walls, the beads move, and at equilibrium, they are a distance d apart (Fig. P23.80). (a) Determine the charge q on each bead. (b) Determine the charge required for d to become equal to $2R$.

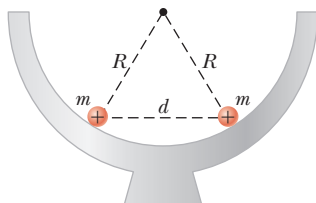

Figure P23.80

81. Two small spheres of mass m are suspended from strings of length ℓ that are connected at a common point. One sphere has charge Q and the other charge $2Q$. The strings make angles θ_1 and θ_2 with the vertical.

(a) Explain how θ_1 and θ_2 are related. (b) Assume θ_1 and θ_2 are small. Show that the distance r between the spheres is approximately

$$r \approx \left(\frac{4k_e Q^2 \ell}{mg} \right)^{1/3}$$

82. **Review.** A negatively charged particle $-q$ is placed at the center of a uniformly charged ring, where the ring has a total positive charge Q as shown in Figure P23.82. The particle, confined to move along the x axis, is moved a small distance x along the axis (where $x \ll a$) and released. Show that the particle oscillates in simple harmonic motion with a frequency given by

$$f = \frac{1}{2\pi} \left(\frac{k_e q Q}{m a^3} \right)^{1/2}$$

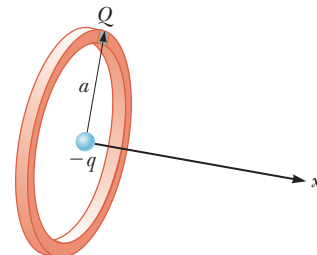

Figure P23.82

83. **Review.** A 1.00-g cork ball with charge $2.00 \mu\text{C}$ is suspended vertically on a 0.500-m-long light string in the presence of a uniform, downward-directed electric field of magnitude $E = 1.00 \times 10^5$ N/C. If the ball is displaced slightly from the vertical, it oscillates like a simple pendulum. (a) Determine the period of this oscillation. (b) Should the effect of gravitation be included in the calculation for part (a)? Explain.

Challenge Problems

84. Identical thin rods of length $2a$ carry equal charges $+Q$ uniformly distributed along their lengths. The rods lie along the x axis with their centers separated by a distance $b > 2a$ (Fig. P23.84). Show that the magnitude of the force exerted by the left rod on the right one is

$$F = \left(\frac{k_e Q^2}{4a^2} \right) \ln \left(\frac{b^2}{b^2 - 4a^2} \right)$$

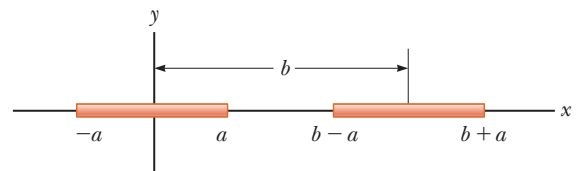

Figure P23.84

85. Eight charged particles, each of magnitude q , are located on the corners of a cube of edge s as shown in Figure P23.85 (page 724). (a) Determine the x , y , and z components of the total force exerted by the other charges on the charge located at point A. What are

(b) the magnitude and (c) the direction of this total force?

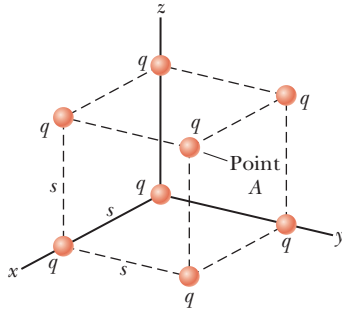

Figure P23.85 Problems 85 and 86.

86. Consider the charge distribution shown in Figure P23.85. (a) Show that the magnitude of the electric field at the center of any face of the cube has a value of $2.18k_e q/s^2$. (b) What is the direction of the electric field at the center of the top face of the cube?
87. **Review.** An electric dipole in a uniform horizontal electric field is displaced slightly from its equilibrium position as shown in Figure P23.87, where θ is small. The separation of the charges is $2a$, and each of the two particles has mass m . (a) Assuming the dipole is released from this position, show that its angular orientation exhibits simple harmonic motion with a frequency

$$f = \frac{1}{2\pi} \sqrt{\frac{qE}{ma}}$$

What If? (b) Suppose the masses of the two charged particles in the dipole are not the same even though each particle continues to have charge q . Let the masses of the particles be m_1 and m_2 . Show that the frequency of the oscillation in this case is

$$f = \frac{1}{2\pi} \sqrt{\frac{qE(m_1 + m_2)}{2am_1m_2}}$$

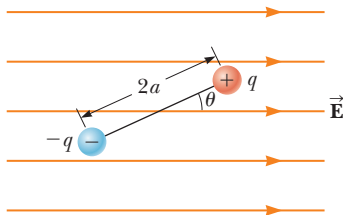

Figure P23.87

88. Inez is putting up decorations for her sister's quinceañera (fifteenth birthday party). She ties three light silk ribbons together to the top of a gateway and hangs a rubber balloon from each ribbon (Fig. P23.88). To include the effects of the gravitational and buoyant forces on it, each balloon can be modeled as a particle of mass 2.00 g, with its center 50.0 cm from the point of support. Inez rubs the whole surface of each balloon with her woolen scarf, making the balloons hang separately with gaps between them. Looking directly upward from below the balloons, Inez notices that the centers of the hanging balloons form a horizontal equilateral triangle with sides 30.0 cm long. What is the common charge each balloon carries?

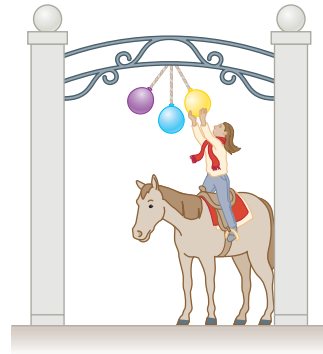

Figure P23.88

89. A line of charge with uniform density 35.0 nC/m lies along the line $y = -15.0$ cm between the points with coordinates $x = 0$ and $x = 40.0$ cm. Find the electric field it creates at the origin.
90. A particle of mass m and charge q moves at high speed along the x axis. It is initially near $x = -\infty$, and it ends up near $x = +\infty$. A second charge Q is fixed at the point $x = 0$, $y = -d$. As the moving charge passes the stationary charge, its x component of velocity does not change appreciably, but it acquires a small velocity in the y direction. Determine the angle through which the moving charge is deflected from the direction of its initial velocity.
91. Two particles, each with charge 52.0 nC, are located on the y axis at $y = 25.0$ cm and $y = -25.0$ cm. (a) Find the vector electric field at a point on the x axis as a function of x . (b) Find the field at $x = 36.0$ cm. (c) At what location is the field $1.00\hat{i}$ kN/C? You may need a computer to solve this equation. (d) At what location is the field $16.0\hat{i}$ kN/C?

Gauss's Law



- 24.1 Electric Flux
- 24.2 Gauss's Law
- 24.3 Application of Gauss's Law to Various Charge Distributions
- 24.4 Conductors in Electrostatic Equilibrium

In Chapter 23, we showed how to calculate the electric field due to a given charge distribution by integrating over the distribution. In this chapter, we describe *Gauss's law* and an alternative procedure for calculating electric fields. Gauss's law is based on the inverse-square behavior of the electric force between point charges. Although Gauss's law is a direct consequence of Coulomb's law, it is more convenient for calculating the electric fields of highly symmetric charge distributions and makes it possible to deal with complicated problems using qualitative reasoning. As we show in this chapter, Gauss's law is important in understanding and verifying the properties of conductors in electrostatic equilibrium.

In a tabletop plasma ball, the colorful lines emanating from the sphere give evidence of strong electric fields. Using Gauss's law, we show in this chapter that the electric field surrounding a uniformly charged sphere is identical to that of a point charge. (Steve Cole/Getty Images)

4.1 Electric Flux

The concept of electric field lines was described qualitatively in Chapter 23. We now treat electric field lines in a more quantitative way.

Consider an electric field that is uniform in both magnitude and direction as shown in Figure 24.1. The field lines penetrate a rectangular surface of area whose plane is oriented perpendicular to the field. Recall from Section 23.6 that the number of lines per unit area (in other words, the *line density*) is proportional to the magnitude of the electric field. Therefore, the total number of lines penetrating the surface is proportional to the product EA . This product of the magnitude of the electric field and surface area perpendicular to the field is called the **electric flux** (uppercase Greek letter phi):

(24.1)

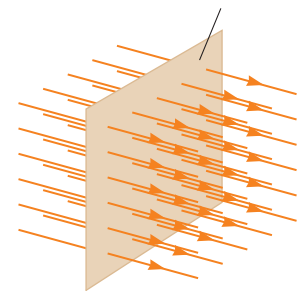

Figure 24.1 Field lines representing a uniform electric field penetrating a plane of area perpendicular to the field.

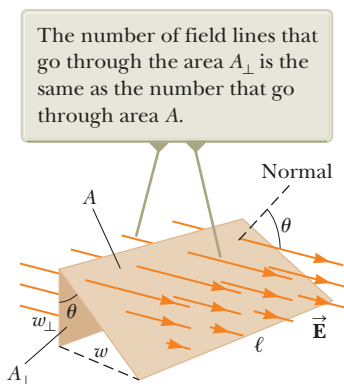

Figure 24.2 Field lines representing a uniform electric field penetrating an area A whose normal is at an angle θ to the field.

From the SI units of E and A , we see that Φ_E has units of newton meters squared per coulomb ($\text{N} \cdot \text{m}^2/\text{C}$). Electric flux is proportional to the number of electric field lines penetrating some surface.

If the surface under consideration is not perpendicular to the field, the flux through it must be less than that given by Equation 24.1. Consider Figure 24.2, where the normal to the surface of area A is at an angle θ to the uniform electric field. Notice that the number of lines that cross this area A is equal to the number of lines that cross the area A_{\perp} , which is a projection of area A onto a plane oriented perpendicular to the field. The area A is the product of the length and the width of the surface: $A = \ell w$. At the left edge of the figure, we see that the widths of the surfaces are related by $w_{\perp} = w \cos \theta$. The area A_{\perp} is given by $A_{\perp} = \ell w_{\perp} = \ell w \cos \theta$ and we see that the two areas are related by $A_{\perp} = A \cos \theta$. Because the flux through A equals the flux through A_{\perp} , the flux through A is

$$\Phi_E = EA_{\perp} = EA \cos \theta \quad (24.2)$$

From this result, we see that the flux through a surface of fixed area A has a maximum value EA when the surface is perpendicular to the field (when the normal to the surface is parallel to the field, that is, when $\theta = 0^\circ$ in Fig. 24.2); the flux is zero when the surface is parallel to the field (when the normal to the surface is perpendicular to the field, that is, when $\theta = 90^\circ$).

In this discussion, the angle θ is used to describe the orientation of the surface of area A . We can also interpret the angle as that between the electric field vector and the normal to the surface. In this case, the product $E \cos \theta$ in Equation 24.2 is the component of the electric field perpendicular to the surface. The flux through the surface can then be written $\Phi_E = (E \cos \theta)A = E_n A$, where we use E_n as the component of the electric field normal to the surface.

We assumed a uniform electric field in the preceding discussion. In more general situations, the electric field may vary over a large surface. Therefore, the definition of flux given by Equation 24.2 has meaning only for a small element of area over which the field is approximately constant. Consider a general surface divided into a large number of small elements, each of area ΔA_i . It is convenient to define a vector $\Delta \vec{A}_i$ whose magnitude represents the area of the i th element of the large surface and whose direction is defined to be *perpendicular* to the surface element as shown in Figure 24.3. The electric field \vec{E}_i at the location of this element makes an angle θ_i with the vector $\Delta \vec{A}_i$. The electric flux $\Phi_{E,i}$ through this element is

$$\Phi_{E,i} = E_i \Delta A_i \cos \theta_i = \vec{E}_i \cdot \Delta \vec{A}_i$$

where we have used the definition of the scalar product of two vectors ($\vec{A} \cdot \vec{B} \equiv AB \cos \theta$; see Chapter 7). Summing the contributions of all elements gives an approximation to the total flux through the surface:

$$\Phi_E \approx \sum \vec{E}_i \cdot \Delta \vec{A}_i$$

If the area of each element approaches zero, the number of elements approaches infinity and the sum is replaced by an integral. Therefore, the general definition of electric flux is

$$\Phi_E \equiv \int_{\text{surface}} \vec{E} \cdot d\vec{A} \quad (24.3)$$

Equation 24.3 is a *surface integral*, which means it must be evaluated over the surface in question. In general, the value of Φ_E depends both on the field pattern and on the surface.

We are often interested in evaluating the flux through a *closed surface*, defined as a surface that divides space into an inside and an outside region so that one cannot move from one region to the other without crossing the surface. The surface of a sphere, for example, is a closed surface. By convention, if the area element in Equa-

The electric field makes an angle θ_i with the vector $\Delta \vec{A}_i$, defined as being normal to the surface element.

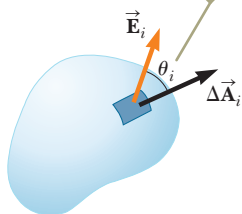

Figure 24.3 A small element of surface area ΔA_i in an electric field.

Definition of electric flux ►

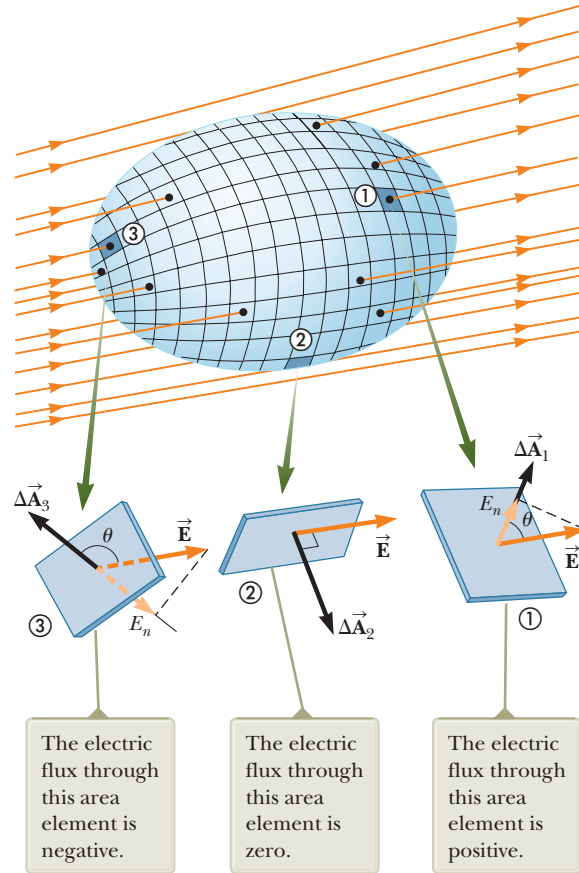

Figure 24.4 A closed surface in an electric field. The area vectors are, by convention, normal to the surface and point outward.

tion 24.3 is part of a closed surface, the direction of the area vector is chosen so that the vector points outward from the surface. If the area element is not part of a closed surface, the direction of the area vector is chosen so that the angle between the area vector and the electric field vector is less than or equal to 90° .

Consider the closed surface in Figure 24.4. The vectors $\Delta\vec{A}_i$ point in different directions for the various surface elements, but for each element they are normal to the surface and point outward. At the element labeled ①, the field lines are crossing the surface from the inside to the outside and $\theta < 90^\circ$; hence, the flux $\Phi_{E,1} = \vec{E} \cdot \Delta\vec{A}_1$ through this element is positive. For element ②, the field lines graze the surface (perpendicular to $\Delta\vec{A}_2$); therefore, $\theta = 90^\circ$ and the flux is zero. For elements such as ③, where the field lines are crossing the surface from outside to inside, $180^\circ > \theta > 90^\circ$ and the flux is negative because $\cos \theta$ is negative. The *net* flux through the surface is proportional to the net number of lines leaving the surface, where the net number means *the number of lines leaving the surface minus the number of lines entering the surface*. If more lines are leaving than entering, the net flux is positive. If more lines are entering than leaving, the net flux is negative. Using the symbol \oint to represent an integral over a closed surface, we can write the net flux Φ_E through a closed surface as

$$\Phi_E = \oint \vec{E} \cdot d\vec{A} = \oint E_n dA \quad (24.4)$$

where E_n represents the component of the electric field normal to the surface.

Quick Quiz 24.1 Suppose a point charge is located at the center of a spherical surface. The electric field at the surface of the sphere and the total flux through the sphere are determined. Now the radius of the sphere is halved.

- ∴ What happens to the flux through the sphere and the magnitude of the electric field at the surface of the sphere? (a) The flux and field both increase.
- ∴ (b) The flux and field both decrease. (c) The flux increases, and the field decreases. (d) The flux decreases, and the field increases. (e) The flux remains the same, and the field increases. (f) The flux decreases, and the field remains the same.

Example 24.1 Flux Through a Cube

Consider a uniform electric field \vec{E} oriented in the x direction in empty space. A cube of edge length ℓ is placed in the field, oriented as shown in Figure 24.5. Find the net electric flux through the surface of the cube.

SOLUTION

Conceptualize Examine Figure 24.5 carefully. Notice that the electric field lines pass through two faces perpendicularly and are parallel to four other faces of the cube.

Categorize We evaluate the flux from its definition, so we categorize this example as a substitution problem.

The flux through four of the faces (③, ④, and the unnumbered faces) is zero because \vec{E} is parallel to the four faces and therefore perpendicular to $d\vec{A}$ on these faces.

Write the integrals for the net flux through faces ① and ②:

For face ①, \vec{E} is constant and directed inward but $d\vec{A}_1$ is directed outward ($\theta = 180^\circ$). Find the flux through this face:

For face ②, \vec{E} is constant and outward and in the same direction as $d\vec{A}_2$ ($\theta = 0^\circ$). Find the flux through this face:

Find the net flux by adding the flux over all six faces:

$$\Phi_E = \int_1 \vec{E} \cdot d\vec{A} + \int_2 \vec{E} \cdot d\vec{A}$$

$$\int_1 \vec{E} \cdot d\vec{A} = \int_1 E(\cos 180^\circ) dA = -E \int_1 dA = -EA = -E\ell^2$$

$$\int_2 \vec{E} \cdot d\vec{A} = \int_2 E(\cos 0^\circ) dA = E \int_2 dA = +EA = E\ell^2$$

$$\Phi_E = -E\ell^2 + E\ell^2 + 0 + 0 + 0 + 0 = 0$$

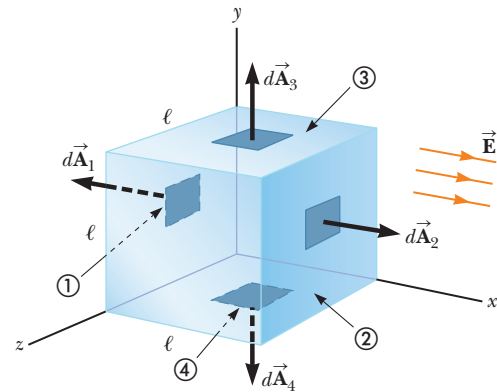

Figure 24.5 (Example 24.1) A closed surface in the shape of a cube in a uniform electric field oriented parallel to the x axis. Side ④ is the bottom of the cube, and side ① is opposite side ②.

When the charge is at the center of the sphere, the electric field is everywhere normal to the surface and constant in magnitude.

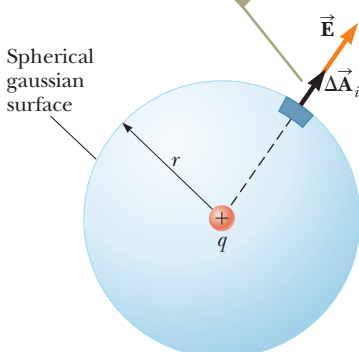

Figure 24.6 A spherical gaussian surface of radius r surrounding a positive point charge q .

24.2 Gauss's Law

In this section, we describe a general relationship between the net electric flux through a closed surface (often called a *gaussian surface*) and the charge enclosed by the surface. This relationship, known as *Gauss's law*, is of fundamental importance in the study of electric fields.

Consider a positive point charge q located at the center of a sphere of radius r as shown in Figure 24.6. From Equation 23.9, we know that the magnitude of the electric field everywhere on the surface of the sphere is $E = k_e q/r^2$. The field lines are directed radially outward and hence are perpendicular to the surface at every point on the surface. That is, at each surface point, \vec{E} is parallel to the vector $\Delta\vec{A}_i$ representing a local element of area ΔA_i surrounding the surface point. Therefore,

$$\vec{E} \cdot \Delta\vec{A}_i = E \Delta A_i$$

and, from Equation 24.4, we find that the net flux through the gaussian surface is

$$\Phi_E = \oint \vec{E} \cdot d\vec{A} = \oint E dA = E \oint dA$$

where we have moved E outside of the integral because, by symmetry, E is constant over the surface. The value of E is given by $E = k_e q/r^2$. Furthermore, because the surface is spherical, $\oint dA = A = 4\pi r^2$. Hence, the net flux through the gaussian surface is

$$\Phi_E = k_e \frac{q}{r^2} (4\pi r^2) = 4\pi k_e q$$

Recalling from Equation 23.3 that $k_e = 1/4\pi\epsilon_0$, we can write this equation in the form

$$\Phi_E = \frac{q}{\epsilon_0} \quad (24.5)$$

Equation 24.5 shows that the net flux through the spherical surface is proportional to the charge inside the surface. The flux is independent of the radius r because the area of the spherical surface is proportional to r^2 , whereas the electric field is proportional to $1/r^2$. Therefore, in the product of area and electric field, the dependence on r cancels.

Now consider several closed surfaces surrounding a charge q as shown in Figure 24.7. Surface S_1 is spherical, but surfaces S_2 and S_3 are not. From Equation 24.5, the flux that passes through S_1 has the value q/ϵ_0 . As discussed in the preceding section, flux is proportional to the number of electric field lines passing through a surface. The construction shown in Figure 24.7 shows that the number of lines through S_1 is equal to the number of lines through the nonspherical surfaces S_2 and S_3 . Therefore,

the net flux through *any* closed surface surrounding a point charge q is given by q/ϵ_0 and is independent of the shape of that surface.

Now consider a point charge located *outside* a closed surface of arbitrary shape as shown in Figure 24.8. As can be seen from this construction, any electric field line entering the surface leaves the surface at another point. The number of electric field lines entering the surface equals the number leaving the surface. Therefore, the net electric flux through a closed surface that surrounds no charge is zero. Applying this result to Example 24.1, we see that the net flux through the cube is zero because there is no charge inside the cube.

Let's extend these arguments to two generalized cases: (1) that of many point charges and (2) that of a continuous distribution of charge. We once again use the superposition principle, which states that the electric field due to many charges is



Karl Friedrich Gauss
German mathematician and astronomer (1777–1855)

Gauss received a doctoral degree in mathematics from the University of Helmstedt in 1799. In addition to his work in electromagnetism, he made contributions to mathematics and science in number theory, statistics, non-Euclidean geometry, and cometary orbital mechanics. He was a founder of the German Magnetic Union, which studies the Earth's magnetic field on a continual basis.

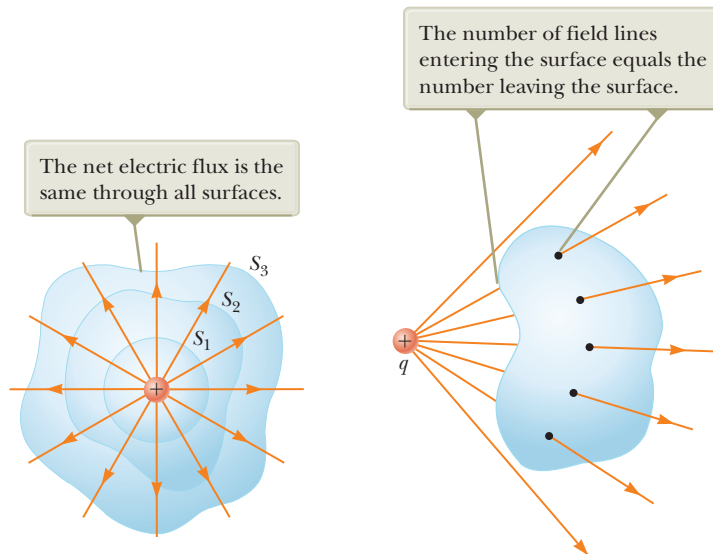

Figure 24.7 Closed surfaces of various shapes surrounding a positive charge.

Figure 24.8 A point charge located *outside* a closed surface.

Charge q_4 does not contribute to the flux through any surface because it is outside all surfaces.

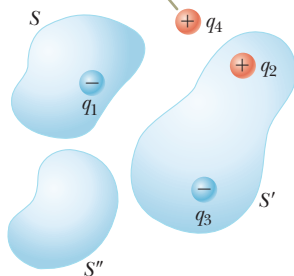

Figure 24.9 The net electric flux through any closed surface depends only on the charge *inside* that surface. The net flux through surface S is q_1/ϵ_0 , the net flux through surface S' is $(q_2 + q_3)/\epsilon_0$, and the net flux through surface S'' is zero.

Pitfall Prevention 24.1

Zero Flux Is Not Zero Field

In two situations, there is zero flux through a closed surface: either (1) there are no charged particles enclosed by the surface or (2) there are charged particles enclosed, but the net charge inside the surface is zero. For either situation, it is *incorrect* to conclude that the electric field on the surface is zero. Gauss's law states that the electric *flux* is proportional to the enclosed charge, not the electric *field*.

the vector sum of the electric fields produced by the individual charges. Therefore, the flux through any closed surface can be expressed as

$$\oint \vec{\mathbf{E}} \cdot d\vec{\mathbf{A}} = \oint (\vec{\mathbf{E}}_1 + \vec{\mathbf{E}}_2 + \cdots) \cdot d\vec{\mathbf{A}}$$

where $\vec{\mathbf{E}}$ is the total electric field at any point on the surface produced by the vector addition of the electric fields at that point due to the individual charges. Consider the system of charges shown in Figure 24.9. The surface S surrounds only one charge, q_1 ; hence, the net flux through S is q_1/ϵ_0 . The flux through S due to charges q_2 , q_3 , and q_4 outside it is zero because each electric field line from these charges that enters S at one point leaves it at another. The surface S' surrounds charges q_2 and q_3 ; hence, the net flux through it is $(q_2 + q_3)/\epsilon_0$. Finally, the net flux through surface S'' is zero because there is no charge inside this surface. That is, *all* the electric field lines that enter S'' at one point leave at another. Charge q_4 does not contribute to the net flux through any of the surfaces.

The mathematical form of **Gauss's law** is a generalization of what we have just described and states that the net flux through *any* closed surface is

$$\Phi_E = \oint \vec{\mathbf{E}} \cdot d\vec{\mathbf{A}} = \frac{q_{\text{in}}}{\epsilon_0} \quad (24.6)$$

where $\vec{\mathbf{E}}$ represents the electric field at any point on the surface and q_{in} represents the net charge inside the surface.

When using Equation 24.6, you should note that although the charge q_{in} is the net charge inside the gaussian surface, $\vec{\mathbf{E}}$ represents the *total electric field*, which includes contributions from charges both inside and outside the surface.

In principle, Gauss's law can be solved for $\vec{\mathbf{E}}$ to determine the electric field due to a system of charges or a continuous distribution of charge. In practice, however, this type of solution is applicable only in a limited number of highly symmetric situations. In the next section, we use Gauss's law to evaluate the electric field for charge distributions that have spherical, cylindrical, or planar symmetry. If one chooses the gaussian surface surrounding the charge distribution carefully, the integral in Equation 24.6 can be simplified and the electric field determined.

- Quick Quiz 24.2** If the net flux through a gaussian surface is zero, the following four statements *could be true*. Which of the statements *must be true*? (a) There are no charges inside the surface. (b) The net charge inside the surface is zero. (c) The electric field is zero everywhere on the surface. (d) The number of electric field lines entering the surface equals the number leaving the surface.

Conceptual Example 24.2 Flux Due to a Point Charge

A spherical gaussian surface surrounds a point charge q . Describe what happens to the total flux through the surface if (A) the charge is tripled, (B) the radius of the sphere is doubled, (C) the surface is changed to a cube, and (D) the charge is moved to another location inside the surface.

SOLUTION

- (A) The flux through the surface is tripled because flux is proportional to the amount of charge inside the surface.
 (B) The flux does not change because all electric field lines from the charge pass through the sphere, regardless of its radius.
 (C) The flux does not change when the shape of the gaussian surface changes because all electric field lines from the charge pass through the surface, regardless of its shape.
 (D) The flux does not change when the charge is moved to another location inside that surface because Gauss's law refers to the total charge enclosed, regardless of where the charge is located inside the surface.

24.3 Application of Gauss's Law to Various Charge Distributions

As mentioned earlier, Gauss's law is useful for determining electric fields when the charge distribution is highly symmetric. The following examples demonstrate ways of choosing the gaussian surface over which the surface integral given by Equation 24.6 can be simplified and the electric field determined. In choosing the surface, always take advantage of the symmetry of the charge distribution so that E can be removed from the integral. The goal in this type of calculation is to determine a surface for which each portion of the surface satisfies one or more of the following conditions:

1. The value of the electric field can be argued by symmetry to be constant over the portion of the surface.
2. The dot product in Equation 24.6 can be expressed as a simple algebraic product $E dA$ because \vec{E} and $d\vec{A}$ are parallel.
3. The dot product in Equation 24.6 is zero because \vec{E} and $d\vec{A}$ are perpendicular.
4. The electric field is zero over the portion of the surface.

Different portions of the gaussian surface can satisfy different conditions as long as every portion satisfies at least one condition. All four conditions are used in examples throughout the remainder of this chapter and will be identified by number. If the charge distribution does not have sufficient symmetry such that a gaussian surface that satisfies these conditions can be found, Gauss's law is still true, but is not useful for determining the electric field for that charge distribution.

Pitfall Prevention 24.2

Gaussian Surfaces Are Not Real

A gaussian surface is an imaginary surface you construct to satisfy the conditions listed here. It does not have to coincide with a physical surface in the situation.

Example 24.3 A Spherically Symmetric Charge Distribution

An insulating solid sphere of radius a has a uniform volume charge density ρ and carries a total positive charge Q (Fig. 24.10).

(A) Calculate the magnitude of the electric field at a point outside the sphere.

SOLUTION

Conceptualize Notice how this problem differs from our previous discussion of Gauss's law. The electric field due to point charges was discussed in Section 24.2. Now we are considering the electric field due to a distribution of charge. We found the field for various distributions of charge in Chapter 23 by integrating over the distribution. This example demonstrates a difference from our discussions in Chapter 23. In this chapter, we find the electric field using Gauss's law.

Categorize Because the charge is distributed uniformly throughout the sphere, the charge distribution has spherical symmetry and we can apply Gauss's law to find the electric field.

Analyze To reflect the spherical symmetry, let's choose a spherical gaussian surface of radius r , concentric with the sphere, as shown in Figure 24.10a. For this choice, condition (2) is satisfied everywhere on the surface and $\vec{E} \cdot d\vec{A} = E dA$.

continued

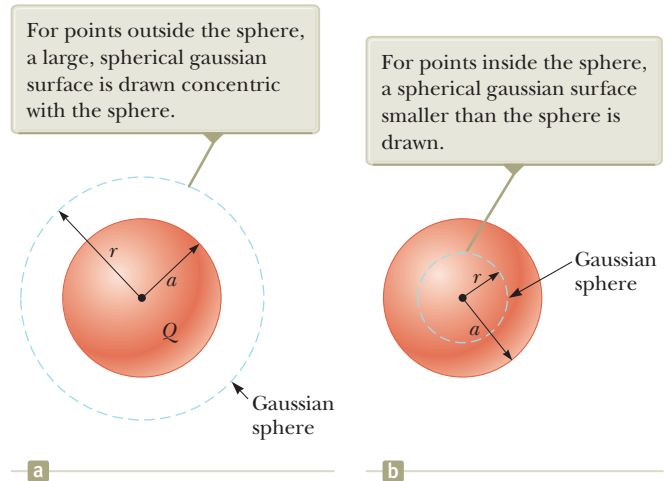

Figure 24.10 (Example 24.3) A uniformly charged insulating sphere of radius a and total charge Q . In diagrams such as this one, the dotted line represents the intersection of the gaussian surface with the plane of the page.

24.3 continued

Replace $\vec{\mathbf{E}} \cdot d\vec{\mathbf{A}}$ in Gauss's law with $E dA$:

$$\Phi_E = \oint \vec{\mathbf{E}} \cdot d\vec{\mathbf{A}} = \oint E dA = \frac{Q}{\epsilon_0}$$

By symmetry, E has the same value everywhere on the surface, which satisfies condition (1), so we can remove E from the integral:

$$\oint E dA = E \oint dA = E(4\pi r^2) = \frac{Q}{\epsilon_0}$$

Solve for E :

$$(1) \quad E = \frac{Q}{4\pi\epsilon_0 r^2} = k_e \frac{Q}{r^2} \quad (\text{for } r > a)$$

Finalize This field is identical to that for a point charge. Therefore, **the electric field due to a uniformly charged sphere in the region external to the sphere is equivalent to that of a point charge located at the center of the sphere.**

(B) Find the magnitude of the electric field at a point inside the sphere.

SOLUTION

Analyze In this case, let's choose a spherical gaussian surface having radius $r < a$, concentric with the insulating sphere (Fig. 24.10b). Let V' be the volume of this smaller sphere. To apply Gauss's law in this situation, recognize that the charge q_{in} within the gaussian surface of volume V' is less than Q .

Calculate q_{in} by using $q_{\text{in}} = \rho V'$:

$$q_{\text{in}} = \rho V' = \rho \left(\frac{4}{3}\pi r^3\right)$$

Notice that conditions (1) and (2) are satisfied everywhere on the gaussian surface in Figure 24.10b. Apply Gauss's law in the region $r < a$:

$$\oint E dA = E \oint dA = E(4\pi r^2) = \frac{q_{\text{in}}}{\epsilon_0}$$

Solve for E and substitute for q_{in} :

$$E = \frac{q_{\text{in}}}{4\pi\epsilon_0 r^2} = \frac{\rho \left(\frac{4}{3}\pi r^3\right)}{4\pi\epsilon_0 r^2} = \frac{\rho}{3\epsilon_0} r$$

Substitute $\rho = Q/\frac{4}{3}\pi a^3$ and $\epsilon_0 = 1/4\pi k_e$:

$$(2) \quad E = \frac{Q/\frac{4}{3}\pi a^3}{3(1/4\pi k_e)} r = k_e \frac{Q}{a^3} r \quad (\text{for } r < a)$$

Finalize This result for E differs from the one obtained in part (A). It shows that $E \rightarrow 0$ as $r \rightarrow 0$. Therefore, the result eliminates the problem that would exist at $r = 0$ if E varied as $1/r^2$ inside the sphere as it does outside the sphere. That is, if $E \propto 1/r^2$ for $r < a$, the field would be infinite at $r = 0$, which is physically impossible.

WHAT IF? Suppose the radial position $r = a$ is approached from inside the sphere and from outside. Do we obtain the same value of the electric field from both directions?

Answer Equation (1) shows that the electric field approaches a value from the outside given by

$$E = \lim_{r \rightarrow a} \left(k_e \frac{Q}{r^2} \right) = k_e \frac{Q}{a^2}$$

From the inside, Equation (2) gives

$$E = \lim_{r \rightarrow a} \left(k_e \frac{Q}{a^3} r \right) = k_e \frac{Q}{a^3} a = k_e \frac{Q}{a^2}$$

Therefore, the value of the field is the same as the surface is approached from both directions. A plot of E versus r is shown in Figure 24.11. Notice that the magnitude of the field is continuous.

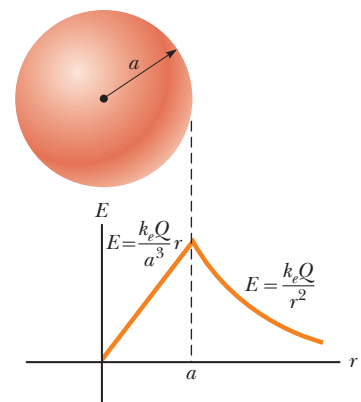

Figure 24.11 (Example 24.3) A plot of E versus r for a uniformly charged insulating sphere. The electric field inside the sphere ($r < a$) varies linearly with r . The field outside the sphere ($r > a$) is the same as that of a point charge Q located at $r = 0$.

Example 24.4 Cylindrically Symmetric Charge Distribution

Find the electric field a distance r from a line of positive charge of infinite length and constant charge per unit length λ (Fig. 24.12a).

SOLUTION

Conceptualize The line of charge is *infinitely* long. Therefore, the field is the same at all points equidistant from the line, regardless of the vertical position of the point in Figure 24.12a. We expect the field to become weaker as we move farther away from the line of charge.

Categorize Because the charge is distributed uniformly along the line, the charge distribution has cylindrical symmetry and we can apply Gauss's law to find the electric field.

Analyze The symmetry of the charge distribution requires that \vec{E} be perpendicular to the line charge and directed outward as shown in Figure 24.12b. To reflect the symmetry of the charge distribution, let's choose a cylindrical gaussian surface of radius r and length ℓ that is coaxial with the line charge. For the curved part of this surface, \vec{E} is constant in magnitude and perpendicular to the surface at each point, satisfying conditions (1) and (2). Furthermore, the flux through the ends of the gaussian cylinder is zero because \vec{E} is parallel to these surfaces. That is the first application we have seen of condition (3).

We must take the surface integral in Gauss's law over the entire gaussian surface. Because $\vec{E} \cdot d\vec{A}$ is zero for the flat ends of the cylinder, however, we restrict our attention to only the curved surface of the cylinder.

Apply Gauss's law and conditions (1) and (2) for the curved surface, noting that the total charge inside our gaussian surface is $\lambda\ell$:

Substitute the area $A = 2\pi r\ell$ of the curved surface:

Solve for the magnitude of the electric field:

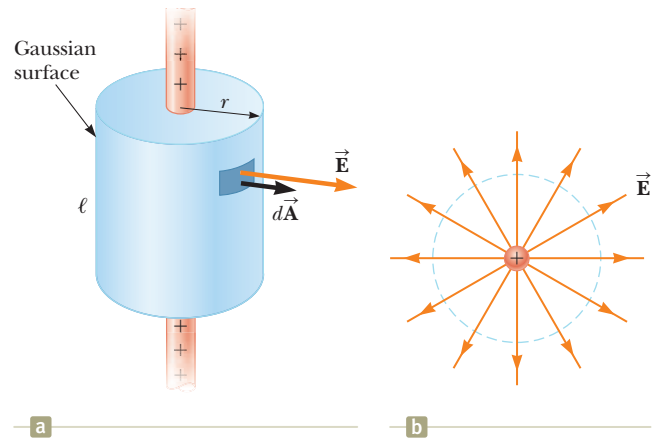

Figure 24.12 (Example 24.4) (a) An infinite line of charge surrounded by a cylindrical gaussian surface concentric with the line. (b) An end view shows that the electric field at the cylindrical surface is constant in magnitude and perpendicular to the surface.

$$\Phi_E = \oint \vec{E} \cdot d\vec{A} = E \oint dA = EA = \frac{q_{\text{in}}}{\epsilon_0} = \frac{\lambda\ell}{\epsilon_0}$$

$$E(2\pi r\ell) = \frac{\lambda\ell}{\epsilon_0}$$

$$E = \frac{\lambda}{2\pi\epsilon_0 r} = 2k_e \frac{\lambda}{r} \quad (24.7)$$

Finalize This result shows that the electric field due to a cylindrically symmetric charge distribution varies as $1/r$, whereas the field external to a spherically symmetric charge distribution varies as $1/r^2$. Equation 24.7 can also be derived by direct integration over the charge distribution. (See Problem 44 in Chapter 23.)

WHAT IF? What if the line segment in this example were not infinitely long?

Answer If the line charge in this example were of finite length, the electric field would not be given by Equation 24.7. A finite line charge does not possess sufficient symmetry to make use of Gauss's law because the magnitude of the electric field is no longer constant over the surface of the gaussian cylinder: the field near the ends of the line would be different from that far from the ends. Therefore, condition (1) would not be satisfied in this situation. Furthermore, \vec{E} is not perpendicular to the cylindrical surface at all points: the field vectors near the ends would have a component parallel to the line. Therefore, condition (2) would not be satisfied. For points close to a finite line charge and far from the ends, Equation 24.7 gives a good approximation of the value of the field.

It is left for you to show (see Problem 33) that the electric field inside a uniformly charged rod of finite radius and infinite length is proportional to r .

Example 24.5 A Plane of Charge

Find the electric field due to an infinite plane of positive charge with uniform surface charge density σ .

SOLUTION

Conceptualize Notice that the plane of charge is *infinitely* large. Therefore, the electric field should be the same at all points equidistant from the plane. How would you expect the electric field to depend on the distance from the plane?

Categorize Because the charge is distributed uniformly on the plane, the charge distribution is symmetric; hence, we can use Gauss's law to find the electric field.

Analyze By symmetry, \vec{E} must be perpendicular to the plane at all points. The direction of \vec{E} is away from positive charges, indicating that the direction of \vec{E} on one side of the plane must be opposite its direction on the other side as shown in Figure 24.13. A gaussian surface that reflects the symmetry is a small cylinder whose axis is perpendicular to the plane and whose ends each have an area A and are equidistant from the plane. Because \vec{E} is parallel to the curved surface of the cylinder—and therefore perpendicular to $d\vec{A}$ at all points on this surface—condition (3) is satisfied and there is no contribution to the surface integral from this surface. For the flat ends of the cylinder, conditions (1) and (2) are satisfied. The flux through each end of the cylinder is EA ; hence, the total flux through the entire gaussian surface is just that through the ends, $\Phi_E = 2EA$.

Write Gauss's law for this surface, noting that the enclosed charge is $q_{\text{in}} = \sigma A$:

$$\Phi_E = 2EA = \frac{q_{\text{in}}}{\epsilon_0} = \frac{\sigma A}{\epsilon_0}$$

Solve for E :

$$E = \frac{\sigma}{2\epsilon_0} \quad (24.8)$$

Finalize Because the distance from each flat end of the cylinder to the plane does not appear in Equation 24.8, we conclude that $E = \sigma/2\epsilon_0$ at *any* distance from the plane. That is, the field is uniform everywhere. Figure 24.14 shows this uniform field due to an infinite plane of charge, seen edge-on.

WHAT IF? Suppose two infinite planes of charge are parallel to each other, one positively charged and the other negatively charged. The surface charge densities of both planes are of the same magnitude. What does the electric field look like in this situation?

Answer We first addressed this configuration in the **What If?** section of Example 23.9. The electric fields due to the two planes add in the region between the planes, resulting in a uniform field of magnitude σ/ϵ_0 , and cancel elsewhere to give a field of zero. Figure 24.15 shows the field lines for such a configuration. This method is a practical way to achieve uniform electric fields with finite-sized planes placed close to each other.

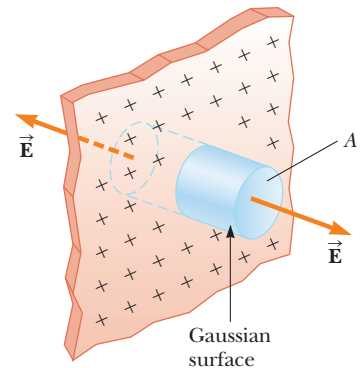

Figure 24.13 (Example 24.5) A cylindrical gaussian surface penetrating an infinite plane of charge. The flux is EA through each end of the gaussian surface and zero through its curved surface.

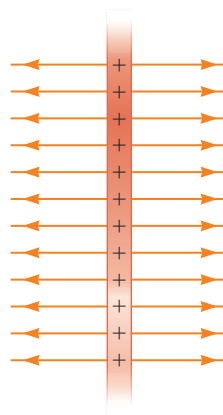

Figure 24.14 (Example 24.5) The electric field lines due to an infinite plane of positive charge.



Figure 24.15 (Example 24.5) The electric field lines between two infinite planes of charge, one positive and one negative. In practice, the field lines near the edges of finite-sized sheets of charge will curve outward.

Conceptual Example 24.6 Don't Use Gauss's Law Here!

Explain why Gauss's law cannot be used to calculate the electric field near an electric dipole, a charged disk, or a triangle with a point charge at each corner.

► 24.6 continued

SOLUTION

The charge distributions of all these configurations do not have sufficient symmetry to make the use of Gauss's law practical. We cannot find a closed surface surrounding any of these distributions for which all portions of the surface satisfy one or more of conditions (1) through (4) listed at the beginning of this section.

24.4 Conductors in Electrostatic Equilibrium

As we learned in Section 23.2, a good electrical conductor contains charges (electrons) that are not bound to any atom and therefore are free to move about within the material. When there is no net motion of charge within a conductor, the conductor is in **electrostatic equilibrium**. A conductor in electrostatic equilibrium has the following properties:

1. The electric field is zero everywhere inside the conductor, whether the conductor is solid or hollow.
2. If the conductor is isolated and carries a charge, the charge resides on its surface.
3. The electric field at a point just outside a charged conductor is perpendicular to the surface of the conductor and has a magnitude σ/ϵ_0 , where σ is the surface charge density at that point.
4. On an irregularly shaped conductor, the surface charge density is greatest at locations where the radius of curvature of the surface is smallest.

We verify the first three properties in the discussion that follows. The fourth property is presented here (but not verified until we have studied the appropriate material in Chapter 25) to provide a complete list of properties for conductors in electrostatic equilibrium.

We can understand the first property by considering a conducting slab placed in an external field \vec{E} (Fig. 24.16). The electric field inside the conductor *must* be zero, assuming electrostatic equilibrium exists. If the field were not zero, free electrons in the conductor would experience an electric force ($\vec{F} = q\vec{E}$) and would accelerate due to this force. This motion of electrons, however, would mean that the conductor is not in electrostatic equilibrium. Therefore, the existence of electrostatic equilibrium is consistent only with a zero field in the conductor.

Let's investigate how this zero field is accomplished. Before the external field is applied, free electrons are uniformly distributed throughout the conductor. When the external field is applied, the free electrons accelerate to the left in Figure 24.16, causing a plane of negative charge to accumulate on the left surface. The movement of electrons to the left results in a plane of positive charge on the right surface. These planes of charge create an additional electric field inside the conductor that opposes the external field. As the electrons move, the surface charge densities on the left and right surfaces increase until the magnitude of the internal field equals that of the external field, resulting in a net field of zero inside the conductor. The time it takes a good conductor to reach equilibrium is on the order of 10^{-16} s, which for most purposes can be considered instantaneous.

If the conductor is hollow, the electric field inside the conductor is also zero, whether we consider points in the conductor or in the cavity within the conductor. The zero value of the electric field in the cavity is easiest to argue with the concept of electric potential, so we will address this issue in Section 25.6.

Gauss's law can be used to verify the second property of a conductor in electrostatic equilibrium. Figure 24.17 shows an arbitrarily shaped conductor. A gaussian

Properties of a conductor in electrostatic equilibrium

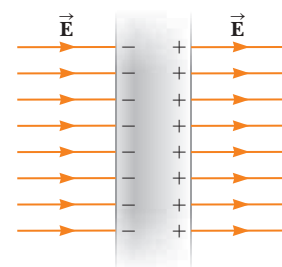

Figure 24.16 A conducting slab in an external electric field \vec{E} . The charges induced on the two surfaces of the slab produce an electric field that opposes the external field, giving a resultant field of zero inside the slab.

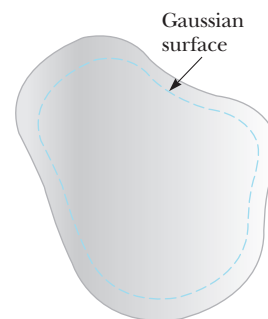

Figure 24.17 A conductor of arbitrary shape. The broken line represents a gaussian surface that can be just inside the conductor's surface.

surface is drawn inside the conductor and can be very close to the conductor's surface. As we have just shown, the electric field everywhere inside the conductor is zero when it is in electrostatic equilibrium. Therefore, the electric field must be zero at every point on the gaussian surface, in accordance with condition (4) in Section 24.3, and the net flux through this gaussian surface is zero. From this result and Gauss's law, we conclude that the net charge inside the gaussian surface is zero. Because there can be no net charge inside the gaussian surface (which is arbitrarily close to the conductor's surface), any net charge on the conductor must reside on its surface. Gauss's law does not indicate how this excess charge is distributed on the conductor's surface, only that it resides exclusively on the surface.

To verify the third property, let's begin with the perpendicularity of the field to the surface. If the field vector \vec{E} had a component parallel to the conductor's surface, free electrons would experience an electric force and move along the surface; in such a case, the conductor would not be in equilibrium. Therefore, the field vector must be perpendicular to the surface.

To determine the magnitude of the electric field, we use Gauss's law and draw a gaussian surface in the shape of a small cylinder whose end faces are parallel to the conductor's surface (Fig. 24.18). Part of the cylinder is just outside the conductor, and part is inside. The field is perpendicular to the conductor's surface from the condition of electrostatic equilibrium. Therefore, condition (3) in Section 24.3 is satisfied for the curved part of the cylindrical gaussian surface: there is no flux through this part of the gaussian surface because \vec{E} is parallel to the surface. There is no flux through the flat face of the cylinder inside the conductor because here $\vec{E} = 0$, which satisfies condition (4). Hence, the net flux through the gaussian surface is equal to that through only the flat face outside the conductor, where the field is perpendicular to the gaussian surface. Using conditions (1) and (2) for this face, the flux is EA , where E is the electric field just outside the conductor and A is the area of the cylinder's face. Applying Gauss's law to this surface gives

$$\Phi_E = \oint E \, dA = EA = \frac{q_{\text{in}}}{\epsilon_0} = \frac{\sigma A}{\epsilon_0}$$

where we have used $q_{\text{in}} = \sigma A$. Solving for E gives for the electric field immediately outside a charged conductor:

$$E = \frac{\sigma}{\epsilon_0} \quad (24.9)$$

- Quick Quiz 24.3** Your younger brother likes to rub his feet on the carpet and then touch you to give you a shock. While you are trying to escape the shock treatment, you discover a hollow metal cylinder in your basement, large enough to climb inside. In which of the following cases will you *not* be shocked? (a) You climb inside the cylinder, making contact with the inner surface, and your charged brother touches the outer metal surface. (b) Your charged brother is inside touching the inner metal surface and you are outside, touching the outer metal surface. (c) Both of you are outside the cylinder, touching its outer metal surface but not touching each other directly.

The flux through the gaussian surface is EA .

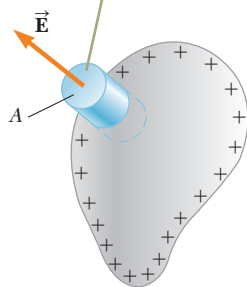

Figure 24.18 A gaussian surface in the shape of a small cylinder is used to calculate the electric field immediately outside a charged conductor.

Example 24.7

A Sphere Inside a Spherical Shell

A solid insulating sphere of radius a carries a net positive charge Q uniformly distributed throughout its volume. A conducting spherical shell of inner radius b and outer radius c is concentric with the solid sphere and carries a net charge $-2Q$. Using Gauss's law, find the electric field in the regions labeled ①, ②, ③, and ④ in Figure 24.19 and the charge distribution on the shell when the entire system is in electrostatic equilibrium.

24.7 continued

SOLUTION

Conceptualize Notice how this problem differs from Example 24.3. The charged sphere in Figure 24.10 appears in Figure 24.19, but it is now surrounded by a shell carrying a charge $-2Q$. Think about how the presence of the shell will affect the electric field of the sphere.

Categorize The charge is distributed uniformly throughout the sphere, and we know that the charge on the conducting shell distributes itself uniformly on the surfaces. Therefore, the system has spherical symmetry and we can apply Gauss's law to find the electric field in the various regions.

Analyze In region ②—between the surface of the solid sphere and the inner surface of the shell—we construct a spherical gaussian surface of radius r , where $a < r < b$, noting that the charge inside this surface is $+Q$ (the charge on the solid sphere). Because of the spherical symmetry, the electric field lines must be directed radially outward and be constant in magnitude on the gaussian surface.

The charge on the conducting shell creates zero electric field in the region $r < b$, so the shell has no effect on the field in region ② due to the sphere. Therefore, write an expression for the field in region ② as that due to the sphere from part (A) of Example 24.3:

$$E_2 = k_e \frac{Q}{r^2} \quad (\text{for } a < r < b)$$

Because the conducting shell creates zero field inside itself, it also has no effect on the field inside the sphere. Therefore, write an expression for the field in region ① as that due to the sphere from part (B) of Example 24.3:

$$E_1 = k_e \frac{Q}{a^3} r \quad (\text{for } r < a)$$

In region ④, where $r > c$, construct a spherical gaussian surface; this surface surrounds a total charge $q_{\text{in}} = Q + (-2Q) = -Q$. Therefore, model the charge distribution as a sphere with charge $-Q$ and write an expression for the field in region ④ from part (A) of Example 24.3:

$$E_4 = -k_e \frac{Q}{r^2} \quad (\text{for } r > c)$$

In region ③, the electric field must be zero because the spherical shell is a conductor in equilibrium:

$$E_3 = 0 \quad (\text{for } b < r < c)$$

Construct a gaussian surface of radius r in region ③, where $b < r < c$, and note that q_{in} must be zero because $E_3 = 0$. Find the amount of charge q_{inner} on the inner surface of the shell:

$$\begin{aligned} q_{\text{in}} &= q_{\text{sphere}} + q_{\text{inner}} \\ q_{\text{inner}} &= q_{\text{in}} - q_{\text{sphere}} = 0 - Q = -Q \end{aligned}$$

Finalize The charge on the inner surface of the spherical shell must be $-Q$ to cancel the charge $+Q$ on the solid sphere and give zero electric field in the material of the shell. Because the net charge on the shell is $-2Q$, its outer surface must carry a charge $-Q$.

WHAT IF? How would the results of this problem differ if the sphere were conducting instead of insulating?

Answer The only change would be in region ①, where $r < a$. Because there can be no charge inside a conductor in electrostatic equilibrium, $q_{\text{in}} = 0$ for a gaussian surface of radius $r < a$; therefore, on the basis of Gauss's law and symmetry, $E_1 = 0$. In regions ②, ③, and ④, there would be no way to determine from observations of the electric field whether the sphere is conducting or insulating.

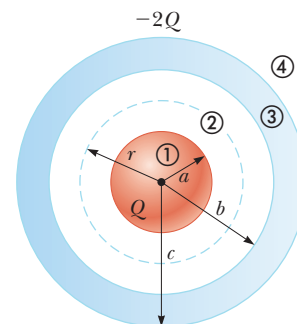

Figure 24.19 (Example 24.7) An insulating sphere of radius a and carrying a charge Q surrounded by a conducting spherical shell carrying a charge $-2Q$.

Summary

Definition

Electric flux is proportional to the number of electric field lines that penetrate a surface. If the electric field is uniform and makes an angle θ with the normal to a surface of area A , the electric flux through the surface is

$$\Phi_E = EA \cos \theta \quad (24.2)$$

In general, the electric flux through a surface is

$$\Phi_E \equiv \int_{\text{surface}} \vec{\mathbf{E}} \cdot d\vec{\mathbf{A}} \quad (24.3)$$

Concepts and Principles

Gauss's law says that the net electric flux Φ_E through any closed gaussian surface is equal to the *net* charge q_{in} inside the surface divided by ϵ_0 :

$$\Phi_E = \oint \vec{\mathbf{E}} \cdot d\vec{\mathbf{A}} = \frac{q_{\text{in}}}{\epsilon_0} \quad (24.6)$$

Using Gauss's law, you can calculate the electric field due to various symmetric charge distributions.

A conductor in **electrostatic equilibrium** has the following properties:

1. The electric field is zero everywhere inside the conductor, whether the conductor is solid or hollow.
2. If the conductor is isolated and carries a charge, the charge resides on its surface.
3. The electric field at a point just outside a charged conductor is perpendicular to the surface of the conductor and has a magnitude σ/ϵ_0 , where σ is the surface charge density at that point.
4. On an irregularly shaped conductor, the surface charge density is greatest at locations where the radius of curvature of the surface is smallest.

Objective Questions

1. denotes answer available in *Student Solutions Manual/Study Guide*

1. A cubical gaussian surface surrounds a long, straight, charged filament that passes perpendicularly through two opposite faces. No other charges are nearby. (i) Over how many of the cube's faces is the electric field zero? (a) 0 (b) 2 (c) 4 (d) 6 (ii) Through how many of the cube's faces is the electric flux zero? Choose from the same possibilities as in part (i).
2. A coaxial cable consists of a long, straight filament surrounded by a long, coaxial, cylindrical conducting shell. Assume charge Q is on the filament, zero net charge is on the shell, and the electric field is $E_1 \hat{\mathbf{i}}$ at a particular point P midway between the filament and the inner surface of the shell. Next, you place the cable into a uniform external field $-E_1 \hat{\mathbf{i}}$. What is the x component of the electric field at P then? (a) 0 (b) between 0 and E_1 (c) E_1 (d) between 0 and $-E_1$ (e) $-E_1$
3. In which of the following contexts can Gauss's law *not* be readily applied to find the electric field? (a) near a long, uniformly charged wire (b) above a large, uniformly charged plane (c) inside a uniformly charged ball (d) outside a uniformly charged sphere (e) Gauss's law can be readily applied to find the electric field in all these contexts.
4. A particle with charge q is located inside a cubical gaussian surface. No other charges are nearby. (i) If the particle is at the center of the cube, what is the flux through each one of the faces of the cube? (a) 0 (b) $q/2\epsilon_0$ (c) $q/6\epsilon_0$ (d) $q/8\epsilon_0$ (e) depends on the size of the cube (ii) If the particle can be moved to any point within the cube, what maximum value can the flux through one face approach? Choose from the same possibilities as in part (i).
5. Charges of 3.00 nC, -2.00 nC, -7.00 nC, and 1.00 nC are contained inside a rectangular box with length 1.00 m, width 2.00 m, and height 2.50 m. Outside the box are charges of 1.00 nC and 4.00 nC. What is the electric flux through the surface of the box? (a) 0 (b) $-5.64 \times 10^2 \text{ N} \cdot \text{m}^2/\text{C}$ (c) $-1.47 \times 10^3 \text{ N} \cdot \text{m}^2/\text{C}$ (d) $1.47 \times 10^3 \text{ N} \cdot \text{m}^2/\text{C}$ (e) $5.64 \times 10^2 \text{ N} \cdot \text{m}^2/\text{C}$
6. A large, metallic, spherical shell has no net charge. It is supported on an insulating stand and has a small hole at the top. A small tack with charge Q is lowered on a silk thread through the hole into the interior of the shell. (i) What is the charge on the inner surface of the shell, (a) Q (b) $Q/2$ (c) 0 (d) $-Q/2$ or (e) $-Q$? Choose your answers to the following questions from

the same possibilities. **(ii)** What is the charge on the outer surface of the shell? **(iii)** The tack is now allowed to touch the interior surface of the shell. After this contact, what is the charge on the tack? **(iv)** What is the charge on the inner surface of the shell now? **(v)** What is the charge on the outer surface of the shell now?

- Two solid spheres, both of radius 5 cm, carry identical total charges of $2 \mu\text{C}$. Sphere A is a good conductor. Sphere B is an insulator, and its charge is distributed uniformly throughout its volume. **(i)** How do the magnitudes of the electric fields they separately create at a radial distance of 6 cm compare? (a) $E_A > E_B = 0$ (b) $E_A > E_B > 0$ (c) $E_A = E_B > 0$ (d) $0 < E_A < E_B$ (e) $0 = E_A < E_B$ **(ii)** How do the magnitudes of the electric fields they separately create at radius 4 cm compare? Choose from the same possibilities as in part (i).
- A uniform electric field of 1.00 N/C is set up by a uniform distribution of charge in the xy plane. What is the electric field inside a metal ball placed 0.500 m above the xy plane? (a) 1.00 N/C (b) -1.00 N/C (c) 0 (d) 0.250 N/C (e) varies depending on the position inside the ball
- A solid insulating sphere of radius 5 cm carries electric charge uniformly distributed throughout its volume. Concentric with the sphere is a conducting spherical shell with no net charge as shown in Figure OQ24.9. The inner radius of the shell is 10 cm, and the outer radius is 15 cm. No other charges are nearby. (a) Rank

the magnitude of the electric field at points A (at radius 4 cm), B (radius 8 cm), C (radius 12 cm), and D (radius 16 cm) from largest to smallest. Display any cases of equality in your ranking. (b) Similarly rank the electric flux through concentric spherical surfaces through points A, B, C, and D.

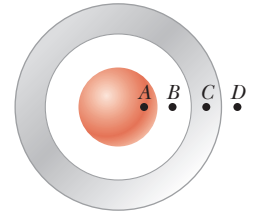

Figure OQ24.9

- A cubical gaussian surface is bisected by a large sheet of charge, parallel to its top and bottom faces. No other charges are nearby. **(i)** Over how many of the cube's faces is the electric field zero? (a) 0 (b) 2 (c) 4 (d) 6 **(ii)** Through how many of the cube's faces is the electric flux zero? Choose from the same possibilities as in part (i).
- Rank the electric fluxes through each gaussian surface shown in Figure OQ24.11 from largest to smallest. Display any cases of equality in your ranking.

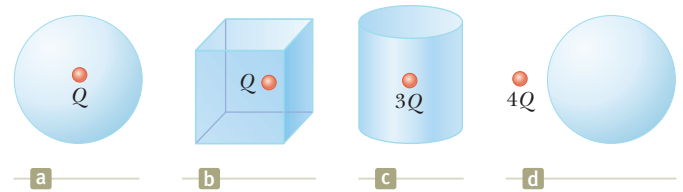

Figure OQ24.11

Conceptual Questions

1. denotes answer available in *Student Solutions Manual/Study Guide*

- Consider an electric field that is uniform in direction throughout a certain volume. Can it be uniform in magnitude? Must it be uniform in magnitude? Answer these questions (a) assuming the volume is filled with an insulating material carrying charge described by a volume charge density and (b) assuming the volume is empty space. State reasoning to prove your answers.
- A cubical surface surrounds a point charge q . Describe what happens to the total flux through the surface if (a) the charge is doubled, (b) the volume of the cube is doubled, (c) the surface is changed to a sphere, (d) the charge is moved to another location inside the surface, and (e) the charge is moved outside the surface.
- A uniform electric field exists in a region of space containing no charges. What can you conclude about the net electric flux through a gaussian surface placed in this region of space?
- If the total charge inside a closed surface is known but the distribution of the charge is unspecified, can you use Gauss's law to find the electric field? Explain.
- Explain why the electric flux through a closed surface with a given enclosed charge is independent of the size or shape of the surface.
- If more electric field lines leave a gaussian surface than enter it, what can you conclude about the net charge enclosed by that surface?
- A person is placed in a large, hollow, metallic sphere that is insulated from ground. (a) If a large charge is placed on the sphere, will the person be harmed upon touching the inside of the sphere? (b) Explain what will happen if the person also has an initial charge whose sign is opposite that of the charge on the sphere.
- Consider two identical conducting spheres whose surfaces are separated by a small distance. One sphere is given a large net positive charge, and the other is given a small net positive charge. It is found that the force between the spheres is attractive even though they both have net charges of the same sign. Explain how this attraction is possible.
- A common demonstration involves charging a rubber balloon, which is an insulator, by rubbing it on your hair and then touching the balloon to a ceiling or wall, which is also an insulator. Because of the electrical attraction between the charged balloon and the neutral wall, the balloon sticks to the wall. Imagine now that we have two infinitely large, flat sheets of insulating

material. One is charged, and the other is neutral. If these sheets are brought into contact, does an attractive force exist between them as there was for the balloon and the wall?

10. On the basis of the repulsive nature of the force between like charges and the freedom of motion of

charge within a conductor, explain why excess charge on an isolated conductor must reside on its surface.

11. The Sun is lower in the sky during the winter than it is during the summer. (a) How does this change affect the flux of sunlight hitting a given area on the surface of the Earth? (b) How does this change affect the weather?

Problems

WebAssign The problems found in this chapter may be assigned online in Enhanced WebAssign

1. straightforward; 2. intermediate; 3. challenging

1. full solution available in the *Student Solutions Manual/Study Guide*

AMT Analysis Model tutorial available in Enhanced WebAssign

GP Guided Problem

M Master It tutorial available in Enhanced WebAssign

W Watch It video solution available in Enhanced WebAssign

Section 24.1 Electric Flux

1. A flat surface of area 3.20 m^2 is rotated in a uniform electric field of magnitude $E = 6.20 \times 10^5 \text{ N/C}$. Determine the electric flux through this area (a) when the electric field is perpendicular to the surface and (b) when the electric field is parallel to the surface.

2. A vertical electric field of magnitude $2.00 \times 10^4 \text{ N/C}$ exists above the Earth's surface on a day when a thunderstorm is brewing. A car with a rectangular size of 6.00 m by 3.00 m is traveling along a dry gravel roadway sloping downward at 10.0° . Determine the electric flux through the bottom of the car.

3. A 40.0-cm -diameter circular loop is rotated in a uniform electric field until the position of maximum electric flux is found. The flux in this position is measured to be $5.20 \times 10^5 \text{ N} \cdot \text{m}^2/\text{C}$. What is the magnitude of the electric field?

4. Consider a closed triangular box resting within a horizontal electric field of magnitude $E = 7.80 \times 10^4 \text{ N/C}$ as shown in Figure P24.4. Calculate the electric flux through (a) the vertical rectangular surface, (b) the slanted surface, and (c) the entire surface of the box.

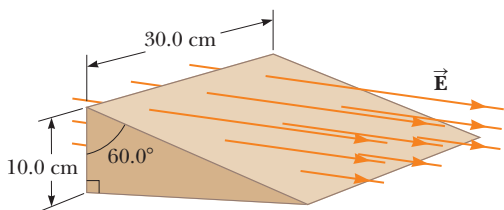

Figure P24.4

5. An electric field of magnitude 3.50 kN/C is applied along the x axis. Calculate the electric flux through a rectangular plane 0.350 m wide and 0.700 m long (a) if the plane is parallel to the yz plane, (b) if the plane is parallel to the xy plane, and (c) if the plane contains the y axis and its normal makes an angle of 40.0° with the x axis.

6. A nonuniform electric field is given by the expression

$$\vec{E} = ay\hat{i} + bz\hat{j} + cx\hat{k}$$

where a , b , and c are constants. Determine the electric flux through a rectangular surface in the xy plane, extending from $x = 0$ to $x = w$ and from $y = 0$ to $y = h$.

Section 24.2 Gauss's Law

7. An uncharged, nonconducting, hollow sphere of radius 10.0 cm surrounds a $10.0\text{-}\mu\text{C}$ charge located at the origin of a Cartesian coordinate system. A drill with a radius of 1.00 mm is aligned along the z axis, and a hole is drilled in the sphere. Calculate the electric flux through the hole.
8. Find the net electric flux through the spherical closed surface shown in Figure P24.8. The two charges on the right are inside the spherical surface.

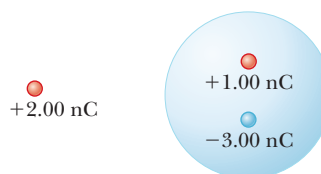

Figure P24.8

9. The following charges are located inside a submarine: $5.00 \mu\text{C}$, $-9.00 \mu\text{C}$, $27.0 \mu\text{C}$, and $-84.0 \mu\text{C}$. (a) Calculate the net electric flux through the hull of the submarine. (b) Is the number of electric field lines leaving the submarine greater than, equal to, or less than the number entering it?
10. The electric field everywhere on the surface of a thin, spherical shell of radius 0.750 m is of magnitude 890 N/C and points radially toward the center of the sphere. (a) What is the net charge within the sphere's surface? (b) What is the distribution of the charge inside the spherical shell?

11. Four closed surfaces, S_1 through S_4 , together with the charges $-2Q$, Q , and $-Q$ are sketched in Figure P24.11. (The colored lines are the intersections of the surfaces with the page.) Find the electric flux through each surface.

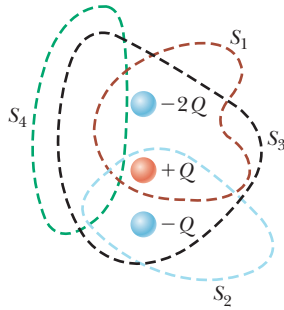

Figure P24.11

12. A charge of $170 \mu\text{C}$ is at the center of a cube of edge 80.0 cm . No other charges are nearby. (a) Find the flux through each face of the cube. (b) Find the flux through the whole surface of the cube. (c) **What If?** Would your answers to either part (a) or part (b) change if the charge were not at the center? Explain.
13. In the air over a particular region at an altitude of 500 m above the ground, the electric field is 120 N/C directed downward. At 600 m above the ground, the electric field is 100 N/C downward. What is the average volume charge density in the layer of air between these two elevations? Is it positive or negative?
14. A particle with charge of $12.0 \mu\text{C}$ is placed at the center of a spherical shell of radius 22.0 cm . What is the total electric flux through (a) the surface of the shell and (b) any hemispherical surface of the shell? (c) Do the results depend on the radius? Explain.

15. (a) Find the net electric flux through the cube shown in Figure P24.15. (b) Can you use Gauss's law to find the electric field on the surface of this cube? Explain.

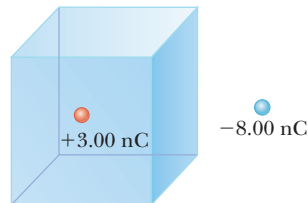

Figure P24.15

16. (a) A particle with charge q is located a distance d from an infinite plane. Determine the electric flux through the plane due to the charged particle. (b) **What If?** A particle with charge q is located a *very small* distance from the center of a *very large* square on the line perpendicular to the square and going through its center. Determine the approximate electric flux through the square due to the charged particle. (c) How do the answers to parts (a) and (b) compare? Explain.

17. An infinitely long line charge having a uniform charge per unit length λ lies a distance d from point O as shown in Figure P24.17. Determine the total electric flux through the surface of a sphere of radius R centered at O resulting from this line charge. Consider both cases, where (a) $R < d$ and (b) $R > d$.

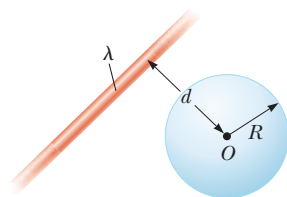

Figure P24.17

18. Find the net electric flux through (a) the closed spherical surface in a uniform electric field shown in Figure P24.18a and (b) the closed cylindrical surface shown in Figure P24.18b. (c) What can you conclude about the charges, if any, inside the cylindrical surface?

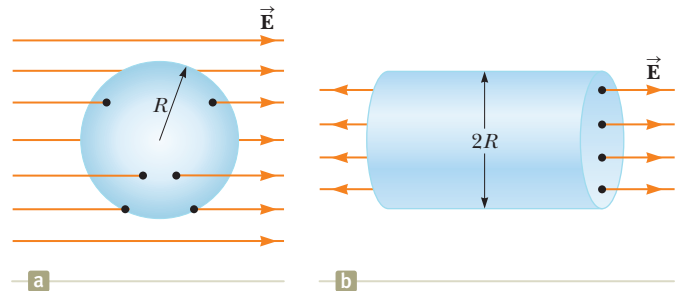

Figure P24.18

19. A particle with charge $Q = 5.00 \mu\text{C}$ is located at the center of a cube of edge $L = 0.100 \text{ m}$. In addition, six other identical charged particles having $q = -1.00 \mu\text{C}$ are positioned symmetrically around Q as shown in Figure P24.19. Determine the electric flux through one face of the cube.

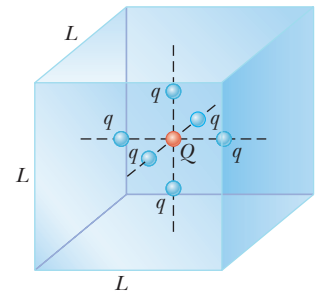

Figure P24.19

Problems 19 and 20.

20. A particle with charge Q is located at the center of a cube of edge L . In addition, six other identical charged particles q are positioned symmetrically around Q as shown in Figure P24.19. For each of these particles, q is a negative number. Determine the electric flux through one face of the cube.

21. A particle with charge Q is located a small distance δ immediately above the center of the flat face of a hemisphere of radius R as shown in Figure P24.21. What is the electric flux (a) through the curved surface and (b) through the flat face as $\delta \rightarrow 0$?

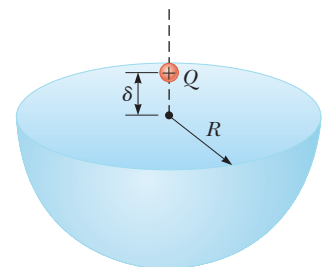

Figure P24.21

22. Figure P24.22 (page 742) represents the top view of a cubic gaussian surface in a uniform electric field \vec{E} oriented parallel to the top and bottom faces of the cube. The field makes an angle θ with side ①, and the area of each face is A . In symbolic form, find the electric flux through (a) face ①, (b) face ②, (c) face ③, (d) face ④, and (e) the top and bottom faces of the cube. (f) What

is the net electric flux through the cube? (g) How much charge is enclosed within the gaussian surface?

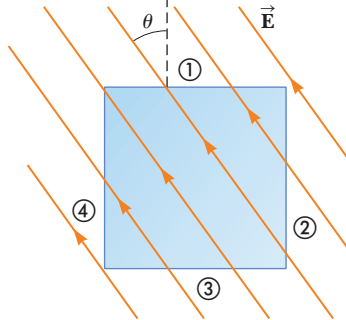

Figure P24.22

Section 24.3 Application of Gauss's Law to Various Charge Distributions

23. In nuclear fission, a nucleus of uranium-238, which contains 92 protons, can divide into two smaller spheres, each having 46 protons and a radius of 5.90×10^{-15} m. What is the magnitude of the repulsive electric force pushing the two spheres apart?

24. The charge per unit length on a long, straight filament is $-90.0 \mu\text{C}/\text{m}$. Find the electric field (a) 10.0 cm, (b) 20.0 cm, and (c) 100 cm from the filament, where distances are measured perpendicular to the length of the filament.

25. A 10.0-g piece of Styrofoam carries a net charge of $-0.700 \mu\text{C}$ and is suspended in equilibrium above the center of a large, horizontal sheet of plastic that has a uniform charge density on its surface. What is the charge per unit area on the plastic sheet?

26. Determine the magnitude of the electric field at the surface of a lead-208 nucleus, which contains 82 protons and 126 neutrons. Assume the lead nucleus has a volume 208 times that of one proton and consider a proton to be a sphere of radius 1.20×10^{-15} m.

27. A large, flat, horizontal sheet of charge has a charge per unit area of $9.00 \mu\text{C}/\text{m}^2$. Find the electric field just above the middle of the sheet.

28. Suppose you fill two rubber balloons with air, suspend both of them from the same point, and let them hang down on strings of equal length. You then rub each with wool or on your hair so that the balloons hang apart with a noticeable separation between them. Make order-of-magnitude estimates of (a) the force on each, (b) the charge on each, (c) the field each creates at the center of the other, and (d) the total flux of electric field created by each balloon. In your solution, state the quantities you take as data and the values you measure or estimate for them.

29. Consider a thin, spherical shell of radius 14.0 cm with a total charge of $32.0 \mu\text{C}$ distributed uniformly on its surface. Find the electric field (a) 10.0 cm and (b) 20.0 cm from the center of the charge distribution.

30. A nonconducting wall carries charge with a uniform density of $8.60 \mu\text{C}/\text{cm}^2$. (a) What is the electric field 7.00 cm in front of the wall if 7.00 cm is small compared

with the dimensions of the wall? (b) Does your result change as the distance from the wall varies? Explain.

31. A uniformly charged, straight filament 7.00 m in length has a total positive charge of $2.00 \mu\text{C}$. An uncharged cardboard cylinder 2.00 cm in length and 10.0 cm in radius surrounds the filament at its center, with the filament as the axis of the cylinder. Using reasonable approximations, find (a) the electric field at the surface of the cylinder and (b) the total electric flux through the cylinder.

32. Assume the magnitude of the electric field on each face of the cube of edge $L = 1.00$ m in Figure P24.32 is uniform and the directions of the fields on each face are as indicated. Find (a) the net electric flux through the cube and (b) the net charge inside the cube. (c) Could the net charge be a single point charge?

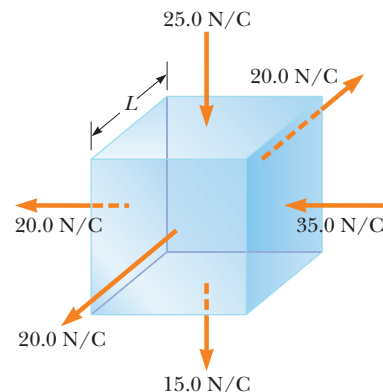

Figure P24.32

33. Consider a long, cylindrical charge distribution of radius R with a uniform charge density ρ . Find the electric field at distance r from the axis, where $r < R$.

34. A cylindrical shell of radius 7.00 cm and length 2.40 m has its charge uniformly distributed on its curved surface. The magnitude of the electric field at a point 19.0 cm radially outward from its axis (measured from the midpoint of the shell) is $36.0 \text{ kN}/\text{C}$. Find (a) the net charge on the shell and (b) the electric field at a point 4.00 cm from the axis, measured radially outward from the midpoint of the shell.

35. A solid sphere of radius 40.0 cm has a total positive charge of $26.0 \mu\text{C}$ uniformly distributed throughout its volume. Calculate the magnitude of the electric field (a) 0 cm, (b) 10.0 cm, (c) 40.0 cm, and (d) 60.0 cm from the center of the sphere.

36. Review. A particle with a charge of -60.0 nC is placed at the center of a nonconducting spherical shell of inner radius 20.0 cm and outer radius 25.0 cm. The spherical shell carries charge with a uniform density of $-1.33 \mu\text{C}/\text{m}^3$. A proton moves in a circular orbit just outside the spherical shell. Calculate the speed of the proton.

Section 24.4 Conductors in Electrostatic Equilibrium

37. A long, straight metal rod has a radius of 5.00 cm and a charge per unit length of $30.0 \text{ nC}/\text{m}$. Find the electric field (a) 3.00 cm, (b) 10.0 cm, and (c) 100 cm from the

axis of the rod, where distances are measured perpendicular to the rod's axis.

38. Why is the following situation impossible? A solid copper sphere of radius 15.0 cm is in electrostatic equilibrium and carries a charge of 40.0 nC. Figure P24.38 shows the magnitude of the electric field as a function of radial position r measured from the center of the sphere.

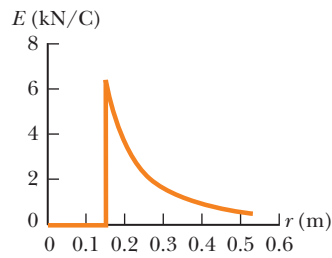

Figure P24.38

39. A solid metallic sphere of radius a carries total charge Q . No other charges are nearby. The electric field just outside its surface is $k_e Q/a^2$ radially outward. At this close point, the uniformly charged surface of the sphere looks exactly like a uniform flat sheet of charge. Is the electric field here given by σ/ϵ_0 or by $\sigma/2\epsilon_0$?
40. A positively charged particle is at a distance $R/2$ from the center of an uncharged thin, conducting, spherical shell of radius R . Sketch the electric field lines set up by this arrangement both inside and outside the shell.
41. A very large, thin, flat plate of aluminum of area A has a total charge Q uniformly distributed over its surfaces. Assuming the same charge is spread uniformly over the upper surface of an otherwise identical glass plate, compare the electric fields just above the center of the upper surface of each plate.
42. In a certain region of space, the electric field is $\vec{E} = 6.00 \times 10^3 x^2 \hat{i}$, where \vec{E} is in newtons per coulomb and x is in meters. Electric charges in this region are at rest and remain at rest. (a) Find the volume density of electric charge at $x = 0.300$ m. *Suggestion:* Apply Gauss's law to a box between $x = 0.300$ m and $x = 0.300$ m + dx . (b) Could this region of space be inside a conductor?
43. Two identical conducting spheres each having a radius of 0.500 cm are connected by a light, 2.00-m-long conducting wire. A charge of 60.0 μC is placed on one of the conductors. Assume the surface distribution of charge on each sphere is uniform. Determine the tension in the wire.
44. A square plate of copper with 50.0-cm sides has no net charge and is placed in a region of uniform electric field of 80.0 kN/C directed perpendicularly to the plate. Find (a) the charge density of each face of the plate and (b) the total charge on each face.
45. A long, straight wire is surrounded by a hollow metal cylinder whose axis coincides with that of the wire. The wire has a charge per unit length of λ , and the cylinder has a net charge per unit length of 2λ . From this information, use Gauss's law to find (a) the charge per unit length on the inner surface of the cylinder, (b) the charge per unit length on the outer surface of the cylinder, and (c) the electric field outside the cylinder a distance r from the axis.
46. A thin, square, conducting plate 50.0 cm on a side lies in the xy plane. A total charge of 4.00×10^{-8} C is placed

on the plate. Find (a) the charge density on each face of the plate, (b) the electric field just above the plate, and (c) the electric field just below the plate. You may assume the charge density is uniform.

47. A solid conducting sphere of radius 2.00 cm has a charge of 8.00 μC . A conducting spherical shell of inner radius 4.00 cm and outer radius 5.00 cm is concentric with the solid sphere and has a charge of $-4.00 \mu\text{C}$. Find the electric field at (a) $r = 1.00$ cm, (b) $r = 3.00$ cm, (c) $r = 4.50$ cm, and (d) $r = 7.00$ cm from the center of this charge configuration.

Additional Problems

48. Consider a plane surface in a uniform electric field as in Figure P24.48, where $d = 15.0$ cm and $\theta = 70.0^\circ$. If the net flux through the surface is $6.00 \text{ N} \cdot \text{m}^2/\text{C}$, find the magnitude of the electric field.

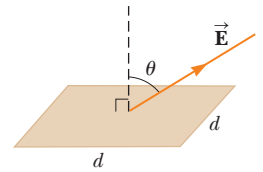

Figure P24.48

Problems 48 and 49.

49. Find the electric flux through the plane surface shown in Figure P24.48 if $\theta = 60.0^\circ$, $E = 350 \text{ N/C}$, and $d = 5.00$ cm. The electric field is uniform over the entire area of the surface.
50. A hollow, metallic, spherical shell has exterior radius 0.750 m, carries no net charge, and is supported on an insulating stand. The electric field everywhere just outside its surface is 890 N/C radially toward the center of the sphere. Explain what you can conclude about (a) the amount of charge on the exterior surface of the sphere and the distribution of this charge, (b) the amount of charge on the interior surface of the sphere and its distribution, and (c) the amount of charge inside the shell and its distribution.

51. A sphere of radius $R = 1.00$ m surrounds a particle with charge $Q = 50.0 \mu\text{C}$ located at its center as shown in Figure P24.51. Find the electric flux through a circular cap of half-angle $\theta = 45.0^\circ$.

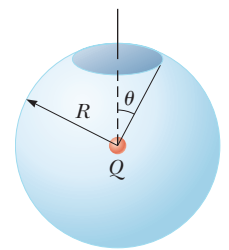

Figure P24.51

Problems 51 and 52.

52. A sphere of radius R surrounds a particle with charge Q located at its center as shown in Figure P24.51. Find the electric flux through a circular cap of half-angle θ .

53. A very large conducting plate lying in the xy plane carries a charge per unit area of σ . A second such plate located above the first plate at $z = z_0$ and oriented parallel to the xy plane carries a charge per unit area of -2σ . Find the electric field for (a) $z < 0$, (b) $0 < z < z_0$, and (c) $z > z_0$.

54. A solid, insulating sphere of radius a has a uniform charge density throughout its volume and a total charge Q . Concentric with this sphere is an uncharged, conducting, hollow sphere whose inner and outer radii are b and c as shown in Figure P24.54 (page 744). We wish to

understand completely the charges and electric fields at all locations. (a) Find the charge contained within a sphere of radius $r < a$. (b) From this value, find the magnitude of the electric field for $r < a$. (c) What charge is contained within a sphere of radius r when $a < r < b$? (d) From this value, find the magnitude of the electric field for r when $a < r < b$. (e) Now consider r when $b < r < c$. What is the magnitude of the electric field for this range of values of r ? (f) From this value, what must be the charge on the inner surface of the hollow sphere?

(g) From part (f), what must be the charge on the outer surface of the hollow sphere? (h) Consider the three spherical surfaces of radii a , b , and c . Which of these surfaces has the largest magnitude of surface charge density?

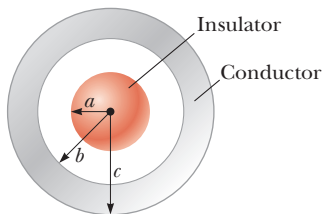

Figure P24.54

Problems 54, 55, and 57.

55. A solid insulating sphere of radius $a = 5.00$ cm carries a net positive charge of $Q = 3.00$ μC uniformly distributed throughout its volume. Concentric with this sphere is a conducting spherical shell with inner radius $b = 10.0$ cm and outer radius $c = 15.0$ cm as shown in Figure P24.54, having net charge $q = -1.00$ μC . Prepare a graph of the magnitude of the electric field due to this configuration versus r for $0 < r < 25.0$ cm.

56. Two infinite, nonconducting sheets of charge are parallel to each other as shown in Figure P24.56. The sheet on the left has a uniform surface charge density σ , and the one on the right has a uniform charge density $-\sigma$. Calculate the electric field at points (a) to the left of, (b) in between, and (c) to the right of the two sheets. (d) **What If?** Find the electric fields in all three regions if both sheets have positive uniform surface charge densities of value σ .

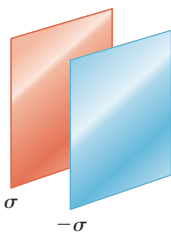

Figure P24.56

57. For the configuration shown in Figure P24.54, suppose $a = 5.00$ cm, $b = 20.0$ cm, and $c = 25.0$ cm. Furthermore, suppose the electric field at a point 10.0 cm from the center is measured to be 3.60×10^3 N/C radially inward and the electric field at a point 50.0 cm from the center is of magnitude 200 N/C and points radially outward. From this information, find (a) the charge on the insulating sphere, (b) the net charge on the hollow conducting sphere, (c) the charge on the inner surface of the hollow conducting sphere, and (d) the charge on the outer surface of the hollow conducting sphere.

58. An insulating solid sphere of radius a has a uniform volume charge density and carries a total positive charge Q . A spherical gaussian surface of radius r , which shares a common center with the insulating sphere, is inflated starting from $r = 0$. (a) Find an expression for the electric flux passing through the surface of the gaussian sphere as a function of r for $r < a$. (b) Find an expression for the electric flux for $r > a$. (c) Plot the flux versus r .

59. A uniformly charged spherical shell with positive surface charge density σ contains a circular hole in its surface. The radius r of the hole is small compared with the radius R of the sphere. What is the electric field at the center of the hole? *Suggestion:* This problem can be solved by using the principle of superposition.

60. An infinitely long, cylindrical, insulating shell of inner radius a and outer radius b has a uniform volume charge density ρ . A line of uniform linear charge density λ is placed along the axis of the shell. Determine the electric field for (a) $r < a$, (b) $a < r < b$, and (c) $r > b$.

Challenge Problems

61. A slab of insulating material has a nonuniform positive charge density $\rho = Cx^2$, where x is measured from the center of the slab as shown in Figure P24.61 and C is a constant. The slab is infinite in the y and z directions. Derive expressions for the electric field in (a) the exterior regions ($|x| > d/2$) and (b) the interior region of the slab ($-d/2 < x < d/2$).

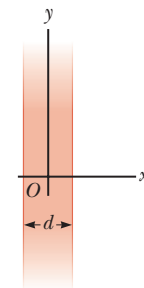

Figure P24.61

Problems 61 and 69.

62. **Review.** An early (incorrect) model of the hydrogen atom, suggested by J. J. Thomson, proposed that a positive cloud of charge $+e$ was uniformly distributed throughout the volume of a sphere of radius R , with the electron (an equal-magnitude negatively charged particle $-e$) at the center. (a) Using Gauss's law, show that the electron would be in equilibrium at the center and, if displaced from the center a distance $r < R$, would experience a restoring force of the form $F = -Kr$, where K is a constant. (b) Show that $K = k_e e^2 / R^3$. (c) Find an expression for the frequency f of simple harmonic oscillations that an electron of mass m_e would undergo if displaced a small distance ($< R$) from the center and released. (d) Calculate a numerical value for R that would result in a frequency of 2.47×10^{15} Hz, the frequency of the light radiated in the most intense line in the hydrogen spectrum.

63. A closed surface with dimensions $a = b = 0.400$ m and $c = 0.600$ m is located as shown in Figure P24.63. The left edge of the closed surface is located at position $x = a$. The electric field throughout the region is non-uniform and is given by $\vec{E} = (3.00 + 2.00x^2)\hat{i}$ N/C, where x is in meters. (a) Calculate the net electric flux

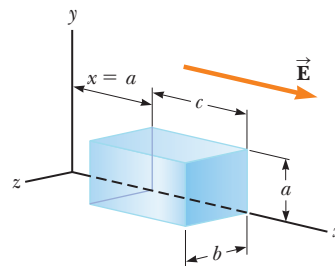

Figure P24.63

leaving the closed surface. (b) What net charge is enclosed by the surface?

- 64.** A sphere of radius $2a$ is made of a nonconducting material that has a uniform volume charge density ρ . Assume the material does not affect the electric field. A spherical cavity of radius a is now removed from the sphere as shown in Figure P24.64. Show that the electric field within the cavity is uniform and is given by $E_x = 0$ and $E_y = \rho a/3\epsilon_0$.

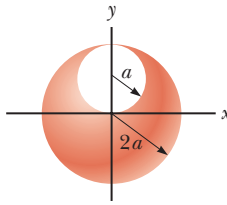

Figure P24.64

- 65.** A spherically symmetric charge distribution has a charge density given by $\rho = a/r$, where a is constant. Find the electric field within the charge distribution as a function of r . *Note:* The volume element dV for a spherical shell of radius r and thickness dr is equal to $4\pi r^2 dr$.
- 66.** A solid insulating sphere of radius R has a nonuniform charge density that varies with r according to the expression $\rho = Ar^2$, where A is a constant and $r < R$ is measured from the center of the sphere. (a) Show that the magnitude of the electric field outside ($r > R$) the sphere is $E = AR^5/5\epsilon_0 r^2$. (b) Show that the magnitude of the electric field inside ($r < R$) the sphere is $E = Ar^3/5\epsilon_0$. *Note:* The volume element dV for a spherical shell of radius r and thickness dr is equal to $4\pi r^2 dr$.

- 67.** An infinitely long insulating cylinder of radius R has a volume charge density that varies with the radius as

$$\rho = \rho_0 \left(a - \frac{r}{b} \right)$$

where ρ_0 , a , and b are positive constants and r is the distance from the axis of the cylinder. Use Gauss's law to determine the magnitude of the electric field at radial distances (a) $r < R$ and (b) $r > R$.

- 68.** A particle with charge Q is located on the axis of a circle of radius R at a distance b from the plane of the circle (Fig. P24.68). Show that if one-fourth of the electric flux from the charge passes through the circle, then $R = \sqrt{3}b$.

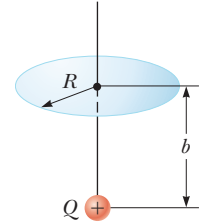

Figure P24.68

- 69. Review.** A slab of insulating material (infinite in the y and z directions) has a thickness d and a uniform positive charge density ρ . An edge view of the slab is shown in Figure P24.61. (a) Show that the magnitude of the electric field a distance x from its center and inside the slab is $E = \rho x/\epsilon_0$. (b) **What If?** Suppose an electron of charge $-e$ and mass m_e can move freely within the slab. It is released from rest at a distance x from the center. Show that the electron exhibits simple harmonic motion with a frequency

$$f = \frac{1}{2\pi} \sqrt{\frac{\rho e}{m_e \epsilon_0}}$$

Electric Potential

- 25.1 Electric Potential and Potential Difference
- 25.2 Potential Difference in a Uniform Electric Field
- 25.3 Electric Potential and Potential Energy Due to Point Charges
- 25.4 Obtaining the Value of the Electric Field from the Electric Potential
- 25.5 Electric Potential Due to Continuous Charge Distributions
- 25.6 Electric Potential Due to a Charged Conductor
- 25.7 The Millikan Oil-Drop Experiment
- 25.8 Applications of Electrostatics



Processes occurring during thunderstorms cause large differences in electric potential between a thundercloud and the ground. The result of this potential difference is an electrical discharge that we call lightning, such as this display. Notice at the left that a downward channel of lightning (a *stepped leader*) is about to make contact with a channel coming up from the ground (a *return stroke*).
(Costazzurra/Shutterstock.com)

In Chapter 23, we linked our new study of electromagnetism to our earlier studies of *force*. Now we make a new link to our earlier investigations into *energy*. The concept of potential energy was introduced in Chapter 7 in connection with such conservative forces as the gravitational force and the elastic force exerted by a spring. By using the law of conservation of energy, we could solve various problems in mechanics that were not solvable with an approach using forces. The concept of potential energy is also of great value in the study of electricity. Because the electrostatic force is conservative, electrostatic phenomena can be conveniently described in terms of an electric potential energy. This idea enables us to define a quantity known as *electric potential*. Because the electric potential at any point in an electric field is a scalar quantity, we can use it to describe electrostatic phenomena more simply than if we were to rely only on the electric field and electric forces. The concept of electric potential is of great practical value in the operation of electric circuits and devices that we will study in later chapters.

25.1 Electric Potential and Potential Difference

When a charge q is placed in an electric field \vec{E} created by some source charge distribution, the particle in a field model tells us that there is an electric force $q\vec{E}$

acting on the charge. This force is conservative because the force between charges described by Coulomb's law is conservative. Let us identify the charge and the field as a system. If the charge is free to move, it will do so in response to the electric force. Therefore, the electric field will be doing work on the charge. This work is *internal* to the system. This situation is similar to that in a gravitational system: When an object is released near the surface of the Earth, the gravitational force does work on the object. This work is internal to the object–Earth system as discussed in Sections 7.7 and 7.8.

When analyzing electric and magnetic fields, it is common practice to use the notation $d\vec{s}$ to represent an infinitesimal displacement vector that is oriented tangent to a path through space. This path may be straight or curved, and an integral performed along this path is called either a *path integral* or a *line integral* (the two terms are synonymous).

For an infinitesimal displacement $d\vec{s}$ of a point charge q immersed in an electric field, the work done within the charge–field system by the electric field on the charge is $W_{\text{int}} = \vec{F}_e \cdot d\vec{s} = q\vec{E} \cdot d\vec{s}$. Recall from Equation 7.26 that internal work done in a system is equal to the negative of the change in the potential energy of the system: $W_{\text{int}} = -\Delta U$. Therefore, as the charge q is displaced, the electric potential energy of the charge–field system is changed by an amount $dU = -W_{\text{int}} = -q\vec{E} \cdot d\vec{s}$. For a finite displacement of the charge from some point \textcircled{A} in space to some other point \textcircled{B} , the change in electric potential energy of the system is

$$\Delta U = -q \int_{\textcircled{A}}^{\textcircled{B}} \vec{E} \cdot d\vec{s} \quad (25.1)$$

The integration is performed along the path that q follows as it moves from \textcircled{A} to \textcircled{B} . Because the force $q\vec{E}$ is conservative, this line integral does not depend on the path taken from \textcircled{A} to \textcircled{B} .

For a given position of the charge in the field, the charge–field system has a potential energy U relative to the configuration of the system that is defined as $U = 0$. Dividing the potential energy by the charge gives a physical quantity that depends only on the source charge distribution and has a value at every point in an electric field. This quantity is called the **electric potential** (or simply the **potential**) V :

$$V = \frac{U}{q} \quad (25.2)$$

Because potential energy is a scalar quantity, electric potential also is a scalar quantity.

The **potential difference** $\Delta V = V_{\textcircled{B}} - V_{\textcircled{A}}$ between two points \textcircled{A} and \textcircled{B} in an electric field is defined as the change in electric potential energy of the system when a charge q is moved between the points (Eq. 25.1) divided by the charge:

$$\Delta V \equiv \frac{\Delta U}{q} = - \int_{\textcircled{A}}^{\textcircled{B}} \vec{E} \cdot d\vec{s} \quad (25.3)$$

In this definition, the infinitesimal displacement $d\vec{s}$ is interpreted as the displacement between two points in space rather than the displacement of a point charge as in Equation 25.1.

Just as with potential energy, only *differences* in electric potential are meaningful. We often take the value of the electric potential to be zero at some convenient point in an electric field.

Potential difference should not be confused with difference in potential energy. The potential *difference* between \textcircled{A} and \textcircled{B} exists solely because of a source charge and depends on the source charge distribution (consider points \textcircled{A} and \textcircled{B} in the discussion above *without* the presence of the charge q). For a potential *energy* to exist, we must have a system of two or more charges. The potential

◀ Change in electric potential energy of a system

Pitfall Prevention 25.1

Potential and Potential Energy

The *potential* is characteristic of the field only, independent of a charged particle that may be placed in the field. *Potential energy* is characteristic of the charge–field system due to an interaction between the field and a charged particle placed in the field.

◀ Potential difference between two points

Pitfall Prevention 25.2

Voltage A variety of phrases are used to describe the potential difference between two points, the most common being **voltage**, arising from the unit for potential. A voltage *applied* to a device, such as a television, or *across* a device is the same as the potential difference across the device. Despite popular language, voltage is *not* something that moves *through* a device.

Pitfall Prevention 25.3

The Electron Volt The electron volt is a unit of *energy*, NOT of potential. The energy of any system may be expressed in eV, but this unit is most convenient for describing the emission and absorption of visible light from atoms. Energies of nuclear processes are often expressed in MeV.

energy belongs to the system and changes only if a charge is moved relative to the rest of the system. This situation is similar to that for the electric field. An electric *field* exists solely because of a source charge. An electric *force* requires two charges: the source charge to set up the field and another charge placed within that field.

Let's now consider the situation in which an external agent moves the charge in the field. If the agent moves the charge from Ⓐ to Ⓑ without changing the kinetic energy of the charge, the agent performs work that changes the potential energy of the system: $W = \Delta U$. From Equation 25.3, the work done by an external agent in moving a charge q through an electric field at constant velocity is

$$W = q \Delta V \quad (25.4)$$

Because electric potential is a measure of potential energy per unit charge, the SI unit of both electric potential and potential difference is joules per coulomb, which is defined as a **volt** (V):

$$1 \text{ V} \equiv 1 \text{ J/C}$$

That is, as we can see from Equation 25.4, 1 J of work must be done to move a 1-C charge through a potential difference of 1 V.

Equation 25.3 shows that potential difference also has units of electric field times distance. It follows that the SI unit of electric field (N/C) can also be expressed in volts per meter:

$$1 \text{ N/C} = 1 \text{ V/m}$$

Therefore, we can state a new interpretation of the electric field:

The electric field is a measure of the rate of change of the electric potential with respect to position.

A unit of energy commonly used in atomic and nuclear physics is the **electron volt** (eV), which is defined as the energy a charge–field system gains or loses when a charge of magnitude e (that is, an electron or a proton) is moved through a potential difference of 1 V. Because $1 \text{ V} = 1 \text{ J/C}$ and the fundamental charge is equal to $1.60 \times 10^{-19} \text{ C}$, the electron volt is related to the joule as follows:

$$1 \text{ eV} = 1.60 \times 10^{-19} \text{ C} \cdot \text{V} = 1.60 \times 10^{-19} \text{ J} \quad (25.5)$$

For instance, an electron in the beam of a typical dental x-ray machine may have a speed of $1.4 \times 10^8 \text{ m/s}$. This speed corresponds to a kinetic energy $1.1 \times 10^{-14} \text{ J}$ (using relativistic calculations as discussed in Chapter 39), which is equivalent to $6.7 \times 10^4 \text{ eV}$. Such an electron has to be accelerated from rest through a potential difference of 67 kV to reach this speed.

- Quick Quiz 25.1** In Figure 25.1, two points Ⓐ and Ⓑ are located within a region in which there is an electric field. (i) How would you describe the potential difference $\Delta V = V_{\text{Ⓑ}} - V_{\text{Ⓐ}}$? (a) It is positive. (b) It is negative. (c) It is zero. (ii) A negative charge is placed at Ⓐ and then moved to Ⓑ. How would you describe the change in potential energy of the charge–field system for this process? Choose from the same possibilities.

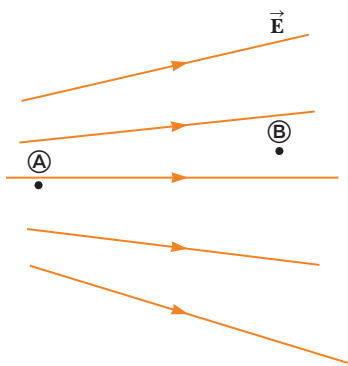

Figure 25.1 (Quick Quiz 25.1)
Two points in an electric field.

25.2 Potential Difference in a Uniform Electric Field

Equations 25.1 and 25.3 hold in all electric fields, whether uniform or varying, but they can be simplified for the special case of a uniform field. First, consider a uniform electric field directed along the negative y axis as shown in Figure 25.2a. Let's calculate the potential difference between two points Ⓐ and Ⓑ separated by a dis-

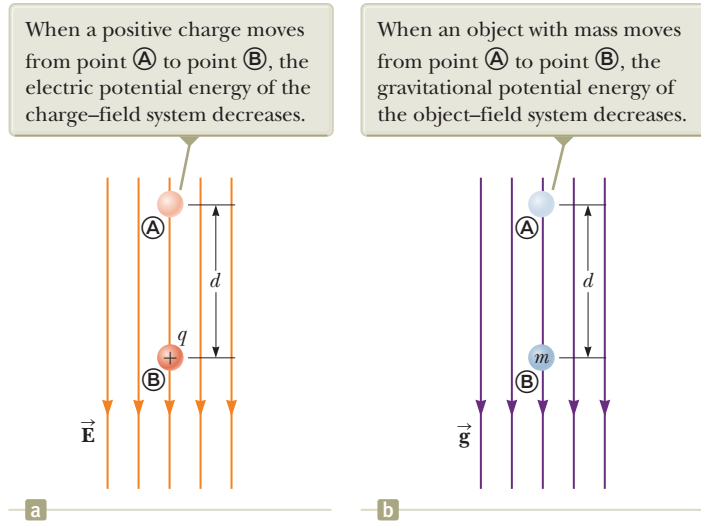

Figure 25.2 (a) When the electric field \vec{E} is directed downward, point \textcircled{B} is at a lower electric potential than point \textcircled{A} . (b) A gravitational analog to the situation in (a).

tance d , where the displacement \vec{s} points from \textcircled{A} toward \textcircled{B} and is parallel to the field lines. Equation 25.3 gives

$$V_{\textcircled{B}} - V_{\textcircled{A}} = \Delta V = -\int_{\textcircled{A}}^{\textcircled{B}} \vec{E} \cdot d\vec{s} = -\int_{\textcircled{A}}^{\textcircled{B}} E ds (\cos 0^\circ) = -\int_{\textcircled{A}}^{\textcircled{B}} E ds$$

Because E is constant, it can be removed from the integral sign, which gives

$$\Delta V = -E \int_{\textcircled{A}}^{\textcircled{B}} ds$$

$$\Delta V = -Ed \quad (25.6)$$

The negative sign indicates that the electric potential at point \textcircled{B} is lower than at point \textcircled{A} ; that is, $V_{\textcircled{B}} < V_{\textcircled{A}}$. Electric field lines *always* point in the direction of decreasing electric potential as shown in Figure 25.2a.

Now suppose a charge q moves from \textcircled{A} to \textcircled{B} . We can calculate the change in the potential energy of the charge–field system from Equations 25.3 and 25.6:

$$\Delta U = q \Delta V = -qEd \quad (25.7)$$

This result shows that if q is positive, then ΔU is negative. Therefore, in a system consisting of a positive charge and an electric field, the electric potential energy of the system decreases when the charge moves in the direction of the field. If a positive charge is released from rest in this electric field, it experiences an electric force $q\vec{E}$ in the direction of \vec{E} (downward in Fig. 25.2a). Therefore, it accelerates downward, gaining kinetic energy. As the charged particle gains kinetic energy, the electric potential energy of the charge–field system decreases by an equal amount. This equivalence should not be surprising; it is simply conservation of mechanical energy in an isolated system as introduced in Chapter 8.

Figure 25.2b shows an analogous situation with a gravitational field. When a particle with mass m is released in a gravitational field, it accelerates downward, gaining kinetic energy. At the same time, the gravitational potential energy of the object–field system decreases.

The comparison between a system of a positive charge residing in an electrical field and an object with mass residing in a gravitational field in Figure 25.2 is useful for conceptualizing electrical behavior. The electrical situation, however, has one feature that the gravitational situation does not: the charge can be negative. If q is negative, then ΔU in Equation 25.7 is positive and the situation is reversed.

◀ **Potential difference between two points in a uniform electric field**

Pitfall Prevention 25.4

The Sign of ΔV The negative sign in Equation 25.6 is due to the fact that we started at point \textcircled{A} and moved to a new point in the *same* direction as the electric field lines. If we started from \textcircled{B} and moved to \textcircled{A} , the potential difference would be $+Ed$. In a uniform electric field, the magnitude of the potential difference is Ed and the sign can be determined by the direction of travel.

Figure 25.3 A uniform electric field directed along the positive x axis. Three points in the electric field are labeled.

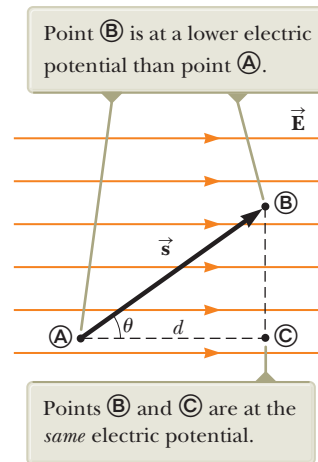

A system consisting of a negative charge and an electric field *gains* electric potential energy when the charge moves in the direction of the field. If a negative charge is released from rest in an electric field, it accelerates in a direction *opposite* the direction of the field. For the negative charge to move in the direction of the field, an external agent must apply a force and do positive work on the charge.

Now consider the more general case of a charged particle that moves between A and B in a uniform electric field such that the vector \vec{s} is *not* parallel to the field lines as shown in Figure 25.3. In this case, Equation 25.3 gives

$$\Delta V = - \int_{\text{A}}^{\text{B}} \vec{E} \cdot d\vec{s} = - \vec{E} \cdot \int_{\text{A}}^{\text{B}} d\vec{s} = - \vec{E} \cdot \vec{s} \quad (25.8)$$

where again \vec{E} was removed from the integral because it is constant. The change in potential energy of the charge–field system is

$$\Delta U = q\Delta V = -q\vec{E} \cdot \vec{s} \quad (25.9)$$

Finally, we conclude from Equation 25.8 that all points in a plane perpendicular to a uniform electric field are at the same electric potential. We can see that in Figure 25.3, where the potential difference $V_{\text{B}} - V_{\text{A}}$ is equal to the potential difference $V_{\text{C}} - V_{\text{A}}$. (Prove this fact to yourself by working out two dot products for $\vec{E} \cdot \vec{s}$: one for $\vec{s}_{\text{A} \rightarrow \text{B}}$, where the angle θ between \vec{E} and \vec{s} is arbitrary as shown in Figure 25.3, and one for $\vec{s}_{\text{A} \rightarrow \text{C}}$, where $\theta = 0$.) Therefore, $V_{\text{B}} = V_{\text{C}}$. The name **equipotential surface** is given to any surface consisting of a continuous distribution of points having the same electric potential.

The equipotential surfaces associated with a uniform electric field consist of a family of parallel planes that are all perpendicular to the field. Equipotential surfaces associated with fields having other symmetries are described in later sections.

Quick Quiz 25.2 The labeled points in Figure 25.4 are on a series of equipotential surfaces associated with an electric field. Rank (from greatest to least) the work done by the electric field on a positively charged particle that moves from

- A to B, from B to C, from C to D, and from D to E.

Change in potential between two points in a uniform electric field

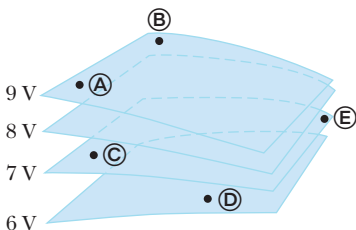

Figure 25.4 (Quick Quiz 25.2) Four equipotential surfaces.

Example 25.1 The Electric Field Between Two Parallel Plates of Opposite Charge

A battery has a specified potential difference ΔV between its terminals and establishes that potential difference between conductors attached to the terminals. A 12-V battery is connected between two parallel plates as shown in Figure 25.5. The separation between the plates is $d = 0.30$ cm, and we assume the electric field between the plates to be uniform. (This assumption is reasonable if the plate separation is small relative to the plate dimensions and we do not consider locations near the plate edges.) Find the magnitude of the electric field between the plates.

25.1 continued

Figure 25.5 (Example 25.1) A 12-V battery connected to two parallel plates. The electric field between the plates has a magnitude given by the potential difference ΔV divided by the plate separation d .

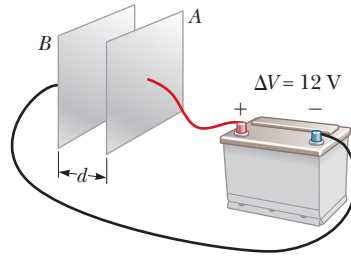

SOLUTION

Conceptualize In Example 24.5, we illustrated the uniform electric field between parallel plates. The new feature to this problem is that the electric field is related to the new concept of electric potential.

Categorize The electric field is evaluated from a relationship between field and potential given in this section, so we categorize this example as a substitution problem.

Use Equation 25.6 to evaluate the magnitude of the electric field between the plates:

$$E = \frac{|V_B - V_A|}{d} = \frac{12 \text{ V}}{0.30 \times 10^{-2} \text{ m}} = 4.0 \times 10^3 \text{ V/m}$$

The configuration of plates in Figure 25.5 is called a *parallel-plate capacitor* and is examined in greater detail in Chapter 26.

Example 25.2 Motion of a Proton in a Uniform Electric Field

AM

A proton is released from rest at point **A** in a uniform electric field that has a magnitude of $8.0 \times 10^4 \text{ V/m}$ (Fig. 25.6). The proton undergoes a displacement of magnitude $d = 0.50 \text{ m}$ to point **B** in the direction of \vec{E} . Find the speed of the proton after completing the displacement.

SOLUTION

Conceptualize Visualize the proton in Figure 25.6 moving downward through the potential difference. The situation is analogous to an object falling through a gravitational field. Also compare this example to Example 23.10 where a positive charge was moving in a uniform electric field. In that example, we applied the particle under constant acceleration and nonisolated system models. Now that we have investigated electric potential energy, what model can we use here?

Categorize The system of the proton and the two plates in Figure 25.6 does not interact with the environment, so we model it as an *isolated system for energy*.

Analyze

Write the appropriate reduction of Equation 8.2, the conservation of energy equation, for the isolated system of the charge and the electric field:

$$\Delta K + \Delta U = 0$$

Substitute the changes in energy for both terms:

$$\left(\frac{1}{2}mv^2 - 0\right) + e\Delta V = 0$$

Solve for the final speed of the proton and substitute for ΔV from Equation 25.6:

$$v = \sqrt{\frac{-2e\Delta V}{m}} = \sqrt{\frac{-2e(-Ed)}{m}} = \sqrt{\frac{2eEd}{m}}$$

Substitute numerical values:

$$v = \sqrt{\frac{2(1.6 \times 10^{-19} \text{ C})(8.0 \times 10^4 \text{ V})(0.50 \text{ m})}{1.67 \times 10^{-27} \text{ kg}}} \\ = 2.8 \times 10^6 \text{ m/s}$$

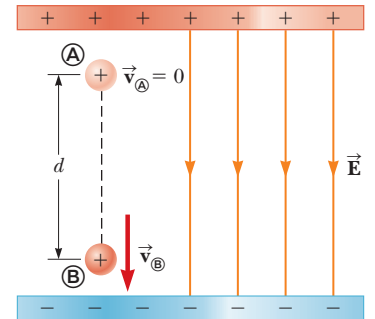

Figure 25.6 (Example 25.2) A proton accelerates from **A** to **B** in the direction of the electric field.

continued

25.2 continued

Finalize Because ΔV is negative for the field, ΔU is also negative for the proton–field system. The negative value of ΔU means the potential energy of the system decreases as the proton moves in the direction of the electric field. As the proton accelerates in the direction of the field, it gains kinetic energy while the electric potential energy of the system decreases at the same time.

Figure 25.6 is oriented so that the proton moves downward. The proton's motion is analogous to that of an object falling in a gravitational field. Although the gravitational field is always downward at the surface of the Earth, an electric field can be in any direction, depending on the orientation of the plates creating the field. Therefore, Figure 25.6 could be rotated 90° or 180° and the proton could move horizontally or upward in the electric field!

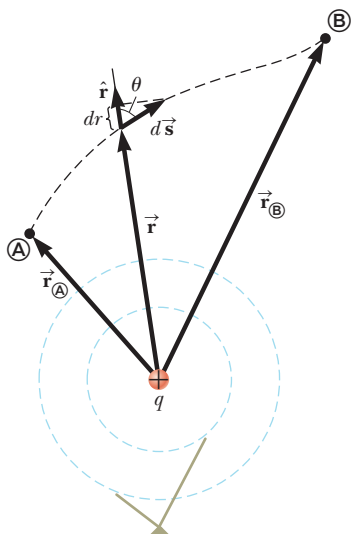

The two dashed circles represent intersections of spherical equipotential surfaces with the page.

Figure 25.7 The potential difference between points **A** and **B** due to a point charge q depends *only* on the initial and final radial coordinates r_A and r_B .

Pitfall Prevention 25.5

Similar Equation Warning Do not confuse Equation 25.11 for the electric potential of a point charge with Equation 23.9 for the electric field of a point charge. Potential is proportional to $1/r$, whereas the magnitude of the field is proportional to $1/r^2$. The effect of a charge on the space surrounding it can be described in two ways. The charge sets up a vector electric field \vec{E} , which is related to the force experienced by a charge placed in the field. It also sets up a scalar potential V , which is related to the potential energy of the two-charge system when a charge is placed in the field.

25.3 Electric Potential and Potential Energy Due to Point Charges

As discussed in Section 23.4, an isolated positive point charge q produces an electric field directed radially outward from the charge. To find the electric potential at a point located a distance r from the charge, let's begin with the general expression for potential difference, Equation 25.3,

$$V_B - V_A = - \int_A^B \vec{E} \cdot d\vec{s}$$

where **A** and **B** are the two arbitrary points shown in Figure 25.7. At any point in space, the electric field due to the point charge is $\vec{E} = (k_e q/r^2) \hat{r}$ (Eq. 23.9), where \hat{r} is a unit vector directed radially outward from the charge. Therefore, the quantity $\vec{E} \cdot d\vec{s}$ can be expressed as

$$\vec{E} \cdot d\vec{s} = k_e \frac{q}{r^2} \hat{r} \cdot d\vec{s}$$

Because the magnitude of \hat{r} is 1, the dot product $\hat{r} \cdot d\vec{s} = ds \cos \theta$, where θ is the angle between \hat{r} and $d\vec{s}$. Furthermore, $ds \cos \theta$ is the projection of $d\vec{s}$ onto \hat{r} ; therefore, $ds \cos \theta = dr$. That is, any displacement $d\vec{s}$ along the path from point **A** to point **B** produces a change dr in the magnitude of \vec{r} , the position vector of the point relative to the charge creating the field. Making these substitutions, we find that $\vec{E} \cdot d\vec{s} = (k_e q/r^2) dr$; hence, the expression for the potential difference becomes

$$V_B - V_A = -k_e q \int_{r_A}^{r_B} \frac{dr}{r^2} = k_e \frac{q}{r} \Big|_{r_A}^{r_B}$$

$$V_B - V_A = k_e q \left[\frac{1}{r_B} - \frac{1}{r_A} \right] \quad (25.10)$$

Equation 25.10 shows us that the integral of $\vec{E} \cdot d\vec{s}$ is *independent* of the path between points **A** and **B**. Multiplying by a charge q_0 that moves between points **A** and **B**, we see that the integral of $q_0 \vec{E} \cdot d\vec{s}$ is also independent of path. This latter integral, which is the work done by the electric force on the charge q_0 , shows that the electric force is conservative (see Section 7.7). We define a field that is related to a conservative force as a **conservative field**. Therefore, Equation 25.10 tells us that the electric field of a fixed point charge q is conservative. Furthermore, Equation 25.10 expresses the important result that the potential difference between any two points **A** and **B** in a field created by a point charge depends only on the radial coordinates r_A and r_B . It is customary to choose the reference of electric potential for a point charge to be $V = 0$ at $r_A = \infty$. With this reference choice, the electric potential due to a point charge at any distance r from the charge is

$$V = k_e \frac{q}{r} \quad (25.11)$$

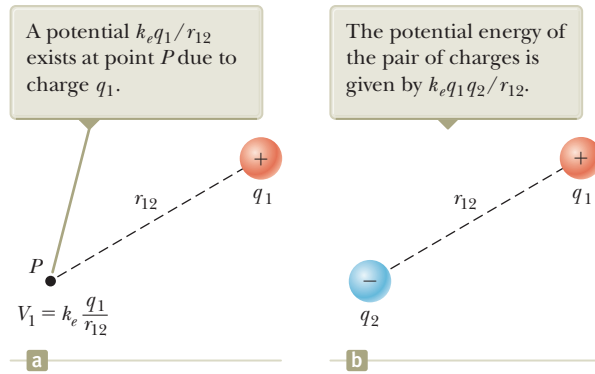

Figure 25.8 (a) Charge q_1 establishes an electric potential V_1 at point P . (b) Charge q_2 is brought from infinity to point P .

We obtain the electric potential resulting from two or more point charges by applying the superposition principle. That is, the total electric potential at some point P due to several point charges is the sum of the potentials due to the individual charges. For a group of point charges, we can write the total electric potential at P as

$$V = k_e \sum_i \frac{q_i}{r_i} \quad (25.12)$$

◀ Electric potential due to several point charges

Figure 25.8a shows a charge q_1 , which sets up an electric field throughout space. The charge also establishes an electric potential at all points, including point P , where the electric potential is V_1 . Now imagine that an external agent brings a charge q_2 from infinity to point P . The work that must be done to do this is given by Equation 25.4, $W = q_2\Delta V$. This work represents a transfer of energy across the boundary of the two-charge system, and the energy appears in the system as potential energy U when the particles are separated by a distance r_{12} as in Figure 25.8b. From Equation 8.2, we have $W = \Delta U$. Therefore, the **electric potential energy** of a pair of point charges¹ can be found as follows:

$$\begin{aligned} \Delta U = W = q_2\Delta V &\rightarrow U - 0 = q_2 \left(k_e \frac{q_1}{r_{12}} - 0 \right) \\ U &= k_e \frac{q_1 q_2}{r_{12}} \end{aligned} \quad (25.13)$$

If the charges are of the same sign, then U is positive. Positive work must be done by an external agent on the system to bring the two charges near each other (because charges of the same sign repel). If the charges are of opposite sign, as in Figure 25.8b, then U is negative. Negative work is done by an external agent against the attractive force between the charges of opposite sign as they are brought near each other; a force must be applied opposite the displacement to prevent q_2 from accelerating toward q_1 .

If the system consists of more than two charged particles, we can obtain the total potential energy of the system by calculating U for every *pair* of charges and summing the terms algebraically. For example, the total potential energy of the system of three charges shown in Figure 25.9 is

$$U = k_e \left(\frac{q_1 q_2}{r_{12}} + \frac{q_1 q_3}{r_{13}} + \frac{q_2 q_3}{r_{23}} \right) \quad (25.14)$$

Physically, this result can be interpreted as follows. Imagine q_1 is fixed at the position shown in Figure 25.9 but q_2 and q_3 are at infinity. The work an external agent must do to bring q_2 from infinity to its position near q_1 is $k_e q_1 q_2 / r_{12}$, which is the first term in Equation 25.14. The last two terms represent the work required to bring q_3 from infinity to its position near q_1 and q_2 . (The result is independent of the order in which the charges are transported.)

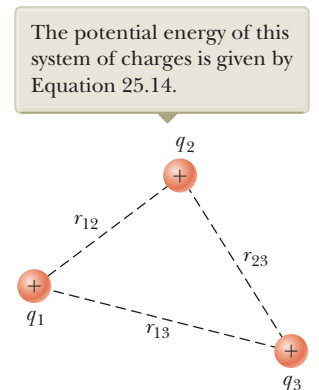

Figure 25.9 Three point charges are fixed at the positions shown.

¹The expression for the electric potential energy of a system made up of two point charges, Equation 25.13, is of the same form as the equation for the gravitational potential energy of a system made up of two point masses, $-Gm_1 m_2 / r$ (see Chapter 13). The similarity is not surprising considering that both expressions are derived from an inverse-square force law.

- Quick Quiz 25.3** In Figure 25.8b, take q_2 to be a negative source charge and q_1 to be a second charge whose sign can be changed. (i) If q_1 is initially positive and is changed to a charge of the same magnitude but negative, what happens to the potential at the position of q_1 due to q_2 ? (a) It increases. (b) It decreases. (c) It remains the same. (ii) When q_1 is changed from positive to negative, what happens to the potential energy of the two-charge system? Choose from the same possibilities.

Example 25.3 The Electric Potential Due to Two Point Charges

As shown in Figure 25.10a, a charge $q_1 = 2.00 \mu\text{C}$ is located at the origin and a charge $q_2 = -6.00 \mu\text{C}$ is located at $(0, 3.00) \text{ m}$.

(A) Find the total electric potential due to these charges at the point P , whose coordinates are $(4.00, 0) \text{ m}$.

SOLUTION

Conceptualize Recognize first that the $2.00\text{-}\mu\text{C}$ and $-6.00\text{-}\mu\text{C}$ charges are source charges and set up an electric field as well as a potential at all points in space, including point P .

Categorize The potential is evaluated using an equation developed in this chapter, so we categorize this example as a substitution problem.

Use Equation 25.12 for the system of two source charges:

$$V_P = k_e \left(\frac{q_1}{r_1} + \frac{q_2}{r_2} \right)$$

Substitute numerical values:

$$\begin{aligned} V_P &= (8.988 \times 10^9 \text{ N} \cdot \text{m}^2/\text{C}^2) \left(\frac{2.00 \times 10^{-6} \text{ C}}{4.00 \text{ m}} + \frac{-6.00 \times 10^{-6} \text{ C}}{5.00 \text{ m}} \right) \\ &= -6.29 \times 10^3 \text{ V} \end{aligned}$$

(B) Find the change in potential energy of the system of two charges plus a third charge $q_3 = 3.00 \mu\text{C}$ as the latter charge moves from infinity to point P (Fig. 25.10b).

SOLUTION

Assign $U_i = 0$ for the system to the initial configuration in which the charge q_3 is at infinity. Use Equation 25.2 to evaluate the potential energy for the configuration in which the charge is at P :

$$U_f = q_3 V_P$$

Substitute numerical values to evaluate ΔU :

$$\begin{aligned} \Delta U &= U_f - U_i = q_3 V_P - 0 = (3.00 \times 10^{-6} \text{ C})(-6.29 \times 10^3 \text{ V}) \\ &= -1.89 \times 10^{-2} \text{ J} \end{aligned}$$

Therefore, because the potential energy of the system has decreased, an external agent has to do positive work to remove the charge q_3 from point P back to infinity.

WHAT IF? You are working through this example with a classmate and she says, “Wait a minute! In part (B), we ignored the potential energy associated with the pair of charges q_1 and q_2 !” How would you respond?

Answer Given the statement of the problem, it is not necessary to include this potential energy because part (B) asks for the *change* in potential energy of the system as q_3 is brought in from infinity. Because the configuration of charges q_1 and q_2 does not change in the process, there is no ΔU associated with these charges. Had part (B) asked to find the change in potential energy when *all three* charges start out infinitely far apart and are then brought to the positions in Figure 25.10b, however, you would have to calculate the change using Equation 25.14.

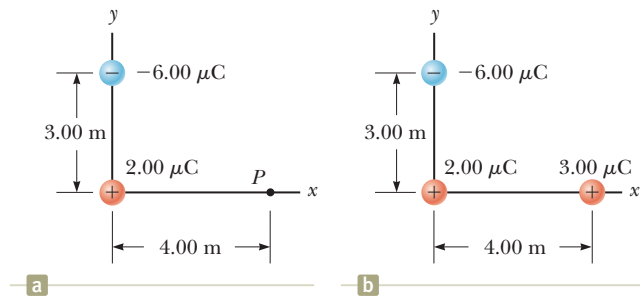

Figure 25.10 (Example 25.3) (a) The electric potential at P due to the two charges q_1 and q_2 is the algebraic sum of the potentials due to the individual charges. (b) A third charge $q_3 = 3.00 \mu\text{C}$ is brought from infinity to point P .

25.4 Obtaining the Value of the Electric Field from the Electric Potential

The electric field $\vec{\mathbf{E}}$ and the electric potential V are related as shown in Equation 25.3, which tells us how to find ΔV if the electric field $\vec{\mathbf{E}}$ is known. What if the situation is reversed? How do we calculate the value of the electric field if the electric potential is known in a certain region?

From Equation 25.3, the potential difference dV between two points a distance ds apart can be expressed as

$$dV = -\vec{\mathbf{E}} \cdot d\vec{\mathbf{s}} \quad (25.15)$$

If the electric field has only one component E_x , then $\vec{\mathbf{E}} \cdot d\vec{\mathbf{s}} = E_x dx$. Therefore, Equation 25.15 becomes $dV = -E_x dx$, or

$$E_x = -\frac{dV}{dx} \quad (25.16)$$

That is, the x component of the electric field is equal to the negative of the derivative of the electric potential with respect to x . Similar statements can be made about the y and z components. Equation 25.16 is the mathematical statement of the electric field being a measure of the rate of change with position of the electric potential as mentioned in Section 25.1.

Experimentally, electric potential and position can be measured easily with a voltmeter (a device for measuring potential difference) and a meterstick. Consequently, an electric field can be determined by measuring the electric potential at several positions in the field and making a graph of the results. According to Equation 25.16, the slope of a graph of V versus x at a given point provides the magnitude of the electric field at that point.

Imagine starting at a point and then moving through a displacement $d\vec{\mathbf{s}}$ along an equipotential surface. For this motion, $dV = 0$ because the potential is constant along an equipotential surface. From Equation 25.15, we see that $dV = -\vec{\mathbf{E}} \cdot d\vec{\mathbf{s}} = 0$; therefore, because the dot product is zero, $\vec{\mathbf{E}}$ must be perpendicular to the displacement along the equipotential surface. This result shows that the equipotential surfaces must always be perpendicular to the electric field lines passing through them.

As mentioned at the end of Section 25.2, the equipotential surfaces associated with a uniform electric field consist of a family of planes perpendicular to the field lines. Figure 25.11a shows some representative equipotential surfaces for this situation.

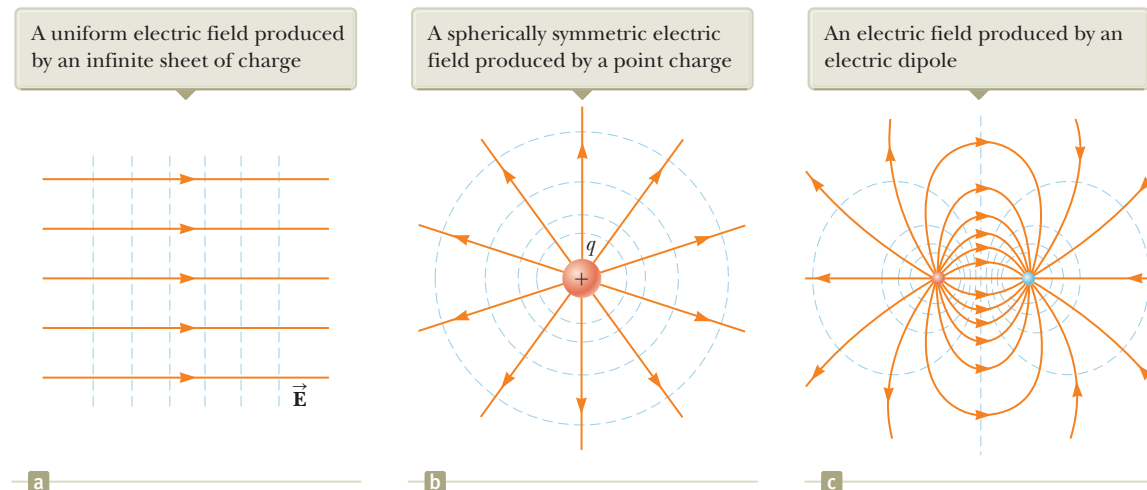

Figure 25.11 Equipotential surfaces (the dashed blue lines are intersections of these surfaces with the page) and electric field lines. In all cases, the equipotential surfaces are *perpendicular* to the electric field lines at every point.

If the charge distribution creating an electric field has spherical symmetry such that the volume charge density depends only on the radial distance r , the electric field is radial. In this case, $\vec{\mathbf{E}} \cdot d\vec{\mathbf{s}} = E_r dr$, and we can express dV as $dV = -E_r dr$. Therefore,

$$E_r = -\frac{dV}{dr} \quad (25.17)$$

For example, the electric potential of a point charge is $V = k_e q/r$. Because V is a function of r only, the potential function has spherical symmetry. Applying Equation 25.17, we find that the magnitude of the electric field due to the point charge is $E_r = k_e q/r^2$, a familiar result. Notice that the potential changes only in the radial direction, not in any direction perpendicular to r . Therefore, V (like E_r) is a function only of r , which is again consistent with the idea that equipotential surfaces are perpendicular to field lines. In this case, the equipotential surfaces are a family of spheres concentric with the spherically symmetric charge distribution (Fig. 25.11b). The equipotential surfaces for an electric dipole are sketched in Figure 25.11c.

In general, the electric potential is a function of all three spatial coordinates. If $V(r)$ is given in terms of the Cartesian coordinates, the electric field components E_x , E_y , and E_z can readily be found from $V(x, y, z)$ as the partial derivatives²

$$E_x = -\frac{\partial V}{\partial x} \quad E_y = -\frac{\partial V}{\partial y} \quad E_z = -\frac{\partial V}{\partial z} \quad (25.18)$$

Finding the electric field from the potential

Quick Quiz 25.4 In a certain region of space, the electric potential is zero everywhere along the x axis. (i) From this information, you can conclude that the x component of the electric field in this region is (a) zero, (b) in the positive x direction, or (c) in the negative x direction. (ii) Suppose the electric potential is $+2$ V everywhere along the x axis. From the same choices, what can you conclude about the x component of the electric field now?

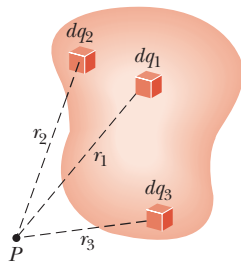

Figure 25.12 The electric potential at point P due to a continuous charge distribution can be calculated by dividing the charge distribution into elements of charge dq and summing the electric potential contributions over all elements. Three sample elements of charge are shown.

Electric potential due to a continuous charge distribution

25.5 Electric Potential Due to Continuous Charge Distributions

In Section 25.3, we found how to determine the electric potential due to a small number of charges. What if we wish to find the potential due to a continuous distribution of charge? The electric potential in this situation can be calculated using two different methods. The first method is as follows. If the charge distribution is known, we consider the potential due to a small charge element dq , treating this element as a point charge (Fig. 25.12). From Equation 25.11, the electric potential dV at some point P due to the charge element dq is

$$dV = k_e \frac{dq}{r} \quad (25.19)$$

where r is the distance from the charge element to point P . To obtain the total potential at point P , we integrate Equation 25.19 to include contributions from all elements of the charge distribution. Because each element is, in general, a different distance from point P and k_e is constant, we can express V as

$$V = k_e \int \frac{dq}{r} \quad (25.20)$$

²In vector notation, $\vec{\mathbf{E}}$ is often written in Cartesian coordinate systems as

$$\vec{\mathbf{E}} = -\nabla V = -\left(\hat{\mathbf{i}} \frac{\partial}{\partial x} + \hat{\mathbf{j}} \frac{\partial}{\partial y} + \hat{\mathbf{k}} \frac{\partial}{\partial z}\right)V$$

where ∇ is called the *gradient operator*.

In effect, we have replaced the sum in Equation 25.12 with an integral. In this expression for V , the electric potential is taken to be zero when point P is infinitely far from the charge distribution.

The second method for calculating the electric potential is used if the electric field is already known from other considerations such as Gauss's law. If the charge distribution has sufficient symmetry, we first evaluate \vec{E} using Gauss's law and then substitute the value obtained into Equation 25.3 to determine the potential difference ΔV between any two points. We then choose the electric potential V to be zero at some convenient point.

Problem-Solving Strategy Calculating Electric Potential

The following procedure is recommended for solving problems that involve the determination of an electric potential due to a charge distribution.

1. Conceptualize. Think carefully about the individual charges or the charge distribution you have in the problem and imagine what type of potential would be created. Appeal to any symmetry in the arrangement of charges to help you visualize the potential.

2. Categorize. Are you analyzing a group of individual charges or a continuous charge distribution? The answer to this question will tell you how to proceed in the *Analyze* step.

3. Analyze. When working problems involving electric potential, remember that it is a *scalar quantity*, so there are no components to consider. Therefore, when using the superposition principle to evaluate the electric potential at a point, simply take the algebraic sum of the potentials due to each charge. You must keep track of signs, however.

As with potential energy in mechanics, only *changes* in electric potential are significant; hence, the point where the potential is set at zero is arbitrary. When dealing with point charges or a finite-sized charge distribution, we usually define $V = 0$ to be at a point infinitely far from the charges. If the charge distribution itself extends to infinity, however, some other nearby point must be selected as the reference point.

(a) If you are analyzing a group of individual charges: Use the superposition principle, which states that when several point charges are present, the resultant potential at a point P in space is the *algebraic sum* of the individual potentials at P due to the individual charges (Eq. 25.12). Example 25.4 below demonstrates this procedure.

(b) If you are analyzing a continuous charge distribution: Replace the sums for evaluating the total potential at some point P from individual charges by integrals (Eq. 25.20). The total potential at P is obtained by integrating over the entire charge distribution. For many problems, it is possible in performing the integration to express dq and r in terms of a single variable. To simplify the integration, give careful consideration to the geometry involved in the problem. Examples 25.5 through 25.7 demonstrate such a procedure.

To obtain the potential from the electric field: Another method used to obtain the potential is to start with the definition of the potential difference given by Equation 25.3. If \vec{E} is known or can be obtained easily (such as from Gauss's law), the line integral of $\vec{E} \cdot d\vec{s}$ can be evaluated.

4. Finalize. Check to see if your expression for the potential is consistent with your mental representation and reflects any symmetry you noted previously. Imagine varying parameters such as the distance of the observation point from the charges or the radius of any circular objects to see if the mathematical result changes in a reasonable way.

Example 25.4 The Electric Potential Due to a Dipole

An electric dipole consists of two charges of equal magnitude and opposite sign separated by a distance $2a$ as shown in Figure 25.13. The dipole is along the x axis and is centered at the origin.

(A) Calculate the electric potential at point P on the y axis.

SOLUTION

Conceptualize Compare this situation to that in part (B) of Example 23.6. It is the same situation, but here we are seeking the electric potential rather than the electric field.

Categorize We categorize the problem as one in which we have a small number of particles rather than a continuous distribution of charge. The electric potential can be evaluated by summing the potentials due to the individual charges.

Analyze Use Equation 25.12 to find the electric potential at P due to the two charges:

$$V_P = k_e \sum_i \frac{q_i}{r_i} = k_e \left(\frac{q}{\sqrt{a^2 + y^2}} + \frac{-q}{\sqrt{a^2 + y^2}} \right) = 0$$

(B) Calculate the electric potential at point R on the positive x axis.

SOLUTION

Use Equation 25.12 to find the electric potential at R due to the two charges:

$$V_R = k_e \sum_i \frac{q_i}{r_i} = k_e \left(\frac{-q}{x-a} + \frac{q}{x+a} \right) = -\frac{2k_e qa}{x^2 - a^2}$$

(C) Calculate V and E_x at a point on the x axis far from the dipole.

SOLUTION

For point R far from the dipole such that $x \gg a$, neglect a^2 in the denominator of the answer to part (B) and write V in this limit:

$$V_R = \lim_{x \gg a} \left(-\frac{2k_e qa}{x^2 - a^2} \right) \approx -\frac{2k_e qa}{x^2} \quad (x \gg a)$$

Use Equation 25.16 and this result to calculate the x component of the electric field at a point on the x axis far from the dipole:

$$\begin{aligned} E_x &= -\frac{dV}{dx} = -\frac{d}{dx} \left(-\frac{2k_e qa}{x^2} \right) \\ &= 2k_e qa \frac{d}{dx} \left(\frac{1}{x^2} \right) = -\frac{4k_e qa}{x^3} \quad (x \gg a) \end{aligned}$$

Finalize The potentials in parts (B) and (C) are negative because points on the positive x axis are closer to the negative charge than to the positive charge. For the same reason, the x component of the electric field is negative. Notice that we have a $1/r^3$ falloff of the electric field with distance far from the dipole, similar to the behavior of the electric field on the y axis in Example 23.6.

WHAT IF? Suppose you want to find the electric field at a point P on the y axis. In part (A), the electric potential was found to be zero for all values of y . Is the electric field zero at all points on the y axis?

Answer No. That there is no change in the potential along the y axis tells us only that the y component of the electric field is zero. Look back at Figure 23.13 in Example 23.6. We showed there that the electric field of a dipole on the y axis has only an x component. We could not find the x component in the current example because we do not have an expression for the potential near the y axis as a function of x .

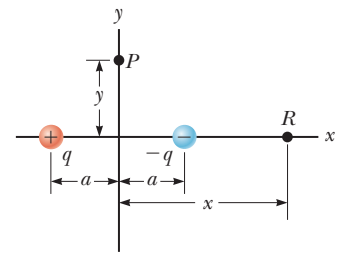

Figure 25.13 (Example 25.4) An electric dipole located on the x axis.

Example 25.5 Electric Potential Due to a Uniformly Charged Ring

(A) Find an expression for the electric potential at a point P located on the perpendicular central axis of a uniformly charged ring of radius a and total charge Q .

SOLUTION

Conceptualize Study Figure 25.14, in which the ring is oriented so that its plane is perpendicular to the x axis and its center is at the origin. Notice that the symmetry of the situation means that all the charges on the ring are the same distance from point P . Compare this example to Example 23.8. Notice that no vector considerations are necessary here because electric potential is a scalar.

Categorize Because the ring consists of a continuous distribution of charge rather than a set of discrete charges, we must use the integration technique represented by Equation 25.20 in this example.

Analyze We take point P to be at a distance x from the center of the ring as shown in Figure 25.14.

Use Equation 25.20 to express V in terms of the geometry:

$$V = k_e \int \frac{dq}{r} = k_e \int \frac{dq}{\sqrt{a^2 + x^2}}$$

Noting that a and x do not vary for an integration over the ring, bring $\sqrt{a^2 + x^2}$ in front of the integral sign and integrate over the ring:

$$V = \frac{k_e}{\sqrt{a^2 + x^2}} \int dq = \frac{k_e Q}{\sqrt{a^2 + x^2}} \quad (25.21)$$

(B) Find an expression for the magnitude of the electric field at point P .

SOLUTION

From symmetry, notice that along the x axis \vec{E} can have only an x component. Therefore, apply Equation 25.16 to Equation 25.21:

$$\begin{aligned} E_x &= -\frac{dV}{dx} = -k_e Q \frac{d}{dx} (a^2 + x^2)^{-1/2} \\ &= -k_e Q \left(-\frac{1}{2}\right) (a^2 + x^2)^{-3/2} (2x) \end{aligned}$$

$$E_x = \frac{k_e x}{(a^2 + x^2)^{3/2}} Q \quad (25.22)$$

Finalize The only variable in the expressions for V and E_x is x . That is not surprising because our calculation is valid only for points along the x axis, where y and z are both zero. This result for the electric field agrees with that obtained by direct integration (see Example 23.8). For practice, use the result of part (B) in Equation 25.3 to verify that the potential is given by the expression in part (A).

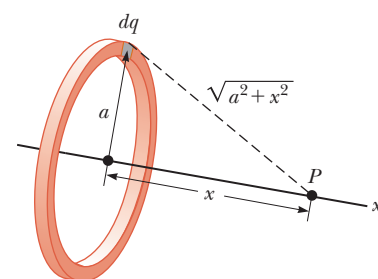

Figure 25.14 (Example 25.5) A uniformly charged ring of radius a lies in a plane perpendicular to the x axis. All elements dq of the ring are the same distance from a point P lying on the x axis.

Example 25.6 Electric Potential Due to a Uniformly Charged Disk

A uniformly charged disk has radius R and surface charge density σ .

(A) Find the electric potential at a point P along the perpendicular central axis of the disk.

SOLUTION

Conceptualize If we consider the disk to be a set of concentric rings, we can use our result from Example 25.5—which gives the potential due to a ring of radius a —and sum the contributions of all rings making up the disk. Figure

continued

25.6 continued

25.15 shows one such ring. Because point P is on the central axis of the disk, symmetry again tells us that all points in a given ring are the same distance from P .

Categorize Because the disk is continuous, we evaluate the potential due to a continuous charge distribution rather than a group of individual charges.

Analyze Find the amount of charge dq on a ring of radius r and width dr as shown in Figure 25.15:

Use this result in Equation 25.21 in Example 25.5 (with a replaced by the variable r and Q replaced by the differential dq) to find the potential due to the ring:

To obtain the total potential at P , integrate this expression over the limits $r = 0$ to $r = R$, noting that x is a constant:

This integral is of the common form $\int u^n du$, where $n = -\frac{1}{2}$ and $u = r^2 + x^2$, and has the value $u^{n+1}/(n+1)$. Use this result to evaluate the integral:

Figure 25.15 (Example 25.6) A uniformly charged disk of radius R lies in a plane perpendicular to the x axis. The calculation of the electric potential at any point P on the x axis is simplified by dividing the disk into many rings of radius r and width dr , with area $2\pi r dr$.

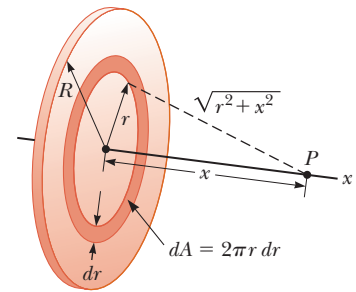

$$dq = \sigma dA = \sigma(2\pi r dr) = 2\pi\sigma r dr$$

$$dV = \frac{k_e dq}{\sqrt{r^2 + x^2}} = \frac{k_e 2\pi\sigma r dr}{\sqrt{r^2 + x^2}}$$

$$V = \pi k_e \sigma \int_0^R \frac{2r dr}{\sqrt{r^2 + x^2}} = \pi k_e \sigma \int_0^R (r^2 + x^2)^{-1/2} 2r dr$$

$$V = 2\pi k_e \sigma [(R^2 + x^2)^{1/2} - x] \quad (25.23)$$

(B) Find the x component of the electric field at a point P along the perpendicular central axis of the disk.

SOLUTION

As in Example 25.5, use Equation 25.16 to find the electric field at any axial point:

$$E_x = -\frac{dV}{dx} = 2\pi k_e \sigma \left[1 - \frac{x}{(R^2 + x^2)^{1/2}} \right] \quad (25.24)$$

Finalize Compare Equation 25.24 with the result of Example 23.9. They are the same. The calculation of V and \vec{E} for an arbitrary point off the x axis is more difficult to perform because of the absence of symmetry and we do not treat that situation in this book.

Example 25.7 Electric Potential Due to a Finite Line of Charge

A rod of length ℓ located along the x axis has a total charge Q and a uniform linear charge density λ . Find the electric potential at a point P located on the y axis a distance a from the origin (Fig. 25.16).

SOLUTION

Conceptualize The potential at P due to every segment of charge on the rod is positive because every segment carries a positive charge. Notice that we have no symmetry to appeal to here, but the simple geometry should make the problem solvable.

Categorize Because the rod is continuous, we evaluate the potential due to a continuous charge distribution rather than a group of individual charges.

Analyze In Figure 25.16, the rod lies along the x axis, dx is the length of one small segment, and dq is the charge on that segment. Because the rod has a charge per unit length λ , the charge dq on the small segment is $dq = \lambda dx$.

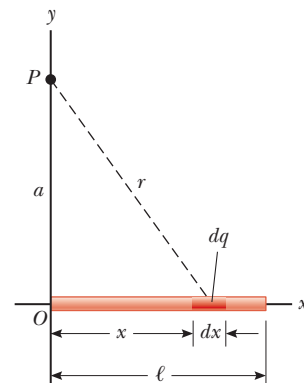

Figure 25.16 (Example 25.7) A uniform line charge of length ℓ located along the x axis. To calculate the electric potential at P , the line charge is divided into segments each of length dx and each carrying a charge $dq = \lambda dx$.

25.7 continued

Find the potential at P due to one segment of the rod at an arbitrary position x :

$$dV = k_e \frac{dq}{r} = k_e \frac{\lambda dx}{\sqrt{a^2 + x^2}}$$

Find the total potential at P by integrating this expression over the limits $x = 0$ to $x = \ell$:

$$V = \int_0^\ell k_e \frac{\lambda dx}{\sqrt{a^2 + x^2}}$$

Noting that k_e and $\lambda = Q/\ell$ are constants and can be removed from the integral, evaluate the integral with the help of Appendix B:

$$V = k_e \lambda \int_0^\ell \frac{dx}{\sqrt{a^2 + x^2}} = k_e \frac{Q}{\ell} \ln(x + \sqrt{a^2 + x^2}) \Big|_0^\ell$$

Evaluate the result between the limits: $V = k_e \frac{Q}{\ell} [\ln(\ell + \sqrt{a^2 + \ell^2}) - \ln a] = k_e \frac{Q}{\ell} \ln\left(\frac{\ell + \sqrt{a^2 + \ell^2}}{a}\right)$ (25.25)

Finalize If $\ell \ll a$, the potential at P should approach that of a point charge because the rod is very short compared to the distance from the rod to P . By using a series expansion for the natural logarithm from Appendix B.5, it is easy to show that Equation 25.25 becomes $V = k_e Q/a$.

WHAT IF? What if you were asked to find the electric field at point P ? Would that be a simple calculation?

Answer Calculating the electric field by means of Equation 23.11 would be a little messy. There is no symmetry to appeal to, and the integration over the line of charge would represent a vector addition of electric fields at point P . Using Equation 25.18, you could find E_y by replacing a with y in Equation 25.25 and performing the differentiation with respect to y . Because the charged rod in Figure

25.16 lies entirely to the right of $x = 0$, the electric field at point P would have an x component to the left if the rod is charged positively. You cannot use Equation 25.18 to find the x component of the field, however, because the potential due to the rod was evaluated at a specific value of x ($x = 0$) rather than a general value of x . You would have to find the potential as a function of both x and y to be able to find the x and y components of the electric field using Equation 25.18.

25.6 Electric Potential Due to a Charged Conductor

In Section 24.4, we found that when a solid conductor in equilibrium carries a net charge, the charge resides on the conductor's outer surface. Furthermore, the electric field just outside the conductor is perpendicular to the surface and the field inside is zero.

We now generate another property of a charged conductor, related to electric potential. Consider two points **A** and **B** on the surface of a charged conductor as shown in Figure 25.17. Along a surface path connecting these points, \vec{E} is always

Notice from the spacing of the positive signs that the surface charge density is nonuniform.

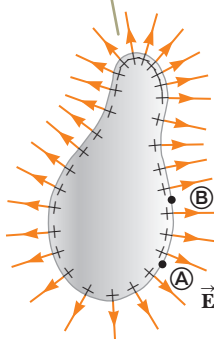

Figure 25.17 An arbitrarily shaped conductor carrying a positive charge. When the conductor is in electrostatic equilibrium, all the charge resides at the surface, $\vec{E} = 0$ inside the conductor, and the direction of \vec{E} immediately outside the conductor is perpendicular to the surface. The electric potential is constant inside the conductor and is equal to the potential at the surface.

Pitfall Prevention 25.6

Potential May Not Be Zero

The electric potential inside the conductor is not necessarily zero in Figure 25.17, even though the electric field is zero. Equation 25.15 shows that a zero value of the field results in no change in the potential from one point to another inside the conductor. Therefore, the potential everywhere inside the conductor, including the surface, has the same value, which may or may not be zero, depending on where the zero of potential is defined.

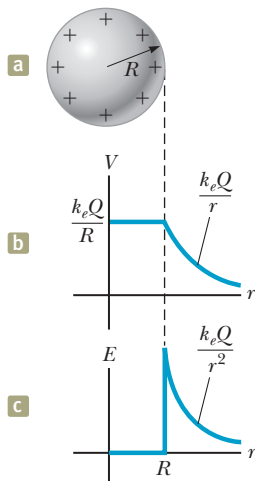

Figure 25.18 (a) The excess charge on a conducting sphere of radius R is uniformly distributed on its surface. (b) Electric potential versus distance r from the center of the charged conducting sphere. (c) Electric field magnitude versus distance r from the center of the charged conducting sphere.

perpendicular to the displacement $d\vec{s}$; therefore, $\vec{E} \cdot d\vec{s} = 0$. Using this result and Equation 25.3, we conclude that the potential difference between \textcircled{A} and \textcircled{B} is necessarily zero:

$$V_{\textcircled{B}} - V_{\textcircled{A}} = - \int_{\textcircled{A}}^{\textcircled{B}} \vec{E} \cdot d\vec{s} = 0$$

This result applies to any two points on the surface. Therefore, V is constant everywhere on the surface of a charged conductor in equilibrium. That is,

the surface of any charged conductor in electrostatic equilibrium is an equipotential surface: every point on the surface of a charged conductor in equilibrium is at the same electric potential. Furthermore, because the electric field is zero inside the conductor, the electric potential is constant everywhere inside the conductor and equal to its value at the surface.

Because of the constant value of the potential, no work is required to move a charge from the interior of a charged conductor to its surface.

Consider a solid metal conducting sphere of radius R and total positive charge Q as shown in Figure 25.18a. As determined in part (A) of Example 24.3, the electric field outside the sphere is $k_e Q/r^2$ and points radially outward. Because the field outside a spherically symmetric charge distribution is identical to that of a point charge, we expect the potential to also be that of a point charge, $k_e Q/r$. At the surface of the conducting sphere in Figure 25.18a, the potential must be $k_e Q/R$. Because the entire sphere must be at the same potential, the potential at any point within the sphere must also be $k_e Q/R$. Figure 25.18b is a plot of the electric potential as a function of r , and Figure 25.18c shows how the electric field varies with r .

When a net charge is placed on a spherical conductor, the surface charge density is uniform as indicated in Figure 25.18a. If the conductor is nonspherical as in Figure 25.17, however, the surface charge density is high where the radius of curvature is small (as noted in Section 24.4) and low where the radius of curvature is large. Because the electric field immediately outside the conductor is proportional to the surface charge density, the electric field is large near convex points having small radii of curvature and reaches very high values at sharp points. In Example 25.8, the relationship between electric field and radius of curvature is explored mathematically.

Example 25.8 Two Connected Charged Spheres

Two spherical conductors of radii r_1 and r_2 are separated by a distance much greater than the radius of either sphere. The spheres are connected by a conducting wire as shown in Figure 25.19. The charges on the spheres in equilibrium are q_1 and q_2 , respectively, and they are uniformly charged. Find the ratio of the magnitudes of the electric fields at the surfaces of the spheres.

SOLUTION

Conceptualize Imagine the spheres are much farther apart than shown in Figure 25.19. Because they are so far apart, the field of one does not affect the charge distribution on the other. The conducting wire between them ensures that both spheres have the same electric potential.

Categorize Because the spheres are so far apart, we model the charge distribution on them as spherically symmetric, and we can model the field and potential outside the spheres to be that due to point charges.

Analyze Set the electric potentials at the surfaces of the spheres equal to each other:

$$V = k_e \frac{q_1}{r_1} = k_e \frac{q_2}{r_2}$$

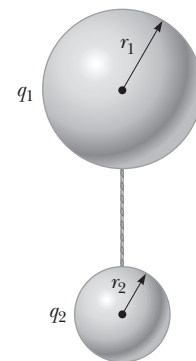

Figure 25.19 (Example 25.8) Two charged spherical conductors connected by a conducting wire. The spheres are at the same electric potential V .

► 25.8 continued

Solve for the ratio of charges on the spheres:

$$(1) \quad \frac{q_1}{q_2} = \frac{r_1}{r_2}$$

Write expressions for the magnitudes of the electric fields at the surfaces of the spheres:

$$E_1 = k_e \frac{q_1}{r_1^2} \quad \text{and} \quad E_2 = k_e \frac{q_2}{r_2^2}$$

Evaluate the ratio of these two fields:

$$\frac{E_1}{E_2} = \frac{q_1}{q_2} \frac{r_2^2}{r_1^2}$$

Substitute for the ratio of charges from Equation (1):

$$(2) \quad \frac{E_1}{E_2} = \frac{r_1}{r_2} \frac{r_2^2}{r_1^2} = \frac{r_2}{r_1}$$

Finalize The field is stronger in the vicinity of the smaller sphere even though the electric potentials at the surfaces of both spheres are the same. If $r_2 \rightarrow 0$, then $E_2 \rightarrow \infty$, verifying the statement above that the electric field is very large at sharp points.

A Cavity Within a Conductor

Suppose a conductor of arbitrary shape contains a cavity as shown in Figure 25.20. Let's assume no charges are inside the cavity. In this case, the electric field inside the cavity must be *zero* regardless of the charge distribution on the outside surface of the conductor as we mentioned in Section 24.4. Furthermore, the field in the cavity is zero even if an electric field exists outside the conductor.

To prove this point, remember that every point on the conductor is at the same electric potential; therefore, any two points \textcircled{A} and \textcircled{B} on the cavity's surface must be at the same potential. Now imagine a field \vec{E} exists in the cavity and evaluate the potential difference $V_{\textcircled{B}} - V_{\textcircled{A}}$ defined by Equation 25.3:

$$V_{\textcircled{B}} - V_{\textcircled{A}} = - \int_{\textcircled{A}}^{\textcircled{B}} \vec{E} \cdot d\vec{s}$$

Because $V_{\textcircled{B}} - V_{\textcircled{A}} = 0$, the integral of $\vec{E} \cdot d\vec{s}$ must be zero for all paths between any two points \textcircled{A} and \textcircled{B} on the conductor. The only way that can be true for *all* paths is if \vec{E} is zero *everywhere* in the cavity. Therefore, a cavity surrounded by conducting walls is a field-free region as long as no charges are inside the cavity.

Corona Discharge

A phenomenon known as **corona discharge** is often observed near a conductor such as a high-voltage power line. When the electric field in the vicinity of the conductor is sufficiently strong, electrons resulting from random ionizations of air molecules near the conductor accelerate away from their parent molecules. These rapidly moving electrons can ionize additional molecules near the conductor, creating more free electrons. The observed glow (or corona discharge) results from the recombination of these free electrons with the ionized air molecules. If a conductor has an irregular shape, the electric field can be very high near sharp points or edges of the conductor; consequently, the ionization process and corona discharge are most likely to occur around such points.

Corona discharge is used in the electrical transmission industry to locate broken or faulty components. For example, a broken insulator on a transmission tower has sharp edges where corona discharge is likely to occur. Similarly, corona discharge will occur at the sharp end of a broken conductor strand. Observation of these discharges is difficult because the visible radiation emitted is weak and most of the radiation is in the ultraviolet. (We will discuss ultraviolet radiation and other portions of the electromagnetic spectrum in Section 34.7.) Even use of traditional ultraviolet cameras is of little help because the radiation from the corona

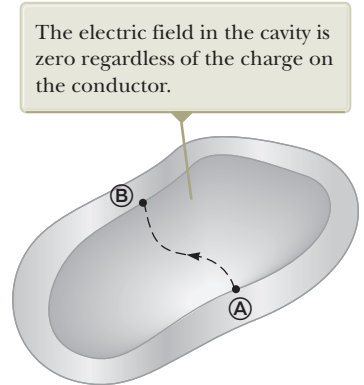
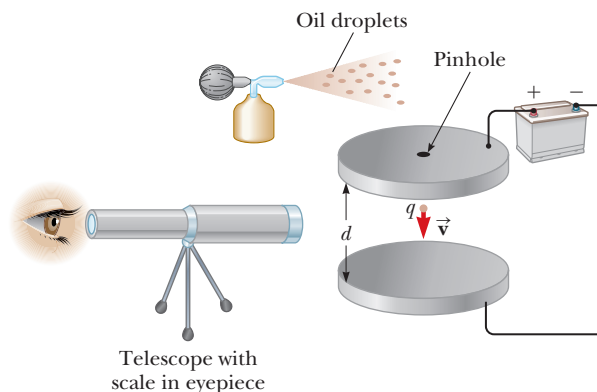

Figure 25.20 A conductor in electrostatic equilibrium containing a cavity.

Figure 25.21 Schematic drawing of the Millikan oil-drop apparatus.



discharge is overwhelmed by ultraviolet radiation from the Sun. Newly developed dual-spectrum devices combine a narrow-band ultraviolet camera with a visible-light camera to show a daylight view of the corona discharge in the actual location on the transmission tower or cable. The ultraviolet part of the camera is designed to operate in a wavelength range in which radiation from the Sun is very weak.

25.7 The Millikan Oil-Drop Experiment

With the electric field off, the droplet falls at terminal velocity \vec{v}_T under the influence of the gravitational and drag forces.

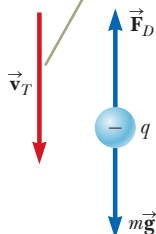

a

When the electric field is turned on, the droplet moves upward at terminal velocity \vec{v}'_T under the influence of the electric, gravitational, and drag forces.

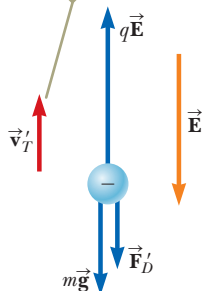

b

Robert Millikan performed a brilliant set of experiments from 1909 to 1913 in which he measured e , the magnitude of the elementary charge on an electron, and demonstrated the quantized nature of this charge. His apparatus, diagrammed in Figure 25.21, contains two parallel metallic plates. Oil droplets from an atomizer are allowed to pass through a small hole in the upper plate. Millikan used x-rays to ionize the air in the chamber so that freed electrons would adhere to the oil drops, giving them a negative charge. A horizontally directed light beam is used to illuminate the oil droplets, which are viewed through a telescope whose long axis is perpendicular to the light beam. When viewed in this manner, the droplets appear as shining stars against a dark background and the rate at which individual drops fall can be determined.

Let's assume a single drop having a mass m and carrying a charge q is being viewed and its charge is negative. If no electric field is present between the plates, the two forces acting on the charge are the gravitational force $m\vec{g}$ acting downward³ and a viscous drag force \vec{F}_D acting upward as indicated in Figure 25.22a. The drag force is proportional to the drop's speed as discussed in Section 6.4. When the drop reaches its terminal speed v_T the two forces balance each other ($mg = F_D$).

Now suppose a battery connected to the plates sets up an electric field between the plates such that the upper plate is at the higher electric potential. In this case, a third force $q\vec{E}$ acts on the charged drop. The particle in a field model applies twice to the particle: it is in a gravitational field and an electric field. Because q is negative and \vec{E} is directed downward, this electric force is directed upward as shown in Figure 25.22b. If this upward force is strong enough, the drop moves upward and the drag force \vec{F}'_D acts downward. When the upward electric force $q\vec{E}$ balances the sum of the gravitational force and the downward drag force \vec{F}'_D , the drop reaches a new terminal speed v'_T in the upward direction.

With the field turned on, a drop moves slowly upward, typically at rates of hundredths of a centimeter per second. The rate of fall in the absence of a field is comparable. Hence, one can follow a single droplet for hours, alternately rising and falling, by simply turning the electric field on and off.

Figure 25.22 The forces acting on a negatively charged oil droplet in the Millikan experiment.

³There is also a buoyant force on the oil drop due to the surrounding air. This force can be incorporated as a correction in the gravitational force $m\vec{g}$ on the drop, so we will not consider it in our analysis.

After recording measurements on thousands of droplets, Millikan and his coworkers found that all droplets, to within about 1% precision, had a charge equal to some integer multiple of the elementary charge e :

$$q = ne \quad n = 0, -1, -2, -3, \dots$$

where $e = 1.60 \times 10^{-19}$ C. Millikan's experiment yields conclusive evidence that charge is quantized. For this work, he was awarded the Nobel Prize in Physics in 1923.

25.8 Applications of Electrostatics

The practical application of electrostatics is represented by such devices as lightning rods and electrostatic precipitators and by such processes as xerography and the painting of automobiles. Scientific devices based on the principles of electrostatics include electrostatic generators, the field-ion microscope, and ion-drive rocket engines. Details of two devices are given below.

The Van de Graaff Generator

Experimental results show that when a charged conductor is placed in contact with the inside of a hollow conductor, all the charge on the charged conductor is transferred to the hollow conductor. In principle, the charge on the hollow conductor and its electric potential can be increased without limit by repetition of the process.

In 1929, Robert J. Van de Graaff (1901–1967) used this principle to design and build an electrostatic generator, and a schematic representation of it is given in Figure 25.23. This type of generator was once used extensively in nuclear physics research. Charge is delivered continuously to a high-potential electrode by means of a moving belt of insulating material. The high-voltage electrode is a hollow metal dome mounted on an insulating column. The belt is charged at point A by means of a corona discharge between comb-like metallic needles and a grounded grid. The needles are maintained at a positive electric potential of typically 10^4 V. The positive charge on the moving belt is transferred to the dome by a second comb of needles at point B. Because the electric field inside the dome is negligible, the positive charge on the belt is easily transferred to the conductor regardless of its potential. In practice, it is possible to increase the electric potential of the dome until electrical discharge occurs through the air. Because the “breakdown” electric field in air is about 3×10^6 V/m, a sphere 1.00 m in radius can be raised to a maximum potential of 3×10^6 V. The potential can be increased further by increasing the dome's radius and placing the entire system in a container filled with high-pressure gas.

Van de Graaff generators can produce potential differences as large as 20 million volts. Protons accelerated through such large potential differences receive enough energy to initiate nuclear reactions between themselves and various target nuclei. Smaller generators are often seen in science classrooms and museums. If a person insulated from the ground touches the sphere of a Van de Graaff generator, his or her body can be brought to a high electric potential. The person's hair acquires a net positive charge, and each strand is repelled by all the others as in the opening photograph of Chapter 23.

The Electrostatic Precipitator

One important application of electrical discharge in gases is the *electrostatic precipitator*. This device removes particulate matter from combustion gases, thereby reducing air pollution. Precipitators are especially useful in coal-burning power plants and industrial operations that generate large quantities of smoke. Current systems are able to eliminate more than 99% of the ash from smoke.

Figure 25.24a (page 766) shows a schematic diagram of an electrostatic precipitator. A high potential difference (typically 40 to 100 kV) is maintained between

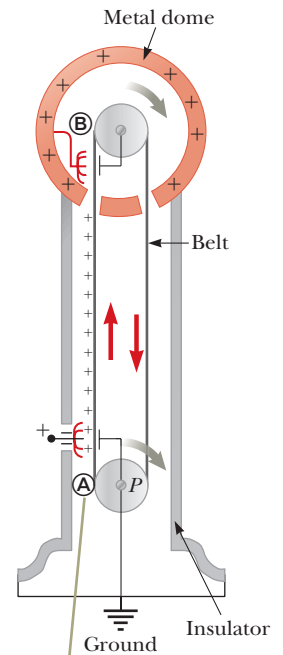

The charge is deposited on the belt at point A and transferred to the hollow conductor at point B.

Figure 25.23 Schematic diagram of a Van de Graaff generator. Charge is transferred to the metal dome at the top by means of a moving belt.

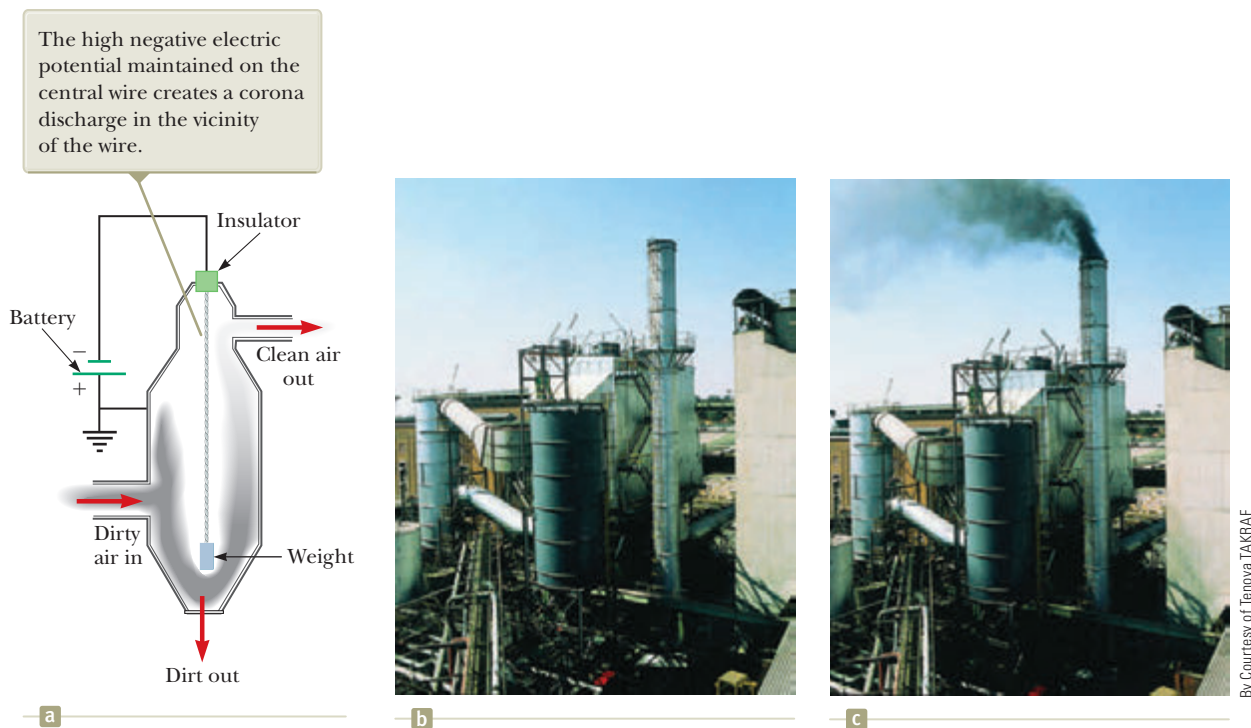

Figure 25.24 (a) Schematic diagram of an electrostatic precipitator. Compare the air pollution when the electrostatic precipitator is (b) operating and (c) turned off.

a wire running down the center of a duct and the walls of the duct, which are grounded. The wire is maintained at a negative electric potential with respect to the walls, so the electric field is directed toward the wire. The values of the field near the wire become high enough to cause a corona discharge around the wire; the air near the wire contains positive ions, electrons, and such negative ions as O_2^- . The air to be cleaned enters the duct and moves near the wire. As the electrons and negative ions created by the discharge are accelerated toward the outer wall by the electric field, the dirt particles in the air become charged by collisions and ion capture. Because most of the charged dirt particles are negative, they too are drawn to the duct walls by the electric field. When the duct is periodically shaken, the particles break loose and are collected at the bottom.

In addition to reducing the level of particulate matter in the atmosphere (compare Figs. 25.24b and c), the electrostatic precipitator recovers valuable materials in the form of metal oxides.

Summary

Definitions

The **potential difference** ΔV between points $\textcircled{\text{A}}$ and $\textcircled{\text{B}}$ in an electric field $\vec{\mathbf{E}}$ is defined as

$$\Delta V \equiv \frac{\Delta U}{q} = -\int_{\textcircled{\text{A}}}^{\textcircled{\text{B}}} \vec{\mathbf{E}} \cdot d\vec{\mathbf{s}} \quad (25.3)$$

where ΔU is given by Equation 25.1 on page 767. The **electric potential** $V = U/q$ is a scalar quantity and has the units of joules per coulomb, where $1 \text{ J/C} \equiv 1 \text{ V}$.

An **equipotential surface** is one on which all points are at the same electric potential. Equipotential surfaces are perpendicular to electric field lines.

Concepts and Principles

When a positive charge q is moved between points \textcircled{A} and \textcircled{B} in an electric field \vec{E} , the change in the potential energy of the charge-field system is

$$\Delta U = -q \int_{\textcircled{A}}^{\textcircled{B}} \vec{E} \cdot d\vec{s} \quad (25.1)$$

If we define $V = 0$ at $r = \infty$, the electric potential due to a point charge at any distance r from the charge is

$$V = k_e \frac{q}{r} \quad (25.11)$$

The electric potential associated with a group of point charges is obtained by summing the potentials due to the individual charges.

If the electric potential is known as a function of coordinates x , y , and z , we can obtain the components of the electric field by taking the negative derivative of the electric potential with respect to the coordinates. For example, the x component of the electric field is

$$E_x = -\frac{dV}{dx} \quad (25.16)$$

The potential difference between two points separated by a distance d in a uniform electric field \vec{E} is

$$\Delta V = -Ed \quad (25.6)$$

if the direction of travel between the points is in the same direction as the electric field.

The **electric potential energy** associated with a pair of point charges separated by a distance r_{12} is

$$U = k_e \frac{q_1 q_2}{r_{12}} \quad (25.13)$$

We obtain the potential energy of a distribution of point charges by summing terms like Equation 25.13 over all pairs of particles.

The electric potential due to a continuous charge distribution is

$$V = k_e \int \frac{dq}{r} \quad (25.20)$$

Every point on the surface of a charged conductor in electrostatic equilibrium is at the same electric potential. The potential is constant everywhere inside the conductor and equal to its value at the surface.

Objective Questions

1. denotes answer available in *Student Solutions Manual/Study Guide*

- In a certain region of space, the electric field is zero. From this fact, what can you conclude about the electric potential in this region? (a) It is zero. (b) It does not vary with position. (c) It is positive. (d) It is negative. (e) None of those answers is necessarily true.
- Consider the equipotential surfaces shown in Figure 25.4. In this region of space, what is the approximate direction of the electric field? (a) It is out of the page. (b) It is into the page. (c) It is toward the top of the page. (d) It is toward the bottom of the page. (e) The field is zero.
- (i) A metallic sphere A of radius 1.00 cm is several centimeters away from a metallic spherical shell B of radius 2.00 cm. Charge 450 nC is placed on A, with no charge on B or anywhere nearby. Next, the two objects are joined by a long, thin, metallic wire (as shown in Fig. 25.19), and finally the wire is removed. How is the charge shared between A and B? (a) 0 on A, 450 nC on B (b) 90.0 nC on A and 360 nC on B, with equal surface charge densities (c) 150 nC on A and 300 nC on B (d) 225 nC on A and 225 nC on B (e) 450 nC on A and 0 on B (ii) A metallic sphere A of radius 1 cm with charge 450 nC hangs on an insulating thread inside an uncharged thin metallic spherical shell B of radius 2 cm. Next, A is made temporarily to touch the inner surface of B. How is the charge then shared between

them? Choose from the same possibilities. Arnold Arons, the only physics teacher yet to have his picture on the cover of *Time* magazine, suggested the idea for this question.

- The electric potential at $x = 3.00$ m is 120 V, and the electric potential at $x = 5.00$ m is 190 V. What is the x component of the electric field in this region, assuming the field is uniform? (a) 140 N/C (b) -140 N/C (c) 35.0 N/C (d) -35.0 N/C (e) 75.0 N/C
- Rank the potential energies of the four systems of particles shown in Figure OQ25.5 from largest to smallest. Include equalities if appropriate.

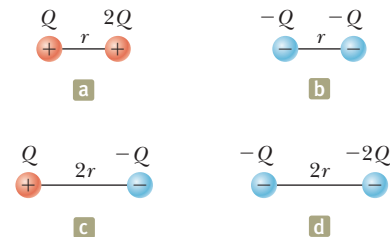

Figure OQ25.5

- In a certain region of space, a uniform electric field is in the x direction. A particle with negative charge is carried from $x = 20.0$ cm to $x = 60.0$ cm. (i) Does

the electric potential energy of the charge–field system (a) increase, (b) remain constant, (c) decrease, or (d) change unpredictably? (ii) Has the particle moved to a position where the electric potential is (a) higher than before, (b) unchanged, (c) lower than before, or (d) unpredictable?

7. Rank the electric potentials at the four points shown in Figure OQ25.7 from largest to smallest.

8. An electron in an x-ray machine is accelerated through a potential difference of 1.00×10^4 V before it hits the target. What is the kinetic energy of the electron in electron volts? (a) 1.00×10^4 eV (b) 1.60×10^{-15} eV (c) 1.60×10^{-22} eV (d) 6.25×10^{22} eV (e) 1.60×10^{-19} eV

9. Rank the electric potential energies of the systems of charges shown in Figure OQ25.9 from largest to smallest. Indicate equalities if appropriate.

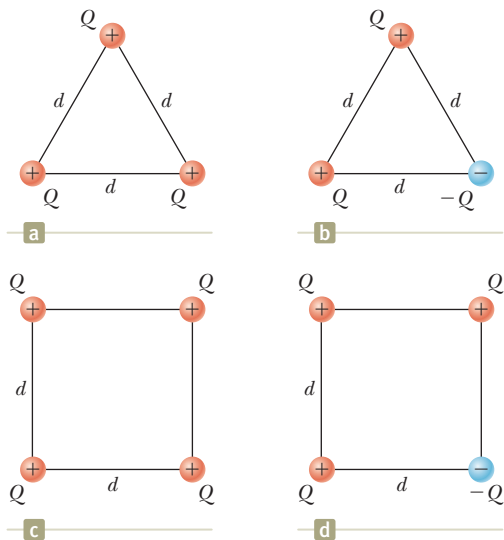

Figure OQ25.9

10. Four particles are positioned on the rim of a circle. The charges on the particles are $+0.500 \mu\text{C}$, $+1.50 \mu\text{C}$, $-1.00 \mu\text{C}$, and $-0.500 \mu\text{C}$. If the electric potential at the center of the circle due to the $+0.500 \mu\text{C}$ charge alone is 4.50×10^4 V, what is the total electric potential

at the center due to the four charges? (a) 18.0×10^4 V (b) 4.50×10^4 V (c) 0 (d) -4.50×10^4 V (e) 9.00×10^4 V

11. A proton is released from rest at the origin in a uniform electric field in the positive x direction with magnitude 850 N/C. What is the change in the electric potential energy of the proton–field system when the proton travels to $x = 2.50$ m? (a) 3.40×10^{-16} J (b) -3.40×10^{-16} J (c) 2.50×10^{-16} J (d) -2.50×10^{-16} J (e) -1.60×10^{-19} J

12. A particle with charge -40.0 nC is on the x axis at the point with coordinate $x = 0$. A second particle, with charge -20.0 nC, is on the x axis at $x = 0.500$ m. (i) Is the point at a finite distance where the electric field is zero (a) to the left of $x = 0$, (b) between $x = 0$ and $x = 0.500$ m, or (c) to the right of $x = 0.500$ m? (ii) Is the electric potential zero at this point? (a) No; it is positive. (b) Yes. (c) No; it is negative. (iii) Is there a point at a finite distance where the electric potential is zero? (a) Yes; it is to the left of $x = 0$. (b) Yes; it is between $x = 0$ and $x = 0.500$ m. (c) Yes; it is to the right of $x = 0.500$ m. (d) No.

13. A filament running along the x axis from the origin to $x = 80.0$ cm carries electric charge with uniform density. At the point P with coordinates ($x = 80.0$ cm, $y = 80.0$ cm), this filament creates electric potential 100 V. Now we add another filament along the y axis, running from the origin to $y = 80.0$ cm, carrying the same amount of charge with the same uniform density. At the same point P , is the electric potential created by the pair of filaments (a) greater than 200 V, (b) 200 V, (c) 100 V, (d) between 0 and 200 V, or (e) 0 ?

14. In different experimental trials, an electron, a proton, or a doubly charged oxygen atom (O^{2-}), is fired within a vacuum tube. The particle's trajectory carries it through a point where the electric potential is 40.0 V and then through a point at a different potential. Rank each of the following cases according to the change in kinetic energy of the particle over this part of its flight from the largest increase to the largest decrease in kinetic energy. In your ranking, display any cases of equality. (a) An electron moves from 40.0 V to 60.0 V. (b) An electron moves from 40.0 V to 20.0 V. (c) A proton moves from 40.0 V to 20.0 V. (d) A proton moves from 40.0 V to 10.0 V. (e) An O^{2-} ion moves from 40.0 V to 60.0 V.

15. A helium nucleus (charge $= 2e$, mass $= 6.63 \times 10^{-27}$ kg) traveling at 6.20×10^5 m/s enters an electric field, traveling from point A , at a potential of 1.50×10^3 V, to point B , at 4.00×10^3 V. What is its speed at point B ? (a) 7.91×10^5 m/s (b) 3.78×10^5 m/s (c) 2.13×10^5 m/s (d) 2.52×10^6 m/s (e) 3.01×10^8 m/s

Conceptual Questions

1. denotes answer available in *Student Solutions Manual/Study Guide*

1. What determines the maximum electric potential to which the dome of a Van de Graaff generator can be raised?
2. Describe the motion of a proton (a) after it is released from rest in a uniform electric field. Describe the

changes (if any) in (b) its kinetic energy and (c) the electric potential energy of the proton–field system.

3. When charged particles are separated by an infinite distance, the electric potential energy of the pair is zero. When the particles are brought close, the elec-

tric potential energy of a pair with the same sign is positive, whereas the electric potential energy of a pair with opposite signs is negative. Give a physical explanation of this statement.

4. Study Figure 23.3 and the accompanying text discussion of charging by induction. When the grounding wire is touched to the rightmost point on the sphere in Figure 23.3c, electrons are drained away from the sphere to leave the sphere positively charged. Suppose the

grounding wire is touched to the leftmost point on the sphere instead. (a) Will electrons still drain away, moving closer to the negatively charged rod as they do so? (b) What kind of charge, if any, remains on the sphere?

5. Distinguish between electric potential and electric potential energy.
6. Describe the equipotential surfaces for (a) an infinite line of charge and (b) a uniformly charged sphere.

Problems



The problems found in this chapter may be assigned online in Enhanced WebAssign

1. straightforward; 2. intermediate;
3. challenging

1. full solution available in the *Student Solutions Manual/Study Guide*

AMT Analysis Model tutorial available in Enhanced WebAssign

GP Guided Problem

M Master It tutorial available in Enhanced WebAssign

W Watch It video solution available in Enhanced WebAssign

Section 25.1 Electric Potential and Potential Difference

Section 25.2 Potential Difference in a Uniform Electric Field

1. Oppositely charged parallel plates are separated by 5.33 mm. A potential difference of 600 V exists between the plates. (a) What is the magnitude of the electric field between the plates? (b) What is the magnitude of the force on an electron between the plates? (c) How much work must be done on the electron to move it to the negative plate if it is initially positioned 2.90 mm from the positive plate?

2. A uniform electric field of magnitude 250 V/m is directed in the positive x direction. A $+12.0\text{-}\mu\text{C}$ charge moves from the origin to the point $(x, y) = (20.0\text{ cm}, 50.0\text{ cm})$. (a) What is the change in the potential energy of the charge–field system? (b) Through what potential difference does the charge move?

3. (a) Calculate the speed of a proton that is accelerated from rest through an electric potential difference of 120 V. (b) Calculate the speed of an electron that is accelerated through the same electric potential difference.

4. How much work is done (by a battery, generator, or some other source of potential difference) in moving Avogadro's number of electrons from an initial point where the electric potential is 9.00 V to a point where the electric potential is -5.00 V ? (The potential in each case is measured relative to a common reference point.)

5. A uniform electric field of magnitude 325 V/m is directed in the negative y direction in Figure P25.5. The coordinates of point

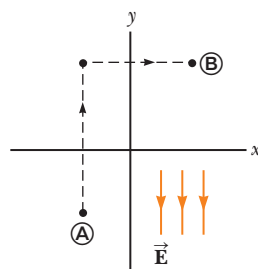

Figure P25.5

Ⓐ are $(-0.200, -0.300)\text{ m}$, and those of point Ⓑ are $(0.400, 0.500)\text{ m}$. Calculate the electric potential difference $V_{\text{B}} - V_{\text{A}}$ using the dashed-line path.

6. Starting with the definition of work, prove that at every point on an equipotential surface, the surface must be perpendicular to the electric field there.

7. An electron moving parallel to the x axis has an initial speed of $3.70 \times 10^6\text{ m/s}$ at the origin. Its speed is reduced to $1.40 \times 10^5\text{ m/s}$ at the point $x = 2.00\text{ cm}$. (a) Calculate the electric potential difference between the origin and that point. (b) Which point is at the higher potential?

8. (a) Find the electric potential difference ΔV_e required to stop an electron (called a “stopping potential”) moving with an initial speed of $2.85 \times 10^7\text{ m/s}$. (b) Would a proton traveling at the same speed require a greater or lesser magnitude of electric potential difference? Explain. (c) Find a symbolic expression for the ratio of the proton stopping potential and the electron stopping potential, $\Delta V_p / \Delta V_e$.

9. A particle having charge $q = +2.00\text{ }\mu\text{C}$ and mass $m = 0.0100\text{ kg}$ is connected to a string that is $L = 1.50\text{ m}$ long and tied to the pivot point P in Figure P25.9. The particle, string, and pivot point all lie on a frictionless,

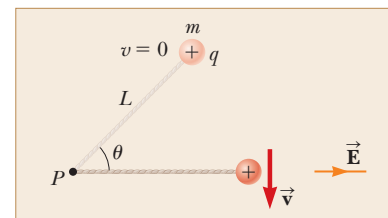

Figure P25.9

horizontal table. The particle is released from rest when the string makes an angle $\theta = 60.0^\circ$ with a uniform electric field of magnitude $E = 300 \text{ V/m}$. Determine the speed of the particle when the string is parallel to the electric field.

- 10. Review.** A block having mass m and charge $+Q$ is connected to an insulating spring having a force constant k . The block lies on a frictionless, insulating, horizontal track, and the system is immersed in a

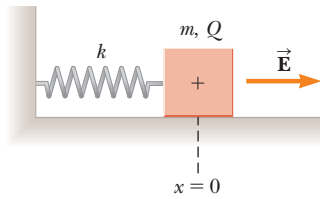

Figure P25.10

uniform electric field of magnitude E directed as shown in Figure P25.10. The block is released from rest when the spring is unstretched (at $x = 0$). We wish to show that the ensuing motion of the block is simple harmonic. (a) Consider the system of the block, the spring, and the electric field. Is this system isolated or nonisolated? (b) What kinds of potential energy exist within this system? (c) Call the initial configuration of the system that existing just as the block is released from rest. The final configuration is when the block momentarily comes to rest again. What is the value of x when the block comes to rest momentarily? (d) At some value of x we will call $x = x_0$, the block has zero net force on it. What analysis model describes the particle in this situation? (e) What is the value of x_0 ? (f) Define a new coordinate system x' such that $x' = x - x_0$. Show that x' satisfies a differential equation for simple harmonic motion. (g) Find the period of the simple harmonic motion. (h) How does the period depend on the electric field magnitude?

- 11.** An insulating rod having linear charge density $\lambda = 40.0 \mu\text{C/m}$ and linear mass density $\mu = 0.100 \text{ kg/m}$ is released from rest in a uniform electric field $E = 100 \text{ V/m}$ directed perpendicular to the rod (Fig. P25.11). (a) Determine the speed of the rod after it has traveled 2.00 m.

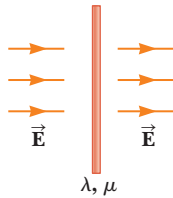

Figure P25.11

(b) **What If?** How does your answer to part (a) change if the electric field is not perpendicular to the rod? Explain.

Section 25.3 Electric Potential and Potential Energy Due to Point Charges

Note: Unless stated otherwise, assume the reference level of potential is $V = 0$ at $r = \infty$.

- 12.** (a) Calculate the electric potential 0.250 cm from an electron. (b) What is the electric potential difference between two points that are 0.250 cm and 0.750 cm from an electron? (c) How would the answers change if the electron were replaced with a proton?
- 13.** Two point charges are on the y axis. A $4.50\text{-}\mu\text{C}$ charge is located at $y = 1.25 \text{ cm}$, and a $-2.24\text{-}\mu\text{C}$ charge is located at $y = -1.80 \text{ cm}$. Find the total electric potential at (a) the origin and (b) the point whose coordinates are (1.50 cm, 0).

- 14.** The two charges in Figure P25.14 are separated by $d = 2.00 \text{ cm}$. Find the electric potential at (a) point A and (b) point B, which is halfway between the charges.

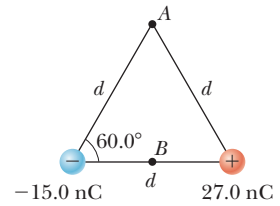

Figure P25.14

- 15.** Three positive charges are located at the corners of an equilateral triangle as in Figure P25.15. Find an expression for the electric potential at the center of the triangle.

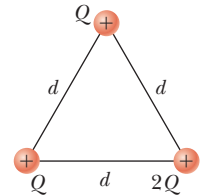

Figure P25.15

- 16.** Two point charges $Q_1 = +5.00 \text{ nC}$ and $Q_2 = -3.00 \text{ nC}$ are separated by 35.0 cm. (a) What is the electric potential at a point midway between the charges? (b) What is the potential energy of the pair of charges? What is the significance of the algebraic sign of your answer?

- 17.** Two particles, with charges of 20.0 nC and -20.0 nC , are placed at the points with coordinates (0, 4.00 cm) and (0, -4.00 cm) as shown in Figure P25.17. A particle with charge 10.0 nC is located at the origin.

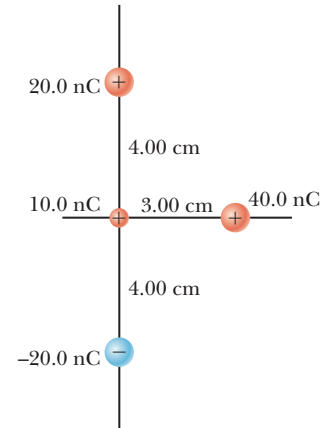

Figure P25.17

(a) Find the electric potential energy of the configuration of the three fixed charges. (b) A fourth particle, with a mass of $2.00 \times 10^{-13} \text{ kg}$ and a charge of 40.0 nC, is released from rest at the point (3.00 cm, 0). Find its speed after it has moved freely to a very large distance away.

- 18.** The two charges in Figure P25.18 are separated by a distance $d = 2.00 \text{ cm}$, and $Q = +5.00 \text{ nC}$. Find (a) the electric potential at A, (b) the electric potential at B, and (c) the electric potential difference between B and A.

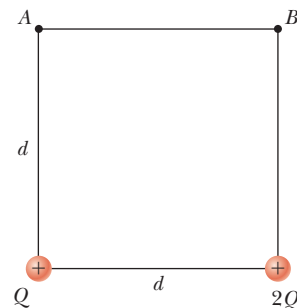

Figure P25.18

- 19.** Given two particles with $2.00\text{-}\mu\text{C}$ charges as shown in Figure P25.19 and a particle with charge $q = 1.28 \times 10^{-18} \text{ C}$ at the origin, (a) what is the net force exerted

by the two $2.00\text{-}\mu\text{C}$ charges on the charge q ? (b) What is the electric field at the origin due to the two $2.00\text{-}\mu\text{C}$ particles? (c) What is the electric potential at the origin due to the two $2.00\text{-}\mu\text{C}$ particles?

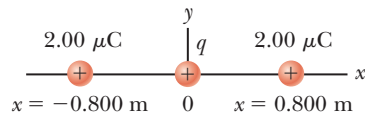

Figure P25.19

- 20.** At a certain distance from a charged particle, the magnitude of the electric field is 500 V/m and the electric potential is -3.00 kV . (a) What is the distance to the particle? (b) What is the magnitude of the charge?
- 21.** Four point charges each having charge Q are located at the corners of a square having sides of length a . Find expressions for (a) the total electric potential at the center of the square due to the four charges and (b) the work required to bring a fifth charge q from infinity to the center of the square.
- 22.** The three charged particles in Figure P25.22 are at the vertices of an isosceles triangle (where $d = 2.00\text{ cm}$). Taking $q = 7.00\text{ }\mu\text{C}$, calculate the electric potential at point A , the midpoint of the base.
- 23.** A particle with charge $+q$ is at the origin. A particle with charge $-2q$ is at $x = 2.00\text{ m}$ on the x axis. (a) For what finite value(s) of x is the electric field zero? (b) For what finite value(s) of x is the electric potential zero?



Figure P25.22

- 24.** Show that the amount of work required to assemble four identical charged particles of magnitude Q at the corners of a square of side s is $5.41k_eQ^2/s$.
- 25.** Two particles each with charge $+2.00\text{ }\mu\text{C}$ are located on the x axis. One is at $x = 1.00\text{ m}$, and the other is at $x = -1.00\text{ m}$. (a) Determine the electric potential on the y axis at $y = 0.500\text{ m}$. (b) Calculate the change in electric potential energy of the system as a third charged particle of $-3.00\text{ }\mu\text{C}$ is brought from infinitely far away to a position on the y axis at $y = 0.500\text{ m}$.
- 26.** Two charged particles of equal magnitude are located along the y axis equal distances above and below the x axis as shown in Figure P25.26. (a) Plot a graph of the electric potential at points along the x axis over the interval $-3a < x < 3a$. You should plot the potential in units of k_eQ/a . (b) Let the charge of the particle located at $y = -a$ be negative. Plot the potential along the y axis over the interval $-4a < y < 4a$.

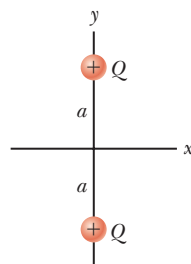

Figure P25.26

electric potential energy of the system as the particle at the lower left corner in Figure P25.27 is brought to this position from infinitely far away. Assume the other three particles in Figure P25.27 remain fixed in position.

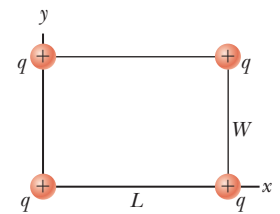

Figure P25.27

- 28.** Three particles with equal positive charges q are at the corners of an equilateral triangle of side a as shown in Figure P25.28. (a) At what point, if any, in the plane of the particles is the electric potential zero? (b) What is the electric potential at the position of one of the particles due to the other two particles in the triangle?
- 29.** Five particles with equal negative charges $-q$ are placed symmetrically around a circle of radius R . Calculate the electric potential at the center of the circle.
- 30. Review.** A light, unstressed spring has length d . Two identical particles, each with charge q , are connected to the opposite ends of the spring. The particles are held stationary a distance d apart and then released at the same moment. The system then oscillates on a frictionless, horizontal table. The spring has a bit of internal kinetic friction, so the oscillation is damped. The particles eventually stop vibrating when the distance between them is $3d$. Assume the system of the spring and two charged particles is isolated. Find the increase in internal energy that appears in the spring during the oscillations.
- 31. Review.** Two insulating spheres have radii 0.300 cm and 0.500 cm , masses 0.100 kg and 0.700 kg , and uniformly distributed charges $-2.00\text{ }\mu\text{C}$ and $3.00\text{ }\mu\text{C}$. They are released from rest when their centers are separated by 1.00 m . (a) How fast will each be moving when they collide? (b) **What If?** If the spheres were conductors, would the speeds be greater or less than those calculated in part (a)? Explain.
- 32. Review.** Two insulating spheres have radii r_1 and r_2 , masses m_1 and m_2 , and uniformly distributed charges $-q_1$ and q_2 . They are released from rest when their centers are separated by a distance d . (a) How fast is each moving when they collide? (b) **What If?** If the spheres were conductors, would their speeds be greater or less than those calculated in part (a)? Explain.
- 33.** How much work is required to assemble eight identical charged particles, each of magnitude q , at the corners of a cube of side s ?
- 34.** Four identical particles, each having charge q and mass m , are released from rest at the vertices of a square of side L . How fast is each particle moving when their distance from the center of the square doubles?
- 35.** In 1911, Ernest Rutherford and his assistants Geiger and Marsden conducted an experiment in which they

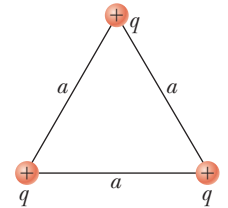

Figure P25.28

scattered alpha particles (nuclei of helium atoms) from thin sheets of gold. An alpha particle, having charge $+2e$ and mass 6.64×10^{-27} kg, is a product of certain radioactive decays. The results of the experiment led Rutherford to the idea that most of an atom's mass is in a very small nucleus, with electrons in orbit around it. (This is the planetary model of the atom, which we'll study in Chapter 42.) Assume an alpha particle, initially very far from a stationary gold nucleus, is fired with a velocity of 2.00×10^7 m/s directly toward the nucleus (charge $+79e$). What is the smallest distance between the alpha particle and the nucleus before the alpha particle reverses direction? Assume the gold nucleus remains stationary.

Section 25.4 Obtaining the Value of the Electric Field from the Electric Potential

36. Figure P25.36 represents a graph of the electric potential in a region of space versus position x , where the electric field is parallel to the x axis. Draw a graph of the x component of the electric field versus x in this region.

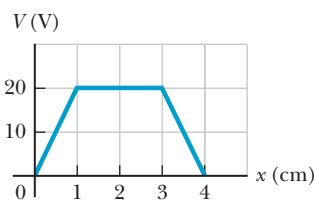

Figure P25.36

37. The potential in a region between $x = 0$ and $x = 6.00$ m is $V = a + bx$, where $a = 10.0$ V and $b = -7.00$ V/m. Determine (a) the potential at $x = 0, 3.00$ m, and 6.00 m and (b) the magnitude and direction of the electric field at $x = 0, 3.00$ m, and 6.00 m.
38. An electric field in a region of space is parallel to the x axis. The electric potential varies with position as shown in Figure P25.38. Graph the x component of the electric field versus position in this region of space.

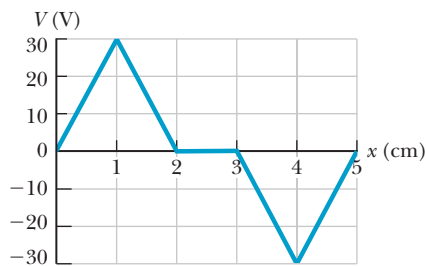
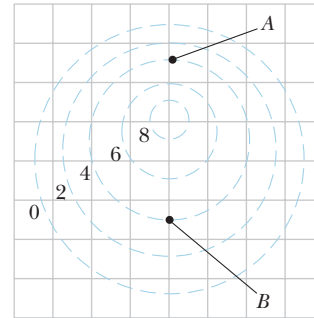

Figure P25.38

39. Over a certain region of space, the electric potential is $V = 5x - 3x^2y + 2yz^2$. (a) Find the expressions for the x , y , and z components of the electric field over this region. (b) What is the magnitude of the field at the point P that has coordinates $(1.00, 0, -2.00)$ m?
40. Figure P25.40 shows several equipotential lines, each labeled by its potential in volts. The distance between the lines of the square grid represents 1.00 cm. (a) Is the magnitude of the field larger at A or at B ? Explain how you can tell. (b) Explain what you can determine



Numerical values are in volts.

Figure P25.40

about \vec{E} at B . (c) Represent what the electric field looks like by drawing at least eight field lines.

41. The electric potential inside a charged spherical conductor of radius R is given by $V = k_e Q/R$, and the potential outside is given by $V = k_e Q/r$. Using $E_r = -dV/dr$, derive the electric field (a) inside and (b) outside this charge distribution.
42. It is shown in Example 25.7 that the potential at a point P a distance a above one end of a uniformly charged rod of length ℓ lying along the x axis is

$$V = k_e \frac{Q}{\ell} \ln \left(\frac{\ell + \sqrt{a^2 + \ell^2}}{a} \right)$$

Use this result to derive an expression for the y component of the electric field at P .

Section 25.5 Electric Potential Due to Continuous Charge Distributions

43. Consider a ring of radius R with the total charge Q spread uniformly over its perimeter. What is the potential difference between the point at the center of the ring and a point on its axis a distance $2R$ from the center?
44. A uniformly charged insulating rod of length 14.0 cm is bent into the shape of a semicircle as shown in Figure P25.44. The rod has a total charge of $-7.50 \mu\text{C}$. Find the electric potential at O , the center of the semicircle.

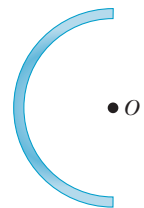

Figure P25.44

45. A rod of length L (Fig. P25.45) lies along the x axis with its left end at the origin. It has a nonuniform charge

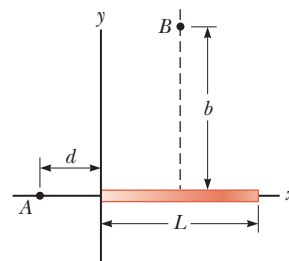

Figure P25.45 Problems 45 and 46.

- density $\lambda = \alpha x$, where α is a positive constant. (a) What are the units of α ? (b) Calculate the electric potential at A .
46. For the arrangement described in Problem 45, calculate the electric potential at point B , which lies on the perpendicular bisector of the rod a distance b above the x axis.
47. A wire having a uniform linear charge density λ is bent into the shape shown in Figure P25.47. Find the electric potential at point O .

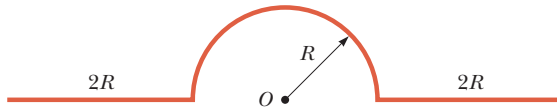

Figure P25.47

Section 25.6 Electric Potential Due to a Charged Conductor

48. The electric field magnitude on the surface of an irregularly shaped conductor varies from 56.0 kN/C to 28.0 kN/C . Can you evaluate the electric potential on the conductor? If so, find its value. If not, explain why not.
49. How many electrons should be removed from an initially uncharged spherical conductor of radius 0.300 m to produce a potential of 7.50 kV at the surface?
50. A spherical conductor has a radius of 14.0 cm and a charge of $26.0 \mu\text{C}$. Calculate the electric field and the electric potential at (a) $r = 10.0 \text{ cm}$, (b) $r = 20.0 \text{ cm}$, and (c) $r = 14.0 \text{ cm}$ from the center.
51. Electric charge can accumulate on an airplane in flight. You may have observed needle-shaped metal extensions on the wing tips and tail of an airplane. Their purpose is to allow charge to leak off before much of it accumulates. The electric field around the needle is much larger than the field around the body of the airplane and can become large enough to produce dielectric breakdown of the air, discharging the airplane. To model this process, assume two charged spherical conductors are connected by a long conducting wire and a $1.20\text{-}\mu\text{C}$ charge is placed on the combination. One sphere, representing the body of the airplane, has a radius of 6.00 cm ; the other, representing the tip of the needle, has a radius of 2.00 cm . (a) What is the electric potential of each sphere? (b) What is the electric field at the surface of each sphere?

Section 25.8 Applications of Electrostatics

52. Lightning can be studied with a Van de Graaff generator, which consists of a spherical dome on which charge is continuously deposited by a moving belt. Charge can be added until the electric field at the surface of the dome becomes equal to the

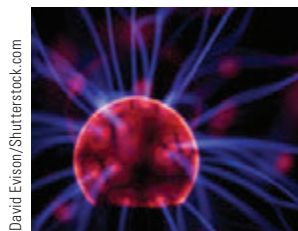

Figure P25.52

dielectric strength of air. Any more charge leaks off in sparks as shown in Figure P25.52. Assume the dome has a diameter of 30.0 cm and is surrounded by dry air with a “breakdown” electric field of $3.00 \times 10^6 \text{ V/m}$. (a) What is the maximum potential of the dome? (b) What is the maximum charge on the dome?

Additional Problems

53. *Why is the following situation impossible?* In the Bohr model of the hydrogen atom, an electron moves in a circular orbit about a proton. The model states that the electron can exist only in certain allowed orbits around the proton: those whose radius r satisfies $r = n^2(0.0529 \text{ nm})$, where $n = 1, 2, 3, \dots$. For one of the possible allowed states of the atom, the electric potential energy of the system is -13.6 eV .
54. **Review.** In fair weather, the electric field in the air at a particular location immediately above the Earth’s surface is 120 N/C directed downward. (a) What is the surface charge density on the ground? Is it positive or negative? (b) Imagine the surface charge density is uniform over the planet. What then is the charge of the whole surface of the Earth? (c) What is the Earth’s electric potential due to this charge? (d) What is the difference in potential between the head and the feet of a person 1.75 m tall? (Ignore any charges in the atmosphere.) (e) Imagine the Moon, with 27.3% of the radius of the Earth, had a charge 27.3% as large, with the same sign. Find the electric force the Earth would then exert on the Moon. (f) State how the answer to part (e) compares with the gravitational force the Earth exerts on the Moon.
55. **Review.** From a large distance away, a particle of mass 2.00 g and charge $15.0 \mu\text{C}$ is fired at $21.0 \hat{i} \text{ m/s}$ straight toward a second particle, originally stationary but free to move, with mass 5.00 g and charge $8.50 \mu\text{C}$. Both particles are constrained to move only along the x axis. (a) At the instant of closest approach, both particles will be moving at the same velocity. Find this velocity. (b) Find the distance of closest approach. After the interaction, the particles will move far apart again. At this time, find the velocity of (c) the 2.00-g particle and (d) the 5.00-g particle.
56. **Review.** From a large distance away, a particle of mass m_1 and positive charge q_1 is fired at speed v in the positive x direction straight toward a second particle, originally stationary but free to move, with mass m_2 and positive charge q_2 . Both particles are constrained to move only along the x axis. (a) At the instant of closest approach, both particles will be moving at the same velocity. Find this velocity. (b) Find the distance of closest approach. After the interaction, the particles will move far apart again. At this time, find the velocity of (c) the particle of mass m_1 and (d) the particle of mass m_2 .
57. The liquid-drop model of the atomic nucleus suggests high-energy oscillations of certain nuclei can split the nucleus into two unequal fragments plus a few

neutrons. The fission products acquire kinetic energy from their mutual Coulomb repulsion. Assume the charge is distributed uniformly throughout the volume of each spherical fragment and, immediately before separating, each fragment is at rest and their surfaces are in contact. The electrons surrounding the nucleus can be ignored. Calculate the electric potential energy (in electron volts) of two spherical fragments from a uranium nucleus having the following charges and radii: $38e$ and 5.50×10^{-15} m, and $54e$ and 6.20×10^{-15} m.

58. On a dry winter day, you scuff your leather-soled shoes across a carpet and get a shock when you extend the tip of one finger toward a metal doorknob. In a dark room, you see a spark perhaps 5 mm long. Make order-of-magnitude estimates of (a) your electric potential and (b) the charge on your body before you touch the doorknob. Explain your reasoning.
59. The electric potential immediately outside a charged conducting sphere is 200 V, and 10.0 cm farther from the center of the sphere the potential is 150 V. Determine (a) the radius of the sphere and (b) the charge on it. The electric potential immediately outside another charged conducting sphere is 210 V, and 10.0 cm farther from the center the magnitude of the electric field is 400 V/m. Determine (c) the radius of the sphere and (d) its charge on it. (e) Are the answers to parts (c) and (d) unique?
60. (a) Use the exact result from Example 25.4 to find the electric potential created by the dipole described in the example at the point $(3a, 0)$. (b) Explain how this answer compares with the result of the approximate expression that is valid when x is much greater than a .
61. Calculate the work that must be done on charges brought from infinity to charge a spherical shell of radius $R = 0.100$ m to a total charge $Q = 125 \mu\text{C}$.
62. Calculate the work that must be done on charges brought from infinity to charge a spherical shell of radius R to a total charge Q .

63. The electric potential everywhere on the xy plane is

$$V = \frac{36}{\sqrt{(x+1)^2 + y^2}} - \frac{45}{\sqrt{x^2 + (y-2)^2}}$$

where V is in volts and x and y are in meters. Determine the position and charge on each of the particles that create this potential.

64. Why is the following situation impossible? You set up an apparatus in your laboratory as follows. The x axis is the symmetry axis of a stationary, uniformly charged ring of radius $R = 0.500$ m and charge $Q = 50.0 \mu\text{C}$ (Fig. P25.64). You place a particle with charge

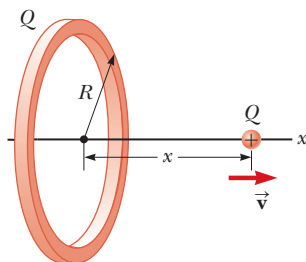

Figure P25.64

$Q = 50.0 \mu\text{C}$ and mass $m = 0.100$ kg at the center of the ring and arrange for it to be constrained to move only along the x axis. When it is displaced slightly, the particle is repelled by the ring and accelerates along the x axis. The particle moves faster than you expected and strikes the opposite wall of your laboratory at 40.0 m/s.

65. From Gauss's law, the electric field set up by a uniform line of charge is

$$\vec{E} = \left(\frac{\lambda}{2\pi\epsilon_0 r} \right) \hat{r}$$

where \hat{r} is a unit vector pointing radially away from the line and λ is the linear charge density along the line. Derive an expression for the potential difference between $r = r_1$ and $r = r_2$.

66. A uniformly charged filament lies along the x axis between $x = a = 1.00$ m and $x = a + \ell = 3.00$ m as shown in Figure P25.66. The total charge on the filament is 1.60 nC. Calculate successive approximations for the electric potential at the origin by modeling the filament as (a) a single charged particle at $x = 2.00$ m, (b) two 0.800-nC charged particles at $x = 1.5$ m and $x = 2.5$ m, and (c) four 0.400-nC charged particles at $x = 1.25$ m, $x = 1.75$ m, $x = 2.25$ m, and $x = 2.75$ m. (d) Explain how the results compare with the potential given by the exact expression

$$V = \frac{k_e Q}{\ell} \ln \left(\frac{\ell + a}{a} \right)$$

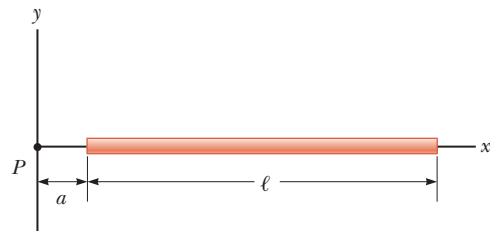

Figure P25.66

67. The thin, uniformly charged rod shown in Figure P25.67 has a linear charge density λ . Find an expression for the electric potential at P .

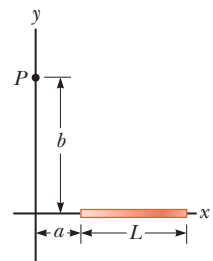

Figure P25.67

68. A Geiger-Mueller tube is a radiation detector that consists of a closed, hollow, metal cylinder (the cathode) of inner radius r_a and a coaxial cylindrical wire (the anode) of radius r_b (Fig. P25.68a).

The charge per unit length on the anode is λ , and the charge per unit length on the cathode is $-\lambda$. A gas fills the space between the electrodes. When the tube is in use (Fig. P25.68b) and a high-energy elementary particle passes through this space, it can ionize an atom of the gas. The strong electric field makes the resulting ion and electron accelerate in opposite directions. They strike other molecules of the gas to ionize them, producing an avalanche of electrical discharge. The

pulse of electric current between the wire and the cylinder is counted by an external circuit. (a) Show that the magnitude of the electric potential difference between the wire and the cylinder is

$$\Delta V = 2k_e \lambda \ln \left(\frac{r_a}{r_b} \right)$$

(b) Show that the magnitude of the electric field in the space between cathode and anode is

$$E = \frac{\Delta V}{\ln(r_a/r_b)} \left(\frac{1}{r} \right)$$

where r is the distance from the axis of the anode to the point where the field is to be calculated.

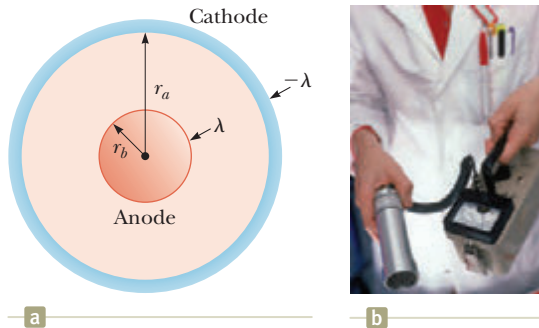

Figure P25.68

69. **Review.** Two parallel plates having charges of equal magnitude but opposite sign are separated by 12.0 cm. Each plate has a surface charge density of 36.0 nC/m². A proton is released from rest at the positive plate. Determine (a) the magnitude of the electric field between the plates from the charge density, (b) the potential difference between the plates, (c) the kinetic energy of the proton when it reaches the negative plate, (d) the speed of the proton just before it strikes the negative plate, (e) the acceleration of the proton, and (f) the force on the proton. (g) From the force, find the magnitude of the electric field. (h) How does your value of the electric field compare with that found in part (a)?
70. When an uncharged conducting sphere of radius a is placed at the origin of an xyz coordinate system that lies in an initially uniform electric field $\vec{E} = E_0 \hat{k}$, the resulting electric potential is $V(x, y, z) = V_0$ for points inside the sphere and

$$V(x, y, z) = V_0 - E_0 z + \frac{E_0 a^3 z}{(x^2 + y^2 + z^2)^{3/2}}$$

for points outside the sphere, where V_0 is the (constant) electric potential on the conductor. Use this equation to determine the x , y , and z components of the resulting electric field (a) inside the sphere and (b) outside the sphere.

Challenge Problems

71. An electric dipole is located along the y axis as shown in Figure P25.71. The magnitude of its electric dipole moment is defined as $p = 2aq$. (a) At a point P , which

is far from the dipole ($r \gg a$), show that the electric potential is

$$V = \frac{k_e p \cos \theta}{r^2}$$

(b) Calculate the radial component E_r and the perpendicular component E_θ of the associated electric field. Note that $E_\theta = -(1/r)(\partial V/\partial \theta)$. Do these results seem reasonable for (c) $\theta = 90^\circ$ and 0° ? (d) For $r = 0$? (e) For the dipole arrangement shown in Figure P25.71, express V in terms of Cartesian coordinates using $r = (x^2 + y^2)^{1/2}$ and

$$\cos \theta = \frac{y}{(x^2 + y^2)^{1/2}}$$

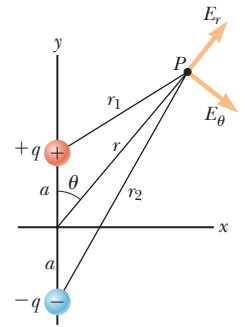

Figure P25.71

(f) Using these results and again taking $r \gg a$, calculate the field components E_x and E_y .

72. A solid sphere of radius R has a uniform charge density ρ and total charge Q . Derive an expression for its total electric potential energy. *Suggestion:* Imagine the sphere is constructed by adding successive layers of concentric shells of charge $dq = (4\pi r^2 dr)\rho$ and use $dU = V dq$.

73. A disk of radius R (Fig. P25.73) has a nonuniform surface charge density $\sigma = Cr$, where C is a constant and r is measured from the center of the disk to a point on the surface of the disk. Find (by direct integration) the electric potential at P .

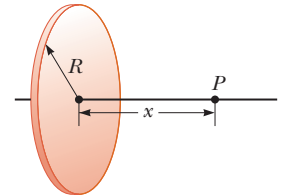

Figure P25.73

74. Four balls, each with mass m , are connected by four nonconducting strings to form a square with side a as shown in Figure P25.74. The assembly is placed on a nonconducting, frictionless, horizontal surface. Balls 1 and 2 each have charge q , and balls 3 and 4 are uncharged. After the string connecting balls 1 and 2 is cut, what is the maximum speed of balls 3 and 4?

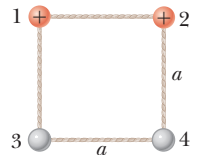

Figure P25.74

75. (a) A uniformly charged cylindrical shell with no end caps has total charge Q , radius R , and length h . Determine the electric potential at a point a distance d from the right end of the cylinder as shown in Figure P25.75.

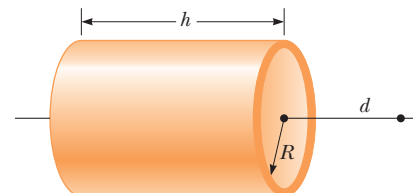

Figure P25.75

Suggestion: Use the result of Example 25.5 by treating the cylinder as a collection of ring charges. (b) **What If?** Use the result of Example 25.6 to solve the same problem for a solid cylinder.

76. As shown in Figure P25.76, two large, parallel, vertical conducting plates separated by distance d are charged so that their potentials are $+V_0$ and $-V_0$. A small conducting ball of mass m and radius R (where $R \ll d$) hangs midway between the plates. The thread of length L supporting the ball is a conducting wire connected to ground, so the potential of the ball is fixed at $V = 0$. The ball hangs straight down in stable equilibrium when V_0 is sufficiently small. Show that

the equilibrium of the ball is unstable if V_0 exceeds the critical value $[k_e d^2 mg / (4RL)]^{1/2}$. *Suggestion:* Consider the forces on the ball when it is displaced a distance $x \ll L$.

77. A particle with charge q is located at $x = -R$, and a particle with charge $-2q$ is located at the origin. Prove that the equipotential surface that has zero potential is a sphere centered at $(-4R/3, 0, 0)$ and having a radius $r = \frac{2}{3}R$.

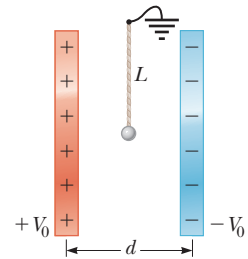

Figure P25.76

Capacitance and Dielectrics



- 26.1 Definition of Capacitance
- 26.2 Calculating Capacitance
- 26.3 Combinations of Capacitors
- 26.4 Energy Stored in a Charged Capacitor
- 26.5 Capacitors with Dielectrics
- 26.6 Electric Dipole in an Electric Field
- 26.7 An Atomic Description of Dielectrics

In this chapter, we introduce the first of three simple circuit elements that can be connected with wires to form an electric circuit. Electric circuits are the basis for the vast majority of the devices used in our society. Here we shall discuss *capacitors*, devices that store electric charge. This discussion is followed by the study of *resistors* in Chapter 27 and *inductors* in Chapter 32. In later chapters, we will study more sophisticated circuit elements such as *diodes* and *transistors*.

Capacitors are commonly used in a variety of electric circuits. For instance, they are used to tune the frequency of radio receivers, as filters in power supplies, to eliminate sparking in automobile ignition systems, and as energy-storing devices in electronic flash units.

26.1 Definition of Capacitance

Consider two conductors as shown in Figure 26.1 (page 778). Such a combination of two conductors is called a **capacitor**. The conductors are called *plates*. If the conductors carry charges of equal magnitude and opposite sign, a potential difference ΔV exists between them.

When a patient receives a shock from a defibrillator, the energy delivered to the patient is initially stored in a *capacitor*. We will study capacitors and capacitance in this chapter. (Andrew Olney/Getty Images)

Pitfall Prevention 26.1

Capacitance Is a Capacity To understand capacitance, think of similar notions that use a similar word. The *capacity* of a milk carton is the volume of milk it can store. The *heat capacity* of an object is the amount of energy an object can store per unit of temperature difference. The *capacitance* of a capacitor is the amount of charge the capacitor can store per unit of potential difference.

Pitfall Prevention 26.2**Potential Difference Is ΔV , Not V**

We use the symbol ΔV for the potential difference across a circuit element or a device because this notation is consistent with our definition of potential difference and with the meaning of the delta sign. It is a common but confusing practice to use the symbol V without the delta sign for both a potential and a potential difference. Keep that in mind if you consult other texts.

Definition of capacitance ▶

When the capacitor is connected to the terminals of a battery, electrons transfer between the plates and the wires so that the plates become charged.

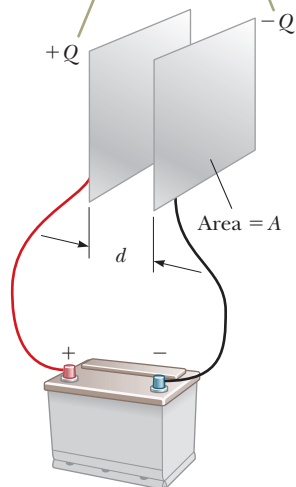
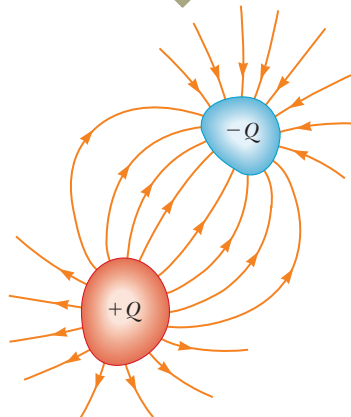

Figure 26.2 A parallel-plate capacitor consists of two parallel conducting plates, each of area A , separated by a distance d .

Figure 26.1 A capacitor consists of two conductors.

When the capacitor is charged, the conductors carry charges of equal magnitude and opposite sign.



What determines how much charge is on the plates of a capacitor for a given voltage? Experiments show that the quantity of charge Q on a capacitor¹ is linearly proportional to the potential difference between the conductors; that is, $Q \propto \Delta V$. The proportionality constant depends on the shape and separation of the conductors.² This relationship can be written as $Q = C \Delta V$ if we define capacitance as follows:

The **capacitance** C of a capacitor is defined as the ratio of the magnitude of the charge on either conductor to the magnitude of the potential difference between the conductors:

$$C \equiv \frac{Q}{\Delta V} \quad (26.1)$$

By definition *capacitance is always a positive quantity*. Furthermore, the charge Q and the potential difference ΔV are always expressed in Equation 26.1 as positive quantities.

From Equation 26.1, we see that capacitance has SI units of coulombs per volt. Named in honor of Michael Faraday, the SI unit of capacitance is the **farad** (F):

$$1 \text{ F} = 1 \text{ C/V}$$

The farad is a very large unit of capacitance. In practice, typical devices have capacitances ranging from microfarads (10^{-6} F) to picofarads (10^{-12} F). We shall use the symbol μF to represent microfarads. In practice, to avoid the use of Greek letters, physical capacitors are often labeled “mF” for microfarads and “mmF” for micromicrofarads or, equivalently, “pF” for picofarads.

Let’s consider a capacitor formed from a pair of parallel plates as shown in Figure 26.2. Each plate is connected to one terminal of a battery, which acts as a source of potential difference. If the capacitor is initially uncharged, the battery establishes an electric field in the connecting wires when the connections are made. Let’s focus on the plate connected to the negative terminal of the battery. The electric field in the wire applies a force on electrons in the wire immediately outside this plate; this force causes the electrons to move onto the plate. The movement continues until the plate, the wire, and the terminal are all at the same electric potential. Once this equilibrium situation is attained, a potential difference no longer exists between the terminal and the plate; as a result, no electric field is present in the wire and

¹Although the total charge on the capacitor is zero (because there is as much excess positive charge on one conductor as there is excess negative charge on the other), it is common practice to refer to the magnitude of the charge on either conductor as “the charge on the capacitor.”

²The proportionality between Q and ΔV can be proven from Coulomb’s law or by experiment.

the electrons stop moving. The plate now carries a negative charge. A similar process occurs at the other capacitor plate, where electrons move from the plate to the wire, leaving the plate positively charged. In this final configuration, the potential difference across the capacitor plates is the same as that between the terminals of the battery.

- Quick Quiz 26.1** A capacitor stores charge Q at a potential difference ΔV . What happens if the voltage applied to the capacitor by a battery is doubled to $2\Delta V$?
- (a) The capacitance falls to half its initial value, and the charge remains the same.
 - (b) The capacitance and the charge both fall to half their initial values.
 - (c) The capacitance and the charge both double.
 - (d) The capacitance remains the same, and the charge doubles.

26.2 Calculating Capacitance

We can derive an expression for the capacitance of a pair of oppositely charged conductors having a charge of magnitude Q in the following manner. First we calculate the potential difference using the techniques described in Chapter 25. We then use the expression $C = Q/\Delta V$ to evaluate the capacitance. The calculation is relatively easy if the geometry of the capacitor is simple.

Although the most common situation is that of two conductors, a single conductor also has a capacitance. For example, imagine a single spherical, charged conductor. The electric field lines around this conductor are exactly the same as if there were a conducting, spherical shell of infinite radius, concentric with the sphere and carrying a charge of the same magnitude but opposite sign. Therefore, we can identify the imaginary shell as the second conductor of a two-conductor capacitor. The electric potential of the sphere of radius a is simply $k_e Q/a$ (see Section 25.6), and setting $V = 0$ for the infinitely large shell gives

$$C = \frac{Q}{\Delta V} = \frac{Q}{k_e Q/a} = \frac{a}{k_e} = 4\pi\epsilon_0 a \quad (26.2)$$

This expression shows that the capacitance of an isolated, charged sphere is proportional to its radius and is independent of both the charge on the sphere and its potential, as is the case with all capacitors. Equation 26.1 is the general definition of capacitance in terms of electrical parameters, but the capacitance of a given capacitor will depend only on the geometry of the plates.

The capacitance of a pair of conductors is illustrated below with three familiar geometries, namely, parallel plates, concentric cylinders, and concentric spheres. In these calculations, we assume the charged conductors are separated by a vacuum.

Parallel-Plate Capacitors

Two parallel, metallic plates of equal area A are separated by a distance d as shown in Figure 26.2. One plate carries a charge $+Q$, and the other carries a charge $-Q$. The surface charge density on each plate is $\sigma = Q/A$. If the plates are very close together (in comparison with their length and width), we can assume the electric field is uniform between the plates and zero elsewhere. According to the What If? feature of Example 24.5, the value of the electric field between the plates is

$$E = \frac{\sigma}{\epsilon_0} = \frac{Q}{\epsilon_0 A}$$

Because the field between the plates is uniform, the magnitude of the potential difference between the plates equals Ed (see Eq. 25.6); therefore,

$$\Delta V = Ed = \frac{Qd}{\epsilon_0 A}$$

Pitfall Prevention 26.3

Too Many Cs Do not confuse an italic C for capacitance with a non-italic C for the unit coulomb.

◀ Capacitance of an isolated charged sphere

Substituting this result into Equation 26.1, we find that the capacitance is

$$C = \frac{Q}{\Delta V} = \frac{Q}{Qd/\epsilon_0 A}$$

$$C = \frac{\epsilon_0 A}{d} \quad (26.3)$$

Capacitance of parallel plates ►

That is, the capacitance of a parallel-plate capacitor is proportional to the area of its plates and inversely proportional to the plate separation.

Let's consider how the geometry of these conductors influences the capacity of the pair of plates to store charge. As a capacitor is being charged by a battery, electrons flow into the negative plate and out of the positive plate. If the capacitor plates are large, the accumulated charges are able to distribute themselves over a substantial area and the amount of charge that can be stored on a plate for a given potential difference increases as the plate area is increased. Therefore, it is reasonable that the capacitance is proportional to the plate area A as in Equation 26.3.

Now consider the region that separates the plates. Imagine moving the plates closer together. Consider the situation before any charges have had a chance to move in response to this change. Because no charges have moved, the electric field between the plates has the same value but extends over a shorter distance. Therefore, the magnitude of the potential difference between the plates $\Delta V = Ed$ (Eq. 25.6) is smaller. The difference between this new capacitor voltage and the terminal voltage of the battery appears as a potential difference across the wires connecting the battery to the capacitor, resulting in an electric field in the wires that drives more charge onto the plates and increases the potential difference between the plates. When the potential difference between the plates again matches that of the battery, the flow of charge stops. Therefore, moving the plates closer together causes the charge on the capacitor to increase. If d is increased, the charge decreases. As a result, the inverse relationship between C and d in Equation 26.3 is reasonable.

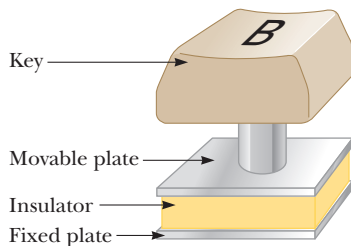

Figure 26.3 (Quick Quiz 26.2) One type of computer keyboard button.

Quick Quiz 26.2 Many computer keyboard buttons are constructed of capacitors as shown in Figure 26.3. When a key is pushed down, the soft insulator between the movable plate and the fixed plate is compressed. When the key is pressed, what happens to the capacitance? (a) It increases. (b) It decreases. (c) It changes in a way you cannot determine because the electric circuit connected to the keyboard button may cause a change in ΔV .

Example 26.1 The Cylindrical Capacitor

A solid cylindrical conductor of radius a and charge Q is coaxial with a cylindrical shell of negligible thickness, radius $b > a$, and charge $-Q$ (Fig. 26.4a). Find the capacitance of this cylindrical capacitor if its length is ℓ .

SOLUTION

Conceptualize Recall that any pair of conductors qualifies as a capacitor, so the system described in this example therefore qualifies. Figure 26.4b helps visualize the electric field between the conductors. We expect the capacitance to depend only on geometric factors, which, in this case, are a , b , and ℓ .

Categorize Because of the cylindrical symmetry of the system, we can use results from previous studies of cylindrical systems to find the capacitance.

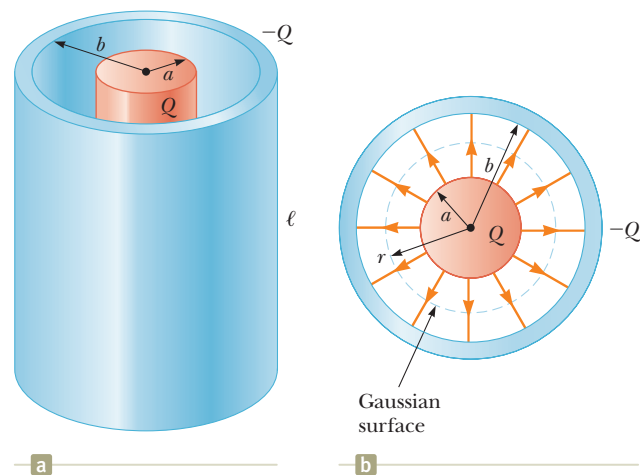

Figure 26.4 (Example 26.1) (a) A cylindrical capacitor consists of a solid cylindrical conductor of radius a and length ℓ surrounded by a coaxial cylindrical shell of radius b . (b) End view. The electric field lines are radial. The dashed line represents the end of a cylindrical gaussian surface of radius r and length ℓ .

26.1 continued

Analyze Assuming ℓ is much greater than a and b , we can neglect end effects. In this case, the electric field is perpendicular to the long axis of the cylinders and is confined to the region between them (Fig. 26.4b).

Write an expression for the potential difference between the two cylinders from Equation 25.3:

$$V_b - V_a = - \int_a^b \vec{\mathbf{E}} \cdot d\vec{\mathbf{s}}$$

Apply Equation 24.7 for the electric field outside a cylindrically symmetric charge distribution and notice from Figure 26.4b that $\vec{\mathbf{E}}$ is parallel to $d\vec{\mathbf{s}}$ along a radial line:

$$V_b - V_a = - \int_a^b E_r dr = -2k_e \lambda \int_a^b \frac{dr}{r} = -2k_e \lambda \ln \left(\frac{b}{a} \right)$$

Substitute the absolute value of ΔV into Equation 26.1 and use $\lambda = Q/\ell$:

$$C = \frac{Q}{\Delta V} = \frac{Q}{(2k_e Q/\ell) \ln(b/a)} = \frac{\ell}{2k_e \ln(b/a)} \quad (26.4)$$

Finalize The capacitance depends on the radii a and b and is proportional to the length of the cylinders. Equation 26.4 shows that the capacitance per unit length of a combination of concentric cylindrical conductors is

$$\frac{C}{\ell} = \frac{1}{2k_e \ln(b/a)} \quad (26.5)$$

An example of this type of geometric arrangement is a *coaxial cable*, which consists of two concentric cylindrical conductors separated by an insulator. You probably have a coaxial cable attached to your television set if you are a subscriber to cable television. The coaxial cable is especially useful for shielding electrical signals from any possible external influences.

WHAT IF? Suppose $b = 2.00a$ for the cylindrical capacitor. You would like to increase the capacitance, and you can do so by choosing to increase either ℓ by 10% or a by 10%. Which choice is more effective at increasing the capacitance?

Answer According to Equation 26.4, C is proportional to ℓ , so increasing ℓ by 10% results in a 10% increase in C . For the result of the change in a , let's use Equation 26.4 to set up a ratio of the capacitance C' for the enlarged cylinder radius a' to the original capacitance:

$$\frac{C'}{C} = \frac{\ell/2k_e \ln(b/a')}{\ell/2k_e \ln(b/a)} = \frac{\ln(b/a)}{\ln(b/a')}$$

We now substitute $b = 2.00a$ and $a' = 1.10a$, representing a 10% increase in a :

$$\frac{C'}{C} = \frac{\ln(2.00a/a)}{\ln(2.00a/1.10a)} = \frac{\ln 2.00}{\ln 1.82} = 1.16$$

which corresponds to a 16% increase in capacitance. Therefore, it is more effective to increase a than to increase ℓ .

Note two more extensions of this problem. First, it is advantageous to increase a only for a range of relationships between a and b . If $b > 2.85a$, increasing ℓ by 10% is more effective than increasing a (see Problem 70). Second, if b decreases, the capacitance increases. Increasing a or decreasing b has the effect of bringing the plates closer together, which increases the capacitance.

Example 26.2 The Spherical Capacitor

A spherical capacitor consists of a spherical conducting shell of radius b and charge $-Q$ concentric with a smaller conducting sphere of radius a and charge Q (Fig. 26.5, page 782). Find the capacitance of this device.

SOLUTION

Conceptualize As with Example 26.1, this system involves a pair of conductors and qualifies as a capacitor. We expect the capacitance to depend on the spherical radii a and b .

continued

26.2 continued

Categorize Because of the spherical symmetry of the system, we can use results from previous studies of spherical systems to find the capacitance.

Analyze As shown in Chapter 24, the direction of the electric field outside a spherically symmetric charge distribution is radial and its magnitude is given by the expression $E = k_e Q / r^2$. In this case, this result applies to the field *between* the spheres ($a < r < b$).

Write an expression for the potential difference between the two conductors from Equation 25.3:

Apply the result of Example 24.3 for the electric field outside a spherically symmetric charge distribution and note that \vec{E} is parallel to $d\vec{s}$ along a radial line:

Substitute the absolute value of ΔV into Equation 26.1:

Finalize The capacitance depends on a and b as expected. The potential difference between the spheres in Equation (1) is negative because Q is positive and $b > a$. Therefore, in Equation 26.6, when we take the absolute value, we change $a - b$ to $b - a$. The result is a positive number.

WHAT IF? If the radius b of the outer sphere approaches infinity, what does the capacitance become?

Answer In Equation 26.6, we let $b \rightarrow \infty$:

$$C = \lim_{b \rightarrow \infty} \frac{ab}{k_e(b-a)} = \frac{ab}{k_e(b)} = \frac{a}{k_e} = 4\pi\epsilon_0 a$$

Notice that this expression is the same as Equation 26.2, the capacitance of an isolated spherical conductor.

Figure 26.5 (Example 26.2) A spherical capacitor consists of an inner sphere of radius a surrounded by a concentric spherical shell of radius b . The electric field between the spheres is directed radially outward when the inner sphere is positively charged.

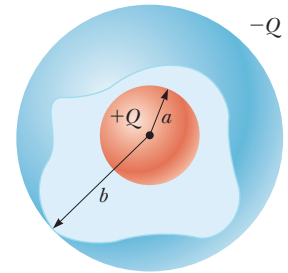

$$V_b - V_a = - \int_a^b \vec{E} \cdot d\vec{s}$$

$$V_b - V_a = - \int_a^b E_r dr = -k_e Q \int_a^b \frac{dr}{r^2} = k_e Q \left[\frac{1}{r} \right]_a^b$$

$$(1) \quad V_b - V_a = k_e Q \left(\frac{1}{b} - \frac{1}{a} \right) = k_e Q \frac{a-b}{ab}$$

$$C = \frac{Q}{\Delta V} = \frac{Q}{|V_b - V_a|} = \frac{ab}{k_e(b-a)} \quad (26.6)$$

Capacitor symbol

Battery symbol

Switch symbol

Figure 26.6 Circuit symbols for capacitors, batteries, and switches. Notice that capacitors are in blue, batteries are in green, and switches are in red. The closed switch can carry current, whereas the open one cannot.

26.3 Combinations of Capacitors

Two or more capacitors often are combined in electric circuits. We can calculate the equivalent capacitance of certain combinations using methods described in this section. Throughout this section, we assume the capacitors to be combined are initially uncharged.

In studying electric circuits, we use a simplified pictorial representation called a **circuit diagram**. Such a diagram uses **circuit symbols** to represent various circuit elements. The circuit symbols are connected by straight lines that represent the wires between the circuit elements. The circuit symbols for capacitors, batteries, and switches as well as the color codes used for them in this text are given in Figure 26.6. The symbol for the capacitor reflects the geometry of the most common model for a capacitor, a pair of parallel plates. The positive terminal of the battery is at the higher potential and is represented in the circuit symbol by the longer line.

Parallel Combination

Two capacitors connected as shown in Figure 26.7a are known as a **parallel combination** of capacitors. Figure 26.7b shows a circuit diagram for this combination of capacitors. The left plates of the capacitors are connected to the positive terminal of the battery by a conducting wire and are therefore both at the same electric potential

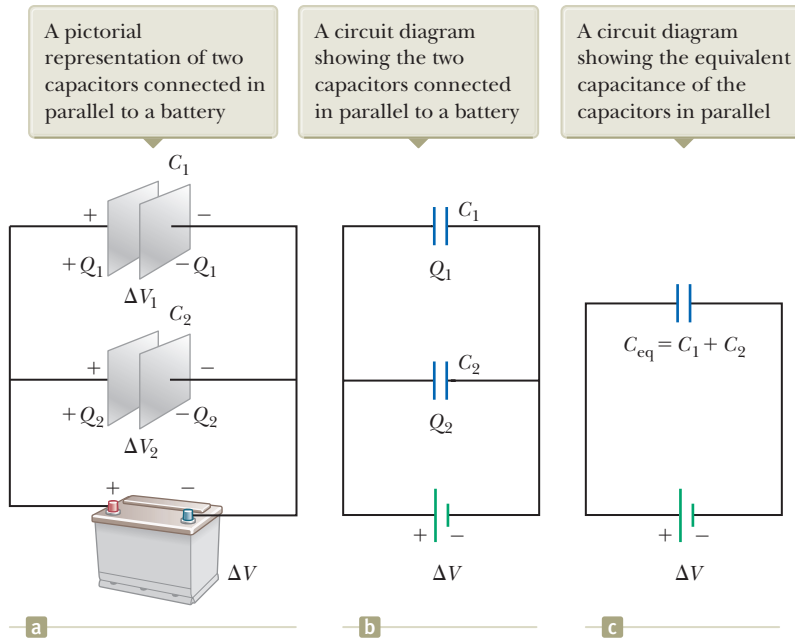

Figure 26.7 Two capacitors connected in parallel. All three diagrams are equivalent.

as the positive terminal. Likewise, the right plates are connected to the negative terminal and so are both at the same potential as the negative terminal. Therefore, the individual potential differences across capacitors connected in parallel are the same and are equal to the potential difference applied across the combination. That is,

$$\Delta V_1 = \Delta V_2 = \Delta V$$

where ΔV is the battery terminal voltage.

After the battery is attached to the circuit, the capacitors quickly reach their maximum charge. Let's call the maximum charges on the two capacitors Q_1 and Q_2 , where $Q_1 = C_1\Delta V_1$ and $Q_2 = C_2\Delta V_2$. The *total charge* Q_{tot} stored by the two capacitors is the sum of the charges on the individual capacitors:

$$Q_{\text{tot}} = Q_1 + Q_2 = C_1\Delta V_1 + C_2\Delta V_2 \quad (26.7)$$

Suppose you wish to replace these two capacitors by one *equivalent capacitor* having a capacitance C_{eq} as in Figure 26.7c. The effect this equivalent capacitor has on the circuit must be exactly the same as the effect of the combination of the two individual capacitors. That is, the equivalent capacitor must store charge Q_{tot} when connected to the battery. Figure 26.7c shows that the voltage across the equivalent capacitor is ΔV because the equivalent capacitor is connected directly across the battery terminals. Therefore, for the equivalent capacitor,

$$Q_{\text{tot}} = C_{\text{eq}} \Delta V$$

Substituting this result into Equation 26.7 gives

$$C_{\text{eq}} \Delta V = C_1 \Delta V_1 + C_2 \Delta V_2$$

$$C_{\text{eq}} = C_1 + C_2 \quad (\text{parallel combination})$$

where we have canceled the voltages because they are all the same. If this treatment is extended to three or more capacitors connected in parallel, the **equivalent capacitance** is found to be

$$C_{\text{eq}} = C_1 + C_2 + C_3 + \cdots \quad (\text{parallel combination}) \quad (26.8)$$

◀ Equivalent capacitance for capacitors in parallel

Therefore, the equivalent capacitance of a parallel combination of capacitors is (1) the algebraic sum of the individual capacitances and (2) greater than any of

Figure 26.8 Two capacitors connected in series. All three diagrams are equivalent.

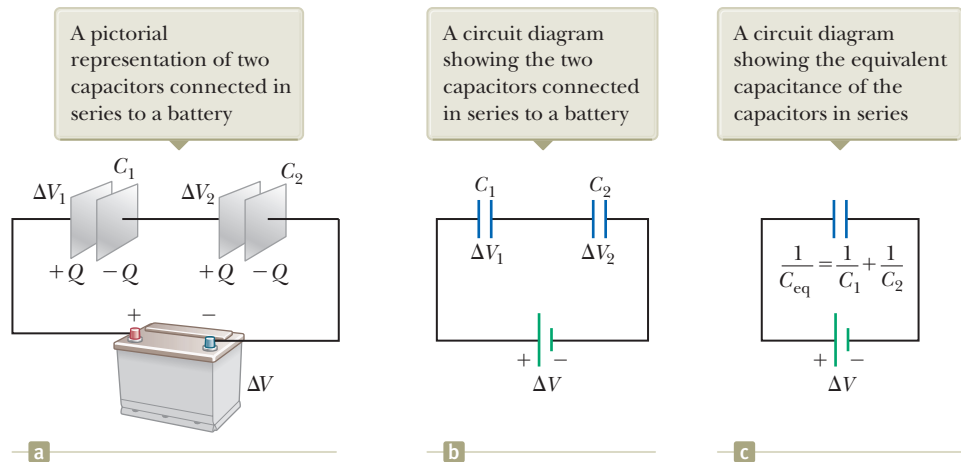

the individual capacitances. Statement (2) makes sense because we are essentially combining the areas of all the capacitor plates when they are connected with conducting wire, and capacitance of parallel plates is proportional to area (Eq. 26.3).

Series Combination

Two capacitors connected as shown in Figure 26.8a and the equivalent circuit diagram in Figure 26.8b are known as a **series combination** of capacitors. The left plate of capacitor 1 and the right plate of capacitor 2 are connected to the terminals of a battery. The other two plates are connected to each other and to nothing else; hence, they form an isolated system that is initially uncharged and must continue to have zero net charge. To analyze this combination, let's first consider the uncharged capacitors and then follow what happens immediately after a battery is connected to the circuit. When the battery is connected, electrons are transferred out of the left plate of C_1 and into the right plate of C_2 . As this negative charge accumulates on the right plate of C_2 , an equivalent amount of negative charge is forced off the left plate of C_2 , and this left plate therefore has an excess positive charge. The negative charge leaving the left plate of C_2 causes negative charges to accumulate on the right plate of C_1 . As a result, both right plates end up with a charge $-Q$ and both left plates end up with a charge $+Q$. Therefore, the charges on capacitors connected in series are the same:

$$Q_1 = Q_2 = Q$$

where Q is the charge that moved between a wire and the connected outside plate of one of the capacitors.

Figure 26.8a shows the individual voltages ΔV_1 and ΔV_2 across the capacitors. These voltages add to give the total voltage ΔV_{tot} across the combination:

$$\Delta V_{\text{tot}} = \Delta V_1 + \Delta V_2 = \frac{Q_1}{C_1} + \frac{Q_2}{C_2} \quad (26.9)$$

In general, the total potential difference across any number of capacitors connected in series is the sum of the potential differences across the individual capacitors.

Suppose the equivalent single capacitor in Figure 26.8c has the same effect on the circuit as the series combination when it is connected to the battery. After it is fully charged, the equivalent capacitor must have a charge of $-Q$ on its right plate and a charge of $+Q$ on its left plate. Applying the definition of capacitance to the circuit in Figure 26.8c gives

$$\Delta V_{\text{tot}} = \frac{Q}{C_{\text{eq}}}$$

Substituting this result into Equation 26.9, we have

$$\frac{Q}{C_{\text{eq}}} = \frac{Q_1}{C_1} + \frac{Q_2}{C_2}$$

Canceling the charges because they are all the same gives

$$\frac{1}{C_{\text{eq}}} = \frac{1}{C_1} + \frac{1}{C_2} \quad (\text{series combination})$$

When this analysis is applied to three or more capacitors connected in series, the relationship for the **equivalent capacitance** is

$$\frac{1}{C_{\text{eq}}} = \frac{1}{C_1} + \frac{1}{C_2} + \frac{1}{C_3} + \cdots \quad (\text{series combination}) \quad (26.10)$$

◀ **Equivalent capacitance for capacitors in series**

This expression shows that (1) the inverse of the equivalent capacitance is the algebraic sum of the inverses of the individual capacitances and (2) the equivalent capacitance of a series combination is always less than any individual capacitance in the combination.

- Quick Quiz 26.3** Two capacitors are identical. They can be connected in series or in parallel. If you want the *smallest* equivalent capacitance for the combination, how should you connect them? (a) in series (b) in parallel (c) either way because both combinations have the same capacitance

Example 26.3 Equivalent Capacitance

Find the equivalent capacitance between *a* and *b* for the combination of capacitors shown in Figure 26.9a. All capacitances are in microfarads.

SOLUTION

Conceptualize Study Figure 26.9a carefully and make sure you understand how the capacitors are connected. Verify that there are only series and parallel connections between capacitors.

Categorize Figure 26.9a shows that the circuit contains both series and parallel connections, so we use the rules for series and parallel combinations discussed in this section.

Analyze Using Equations 26.8 and 26.10, we reduce the combination step by step as indicated in the figure. As you follow along below, notice that in each step we replace the combination of two capacitors in the circuit diagram with a single capacitor having the equivalent capacitance.

The 1.0- μF and 3.0- μF capacitors (upper red-brown circle in Fig. 26.9a) are in parallel. Find the equivalent capacitance from Equation 26.8:

$$C_{\text{eq}} = C_1 + C_2 = 4.0 \mu\text{F}$$

The 2.0- μF and 6.0- μF capacitors (lower red-brown circle in Fig. 26.9a) are also in parallel:

$$C_{\text{eq}} = C_1 + C_2 = 8.0 \mu\text{F}$$

The circuit now looks like Figure 26.9b. The two 4.0- μF capacitors (upper green circle in Fig. 26.9b) are in series. Find the equivalent capacitance from Equation 26.10:

$$\frac{1}{C_{\text{eq}}} = \frac{1}{C_1} + \frac{1}{C_2} = \frac{1}{4.0 \mu\text{F}} + \frac{1}{4.0 \mu\text{F}} = \frac{1}{2.0 \mu\text{F}}$$

$$C_{\text{eq}} = 2.0 \mu\text{F}$$

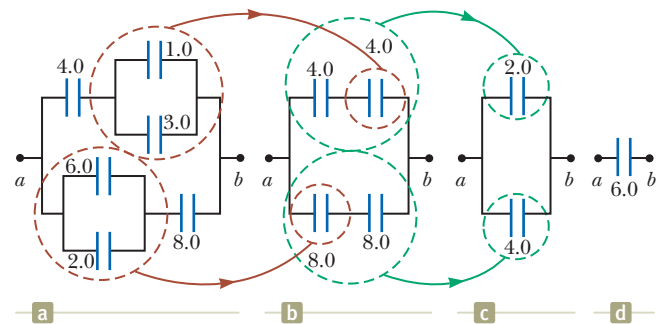

Figure 26.9 (Example 26.3) To find the equivalent capacitance of the capacitors in (a), we reduce the various combinations in steps as indicated in (b), (c), and (d), using the series and parallel rules described in the text. All capacitances are in microfarads.

continued

26.3 continued

The two $8.0\text{-}\mu\text{F}$ capacitors (lower green circle in Fig. 26.9b) are also in series. Find the equivalent capacitance from Equation 26.10:

$$\frac{1}{C_{\text{eq}}} = \frac{1}{C_1} + \frac{1}{C_2} = \frac{1}{8.0\ \mu\text{F}} + \frac{1}{8.0\ \mu\text{F}} = \frac{1}{4.0\ \mu\text{F}}$$

$$C_{\text{eq}} = 4.0\ \mu\text{F}$$

The circuit now looks like Figure 26.9c. The $2.0\text{-}\mu\text{F}$ and $4.0\text{-}\mu\text{F}$ capacitors are in parallel:

$$C_{\text{eq}} = C_1 + C_2 = 6.0\ \mu\text{F}$$

Finalize This final value is that of the single equivalent capacitor shown in Figure 26.9d. For further practice in treating circuits with combinations of capacitors, imagine a battery is connected between points *a* and *b* in Figure 26.9a so that a potential difference ΔV is established across the combination. Can you find the voltage across and the charge on each capacitor?

26.4 Energy Stored in a Charged Capacitor

Because positive and negative charges are separated in the system of two conductors in a capacitor, electric potential energy is stored in the system. Many of those who work with electronic equipment have at some time verified that a capacitor can store energy. If the plates of a charged capacitor are connected by a conductor such as a wire, charge moves between each plate and its connecting wire until the capacitor is uncharged. The discharge can often be observed as a visible spark. If you accidentally touch the opposite plates of a charged capacitor, your fingers act as a pathway for discharge and the result is an electric shock. The degree of shock you receive depends on the capacitance and the voltage applied to the capacitor. Such a shock could be dangerous if high voltages are present as in the power supply of a home theater system. Because the charges can be stored in a capacitor even when the system is turned off, unplugging the system does not make it safe to open the case and touch the components inside.

Figure 26.10a shows a battery connected to a single parallel-plate capacitor with a switch in the circuit. Let us identify the circuit as a system. When the switch is closed (Fig. 26.10b), the battery establishes an electric field in the wires and charges

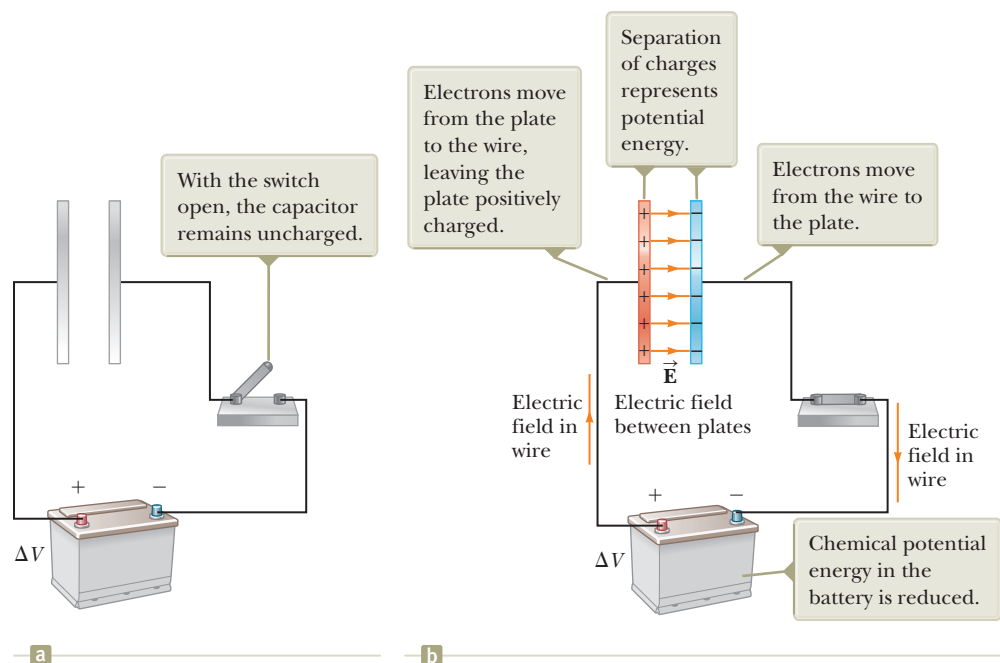

Figure 26.10 (a) A circuit consisting of a capacitor, a battery, and a switch. (b) When the switch is closed, the battery establishes an electric field in the wire and the capacitor becomes charged.

flow between the wires and the capacitor. As that occurs, there is a transformation of energy within the system. Before the switch is closed, energy is stored as chemical potential energy in the battery. This energy is transformed during the chemical reaction that occurs within the battery when it is operating in an electric circuit. When the switch is closed, some of the chemical potential energy in the battery is transformed to electric potential energy associated with the separation of positive and negative charges on the plates.

To calculate the energy stored in the capacitor, we shall assume a charging process that is different from the actual process described in Section 26.1 but that gives the same final result. This assumption is justified because the energy in the final configuration does not depend on the actual charge-transfer process.³ Imagine the plates are disconnected from the battery and you transfer the charge mechanically through the space between the plates as follows. You grab a small amount of positive charge on one plate and apply a force that causes this positive charge to move over to the other plate. Therefore, you do work on the charge as it is transferred from one plate to the other. At first, no work is required to transfer a small amount of charge dq from one plate to the other,⁴ but once this charge has been transferred, a small potential difference exists between the plates. Therefore, work must be done to move additional charge through this potential difference. As more and more charge is transferred from one plate to the other, the potential difference increases in proportion and more work is required. The overall process is described by the nonisolated system model for energy. Equation 8.2 reduces to $W = \Delta U_E$; the work done on the system by the external agent appears as an increase in electric potential energy in the system.

Suppose q is the charge on the capacitor at some instant during the charging process. At the same instant, the potential difference across the capacitor is $\Delta V = q/C$. This relationship is graphed in Figure 26.11. From Section 25.1, we know that the work necessary to transfer an increment of charge dq from the plate carrying charge $-q$ to the plate carrying charge q (which is at the higher electric potential) is

$$dW = \Delta V dq = \frac{q}{C} dq$$

The work required to transfer the charge dq is the area of the tan rectangle in Figure 26.11. Because $1 \text{ V} = 1 \text{ J/C}$, the unit for the area is the joule. The total work required to charge the capacitor from $q = 0$ to some final charge $q = Q$ is

$$W = \int_0^Q \frac{q}{C} dq = \frac{1}{C} \int_0^Q q dq = \frac{Q^2}{2C}$$

The work done in charging the capacitor appears as electric potential energy U_E stored in the capacitor. Using Equation 26.1, we can express the potential energy stored in a charged capacitor as

$$U_E = \frac{Q^2}{2C} = \frac{1}{2}Q\Delta V = \frac{1}{2}C(\Delta V)^2 \quad (26.11)$$

Because the curve in Figure 26.11 is a straight line, the total area under the curve is that of a triangle of base Q and height ΔV .

Equation 26.11 applies to any capacitor, regardless of its geometry. For a given capacitance, the stored energy increases as the charge and the potential difference increase. In practice, there is a limit to the maximum energy (or charge) that can be stored because, at a sufficiently large value of ΔV , discharge ultimately occurs

The work required to move charge dq through the potential difference ΔV across the capacitor plates is given approximately by the area of the shaded rectangle.

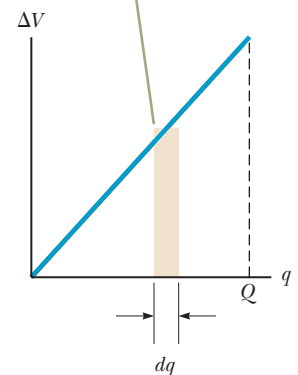

Figure 26.11 A plot of potential difference versus charge for a capacitor is a straight line having slope $1/C$.

◀ **Energy stored in a charged capacitor**

³This discussion is similar to that of state variables in thermodynamics. The change in a state variable such as temperature is independent of the path followed between the initial and final states. The potential energy of a capacitor (or any system) is also a state variable, so its change does not depend on the process followed to charge the capacitor.

⁴We shall use lowercase q for the time-varying charge on the capacitor while it is charging to distinguish it from uppercase Q , which is the total charge on the capacitor after it is completely charged.

Pitfall Prevention 26.4**Not a New Kind of Energy**

The energy given by Equation 26.12 is not a new kind of energy. The equation describes familiar electric potential energy associated with a system of separated source charges. Equation 26.12 provides a new *interpretation*, or a new way of *modeling* the energy. Furthermore, Equation 26.13 correctly describes the energy density associated with *any* electric field, regardless of the source.

Energy density in an electric field ▶

between the plates. For this reason, capacitors are usually labeled with a maximum operating voltage.

We can consider the energy in a capacitor to be stored in the electric field created between the plates as the capacitor is charged. This description is reasonable because the electric field is proportional to the charge on the capacitor. For a parallel-plate capacitor, the potential difference is related to the electric field through the relationship $\Delta V = Ed$. Furthermore, its capacitance is $C = \epsilon_0 A/d$ (Eq. 26.3). Substituting these expressions into Equation 26.11 gives

$$U_E = \frac{1}{2} \left(\frac{\epsilon_0 A}{d} \right) (Ed)^2 = \frac{1}{2} (\epsilon_0 Ad) E^2 \quad (26.12)$$

Because the volume occupied by the electric field is Ad , the *energy per unit volume* $u_E = U_E/Ad$, known as the *energy density*, is

$$u_E = \frac{1}{2} \epsilon_0 E^2 \quad (26.13)$$

Although Equation 26.13 was derived for a parallel-plate capacitor, the expression is generally valid regardless of the source of the electric field. That is, the energy density in any electric field is proportional to the square of the magnitude of the electric field at a given point.

Quick Quiz 26.4 You have three capacitors and a battery. In which of the following combinations of the three capacitors is the maximum possible energy stored when the combination is attached to the battery? (a) series (b) parallel (c) no difference because both combinations store the same amount of energy

Example 26.4 Rewiring Two Charged Capacitors

Two capacitors C_1 and C_2 (where $C_1 > C_2$) are charged to the same initial potential difference ΔV_i . The charged capacitors are removed from the battery, and their plates are connected with opposite polarity as in Figure 26.12a. The switches S_1 and S_2 are then closed as in Figure 26.12b.

(A) Find the final potential difference ΔV_f between a and b after the switches are closed.

SOLUTION

Conceptualize Figure 26.12 helps us understand the initial and final configurations of the system. When the switches are closed, the charge on the system will redistribute between the capacitors until both capacitors have the same potential difference. Because $C_1 > C_2$, more charge exists on C_1 than on C_2 , so the final configuration will have positive charge on the left plates as shown in Figure 26.12b.

Categorize In Figure 26.12b, it might appear as if the capacitors are connected in parallel, but there is no battery in this circuit to apply a voltage across the combination. Therefore, we *cannot* categorize this problem as one in which capacitors are connected in parallel. We *can* categorize it as a problem involving an isolated system for electric charge. The left-hand plates of the capacitors form an isolated system because they are not connected to the right-hand plates by conductors.

Analyze Write an expression for the total charge on the left-hand plates of the system before the switches are closed, noting that a negative sign for Q_{2i} is necessary because the charge on the left plate of capacitor C_2 is negative:

$$(1) \quad Q_i = Q_{1i} + Q_{2i} = C_1 \Delta V_i - C_2 \Delta V_i = (C_1 - C_2) \Delta V_i$$

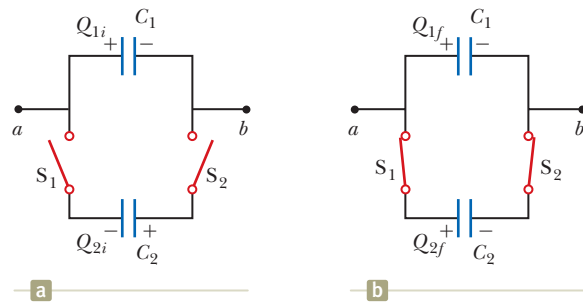

Figure 26.12 (Example 26.4) (a) Two capacitors are charged to the same initial potential difference and connected together with plates of opposite sign to be in contact when the switches are closed. (b) When the switches are closed, the charges redistribute.

► 26.4 continued

After the switches are closed, the charges on the individual capacitors change to new values Q_{1f} and Q_{2f} such that the potential difference is again the same across both capacitors, with a value of ΔV_f . Write an expression for the total charge on the left-hand plates of the system after the switches are closed:

$$(2) \quad Q_f = Q_{1f} + Q_{2f} = C_1 \Delta V_f + C_2 \Delta V_f = (C_1 + C_2) \Delta V_f$$

Because the system is isolated, the initial and final charges on the system must be the same. Use this condition and Equations (1) and (2) to solve for ΔV_f :

$$Q_f = Q_i \rightarrow (C_1 + C_2) \Delta V_f = (C_1 - C_2) \Delta V_i$$

$$(3) \quad \Delta V_f = \left(\frac{C_1 - C_2}{C_1 + C_2} \right) \Delta V_i$$

(B) Find the total energy stored in the capacitors before and after the switches are closed and determine the ratio of the final energy to the initial energy.

SOLUTION

Use Equation 26.11 to find an expression for the total energy stored in the capacitors before the switches are closed:

$$(4) \quad U_i = \frac{1}{2} C_1 (\Delta V_i)^2 + \frac{1}{2} C_2 (\Delta V_i)^2 = \frac{1}{2} (C_1 + C_2) (\Delta V_i)^2$$

Write an expression for the total energy stored in the capacitors after the switches are closed:

$$U_f = \frac{1}{2} C_1 (\Delta V_f)^2 + \frac{1}{2} C_2 (\Delta V_f)^2 = \frac{1}{2} (C_1 + C_2) (\Delta V_f)^2$$

Use the results of part (A) to rewrite this expression in terms of ΔV_i :

$$(5) \quad U_f = \frac{1}{2} (C_1 + C_2) \left[\left(\frac{C_1 - C_2}{C_1 + C_2} \right) \Delta V_i \right]^2 = \frac{1}{2} \frac{(C_1 - C_2)^2 (\Delta V_i)^2}{C_1 + C_2}$$

Divide Equation (5) by Equation (4) to obtain the ratio of the energies stored in the system:

$$\frac{U_f}{U_i} = \frac{\frac{1}{2} (C_1 - C_2)^2 (\Delta V_i)^2 / (C_1 + C_2)}{\frac{1}{2} (C_1 + C_2) (\Delta V_i)^2}$$

$$(6) \quad \frac{U_f}{U_i} = \left(\frac{C_1 - C_2}{C_1 + C_2} \right)^2$$

Finalize The ratio of energies is *less* than unity, indicating that the final energy is *less* than the initial energy. At first, you might think the law of energy conservation has been violated, but that is not the case. The “missing” energy is transferred out of the system by the mechanism of electromagnetic waves (T_{ER} in Eq. 8.2), as we shall see in Chapter 34. Therefore, this system is isolated for electric charge, but nonisolated for energy.

WHAT IF? What if the two capacitors have the same capacitance? What would you expect to happen when the switches are closed?

Answer Because both capacitors have the same initial potential difference applied to them, the charges on the identical capacitors have the same magnitude. When the capacitors with opposite polarities are connected together, the equal-magnitude charges should cancel each other, leaving the capacitors uncharged.

Let's test our results to see if that is the case mathematically. In Equation (1), because the capacitances are equal, the initial charge Q_i on the system of left-hand plates is zero. Equation (3) shows that $\Delta V_f = 0$, which is consistent with uncharged capacitors. Finally, Equation (5) shows that $U_f = 0$, which is also consistent with uncharged capacitors.

One device in which capacitors have an important role is the portable *defibrillator* (see the chapter-opening photo on page 777). When cardiac fibrillation (random contractions) occurs, the heart produces a rapid, irregular pattern of beats. A fast discharge of energy through the heart can return the organ to its normal beat pattern. Emergency medical teams use portable defibrillators that contain batteries capable of charging a capacitor to a high voltage. (The circuitry actually permits the capacitor to be charged to a much higher voltage than that of the battery.) Up to 360 J is stored

in the electric field of a large capacitor in a defibrillator when it is fully charged. The stored energy is released through the heart by conducting electrodes, called paddles, which are placed on both sides of the victim's chest. The defibrillator can deliver the energy to a patient in about 2 ms (roughly equivalent to 3 000 times the power delivered to a 60-W lightbulb!). The paramedics must wait between applications of the energy because of the time interval necessary for the capacitors to become fully charged. In this application and others (e.g., camera flash units and lasers used for fusion experiments), capacitors serve as energy reservoirs that can be slowly charged and then quickly discharged to provide large amounts of energy in a short pulse.

26.5 Capacitors with Dielectrics

Pitfall Prevention 26.5

Is the Capacitor Connected to a Battery?

For problems in which a capacitor is modified (by insertion of a dielectric, for example), you must note whether modifications to the capacitor are being made while the capacitor is connected to a battery or after it is disconnected. If the capacitor remains connected to the battery, the voltage across the capacitor necessarily remains the same. If you disconnect the capacitor from the battery before making any modifications to the capacitor, the capacitor is an isolated system for electric charge and its charge remains the same.

A **dielectric** is a nonconducting material such as rubber, glass, or waxed paper. We can perform the following experiment to illustrate the effect of a dielectric in a capacitor. Consider a parallel-plate capacitor that without a dielectric has a charge Q_0 and a capacitance C_0 . The potential difference across the capacitor is $\Delta V_0 = Q_0/C_0$. Figure 26.13a illustrates this situation. The potential difference is measured by a device called a *voltmeter*. Notice that no battery is shown in the figure; also, we must assume no charge can flow through an ideal voltmeter. Hence, there is no path by which charge can flow and alter the charge on the capacitor. If a dielectric is now inserted between the plates as in Figure 26.13b, the voltmeter indicates that the voltage between the plates decreases to a value ΔV . The voltages with and without the dielectric are related by a factor κ as follows:

$$\Delta V = \frac{\Delta V_0}{\kappa}$$

Because $\Delta V < \Delta V_0$, we see that $\kappa > 1$. The dimensionless factor κ is called the **dielectric constant** of the material. The dielectric constant varies from one material to another. In this section, we analyze this change in capacitance in terms of electrical parameters such as electric charge, electric field, and potential difference; Section 26.7 describes the microscopic origin of these changes.

Because the charge Q_0 on the capacitor does not change, the capacitance must change to the value

$$C = \frac{Q_0}{\Delta V} = \frac{Q_0}{\Delta V_0/\kappa} = \kappa \frac{Q_0}{\Delta V_0}$$

$$C = \kappa C_0$$

(26.14)

Capacitance of a capacitor filled with a material of dielectric constant κ

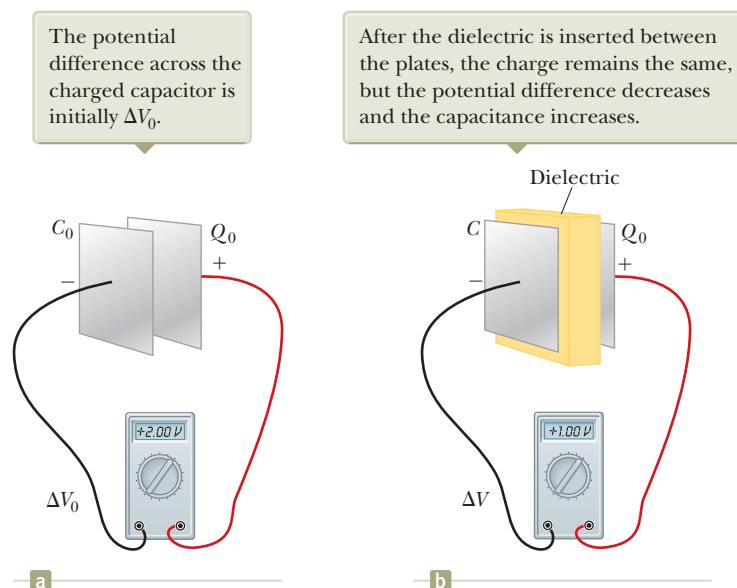

Figure 26.13 A charged capacitor (a) before and (b) after insertion of a dielectric between the plates.

That is, the capacitance *increases* by the factor κ when the dielectric completely fills the region between the plates.⁵ Because $C_0 = \epsilon_0 A/d$ (Eq. 26.3) for a parallel-plate capacitor, we can express the capacitance of a parallel-plate capacitor filled with a dielectric as

$$C = \kappa \frac{\epsilon_0 A}{d} \quad (26.15)$$

From Equation 26.15, it would appear that the capacitance could be made very large by inserting a dielectric between the plates and decreasing d . In practice, the lowest value of d is limited by the electric discharge that could occur through the dielectric medium separating the plates. For any given separation d , the maximum voltage that can be applied to a capacitor without causing a discharge depends on the **dielectric strength** (maximum electric field) of the dielectric. If the magnitude of the electric field in the dielectric exceeds the dielectric strength, the insulating properties break down and the dielectric begins to conduct.

Physical capacitors have a specification called by a variety of names, including *working voltage*, *breakdown voltage*, and *rated voltage*. This parameter represents the largest voltage that can be applied to the capacitor without exceeding the dielectric strength of the dielectric material in the capacitor. Consequently, when selecting a capacitor for a given application, you must consider its capacitance as well as the expected voltage across the capacitor in the circuit, making sure the expected voltage is smaller than the rated voltage of the capacitor.

Insulating materials have values of κ greater than unity and dielectric strengths greater than that of air as Table 26.1 indicates. Therefore, a dielectric provides the following advantages:

- An increase in capacitance
- An increase in maximum operating voltage
- Possible mechanical support between the plates, which allows the plates to be close together without touching, thereby decreasing d and increasing C

Table 26.1 Approximate Dielectric Constants and Dielectric Strengths of Various Materials at Room Temperature

Material	Dielectric Constant κ	Dielectric Strength ^a (10^6 V/m)
Air (dry)	1.000 59	3
Bakelite	4.9	24
Fused quartz	3.78	8
Mylar	3.2	7
Neoprene rubber	6.7	12
Nylon	3.4	14
Paper	3.7	16
Paraffin-impregnated paper	3.5	11
Polystyrene	2.56	24
Polyvinyl chloride	3.4	40
Porcelain	6	12
Pyrex glass	5.6	14
Silicone oil	2.5	15
Strontium titanate	233	8
Teflon	2.1	60
Vacuum	1.000 00	—
Water	80	—

^aThe dielectric strength equals the maximum electric field that can exist in a dielectric without electrical breakdown. These values depend strongly on the presence of impurities and flaws in the materials.

⁵ If the dielectric is introduced while the potential difference is held constant by a battery, the charge increases to a value $Q = \kappa Q_0$. The additional charge comes from the wires attached to the capacitor, and the capacitance again increases by the factor κ .

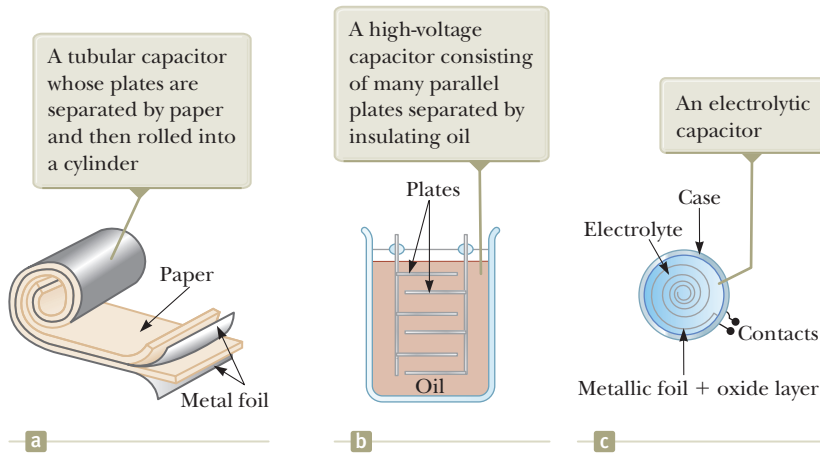

Figure 26.14 Three commercial capacitor designs.

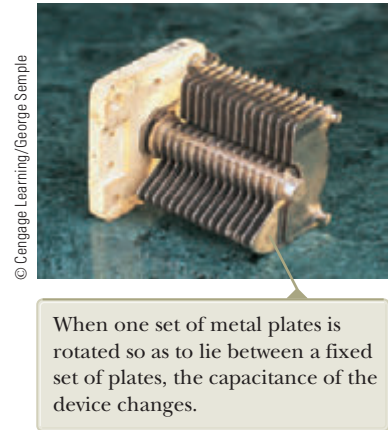

Figure 26.15 A variable capacitor.

Types of Capacitors

Many capacitors are built into integrated circuit chips, but some electrical devices still use stand-alone capacitors. Commercial capacitors are often made from metallic foil interlaced with thin sheets of either paraffin-impregnated paper or Mylar as the dielectric material. These alternate layers of metallic foil and dielectric are rolled into a cylinder to form a small package (Fig. 26.14a). High-voltage capacitors commonly consist of a number of interwoven metallic plates immersed in silicone oil (Fig. 26.14b). Small capacitors are often constructed from ceramic materials.

Often, an *electrolytic capacitor* is used to store large amounts of charge at relatively low voltages. This device, shown in Figure 26.14c, consists of a metallic foil in contact with an *electrolyte*, a solution that conducts electricity by virtue of the motion of ions contained in the solution. When a voltage is applied between the foil and the electrolyte, a thin layer of metal oxide (an insulator) is formed on the foil, and this layer serves as the dielectric. Very large values of capacitance can be obtained in an electrolytic capacitor because the dielectric layer is very thin and therefore the plate separation is very small.

Electrolytic capacitors are not reversible as are many other capacitors. They have a polarity, which is indicated by positive and negative signs marked on the device. When electrolytic capacitors are used in circuits, the polarity must be correct. If the polarity of the applied voltage is the opposite of what is intended, the oxide layer is removed and the capacitor conducts electricity instead of storing charge.

Variable capacitors (typically 10 to 500 pF) usually consist of two interwoven sets of metallic plates, one fixed and the other movable, and contain air as the dielectric (Fig. 26.15). These types of capacitors are often used in radio tuning circuits.

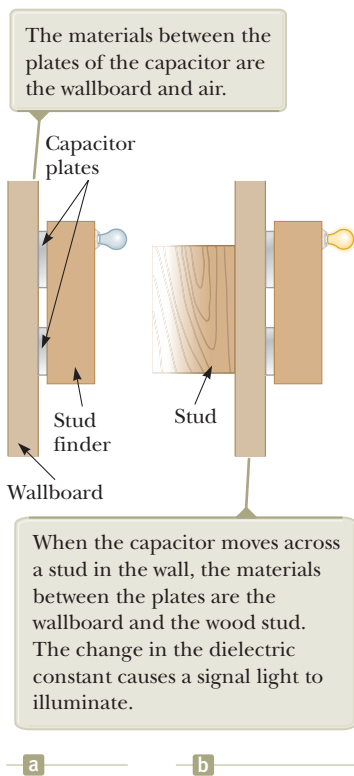

Figure 26.16 (Quick Quiz 26.5) A stud finder.

Quick Quiz 26.5 If you have ever tried to hang a picture or a mirror, you know it can be difficult to locate a wooden stud in which to anchor your nail or screw. A carpenter's stud finder is a capacitor with its plates arranged side by side instead of facing each other as shown in Figure 26.16. When the device is moved over a stud, does the capacitance (a) increase or (b) decrease?

Example 26.5 Energy Stored Before and After AM

A parallel-plate capacitor is charged with a battery to a charge Q_0 . The battery is then removed, and a slab of material that has a dielectric constant κ is inserted between the plates. Identify the system as the capacitor and the dielectric. Find the energy stored in the system before and after the dielectric is inserted.

26.5 continued

SOLUTION

Conceptualize Think about what happens when the dielectric is inserted between the plates. Because the battery has been removed, the charge on the capacitor must remain the same. We know from our earlier discussion, however, that the capacitance must change. Therefore, we expect a change in the energy of the system.

Categorize Because we expect the energy of the system to change, we model it as a *nonisolated system* for energy involving a capacitor and a dielectric.

Analyze From Equation 26.11, find the energy stored in the absence of the dielectric:

$$U_0 = \frac{Q_0^2}{2C_0}$$

Find the energy stored in the capacitor after the dielectric is inserted between the plates:

$$U = \frac{Q_0^2}{2C}$$

Use Equation 26.14 to replace the capacitance C :

$$U = \frac{Q_0^2}{2\kappa C_0} = \frac{U_0}{\kappa}$$

Finalize Because $\kappa > 1$, the final energy is less than the initial energy. We can account for the decrease in energy of the system by performing an experiment and noting that the dielectric, when inserted, is pulled into the device. To keep the dielectric from accelerating, an external agent must do negative work on the dielectric. Equation 8.2 becomes $\Delta U = W$, where both sides of the equation are negative.

26.6 Electric Dipole in an Electric Field

We have discussed the effect on the capacitance of placing a dielectric between the plates of a capacitor. In Section 26.7, we shall describe the microscopic origin of this effect. Before we can do so, however, let's expand the discussion of the electric dipole introduced in Section 23.4 (see Example 23.6). The electric dipole consists of two charges of equal magnitude and opposite sign separated by a distance $2a$ as shown in Figure 26.17. The **electric dipole moment** of this configuration is defined as the vector \vec{p} directed from $-q$ toward $+q$ along the line joining the charges and having magnitude

$$p = 2aq \quad (26.16)$$

Now suppose an electric dipole is placed in a uniform electric field \vec{E} and makes an angle θ with the field as shown in Figure 26.18. We identify \vec{E} as the field *external* to the dipole, established by some other charge distribution, to distinguish it from the field *due* to the dipole, which we discussed in Section 23.4.

Each of the charges is modeled as a particle in an electric field. The electric forces acting on the two charges are equal in magnitude ($F = qE$) and opposite in direction as shown in Figure 26.18. Therefore, the net force on the dipole is zero. The two forces produce a net torque on the dipole, however; the dipole is therefore described by the rigid object under a net torque model. As a result, the dipole rotates in the direction that brings the dipole moment vector into greater alignment with the field. The torque due to the force on the positive charge about an axis through O in Figure 26.18 has magnitude $Fa \sin \theta$, where $a \sin \theta$ is the moment arm of F about O . This force tends to produce a clockwise rotation. The torque about O on the negative charge is also of magnitude $Fa \sin \theta$; here again, the force tends to produce a clockwise rotation. Therefore, the magnitude of the net torque about O is

$$\tau = 2Fa \sin \theta$$

Because $F = qE$ and $p = 2aq$, we can express τ as

$$\tau = 2aqE \sin \theta = pE \sin \theta \quad (26.17)$$

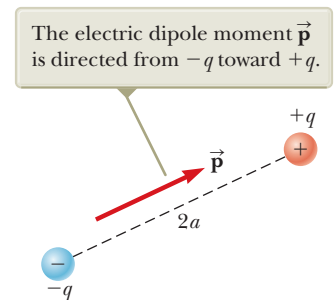

Figure 26.17 An electric dipole consists of two charges of equal magnitude and opposite sign separated by a distance of $2a$.

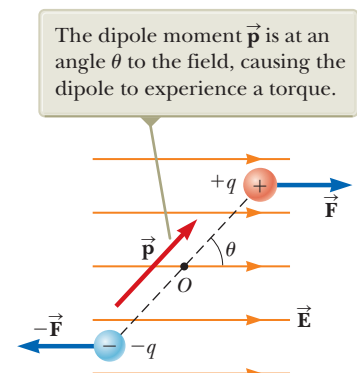

Figure 26.18 An electric dipole in a uniform external electric field.

Based on this expression, it is convenient to express the torque in vector form as the cross product of the vectors \vec{p} and \vec{E} :

$$\vec{\tau} = \vec{p} \times \vec{E} \quad (26.18)$$

Torque on an electric dipole in an external electric field

We can also model the system of the dipole and the external electric field as an isolated system for energy. Let's determine the potential energy of the system as a function of the dipole's orientation with respect to the field. To do so, recognize that work must be done by an external agent to rotate the dipole through an angle so as to cause the dipole moment vector to become less aligned with the field. The work done is then stored as electric potential energy in the system. Notice that this potential energy is associated with a *rotational* configuration of the system. Previously, we have seen potential energies associated with *translational* configurations: an object with mass was moved in a gravitational field, a charge was moved in an electric field, or a spring was extended. The work dW required to rotate the dipole through an angle $d\theta$ is $dW = \tau d\theta$ (see Eq. 10.25). Because $\tau = pE \sin \theta$ and the work results in an increase in the electric potential energy U , we find that for a rotation from θ_i to θ_f , the change in potential energy of the system is

$$\begin{aligned} U_f - U_i &= \int_{\theta_i}^{\theta_f} \tau d\theta = \int_{\theta_i}^{\theta_f} pE \sin \theta d\theta = pE \int_{\theta_i}^{\theta_f} \sin \theta d\theta \\ &= pE[-\cos \theta]_{\theta_i}^{\theta_f} = pE(\cos \theta_i - \cos \theta_f) \end{aligned}$$

The term that contains $\cos \theta_i$ is a constant that depends on the initial orientation of the dipole. It is convenient to choose a reference angle of $\theta_i = 90^\circ$ so that $\cos \theta_i = \cos 90^\circ = 0$. Furthermore, let's choose $U_i = 0$ at $\theta_i = 90^\circ$ as our reference value of potential energy. Hence, we can express a general value of $U_E = U_f$ as

$$U_E = -pE \cos \theta \quad (26.19)$$

We can write this expression for the potential energy of a dipole in an electric field as the dot product of the vectors \vec{p} and \vec{E} :

$$U_E = -\vec{p} \cdot \vec{E} \quad (26.20)$$

Potential energy of the system of an electric dipole in an external electric field

To develop a conceptual understanding of Equation 26.19, compare it with the expression for the potential energy of the system of an object in the Earth's gravitational field, $U_g = mgy$ (Eq. 7.19). First, both expressions contain a parameter of the entity placed in the field: mass for the object, dipole moment for the dipole. Second, both expressions contain the field, g for the object, E for the dipole. Finally, both expressions contain a configuration description: translational position y for the object, rotational position θ for the dipole. In both cases, once the configuration is changed, the system tends to return to the original configuration when the object is released: the object of mass m falls toward the ground, and the dipole begins to rotate back toward the configuration in which it is aligned with the field.

Molecules are said to be *polarized* when a separation exists between the average position of the negative charges and the average position of the positive charges in the molecule. In some molecules such as water, this condition is always present; such molecules are called **polar molecules**. Molecules that do not possess a permanent polarization are called **nonpolar molecules**.

We can understand the permanent polarization of water by inspecting the geometry of the water molecule. The oxygen atom in the water molecule is bonded to the hydrogen atoms such that an angle of 105° is formed between the two bonds (Fig. 26.19). The oxygen atom in the water molecule is bonded to the hydrogen atoms such that an angle of 105° is formed between the two bonds (Fig. 26.19). The center of the negative charge distribution is near the oxygen atom, and the center of the positive charge distribution lies at a point midway along the line joining the hydrogen atoms (the point labeled \times in Fig. 26.19). We can model the water molecule and other polar molecules as dipoles because the average positions of the positive and negative charges act as point charges. As a result, we can apply our discussion of dipoles to the behavior of polar molecules.

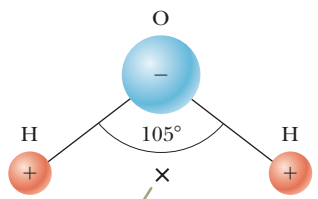

The center of the positive charge distribution is at the point \times .

Figure 26.19 The water molecule, H_2O , has a permanent polarization resulting from its nonlinear geometry.

Washing with soap and water is a household scenario in which the dipole structure of water is exploited. Grease and oil are made up of nonpolar molecules, which are generally not attracted to water. Plain water is not very useful for removing this type of grime. Soap contains long molecules called *surfactants*. In a long molecule, the polarity characteristics of one end of the molecule can be different from those at the other end. In a surfactant molecule, one end acts like a nonpolar molecule and the other acts like a polar molecule. The nonpolar end can attach to a grease or oil molecule, and the polar end can attach to a water molecule. Therefore, the soap serves as a chain, linking the dirt and water molecules together. When the water is rinsed away, the grease and oil go with it.

A symmetric molecule (Fig. 26.20a) has no permanent polarization, but polarization can be induced by placing the molecule in an electric field. A field directed to the left as in Figure 26.20b causes the center of the negative charge distribution to shift to the right relative to the positive charges. This *induced polarization* is the effect that predominates in most materials used as dielectrics in capacitors.

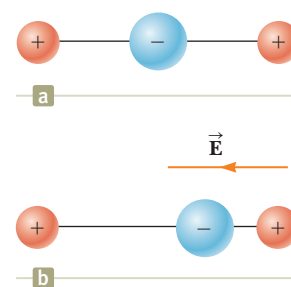

Figure 26.20 (a) A linear symmetric molecule has no permanent polarization. (b) An external electric field induces a polarization in the molecule.

Example 26.6 The H₂O Molecule AM

The water (H₂O) molecule has an electric dipole moment of $6.3 \times 10^{-30} \text{ C} \cdot \text{m}$. A sample contains 10^{21} water molecules, with the dipole moments all oriented in the direction of an electric field of magnitude $2.5 \times 10^5 \text{ N/C}$. How much work is required to rotate the dipoles from this orientation ($\theta = 0^\circ$) to one in which all the moments are perpendicular to the field ($\theta = 90^\circ$)?

SOLUTION

Conceptualize When all the dipoles are aligned with the electric field, the dipoles–electric field system has the minimum potential energy. This energy has a negative value given by the product of the right side of Equation 26.19, evaluated at 0° , and the number N of dipoles.

Categorize The combination of the dipoles and the electric field is identified as a system. We use the *nonisolated system* model because an external agent performs work on the system to change its potential energy.

Analyze Write the appropriate reduction of the conservation of energy equation, Equation 8.2, for this situation:

$$(1) \quad \Delta U_E = W$$

Use Equation 26.19 to evaluate the initial and final potential energies of the system and Equation (1) to calculate the work required to rotate the dipoles:

$$\begin{aligned} W &= U_{90^\circ} - U_{0^\circ} = (-NpE \cos 90^\circ) - (-NpE \cos 0^\circ) \\ &= NpE = (10^{21})(6.3 \times 10^{-30} \text{ C} \cdot \text{m})(2.5 \times 10^5 \text{ N/C}) \\ &= 1.6 \times 10^{-3} \text{ J} \end{aligned}$$

Finalize Notice that the work done on the system is positive because the potential energy of the system has been raised from a negative value to a value of zero.

26.7 An Atomic Description of Dielectrics

In Section 26.5, we found that the potential difference ΔV_0 between the plates of a capacitor is reduced to $\Delta V_0/\kappa$ when a dielectric is introduced. The potential difference is reduced because the magnitude of the electric field decreases between the plates. In particular, if \vec{E}_0 is the electric field without the dielectric, the field in the presence of a dielectric is

$$\vec{E} = \frac{\vec{E}_0}{\kappa} \quad (26.21)$$

First consider a dielectric made up of polar molecules placed in the electric field between the plates of a capacitor. The dipoles (that is, the polar molecules making

Figure 26.21 (a) Polar molecules in a dielectric. (b) An electric field is applied to the dielectric. (c) Details of the electric field inside the dielectric.

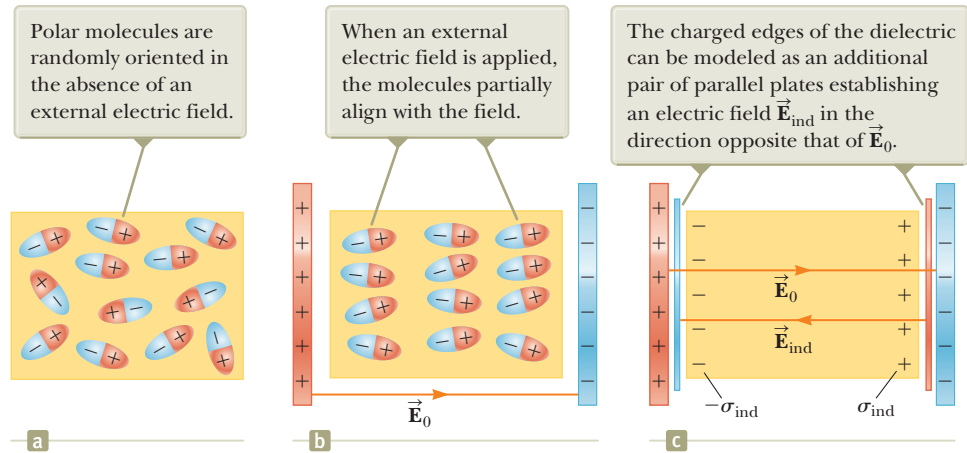

up the dielectric) are randomly oriented in the absence of an electric field as shown in Figure 26.21a. When an external field \vec{E}_0 due to charges on the capacitor plates is applied, a torque is exerted on the dipoles, causing them to partially align with the field as shown in Figure 26.21b. The dielectric is now polarized. The degree of alignment of the molecules with the electric field depends on temperature and the magnitude of the field. In general, the alignment increases with decreasing temperature and with increasing electric field.

If the molecules of the dielectric are nonpolar, the electric field due to the plates produces an induced polarization in the molecule. These induced dipole moments tend to align with the external field, and the dielectric is polarized. Therefore, a dielectric can be polarized by an external field regardless of whether the molecules in the dielectric are polar or nonpolar.

With these ideas in mind, consider a slab of dielectric material placed between the plates of a capacitor so that it is in a uniform electric field \vec{E}_0 as shown in Figure 26.21b. The electric field due to the plates is directed to the right and polarizes the dielectric. The net effect on the dielectric is the formation of an *induced* positive surface charge density σ_{ind} on the right face and an equal-magnitude negative surface charge density $-\sigma_{\text{ind}}$ on the left face as shown in Figure 26.21c. Because we can model these surface charge distributions as being due to charged parallel plates, the induced surface charges on the dielectric give rise to an induced electric field \vec{E}_{ind} in the direction opposite the external field \vec{E}_0 . Therefore, the net electric field \vec{E} in the dielectric has a magnitude

$$E = E_0 - E_{\text{ind}} \quad (26.22)$$

In the parallel-plate capacitor shown in Figure 26.22, the external field E_0 is related to the charge density σ on the plates through the relationship $E_0 = \sigma/\epsilon_0$. The induced electric field in the dielectric is related to the induced charge density σ_{ind} through the relationship $E_{\text{ind}} = \sigma_{\text{ind}}/\epsilon_0$. Because $E = E_0/\kappa = \sigma/\kappa\epsilon_0$, substitution into Equation 26.22 gives

$$\begin{aligned} \frac{\sigma}{\kappa\epsilon_0} &= \frac{\sigma}{\epsilon_0} - \frac{\sigma_{\text{ind}}}{\epsilon_0} \\ \sigma_{\text{ind}} &= \left(\frac{\kappa - 1}{\kappa}\right)\sigma \end{aligned} \quad (26.23)$$

Because $\kappa > 1$, this expression shows that the charge density σ_{ind} induced on the dielectric is less than the charge density σ on the plates. For instance, if $\kappa = 3$, the induced charge density is two-thirds the charge density on the plates. If no dielectric is present, then $\kappa = 1$ and $\sigma_{\text{ind}} = 0$ as expected. If the dielectric is replaced by an electrical conductor for which $E = 0$, however, Equation 26.22 indicates that $E_0 = E_{\text{ind}}$, which corresponds to $\sigma_{\text{ind}} = \sigma$. That is, the surface charge induced on

The induced charge density σ_{ind} on the dielectric is *less* than the charge density σ on the plates.

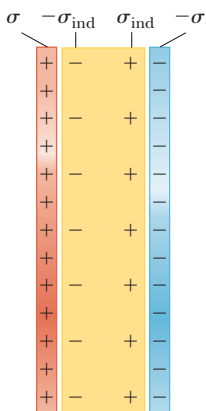

Figure 26.22 Induced charge on a dielectric placed between the plates of a charged capacitor.

the conductor is equal in magnitude but opposite in sign to that on the plates, resulting in a net electric field of zero in the conductor (see Fig. 24.16).

Example 26.7 Effect of a Metallic Slab

A parallel-plate capacitor has a plate separation d and plate area A . An uncharged metallic slab of thickness a is inserted midway between the plates.

(A) Find the capacitance of the device.

SOLUTION

Conceptualize Figure 26.23a shows the metallic slab between the plates of the capacitor. Any charge that appears on one plate of the capacitor must induce a charge of equal magnitude and opposite sign on the near side of the slab as shown in Figure 26.23a. Consequently, the net charge on the slab remains zero and the electric field inside the slab is zero.

Categorize The planes of charge on the metallic slab's upper and lower edges are identical to the distribution of charges on the plates of a capacitor. The metal between the slab's edges serves only to make an electrical connection between the edges. Therefore, we can model the edges of the slab as conducting planes and the bulk of the slab as a wire.

As a result, the capacitor in Figure 26.23a is equivalent to two capacitors in series, each having a plate separation $(d - a)/2$ as shown in Figure 26.23b.

Analyze Use Equation 26.3 and the rule for adding two capacitors in series (Eq. 26.10) to find the equivalent capacitance in Figure 26.23b:

$$\frac{1}{C} = \frac{1}{C_1} + \frac{1}{C_2} = \frac{1}{\frac{\epsilon_0 A}{(d-a)/2}} + \frac{1}{\frac{\epsilon_0 A}{(d-a)/2}}$$

$$C = \frac{\epsilon_0 A}{d-a}$$

(B) Show that the capacitance of the original capacitor is unaffected by the insertion of the metallic slab if the slab is infinitesimally thin.

SOLUTION

In the result for part (A), let $a \rightarrow 0$:

$$C = \lim_{a \rightarrow 0} \left(\frac{\epsilon_0 A}{d-a} \right) = \frac{\epsilon_0 A}{d}$$

Finalize The result of part (B) is the original capacitance before the slab is inserted, which tells us that we can insert an infinitesimally thin metallic sheet between the plates of a capacitor without affecting the capacitance. We use this fact in the next example.

WHAT IF? What if the metallic slab in part (A) is not midway between the plates? How would that affect the capacitance?

Answer Let's imagine moving the slab in Figure 26.23a upward so that the distance between the upper edge of the slab and the upper plate is b . Then, the distance between the lower edge of the slab and the lower plate is $d - b - a$. As in part (A), we find the total capacitance of the series combination:

$$\frac{1}{C} = \frac{1}{C_1} + \frac{1}{C_2} = \frac{1}{\epsilon_0 A / b} + \frac{1}{\epsilon_0 A / (d-b-a)}$$

$$= \frac{b}{\epsilon_0 A} + \frac{d-b-a}{\epsilon_0 A} = \frac{d-a}{\epsilon_0 A} \rightarrow C = \frac{\epsilon_0 A}{d-a}$$

which is the same result as found in part (A). The capacitance is independent of the value of b , so it does not matter where the slab is located. In Figure 26.23b, when the central structure is moved up or down, the decrease in plate separation of one capacitor is compensated by the increase in plate separation for the other.

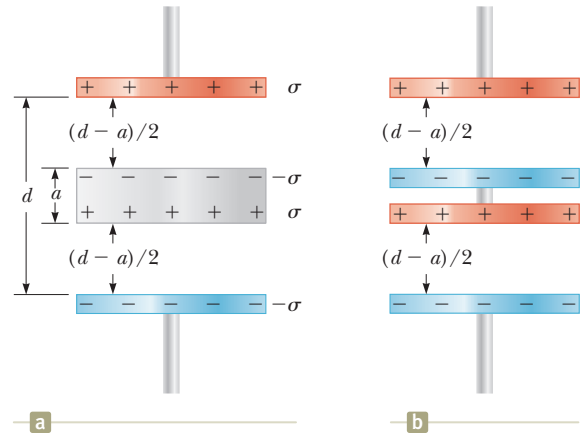

Figure 26.23 (Example 26.7) (a) A parallel-plate capacitor of plate separation d partially filled with a metallic slab of thickness a . (b) The equivalent circuit of the device in (a) consists of two capacitors in series, each having a plate separation $(d - a)/2$.

Example 26.8 A Partially Filled Capacitor

A parallel-plate capacitor with a plate separation d has a capacitance C_0 in the absence of a dielectric. What is the capacitance when a slab of dielectric material of dielectric constant κ and thickness fd is inserted between the plates (Fig. 26.24a), where f is a fraction between 0 and 1?

SOLUTION

Conceptualize In our previous discussions of dielectrics between the plates of a capacitor, the dielectric filled the volume between the plates. In this example, only part of the volume between the plates contains the dielectric material.

Categorize In Example 26.7, we found that an infinitesimally thin metallic sheet inserted between the plates of a capacitor does not affect the capacitance. Imagine sliding an infinitesimally thin metallic slab along the bottom face of the dielectric shown in Figure 26.24a. We can model this system as a series combination of two capacitors as shown in Figure 26.24b. One capacitor has a plate separation fd and is filled with a dielectric; the other has a plate separation $(1 - f)d$ and has air between its plates.

Analyze Evaluate the two capacitances in Figure 26.24b from Equation 26.15:

Find the equivalent capacitance C from Equation 26.10 for two capacitors combined in series:

Invert and substitute for the capacitance without the dielectric, $C_0 = \epsilon_0 A/d$:

Finalize Let's test this result for some known limits. If $f \rightarrow 0$, the dielectric should disappear. In this limit, $C \rightarrow C_0$, which is consistent with a capacitor with air between the plates. If $f \rightarrow 1$, the dielectric fills the volume between the plates. In this limit, $C \rightarrow \kappa C_0$, which is consistent with Equation 26.14.

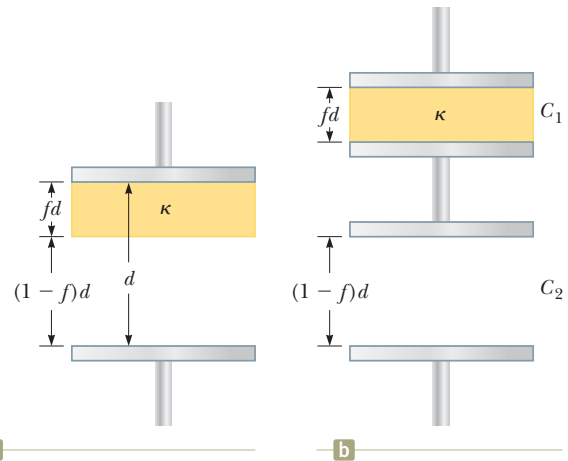

Figure 26.24 (Example 26.8) (a) A parallel-plate capacitor of plate separation d partially filled with a dielectric of thickness fd . (b) The equivalent circuit of the capacitor consists of two capacitors connected in series.

$$C_1 = \frac{\kappa \epsilon_0 A}{fd} \quad \text{and} \quad C_2 = \frac{\epsilon_0 A}{(1-f)d}$$

$$\frac{1}{C} = \frac{1}{C_1} + \frac{1}{C_2} = \frac{fd}{\kappa \epsilon_0 A} + \frac{(1-f)d}{\epsilon_0 A}$$

$$\frac{1}{C} = \frac{fd}{\kappa \epsilon_0 A} + \frac{\kappa(1-f)d}{\kappa \epsilon_0 A} = \frac{f + \kappa(1-f)}{\kappa} \frac{d}{\epsilon_0 A}$$

$$C = \frac{\kappa}{f + \kappa(1-f)} \frac{\epsilon_0 A}{d} = \frac{\kappa}{f + \kappa(1-f)} C_0$$

Summary

Definitions

A **capacitor** consists of two conductors carrying charges of equal magnitude and opposite sign. The **capacitance** C of any capacitor is the ratio of the charge Q on either conductor to the potential difference ΔV between them:

$$C \equiv \frac{Q}{\Delta V} \quad (26.1)$$

The capacitance depends only on the geometry of the conductors and not on an external source of charge or potential difference. The SI unit of capacitance is coulombs per volt, or the **farad** (F): $1 \text{ F} = 1 \text{ C/V}$.

The **electric dipole moment** \vec{p} of an electric dipole has a magnitude

$$p \equiv 2aq \quad (26.16)$$

where $2a$ is the distance between the charges q and $-q$. The direction of the electric dipole moment vector is from the negative charge toward the positive charge.

Concepts and Principles

If two or more capacitors are connected in parallel, the potential difference is the same across all capacitors. The equivalent capacitance of a **parallel combination** of capacitors is

$$C_{\text{eq}} = C_1 + C_2 + C_3 + \cdots \quad (26.8)$$

If two or more capacitors are connected in series, the charge is the same on all capacitors, and the equivalent capacitance of the **series combination** is given by

$$\frac{1}{C_{\text{eq}}} = \frac{1}{C_1} + \frac{1}{C_2} + \frac{1}{C_3} + \cdots \quad (26.10)$$

These two equations enable you to simplify many electric circuits by replacing multiple capacitors with a single equivalent capacitance.

When a dielectric material is inserted between the plates of a capacitor, the capacitance increases by a dimensionless factor κ , called the **dielectric constant**:

$$C = \kappa C_0 \quad (26.14)$$

where C_0 is the capacitance in the absence of the dielectric.

Energy is stored in a charged capacitor because the charging process is equivalent to the transfer of charges from one conductor at a lower electric potential to another conductor at a higher potential. The energy stored in a capacitor of capacitance C with charge Q and potential difference ΔV is

$$U_E = \frac{Q^2}{2C} = \frac{1}{2}Q\Delta V = \frac{1}{2}C(\Delta V)^2 \quad (26.11)$$

The torque acting on an electric dipole in a uniform electric field \vec{E} is

$$\vec{\tau} = \vec{p} \times \vec{E} \quad (26.18)$$

The potential energy of the system of an electric dipole in a uniform external electric field \vec{E} is

$$U_E = -\vec{p} \cdot \vec{E} \quad (26.20)$$

Objective Questions

1. denotes answer available in *Student Solutions Manual/Study Guide*

- A fully charged parallel-plate capacitor remains connected to a battery while you slide a dielectric between the plates. Do the following quantities (a) increase, (b) decrease, or (c) stay the same? (i) C (ii) Q (iii) ΔV (iv) the energy stored in the capacitor
- By what factor is the capacitance of a metal sphere multiplied if its volume is tripled? (a) 3 (b) $3^{1/3}$ (c) 1 (d) $3^{-1/3}$ (e) $\frac{1}{3}$
- An electronics technician wishes to construct a parallel-plate capacitor using rutile ($\kappa = 100$) as the dielectric. The area of the plates is 1.00 cm^2 . What is the capacitance if the rutile thickness is 1.00 mm ? (a) 88.5 pF (b) 177 pF (c) $8.85 \mu\text{F}$ (d) $100 \mu\text{F}$ (e) $35.4 \mu\text{F}$
- A parallel-plate capacitor is connected to a battery. What happens to the stored energy if the plate separation is doubled while the capacitor remains connected to the battery? (a) It remains the same. (b) It is doubled. (c) It decreases by a factor of 2. (d) It decreases by a factor of 4. (e) It increases by a factor of 4.
- If three unequal capacitors, initially uncharged, are connected in series across a battery, which of the following statements is true? (a) The equivalent capacitance is greater than any of the individual capacitances. (b) The largest voltage appears across the smallest capacitance. (c) The largest voltage appears across the largest capacitance. (d) The capacitor with the largest capacitance has the greatest charge. (e) The capacitor with the smallest capacitance has the smallest charge.
- Assume a device is designed to obtain a large potential difference by first charging a bank of capacitors connected in parallel and then activating a switch arrangement that in effect disconnects the capacitors from the charging source and from each other and reconnects them all in a series arrangement. The group of charged capacitors is then discharged in series. What is the maximum potential difference that can be obtained in this manner by using ten $500\text{-}\mu\text{F}$ capacitors and an 800-V charging source? (a) 500 V (b) 8.00 kV (c) 400 kV (d) 800 V (e) 0
- (i) What happens to the magnitude of the charge on each plate of a capacitor if the potential difference between the conductors is doubled? (a) It becomes four times larger. (b) It becomes two times larger. (c) It is unchanged. (d) It becomes one-half as large. (e) It becomes one-fourth as large. (ii) If the potential difference across a capacitor is doubled, what happens to the energy stored? Choose from the same possibilities as in part (i).
- A capacitor with very large capacitance is in series with another capacitor with very small capacitance. What is the equivalent capacitance of the combination? (a) slightly greater than the capacitance of the large capacitor (b) slightly less than the capacitance of the large capacitor (c) slightly greater than the capacitance of the small capacitor (d) slightly less than the capacitance of the small capacitor

9. A parallel-plate capacitor filled with air carries a charge Q . The battery is disconnected, and a slab of material with dielectric constant $\kappa = 2$ is inserted between the plates. Which of the following statements is true? (a) The voltage across the capacitor decreases by a factor of 2. (b) The voltage across the capacitor is doubled. (c) The charge on the plates is doubled. (d) The charge on the plates decreases by a factor of 2. (e) The electric field is doubled.
10. (i) A battery is attached to several different capacitors connected in parallel. Which of the following statements is true? (a) All capacitors have the same charge, and the equivalent capacitance is greater than the capacitance of any of the capacitors in the group. (b) The capacitor with the largest capacitance carries the smallest charge. (c) The potential difference across each capacitor is the same, and the equivalent capacitance is greater than any of the capacitors in the group. (d) The capacitor with the smallest capacitance carries the largest charge. (e) The potential differences across the capacitors are the same only if the capacitances are the same. (ii) The capacitors are reconnected in series, and the combination is again connected to the battery. From the same choices, choose the one that is true.
11. A parallel-plate capacitor is charged and then is disconnected from the battery. By what factor does the stored energy change when the plate separation is then doubled? (a) It becomes four times larger. (b) It becomes two times larger. (c) It stays the same. (d) It becomes one-half as large. (e) It becomes one-fourth as large.
12. (i) Rank the following five capacitors from greatest to smallest capacitance, noting any cases of equality. (a) a $20\text{-}\mu\text{F}$ capacitor with a 4-V potential difference between its plates (b) a $30\text{-}\mu\text{F}$ capacitor with charges of magnitude $90\ \mu\text{C}$ on each plate (c) a capacitor with charges of magnitude $80\ \mu\text{C}$ on its plates, differing by 2 V in potential, (d) a $10\text{-}\mu\text{F}$ capacitor storing energy $125\ \mu\text{J}$ (e) a capacitor storing energy $250\ \mu\text{J}$ with a 10-V potential difference (ii) Rank the same capacitors in part (i) from largest to smallest according to the potential difference between the plates. (iii) Rank the capacitors in part (i) in the order of the magnitudes of the charges on their plates. (iv) Rank the capacitors in part (i) in the order of the energy they store.
13. True or False? (a) From the definition of capacitance $C = Q/\Delta V$, it follows that an uncharged capacitor has a capacitance of zero. (b) As described by the definition of capacitance, the potential difference across an uncharged capacitor is zero.
14. You charge a parallel-plate capacitor, remove it from the battery, and prevent the wires connected to the plates from touching each other. When you increase the plate separation, do the following quantities (a) increase, (b) decrease, or (c) stay the same? (i) C (ii) Q (iii) E between the plates (iv) ΔV

Conceptual Questions

1. denotes answer available in *Student Solutions Manual/Study Guide*

- (a) Why is it dangerous to touch the terminals of a high-voltage capacitor even after the voltage source that charged the capacitor is disconnected from the capacitor? (b) What can be done to make the capacitor safe to handle after the voltage source has been removed?
- Assume you want to increase the maximum operating voltage of a parallel-plate capacitor. Describe how you can do that with a fixed plate separation.
- 3.** If you were asked to design a capacitor in which small size and large capacitance were required, what would be the two most important factors in your design?
- Explain why a dielectric increases the maximum operating voltage of a capacitor even though the physical size of the capacitor doesn't change.
- Explain why the work needed to move a particle with charge Q through a potential difference ΔV is $W = Q\Delta V$, whereas the energy stored in a charged capacitor is $U_E = \frac{1}{2}Q\Delta V$. Where does the factor $\frac{1}{2}$ come from?
- An air-filled capacitor is charged, then disconnected from the power supply, and finally connected to a voltmeter. Explain how and why the potential difference changes when a dielectric is inserted between the plates of the capacitor.
- The sum of the charges on both plates of a capacitor is zero. What does a capacitor store?
- Because the charges on the plates of a parallel-plate capacitor are opposite in sign, they attract each other. Hence, it would take positive work to increase the plate separation. What type of energy in the system changes due to the external work done in this process?

Problems



The problems found in this chapter may be assigned online in Enhanced WebAssign

1. straightforward; 2. intermediate; 3. challenging

1. full solution available in the *Student Solutions Manual/Study Guide*

AMT Analysis Model tutorial available in Enhanced WebAssign

GP Guided Problem

M Master It tutorial available in Enhanced WebAssign

W Watch It video solution available in Enhanced WebAssign

Section 26.1 Definition of Capacitance

- (a) When a battery is connected to the plates of a $3.00\text{-}\mu\text{F}$ capacitor, it stores a charge of $27.0\ \mu\text{C}$. What is the voltage of the battery? (b) If the same capacitor is connected to another battery and $36.0\ \mu\text{C}$ of charge is stored on the capacitor, what is the voltage of the battery?
- Two conductors having net charges of $+10.0\ \mu\text{C}$ and $-10.0\ \mu\text{C}$ have a potential difference of $10.0\ \text{V}$ between them. (a) Determine the capacitance of the system. (b) What is the potential difference between the two conductors if the charges on each are increased to $+100\ \mu\text{C}$ and $-100\ \mu\text{C}$?
- (a) How much charge is on each plate of a $4.00\text{-}\mu\text{F}$ capacitor when it is connected to a 12.0-V battery? (b) If this same capacitor is connected to a 1.50-V battery, what charge is stored?

Section 26.2 Calculating Capacitance

- An air-filled spherical capacitor is constructed with inner- and outer-shell radii of $7.00\ \text{cm}$ and $14.0\ \text{cm}$, respectively. (a) Calculate the capacitance of the device. (b) What potential difference between the spheres results in a $4.00\text{-}\mu\text{C}$ charge on the capacitor?
- A 50.0-m length of coaxial cable has an inner conductor that has a diameter of $2.58\ \text{mm}$ and carries a charge of $8.10\ \mu\text{C}$. The surrounding conductor has an inner diameter of $7.27\ \text{mm}$ and a charge of $-8.10\ \mu\text{C}$. Assume the region between the conductors is air. (a) What is the capacitance of this cable? (b) What is the potential difference between the two conductors?
- (a) Regarding the Earth and a cloud layer $800\ \text{m}$ above the Earth as the “plates” of a capacitor, calculate the capacitance of the Earth–cloud layer system. Assume the cloud layer has an area of $1.00\ \text{km}^2$ and the air between the cloud and the ground is pure and dry. Assume charge builds up on the cloud and on the ground until a uniform electric field of $3.00 \times 10^6\ \text{N/C}$ throughout the space between them makes the air break down and conduct electricity as a lightning bolt. (b) What is the maximum charge the cloud can hold?
- When a potential difference of $150\ \text{V}$ is applied to the plates of a parallel-plate capacitor, the plates carry a surface charge density of $30.0\ \text{nC/cm}^2$. What is the spacing between the plates?
- An air-filled parallel-plate capacitor has plates of area $2.30\ \text{cm}^2$ separated by $1.50\ \text{mm}$. (a) Find the value of its capacitance. The capacitor is connected to a 12.0-V battery. (b) What is the charge on the capacitor? (c) What is the magnitude of the uniform electric field between the plates?
- An air-filled capacitor consists of two parallel plates, each with an area of $7.60\ \text{cm}^2$, separated by a distance of $1.80\ \text{mm}$. A 20.0-V potential difference is applied to these plates. Calculate (a) the electric field between the plates, (b) the surface charge density, (c) the capacitance, and (d) the charge on each plate.

- A variable air capacitor used in a radio tuning circuit is made of N semicircular plates, each of radius R and positioned a distance d from its neighbors, to which it is electrically connected. As shown in Figure P26.10, a second identical set of plates is enmeshed with the first set. Each plate in the second set is halfway between two plates of the first set. The second set can rotate as a unit. Determine the capacitance as a function of the angle of rotation θ , where $\theta = 0$ corresponds to the maximum capacitance.

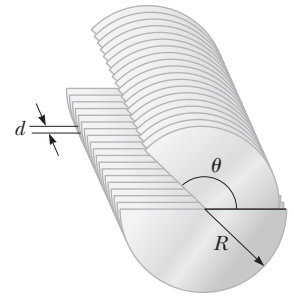

Figure P26.10

- An isolated, charged conducting sphere of radius $12.0\ \text{cm}$ creates an electric field of $4.90 \times 10^4\ \text{N/C}$ at a distance $21.0\ \text{cm}$ from its center. (a) What is its surface charge density? (b) What is its capacitance?
- Review.** A small object of mass m carries a charge q and is suspended by a thread between the vertical plates of a parallel-plate capacitor. The plate separation is d . If the thread makes an angle θ with the vertical, what is the potential difference between the plates?

Section 26.3 Combinations of Capacitors

- Two capacitors, $C_1 = 5.00\ \mu\text{F}$ and $C_2 = 12.0\ \mu\text{F}$, are connected in parallel, and the resulting combination is connected to a 9.00-V battery. Find (a) the equivalent capacitance of the combination, (b) the potential difference across each capacitor, and (c) the charge stored on each capacitor.
- What If?** The two capacitors of Problem 13 ($C_1 = 5.00\ \mu\text{F}$ and $C_2 = 12.0\ \mu\text{F}$) are now connected in series and to a 9.00-V battery. Find (a) the equivalent capacitance of the combination, (b) the potential difference across each capacitor, and (c) the charge on each capacitor.
- Find the equivalent capacitance of a $4.20\text{-}\mu\text{F}$ capacitor and an $8.50\text{-}\mu\text{F}$ capacitor when they are connected (a) in series and (b) in parallel.
- Given a $2.50\text{-}\mu\text{F}$ capacitor, a $6.25\text{-}\mu\text{F}$ capacitor, and a 6.00-V battery, find the charge on each capacitor if you connect them (a) in series across the battery and (b) in parallel across the battery.
- According to its design specification, the timer circuit delaying the closing of an elevator door is to have a capacitance of $32.0\ \mu\text{F}$ between two points A and B . When one circuit is being constructed, the inexpensive but durable capacitor installed between these two points is found to have capacitance $34.8\ \mu\text{F}$. To meet the specification, one additional capacitor can be placed between the two points. (a) Should it be in series or in parallel with the $34.8\text{-}\mu\text{F}$ capacitor? (b) What should be its capacitance? (c) **What If?** The next circuit comes down the assembly line with capacitance $29.8\ \mu\text{F}$ between A and B . To meet the specification, what additional capacitor should be installed in series or in parallel in that circuit?

18. Why is the following situation impossible? A technician is testing a circuit that contains a capacitance C . He realizes that a better design for the circuit would include a capacitance $\frac{7}{3}C$ rather than C . He has three additional capacitors, each with capacitance C . By combining these additional capacitors in a certain combination that is then placed in parallel with the original capacitor, he achieves the desired capacitance.

19. For the system of four capacitors shown in Figure P26.19, find (a) the equivalent capacitance of the system, (b) the charge on each capacitor, and (c) the potential difference across each capacitor.

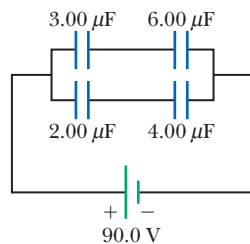

Figure P26.19

Problems 19 and 56.

20. Three capacitors are connected to a battery as shown in Figure P26.20. Their capacitances are $C_1 = 3C$, $C_2 = C$, and $C_3 = 5C$. (a) What is the equivalent capacitance of this set of capacitors? (b) State the ranking of the capacitors according to the charge they store from largest to smallest. (c) Rank the capacitors according to the potential differences across them from largest to smallest. (d) **What If?** Assume C_3 is increased. Explain what happens to the charge stored by each capacitor.

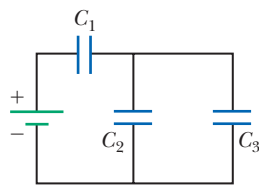

Figure P26.20

21. **M** A group of identical capacitors is connected first in series and then in parallel. The combined capacitance in parallel is 100 times larger than for the series connection. How many capacitors are in the group?

22. **W** (a) Find the equivalent capacitance between points a and b for the group of capacitors connected as shown in Figure P26.22. Take $C_1 = 5.00 \mu\text{F}$, $C_2 = 10.0 \mu\text{F}$, and $C_3 = 2.00 \mu\text{F}$. (b) What charge is stored on C_3 if the potential difference between points a and b is 60.0 V ?

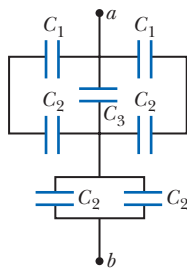

Figure P26.22

23. **M** Four capacitors are connected as shown in Figure P26.23. (a) Find the equivalent capacitance between points a and b . (b) Calculate the charge on each capacitor, taking $\Delta V_{ab} = 15.0 \text{ V}$.

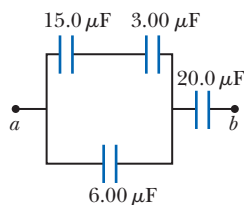

Figure P26.23

24. **M** Consider the circuit shown in Figure P26.24, where $C_1 = 6.00 \mu\text{F}$, $C_2 = 3.00 \mu\text{F}$, and $\Delta V = 20.0 \text{ V}$. Capacitor C_1

is first charged by closing switch S_1 . Switch S_1 is then opened, and the charged capacitor is connected to the uncharged capacitor by closing S_2 . Calculate (a) the initial charge acquired by C_1 and (b) the final charge on each capacitor.

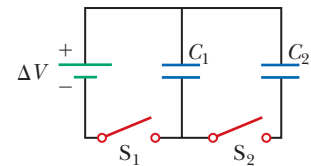

Figure P26.24

25. Find the equivalent capacitance between points a and b in the combination of capacitors shown in Figure P26.25.

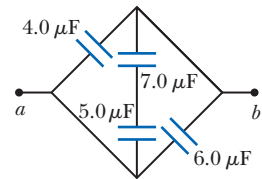

Figure P26.25

26. Find (a) the equivalent capacitance of the capacitors in Figure P26.26, (b) the charge on each capacitor, and (c) the potential difference across each capacitor.

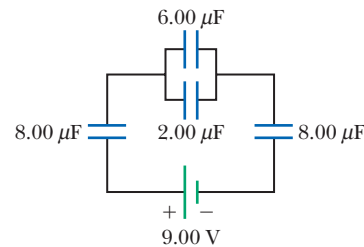

Figure P26.26

27. Two capacitors give an equivalent capacitance of 9.00 pF when connected in parallel and an equivalent capacitance of 2.00 pF when connected in series. What is the capacitance of each capacitor?

28. Two capacitors give an equivalent capacitance of C_p when connected in parallel and an equivalent capacitance of C_s when connected in series. What is the capacitance of each capacitor?

29. Consider three capacitors C_1 , C_2 , and C_3 and a battery. If only C_1 is connected to the battery, the charge on C_1 is $30.8 \mu\text{C}$. Now C_1 is disconnected, discharged, and connected in series with C_2 . When the series combination of C_2 and C_1 is connected across the battery, the charge on C_1 is $23.1 \mu\text{C}$. The circuit is disconnected, and both capacitors are discharged. Next, C_3 , C_1 , and the battery are connected in series, resulting in a charge on C_1 of $25.2 \mu\text{C}$. If, after being disconnected and discharged, C_1 , C_2 , and C_3 are connected in series with one another and with the battery, what is the charge on C_1 ?

Section 26.4 Energy Stored in a Charged Capacitor

30. The immediate cause of many deaths is ventricular fibrillation, which is an uncoordinated quivering of the heart. An electric shock to the chest can cause momentary paralysis of the heart muscle, after which the heart sometimes resumes its proper beating. One type of *defibrillator* (chapter-opening photo, page 777) applies a strong electric shock to the chest over a time interval of a few milliseconds. This device contains a

- capacitor of several microfarads, charged to several thousand volts. Electrodes called paddles are held against the chest on both sides of the heart, and the capacitor is discharged through the patient's chest. Assume an energy of 300 J is to be delivered from a 30.0- μF capacitor. To what potential difference must it be charged?
31. A 12.0-V battery is connected to a capacitor, resulting in 54.0 μC of charge stored on the capacitor. How much energy is stored in the capacitor?
32. (a) A 3.00- μF capacitor is connected to a 12.0-V battery. **W** How much energy is stored in the capacitor? (b) Had the capacitor been connected to a 6.00-V battery, how much energy would have been stored?
33. As a person moves about in a dry environment, electric charge accumulates on the person's body. Once it is at high voltage, either positive or negative, the body can discharge via sparks and shocks. Consider a human body isolated from ground, with the typical capacitance 150 pF. (a) What charge on the body will produce a potential of 10.0 kV? (b) Sensitive electronic devices can be destroyed by electrostatic discharge from a person. A particular device can be destroyed by a discharge releasing an energy of 250 μJ . To what voltage on the body does this situation correspond?
34. Two capacitors, $C_1 = 18.0 \mu\text{F}$ and $C_2 = 36.0 \mu\text{F}$, are connected in series, and a 12.0-V battery is connected across the two capacitors. Find (a) the equivalent capacitance and (b) the energy stored in this equivalent capacitance. (c) Find the energy stored in each individual capacitor. (d) Show that the sum of these two energies is the same as the energy found in part (b). (e) Will this equality always be true, or does it depend on the number of capacitors and their capacitances? (f) If the same capacitors were connected in parallel, what potential difference would be required across them so that the combination stores the same energy as in part (a)? (g) Which capacitor stores more energy in this situation, C_1 or C_2 ?
35. Two identical parallel-plate capacitors, each with capacitance 10.0 μF , are charged to potential difference 50.0 V and then disconnected from the battery. They are then connected to each other in parallel with plates of like sign connected. Finally, the plate separation in one of the capacitors is doubled. (a) Find the total energy of the system of two capacitors *before* the plate separation is doubled. (b) Find the potential difference across each capacitor *after* the plate separation is doubled. (c) Find the total energy of the system *after* the plate separation is doubled. (d) Reconcile the difference in the answers to parts (a) and (c) with the law of conservation of energy.
36. Two identical parallel-plate capacitors, each with capacitance C , are charged to potential difference ΔV and then disconnected from the battery. They are then connected to each other in parallel with plates of like sign connected. Finally, the plate separation in one of the capacitors is doubled. (a) Find the total energy of the system of two capacitors *before* the plate separation is doubled. (b) Find the potential difference across each capacitor *after* the plate separation is doubled. (c) Find the total energy of the system *after* the plate separation is doubled. (d) Reconcile the difference in the answers to parts (a) and (c) with the law of conservation of energy.
37. Two capacitors, $C_1 = 25.0 \mu\text{F}$ and $C_2 = 5.00 \mu\text{F}$, are connected in parallel and charged with a 100-V power supply. (a) Draw a circuit diagram and (b) calculate the total energy stored in the two capacitors. (c) **What If?** What potential difference would be required across the same two capacitors connected in series for the combination to store the same amount of energy as in part (b)? (d) Draw a circuit diagram of the circuit described in part (c).
- 38.** A parallel-plate capacitor has a charge Q and plates of area A . What force acts on one plate to attract it toward the other plate? Because the electric field between the plates is $E = Q/A\epsilon_0$, you might think the force is $F = QE = Q^2/A\epsilon_0$. This conclusion is wrong because the field E includes contributions from both plates, and the field created by the positive plate cannot exert any force on the positive plate. Show that the force exerted on each plate is actually $F = Q^2/2A\epsilon_0$. *Suggestion:* Let $C = \epsilon_0 A/x$ for an arbitrary plate separation x and note that the work done in separating the two charged plates is $W = \int F dx$.
- 39. Review.** A storm cloud and the ground represent the plates of a capacitor. During a storm, the capacitor has a potential difference of $1.00 \times 10^8 \text{ V}$ between its plates and a charge of 50.0 C. A lightning strike delivers 1.00% of the energy of the capacitor to a tree on the ground. How much sap in the tree can be boiled away? Model the sap as water initially at 30.0°C. Water has a specific heat of 4 186 J/kg \cdot °C, a boiling point of 100°C, and a latent heat of vaporization of $2.26 \times 10^6 \text{ J/kg}$.
- 40. GP** Consider two conducting spheres with radii R_1 and R_2 separated by a distance much greater than either radius. A total charge Q is shared between the spheres. We wish to show that when the electric potential energy of the system has a minimum value, the potential difference between the spheres is zero. The total charge Q is equal to $q_1 + q_2$, where q_1 represents the charge on the first sphere and q_2 the charge on the second. Because the spheres are very far apart, you can assume the charge of each is uniformly distributed over its surface. (a) Show that the energy associated with a single conducting sphere of radius R and charge q surrounded by a vacuum is $U = k_e q^2/2R$. (b) Find the total energy of the system of two spheres in terms of q_1 , the total charge Q , and the radii R_1 and R_2 . (c) To minimize the energy, differentiate the result to part (b) with respect to q_1 and set the derivative equal to zero. Solve for q_1 in terms of Q and the radii. (d) From the result to part (c), find the charge q_2 . (e) Find the potential of each sphere. (f) What is the potential difference between the spheres?
- 41. Review.** The circuit in Figure P26.41 (page 804) consists of two identical, parallel metal plates connected to identical metal springs, a switch, and a 100-V battery.

With the switch open, the plates are uncharged, are separated by a distance $d = 8.00$ mm, and have a capacitance $C = 2.00$ μF . When the switch is closed, the distance between the plates decreases by a factor of 0.500. (a) How much charge collects on each plate? (b) What is the spring constant for each spring?

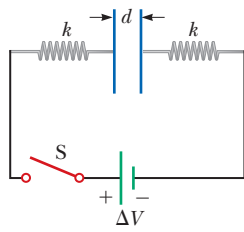

Figure P26.41

Section 26.5 Capacitors with Dielectrics

42. A supermarket sells rolls of aluminum foil, plastic wrap, and waxed paper. (a) Describe a capacitor made from such materials. Compute order-of-magnitude estimates for (b) its capacitance and (c) its breakdown voltage.
43. (a) How much charge can be placed on a capacitor with **W** air between the plates before it breaks down if the area of each plate is 5.00 cm^2 ? (b) **What If?** Find the maximum charge if polystyrene is used between the plates instead of air.
44. The voltage across an air-filled parallel-plate capacitor is measured to be 85.0 V. When a dielectric is inserted and completely fills the space between the plates as in Figure P26.44, the voltage drops to 25.0 V. (a) What is the dielectric constant of the inserted material? (b) Can you identify the dielectric? If so, what is it? (c) If the dielectric does not completely fill the space between the plates, what could you conclude about the voltage across the plates?

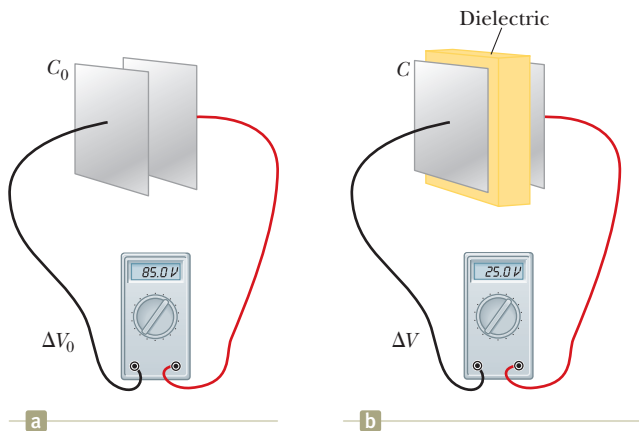

Figure P26.44

45. Determine (a) the capacitance and (b) the maximum potential difference that can be applied to a Teflon-filled parallel-plate capacitor having a plate area of 1.75 cm^2 and a plate separation of 0.0400 mm.
46. **W** A commercial capacitor is to be constructed as shown in Figure P26.46. This particular capacitor is made from two strips of aluminum foil separated by a strip of paraffin-coated paper. Each strip of foil and paper is 7.00 cm wide. The foil is 0.00400 mm thick, and the paper is 0.0250 mm thick and has a dielectric constant of 3.70 . What length should the strips have if a capaci-

tance of 9.50×10^{-8} F is desired before the capacitor is rolled up? (Adding a second strip of paper and rolling the capacitor would effectively double its capacitance by allowing charge storage on both sides of each strip of foil.)

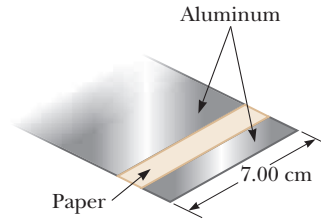

Figure P26.46

47. A parallel-plate capacitor in air has a plate separation of 1.50 cm and a plate area of 25.0 cm^2 . The plates are charged to a potential difference of 250 V and disconnected from the source. The capacitor is then immersed in distilled water. Assume the liquid is an insulator. Determine (a) the charge on the plates before and after immersion, (b) the capacitance and potential difference after immersion, and (c) the change in energy of the capacitor.
48. Each capacitor in the combination shown in Figure P26.48 has a breakdown voltage of 15.0 V. What is the breakdown voltage of the combination?

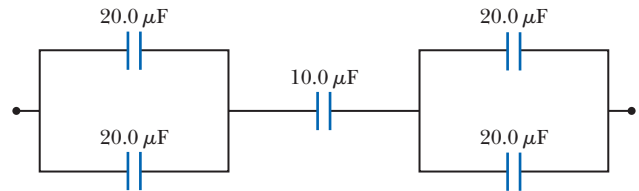

Figure P26.48

49. **AMT** A 2.00 -nF parallel-plate capacitor is charged to an initial potential difference $\Delta V_i = 100$ V and is then isolated. The dielectric material between the plates is mica, with a dielectric constant of 5.00 . (a) How much work is required to withdraw the mica sheet? (b) What is the potential difference across the capacitor after the mica is withdrawn?

Section 26.6 Electric Dipole in an Electric Field

50. **M** A small, rigid object carries positive and negative 3.50 -nC charges. It is oriented so that the positive charge has coordinates $(-1.20$ mm, 1.10 mm) and the negative charge is at the point $(1.40$ mm, -1.30 mm). (a) Find the electric dipole moment of the object. The object is placed in an electric field $\vec{E} = (7.80 \times 10^3 \hat{i} - 4.90 \times 10^3 \hat{j})$ N/C. (b) Find the torque acting on the object. (c) Find the potential energy of the object-field system when the object is in this orientation. (d) Assuming the orientation of the object can change, find the difference between the maximum and minimum potential energies of the system.
51. **AMT** An infinite line of positive charge lies along the y axis, with charge density $\lambda = 2.00$ $\mu\text{C}/\text{m}$. A dipole is placed

with its center along the x axis at $x = 25.0$ cm. The dipole consists of two charges $\pm 10.0 \mu\text{C}$ separated by 2.00 cm. The axis of the dipole makes an angle of 35.0° with the x axis, and the positive charge is farther from the line of charge than the negative charge. Find the net force exerted on the dipole.

52. A small object with electric dipole moment \vec{p} is placed in a nonuniform electric field $\vec{E} = E(x)\hat{i}$. That is, the field is in the x direction, and its magnitude depends only on the coordinate x . Let θ represent the angle between the dipole moment and the x direction. Prove that the net force on the dipole is

$$F = p \left(\frac{dE}{dx} \right) \cos \theta$$

acting in the direction of increasing field.

Section 26.7 An Atomic Description of Dielectrics

53. The general form of Gauss's law describes how a charge creates an electric field in a material, as well as in vacuum:

$$\int \vec{E} \cdot d\vec{A} = \frac{q_{\text{in}}}{\epsilon}$$

where $\epsilon = \kappa\epsilon_0$ is the permittivity of the material. (a) A sheet with charge Q uniformly distributed over its area A is surrounded by a dielectric. Show that the sheet creates a uniform electric field at nearby points with magnitude $E = Q/2A\epsilon$. (b) Two large sheets of area A , carrying opposite charges of equal magnitude Q , are a small distance d apart. Show that they create uniform electric field in the space between them with magnitude $E = Q/A\epsilon$. (c) Assume the negative plate is at zero potential. Show that the positive plate is at potential $Qd/A\epsilon$. (d) Show that the capacitance of the pair of plates is given by $C = A\epsilon/d = \kappa A\epsilon_0/d$.

Additional Problems

54. Find the equivalent capacitance of the group of capacitors shown in Figure P26.54.

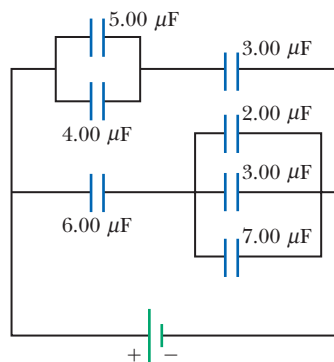

Figure P26.54

55. Four parallel metal plates P_1 , P_2 , P_3 , and P_4 , each of area 7.50 cm^2 , are separated successively by a distance $d = 1.19 \text{ mm}$ as shown in Figure P26.55. Plate P_1 is connected to the negative terminal of a battery, and P_2 is connected to the positive terminal. The

battery maintains a potential difference of 12.0 V . (a) If P_3 is connected to the negative terminal, what is the capacitance of the three-plate system $P_1P_2P_3$? (b) What is the charge on P_3 ? (c) If P_4 is now connected to the positive terminal, what is the capacitance of the four-plate system $P_1P_2P_3P_4$? (d) What is the charge on P_4 ?

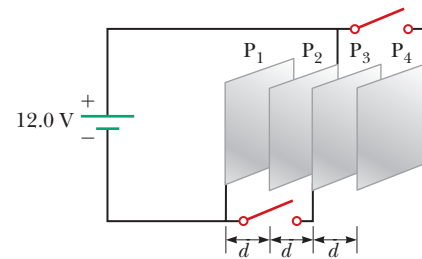

Figure P26.55

56. For the system of four capacitors shown in Figure P26.19, find (a) the total energy stored in the system and (b) the energy stored by each capacitor. (c) Compare the sum of the answers in part (b) with your result to part (a) and explain your observation.
57. A uniform electric field $E = 3\,000 \text{ V/m}$ exists within a certain region. What volume of space contains an energy equal to $1.00 \times 10^{-7} \text{ J}$? Express your answer in cubic meters and in liters.
58. Two large, parallel metal plates, each of area A , are oriented horizontally and separated by a distance $3d$. A grounded conducting wire joins them, and initially each plate carries no charge. Now a third identical plate carrying charge Q is inserted between the two plates, parallel to them and located a distance d from the upper plate as shown in Figure P26.58. (a) What induced charge appears on each of the two original plates? (b) What potential difference appears between the middle plate and each of the other plates?

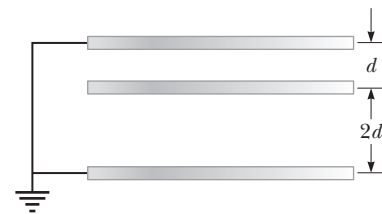

Figure P26.58

59. A parallel-plate capacitor is constructed using a dielectric material whose dielectric constant is 3.00 and whose dielectric strength is $2.00 \times 10^8 \text{ V/m}$. The desired capacitance is $0.250 \mu\text{F}$, and the capacitor must withstand a maximum potential difference of 4.00 kV . Find the minimum area of the capacitor plates.
60. Why is the following situation impossible? A $10.0\text{-}\mu\text{F}$ capacitor has plates with vacuum between them. The capacitor is charged so that it stores 0.050 J of energy. A particle with charge $-3.00 \mu\text{C}$ is fired from the positive plate toward the negative plate with an initial kinetic energy equal to $1.00 \times 10^{-4} \text{ J}$. The particle arrives at the negative plate with a reduced kinetic energy.

61. A model of a red blood cell portrays the cell as a capacitor with two spherical plates. It is a positively charged conducting liquid sphere of area A , separated by an insulating membrane of thickness t from the surrounding negatively charged conducting fluid. Tiny electrodes introduced into the cell show a potential difference of 100 mV across the membrane. Take the membrane's thickness as 100 nm and its dielectric constant as 5.00. (a) Assume that a typical red blood cell has a mass of 1.00×10^{-12} kg and density 1.100 kg/m³. Calculate its volume and its surface area. (b) Find the capacitance of the cell. (c) Calculate the charge on the surfaces of the membrane. How many electronic charges does this charge represent?

62. A parallel-plate capacitor with vacuum between its horizontal plates has a capacitance of $25.0 \mu\text{F}$. A nonconducting liquid with dielectric constant 6.50 is poured into the space between the plates, filling up a fraction f of its volume. (a) Find the new capacitance as a function of f . (b) What should you expect the capacitance to be when $f = 0$? Does your expression from part (a) agree with your answer? (c) What capacitance should you expect when $f = 1$? Does the expression from part (a) agree with your answer?

63. A $10.0\text{-}\mu\text{F}$ capacitor is charged to 15.0 V. It is next connected in series with an uncharged $5.00\text{-}\mu\text{F}$ capacitor. The series combination is finally connected across a 50.0-V battery as diagrammed in Figure P26.63. Find the new potential differences across the $5.00\text{-}\mu\text{F}$ and $10.0\text{-}\mu\text{F}$ capacitors after the switch is thrown closed.

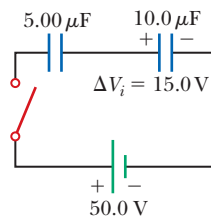

Figure P26.63

64. Assume that the internal diameter of the Geiger-Mueller tube described in Problem 68 in Chapter 25 is 2.50 cm and that the wire along the axis has a diameter of 0.200 mm. The dielectric strength of the gas between the central wire and the cylinder is 1.20×10^6 V/m. Use the result of that problem to calculate the maximum potential difference that can be applied between the wire and the cylinder before breakdown occurs in the gas.

65. Two square plates of sides ℓ are placed parallel to each other with separation d as suggested in Figure P26.65. You may assume d is much less than ℓ . The plates carry uniformly distributed static charges $+Q_0$ and $-Q_0$. A block of metal has width ℓ , length ℓ , and thickness slightly less than d . It is inserted a distance x into the space between the plates. The charges on the plates remain uniformly distributed as the block slides in. In a static situation, a metal prevents an electric field from penetrating inside it. The metal can be thought of as a perfect dielectric, with $\kappa \rightarrow \infty$. (a) Calculate the stored energy in the system as a function of x . (b) Find the direction and magnitude of the force that acts on the metallic block. (c) The area of the advancing front face of the block is essentially equal to ℓd . Considering the force on the block as acting on this face, find the stress (force per area)

on it. (d) Express the energy density in the electric field between the charged plates in terms of Q_0 , ℓ , d , and ϵ_0 . (e) Explain how the answers to parts (c) and (d) compare with each other.

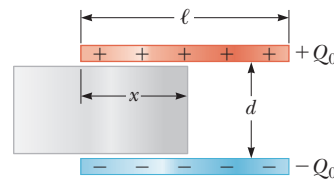

Figure P26.65

66. (a) Two spheres have radii a and b , and their centers are a distance d apart. Show that the capacitance of this system is

$$C = \frac{4\pi\epsilon_0}{\frac{1}{a} + \frac{1}{b} - \frac{2}{d}}$$

provided d is large compared with a and b . *Suggestion:* Because the spheres are far apart, assume the potential of each equals the sum of the potentials due to each sphere. (b) Show that as d approaches infinity, the above result reduces to that of two spherical capacitors in series.

67. A capacitor of unknown capacitance has been charged to a potential difference of 100 V and then disconnected from the battery. When the charged capacitor is then connected in parallel to an uncharged $10.0\text{-}\mu\text{F}$ capacitor, the potential difference across the combination is 30.0 V. Calculate the unknown capacitance.

68. A parallel-plate capacitor of plate separation d is charged to a potential difference ΔV_0 . A dielectric slab of thickness d and dielectric constant κ is introduced between the plates while the battery remains connected to the plates. (a) Show that the ratio of energy stored after the dielectric is introduced to the energy stored in the empty capacitor is $U/U_0 = \kappa$. (b) Give a physical explanation for this increase in stored energy. (c) What happens to the charge on the capacitor? *Note:* This situation is not the same as in Example 26.5, in which the battery was removed from the circuit before the dielectric was introduced.

69. Capacitors $C_1 = 6.00 \mu\text{F}$ and $C_2 = 2.00 \mu\text{F}$ are charged as a parallel combination across a 250-V battery. The capacitors are disconnected from the battery and from each other. They are then connected positive plate to negative plate and negative plate to positive plate. Calculate the resulting charge on each capacitor.

70. Example 26.1 explored a cylindrical capacitor of length ℓ with radii a and b for the two conductors. In the What If? section of that example, it was claimed that increasing ℓ by 10% is more effective in terms of increasing the capacitance than increasing a by 10% if $b > 2.85a$. Verify this claim mathematically.

71. To repair a power supply for a stereo amplifier, an electronics technician needs a $100\text{-}\mu\text{F}$ capacitor capable of withstanding a potential difference of 90 V between the

plates. The immediately available supply is a box of five $100\text{-}\mu\text{F}$ capacitors, each having a maximum voltage capability of 50 V . (a) What combination of these capacitors has the proper electrical characteristics? Will the technician use all the capacitors in the box? Explain your answers. (b) In the combination of capacitors obtained in part (a), what will be the maximum voltage across each of the capacitors used?

Challenge Problems

72. The inner conductor of a coaxial cable has a radius of 0.800 mm , and the outer conductor's inside radius is 3.00 mm . The space between the conductors is filled with polyethylene, which has a dielectric constant of 2.30 and a dielectric strength of $18.0 \times 10^6\text{ V/m}$. What is the maximum potential difference this cable can withstand?

73. Some physical systems possessing capacitance continuously distributed over space can be modeled as an infinite array of discrete circuit elements. Examples are a microwave waveguide and the axon of a nerve cell. To practice analysis of an infinite array, determine the equivalent capacitance C between terminals X and Y of the infinite set of capacitors represented in Figure P26.73. Each capacitor has capacitance C_0 . *Suggestion:* Imagine that the ladder is cut at the line AB and note that the equivalent capacitance of the infinite section to the right of AB is also C .

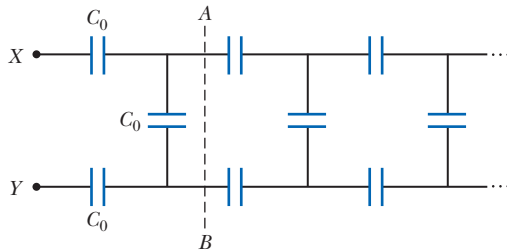

Figure P26.73

74. Consider two long, parallel, and oppositely charged wires of radius r with their centers separated by a distance D that is much larger than r . Assuming the charge is distributed uniformly on the surface of each wire, show that the capacitance per unit length of this pair of wires is

$$\frac{C}{\ell} = \frac{\pi\epsilon_0}{\ln(D/r)}$$

75. Determine the equivalent capacitance of the combination shown in Figure P26.75. *Suggestion:* Consider the symmetry involved.

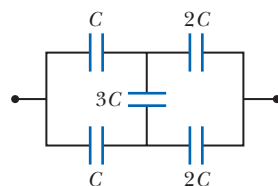

Figure P26.75

76. A parallel-plate capacitor with plates of area LW and plate separation t has the region between its plates filled with wedges of two dielectric materials as shown in Figure P26.76. Assume t is much less than both L and W . (a) Determine its capacitance. (b) Should the capacitance be the same if the labels κ_1 and κ_2 are interchanged? Demonstrate that your expression does or does not have this property. (c) Show that if κ_1 and κ_2 approach equality to a common value κ , your result becomes the same as the capacitance of a capacitor containing a single dielectric: $C = \kappa\epsilon_0 LW/t$.

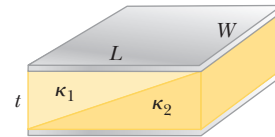

Figure P26.76

77. Calculate the equivalent capacitance between points a and b in Figure P26.77. Notice that this system is not a simple series or parallel combination. *Suggestion:* Assume a potential difference ΔV between points a and b . Write expressions for ΔV_{ab} in terms of the charges and capacitances for the various possible pathways from a to b and require conservation of charge for those capacitor plates that are connected to each other.

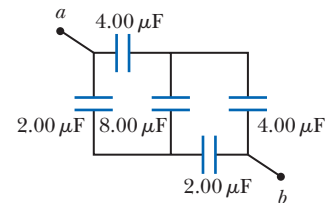

Figure P26.77

78. A capacitor is constructed from two square, metallic plates of sides ℓ and separation d . Charges $+Q$ and $-Q$ are placed on the plates, and the power supply is then removed. A material of dielectric constant κ is inserted a distance x into the capacitor as shown in Figure P26.78. Assume d is much smaller than x . (a) Find the equivalent capacitance of the device. (b) Calculate the energy stored in the capacitor. (c) Find the direction and magnitude of the force exerted by the plates on the dielectric. (d) Obtain a numerical value for the force when $x = \ell/2$, assuming $\ell = 5.00\text{ cm}$, $d = 2.00\text{ mm}$, the dielectric is glass ($\kappa = 4.50$), and the capacitor was charged to $2.00 \times 10^3\text{ V}$ before the dielectric was inserted. *Suggestion:* The system can be considered as two capacitors connected in parallel.

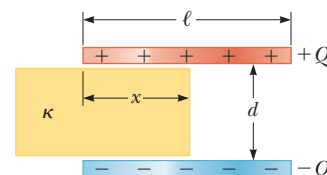

Figure P26.78

Current and Resistance

- 27.1 Electric Current
- 27.2 Resistance
- 27.3 A Model for Electrical Conduction
- 27.4 Resistance and Temperature
- 27.5 Superconductors
- 27.6 Electrical Power



These two lightbulbs provide similar power output by visible light (electromagnetic radiation). The compact fluorescent bulb on the left, however, produces this light output with far less input by electrical transmission than the incandescent bulb on the right. The fluorescent bulb, therefore, is less costly to operate and saves valuable resources needed to generate electricity. (Christina Richards/Shutterstock.com)

We now consider situations involving electric charges that are in motion through some region of space. We use the term *electric current*, or simply *current*, to describe the rate of flow of charge. Most practical applications of electricity deal with electric currents, including a variety of home appliances. For example, the voltage from a wall plug produces a current in the coils of a toaster when it is turned on. In these common situations, current exists in a conductor such as a copper wire. Currents can also exist outside a conductor. For instance, a beam of electrons in a particle accelerator constitutes a current.

This chapter begins with the definition of current. A microscopic description of current is given, and some factors that contribute to the opposition to the flow of charge in conductors are discussed. A classical model is used to describe electrical conduction in metals, and some limitations of this model are cited. We also define electrical resistance and introduce a new circuit element, the resistor. We conclude by discussing the rate at which energy is transferred to a device in an electric circuit. The energy transfer mechanism in Equation 8.2 that corresponds to this process is electrical transmission T_{ET} .

27.1 Electric Current

In this section, we study the flow of electric charges through a piece of material. The amount of flow depends on both the material through which the charges are

passing and the potential difference across the material. Whenever there is a net flow of charge through some region, an electric *current* is said to exist.

It is instructive to draw an analogy between water flow and current. The flow of water in a plumbing pipe can be quantified by specifying the amount of water that emerges from a faucet during a given time interval, often measured in liters per minute. A river current can be characterized by describing the rate at which the water flows past a particular location. For example, the flow over the brink at Niagara Falls is maintained at rates between 1 400 m³/s and 2 800 m³/s.

There is also an analogy between thermal conduction and current. In Section 20.7, we discussed the flow of energy by heat through a sample of material. The rate of energy flow is determined by the material as well as the temperature difference across the material as described by Equation 20.15.

To define current quantitatively, suppose charges are moving perpendicular to a surface of area A as shown in Figure 27.1. (This area could be the cross-sectional area of a wire, for example.) The **current** is defined as the rate at which charge flows through this surface. If ΔQ is the amount of charge that passes through this surface in a time interval Δt , the **average current** I_{avg} is equal to the charge that passes through A per unit time:

$$I_{\text{avg}} = \frac{\Delta Q}{\Delta t} \quad (27.1)$$

If the rate at which charge flows varies in time, the current varies in time; we define the **instantaneous current** I as the limit of the average current as $\Delta t \rightarrow 0$:

$$I \equiv \frac{dQ}{dt} \quad (27.2)$$

The SI unit of current is the **ampere** (A):

$$1 \text{ A} = 1 \text{ C/s} \quad (27.3)$$

That is, 1 A of current is equivalent to 1 C of charge passing through a surface in 1 s.

The charged particles passing through the surface in Figure 27.1 can be positive, negative, or both. It is conventional to assign to the current the same direction as the flow of positive charge. In electrical conductors such as copper or aluminum, the current results from the motion of negatively charged electrons. Therefore, in an ordinary conductor, the direction of the current is opposite the direction of flow of electrons. For a beam of positively charged protons in an accelerator, however, the current is in the direction of motion of the protons. In some cases—such as those involving gases and electrolytes, for instance—the current is the result of the flow of both positive and negative charges. It is common to refer to a moving charge (positive or negative) as a mobile **charge carrier**.

If the ends of a conducting wire are connected to form a loop, all points on the loop are at the same electric potential; hence, the electric field is zero within and at the surface of the conductor. Because the electric field is zero, there is no net transport of charge through the wire; therefore, there is no current. If the ends of the conducting wire are connected to a battery, however, all points on the loop are not at the same potential. The battery sets up a potential difference between the ends of the loop, creating an electric field within the wire. The electric field exerts forces on the electrons in the wire, causing them to move in the wire and therefore creating a current.

Microscopic Model of Current

We can relate current to the motion of the charge carriers by describing a microscopic model of conduction in a metal. Consider the current in a cylindrical

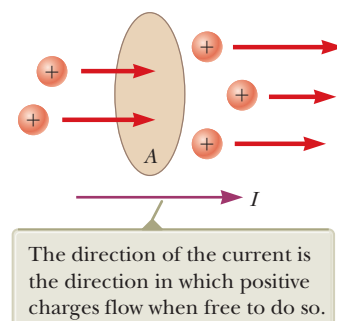

Figure 27.1 Charges in motion through an area A . The time rate at which charge flows through the area is defined as the current I .

◀ Electric current

Pitfall Prevention 27.1

"Current Flow" Is Redundant

The phrase *current flow* is commonly used, although it is technically incorrect because current is a flow (of charge). This wording is similar to the phrase *heat transfer*, which is also redundant because heat is a transfer (of energy). We will avoid this phrase and speak of *flow of charge* or *charge flow*.

Pitfall Prevention 27.2

Batteries Do Not Supply Electrons

A battery does not supply electrons to the circuit. It establishes the electric field that exerts a force on electrons already in the wires and elements of the circuit.

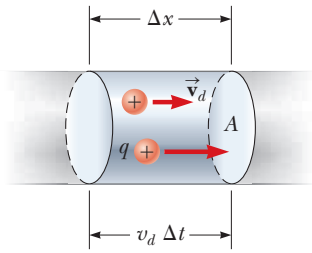
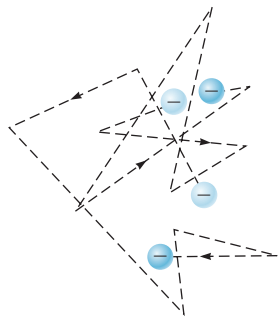

Figure 27.2 A segment of a uniform conductor of cross-sectional area A .



The random motion of the charge carriers is modified by the field, and they have a drift velocity opposite the direction of the electric field.

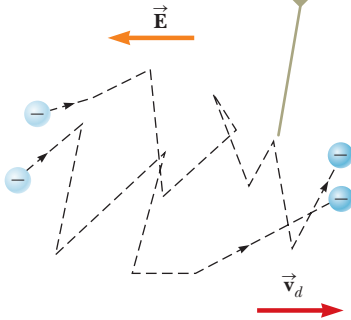

Figure 27.3 (a) A schematic diagram of the random motion of two charge carriers in a conductor in the absence of an electric field. The drift velocity is zero. (b) The motion of the charge carriers in a conductor in the presence of an electric field. Because of the acceleration of the charge carriers due to the electric force, the paths are actually parabolic. The drift speed, however, is much smaller than the average speed, so the parabolic shape is not visible on this scale.

conductor of cross-sectional area A (Fig. 27.2). The volume of a segment of the conductor of length Δx (between the two circular cross sections shown in Fig. 27.2) is $A \Delta x$. If n represents the number of mobile charge carriers per unit volume (in other words, the charge carrier density), the number of carriers in the segment is $nA \Delta x$. Therefore, the total charge ΔQ in this segment is

$$\Delta Q = (nA \Delta x)q$$

where q is the charge on each carrier. If the carriers move with a velocity \vec{v}_d parallel to the axis of the cylinder, the magnitude of the displacement they experience in the x direction in a time interval Δt is $\Delta x = v_d \Delta t$. Let Δt be the time interval required for the charge carriers in the segment to move through a displacement whose magnitude is equal to the length of the segment. This time interval is also the same as that required for all the charge carriers in the segment to pass through the circular area at one end. With this choice, we can write ΔQ as

$$\Delta Q = (nAv_d \Delta t)q$$

Dividing both sides of this equation by Δt , we find that the average current in the conductor is

$$I_{\text{avg}} = \frac{\Delta Q}{\Delta t} = nqv_d A \quad (27.4)$$

In reality, the speed of the charge carriers v_d is an average speed called the **drift speed**. To understand the meaning of drift speed, consider a conductor in which the charge carriers are free electrons. If the conductor is isolated—that is, the potential difference across it is zero—these electrons undergo random motion that is analogous to the motion of gas molecules. The electrons collide repeatedly with the metal atoms, and their resultant motion is complicated and zigzagged as in Figure 27.3a. As discussed earlier, when a potential difference is applied across the conductor (for example, by means of a battery), an electric field is set up in the conductor; this field exerts an electric force on the electrons, producing a current. In addition to the zigzag motion due to the collisions with the metal atoms, the electrons move slowly along the conductor (in a direction opposite that of \vec{E}) at the **drift velocity** \vec{v}_d as shown in Figure 27.3b.

You can think of the atom–electron collisions in a conductor as an effective internal friction (or drag force) similar to that experienced by a liquid’s molecules flowing through a pipe stuffed with steel wool. The energy transferred from the electrons to the metal atoms during collisions causes an increase in the atom’s vibrational energy and a corresponding increase in the conductor’s temperature.

Quick Quiz 27.1 Consider positive and negative charges moving horizontally through the four regions shown in Figure 27.4. Rank the current in these four regions from highest to lowest.

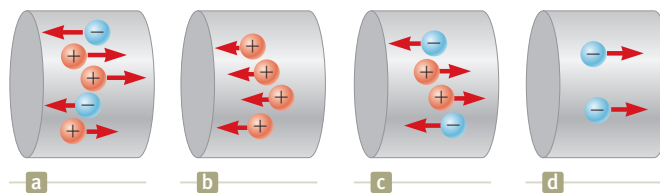

Figure 27.4 (Quick Quiz 27.1) Charges move through four regions.

Example 27.1 Drift Speed in a Copper Wire

The 12-gauge copper wire in a typical residential building has a cross-sectional area of $3.31 \times 10^{-6} \text{ m}^2$. It carries a constant current of 10.0 A. What is the drift speed of the electrons in the wire? Assume each copper atom contributes one free electron to the current. The density of copper is 8.92 g/cm^3 .

SOLUTION

Conceptualize Imagine electrons following a zigzag motion such as that in Figure 27.3a, with a drift velocity parallel to the wire superimposed on the motion as in Figure 27.3b. As mentioned earlier, the drift speed is small, and this example helps us quantify the speed.

Categorize We evaluate the drift speed using Equation 27.4. Because the current is constant, the average current during any time interval is the same as the constant current: $I_{\text{avg}} = I$.

Analyze The periodic table of the elements in Appendix C shows that the molar mass of copper is $M = 63.5 \text{ g/mol}$. Recall that 1 mol of any substance contains Avogadro's number of atoms ($N_A = 6.02 \times 10^{23} \text{ mol}^{-1}$).

Use the molar mass and the density of copper to find the volume of 1 mole of copper:

$$V = \frac{M}{\rho}$$

From the assumption that each copper atom contributes one free electron to the current, find the electron density in copper:

$$n = \frac{N_A}{V} = \frac{N_A \rho}{M}$$

Solve Equation 27.4 for the drift speed and substitute for the electron density:

$$v_d = \frac{I_{\text{avg}}}{nqA} = \frac{I}{nqA} = \frac{IM}{qAN_A\rho}$$

Substitute numerical values:

$$\begin{aligned} v_d &= \frac{(10.0 \text{ A})(0.0635 \text{ kg/mol})}{(1.60 \times 10^{-19} \text{ C})(3.31 \times 10^{-6} \text{ m}^2)(6.02 \times 10^{23} \text{ mol}^{-1})(8920 \text{ kg/m}^3)} \\ &= 2.23 \times 10^{-4} \text{ m/s} \end{aligned}$$

Finalize This result shows that typical drift speeds are very small. For instance, electrons traveling with a speed of $2.23 \times 10^{-4} \text{ m/s}$ would take about 75 min to travel 1 m! You might therefore wonder why a light turns on almost instantaneously when its switch is thrown. In a conductor, changes in the electric field that drives the free electrons according to the particle in a field model travel through the conductor with a speed close to that of light. So, when you flip on a light switch, electrons already in the filament of the lightbulb experience electric forces and begin moving after a time interval on the order of nanoseconds.

27.2 Resistance

In Section 24.4, we argued that the electric field inside a conductor is zero. This statement is true, however, *only* if the conductor is in static equilibrium as stated in that discussion. The purpose of this section is to describe what happens when there is a nonzero electric field in the conductor. As we saw in Section 27.1, a current exists in the wire in this case.

Consider a conductor of cross-sectional area A carrying a current I . The **current density** J in the conductor is defined as the current per unit area. Because the current $I = nqv_d A$, the current density is

$$J \equiv \frac{I}{A} = nqv_d \quad (27.5) \quad \leftarrow \text{Current density}$$



© Bettmann/Corbis

Georg Simon Ohm

German physicist (1789–1854)

Ohm, a high school teacher and later a professor at the University of Munich, formulated the concept of resistance and discovered the proportionalities expressed in Equations 27.6 and 27.7.

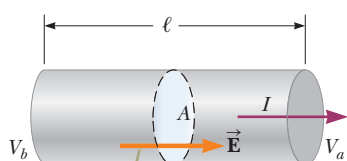

A potential difference $\Delta V = V_b - V_a$ maintained across the conductor sets up an electric field \vec{E} , and this field produces a current I that is proportional to the potential difference.

Figure 27.5 A uniform conductor of length ℓ and cross-sectional area A .

Pitfall Prevention 27.3

Equation 27.7 Is Not Ohm's Law

Many individuals call Equation 27.7 Ohm's law, but that is incorrect. This equation is simply the definition of resistance, and it provides an important relationship between voltage, current, and resistance. Ohm's law is related to a proportionality of J to E (Eq. 27.6) or, equivalently, of I to ΔV , which, from Equation 27.7, indicates that the resistance is constant, independent of the applied voltage. We will see some devices for which Equation 27.7 correctly describes their resistance, but that do *not* obey Ohm's law.

where J has SI units of amperes per meter squared. This expression is valid only if the current density is uniform and only if the surface of cross-sectional area A is perpendicular to the direction of the current.

A current density and an electric field are established in a conductor whenever a potential difference is maintained across the conductor. In some materials, the current density is proportional to the electric field:

$$J = \sigma E \quad (27.6)$$

where the constant of proportionality σ is called the **conductivity** of the conductor.¹ Materials that obey Equation 27.6 are said to follow **Ohm's law**, named after Georg Simon Ohm. More specifically, Ohm's law states the following:

For many materials (including most metals), the ratio of the current density to the electric field is a constant σ that is independent of the electric field producing the current.

Materials and devices that obey Ohm's law and hence demonstrate this simple relationship between E and J are said to be *ohmic*. Experimentally, however, it is found that not all materials and devices have this property. Those that do not obey Ohm's law are said to be *nonohmic*. Ohm's law is not a fundamental law of nature; rather, it is an empirical relationship valid only for certain situations.

We can obtain an equation useful in practical applications by considering a segment of straight wire of uniform cross-sectional area A and length ℓ as shown in Figure 27.5. A potential difference $\Delta V = V_b - V_a$ is maintained across the wire, creating in the wire an electric field and a current. If the field is assumed to be uniform, the magnitude of the potential difference across the wire is related to the field within the wire through Equation 25.6,

$$\Delta V = E\ell$$

Therefore, we can express the current density (Eq. 27.6) in the wire as

$$J = \sigma \frac{\Delta V}{\ell}$$

Because $J = I/A$, the potential difference across the wire is

$$\Delta V = \frac{\ell}{\sigma} J = \left(\frac{\ell}{\sigma A} \right) I = R I$$

The quantity $R = \ell/\sigma A$ is called the **resistance** of the conductor. We define the resistance as the ratio of the potential difference across a conductor to the current in the conductor:

$$R \equiv \frac{\Delta V}{I} \quad (27.7)$$

We will use this equation again and again when studying electric circuits. This result shows that resistance has SI units of volts per ampere. One volt per ampere is defined to be one **ohm** (Ω):

$$1 \Omega \equiv 1 \text{ V/A} \quad (27.8)$$

Equation 27.7 shows that if a potential difference of 1 V across a conductor causes a current of 1 A, the resistance of the conductor is 1 Ω . For example, if an electrical appliance connected to a 120-V source of potential difference carries a current of 6 A, its resistance is 20 Ω .

Most electric circuits use circuit elements called **resistors** to control the current in the various parts of the circuit. As with capacitors in Chapter 26, many resistors are built into integrated circuit chips, but stand-alone resistors are still available and

¹Do not confuse conductivity σ with surface charge density, for which the same symbol is used.

Table 27.1 Color Coding for Resistors

Color	Number	Multiplier	Tolerance
Black	0	1	
Brown	1	10^1	
Red	2	10^2	
Orange	3	10^3	
Yellow	4	10^4	
Green	5	10^5	
Blue	6	10^6	
Violet	7	10^7	
Gray	8	10^8	
White	9	10^9	
Gold		10^{-1}	5%
Silver		10^{-2}	10%
Colorless			20%

widely used. Two common types are the *composition resistor*, which contains carbon, and the *wire-wound resistor*, which consists of a coil of wire. Values of resistors in ohms are normally indicated by color coding as shown in Figure 27.6 and Table 27.1. The first two colors on a resistor give the first two digits in the resistance value, with the decimal place to the right of the second digit. The third color represents the power of 10 for the multiplier of the resistance value. The last color is the tolerance of the resistance value. As an example, the four colors on the resistor at the bottom of Figure 27.6 are yellow (= 4), violet (= 7), black (= 10^0), and gold (= 5%), and so the resistance value is $47 \times 10^0 = 47 \Omega$ with a tolerance value of $5\% = 2 \Omega$.

The inverse of conductivity is **resistivity**² ρ :

$$\rho = \frac{1}{\sigma} \quad (27.9)$$

where ρ has the units ohm \cdot meters ($\Omega \cdot \text{m}$). Because $R = \ell/\sigma A$, we can express the resistance of a uniform block of material along the length ℓ as

$$R = \rho \frac{\ell}{A} \quad (27.10)$$

Every ohmic material has a characteristic resistivity that depends on the properties of the material and on temperature. In addition, as you can see from Equation 27.10, the resistance of a sample of the material depends on the geometry of the sample as well as on the resistivity of the material. Table 27.2 (page 814) gives the resistivities of a variety of materials at 20°C . Notice the enormous range, from very low values for good conductors such as copper and silver to very high values for good insulators such as glass and rubber. An ideal conductor would have zero resistivity, and an ideal insulator would have infinite resistivity.

Equation 27.10 shows that the resistance of a given cylindrical conductor such as a wire is proportional to its length and inversely proportional to its cross-sectional area. If the length of a wire is doubled, its resistance doubles. If its cross-sectional area is doubled, its resistance decreases by one half. The situation is analogous to the flow of a liquid through a pipe. As the pipe's length is increased, the resistance to flow increases. As the pipe's cross-sectional area is increased, more liquid crosses a given cross section of the pipe per unit time interval. Therefore, more liquid flows for the same pressure differential applied to the pipe, and the resistance to flow decreases.

Ohmic materials and devices have a linear current–potential difference relationship over a broad range of applied potential differences (Fig. 27.7a, page 814). The slope of the I -versus- ΔV curve in the linear region yields a value for $1/R$. Nonohmic

The colored bands on this resistor are yellow, violet, black, and gold.

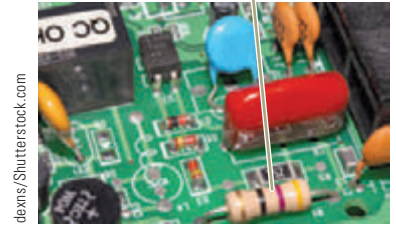

Figure 27.6 A close-up view of a circuit board shows the color coding on a resistor. The gold band on the left tells us that the resistor is oriented “backward” in this view and we need to read the colors from right to left.

◀ Resistivity is the inverse of conductivity

◀ Resistance of a uniform material along the length ℓ

Pitfall Prevention 27.4

Resistance and Resistivity Resistivity is a property of a *substance*, whereas resistance is a property of an *object*. We have seen similar pairs of variables before. For example, density is a property of a substance, whereas mass is a property of an object. Equation 27.10 relates resistance to resistivity, and Equation 1.1 relates mass to density.

²Do not confuse resistivity ρ with mass density or charge density, for which the same symbol is used.

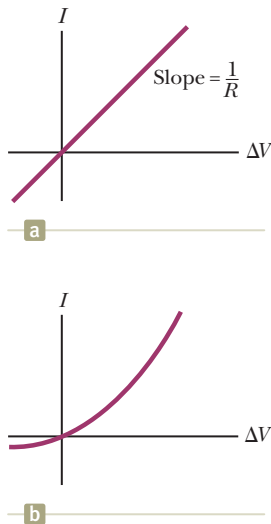

Figure 27.7 (a) The current–potential difference curve for an ohmic material. The curve is linear, and the slope is equal to the inverse of the resistance of the conductor. (b) A nonlinear current–potential difference curve for a junction diode. This device does not obey Ohm’s law.

Table 27.2 Resistivities and Temperature Coefficients of Resistivity for Various Materials

Material	Resistivity ^a ($\Omega \cdot \text{m}$)	Temperature Coefficient ^b α [$(^\circ\text{C})^{-1}$]
Silver	1.59×10^{-8}	3.8×10^{-3}
Copper	1.7×10^{-8}	3.9×10^{-3}
Gold	2.44×10^{-8}	3.4×10^{-3}
Aluminum	2.82×10^{-8}	3.9×10^{-3}
Tungsten	5.6×10^{-8}	4.5×10^{-3}
Iron	10×10^{-8}	5.0×10^{-3}
Platinum	11×10^{-8}	3.92×10^{-3}
Lead	22×10^{-8}	3.9×10^{-3}
Nichrome ^c	1.00×10^{-6}	0.4×10^{-3}
Carbon	3.5×10^{-5}	-0.5×10^{-3}
Germanium	0.46	-48×10^{-3}
Silicon ^d	2.3×10^3	-75×10^{-3}
Glass	10^{10} to 10^{14}	
Hard rubber	$\sim 10^{13}$	
Sulfur	10^{15}	
Quartz (fused)	75×10^{16}	

^a All values at 20°C . All elements in this table are assumed to be free of impurities.

^b See Section 27.4.

^c A nickel–chromium alloy commonly used in heating elements. The resistivity of Nichrome varies with composition and ranges between 1.00×10^{-6} and $1.50 \times 10^{-6} \Omega \cdot \text{m}$.

^d The resistivity of silicon is very sensitive to purity. The value can be changed by several orders of magnitude when it is doped with other atoms.

materials have a nonlinear current–potential difference relationship. One common semiconducting device with nonlinear I -versus- ΔV characteristics is the *junction diode* (Fig. 27.7b). The resistance of this device is low for currents in one direction (positive ΔV) and high for currents in the reverse direction (negative ΔV). In fact, most modern electronic devices, such as transistors, have nonlinear current–potential difference relationships; their proper operation depends on the particular way they violate Ohm’s law.

Quick Quiz 27.2 A cylindrical wire has a radius r and length ℓ . If both r and ℓ are doubled, does the resistance of the wire (a) increase, (b) decrease, or (c) remain the same?

Quick Quiz 27.3 In Figure 27.7b, as the applied voltage increases, does the resistance of the diode (a) increase, (b) decrease, or (c) remain the same?

Example 27.2 The Resistance of Nichrome Wire

The radius of 22-gauge Nichrome wire is 0.32 mm.

(A) Calculate the resistance per unit length of this wire.

SOLUTION

Conceptualize Table 27.2 shows that Nichrome has a resistivity two orders of magnitude larger than the best conductors in the table. Therefore, we expect it to have some special practical applications that the best conductors may not have.

Categorize We model the wire as a cylinder so that a simple geometric analysis can be applied to find the resistance.

Analyze Use Equation 27.10 and the resistivity of Nichrome from Table 27.2 to find the resistance per unit length:

$$\frac{R}{\ell} = \frac{\rho}{A} = \frac{\rho}{\pi r^2} = \frac{1.0 \times 10^{-6} \Omega \cdot \text{m}}{\pi(0.32 \times 10^{-3} \text{ m})^2} = 3.1 \Omega/\text{m}$$

27.2 continued

(B) If a potential difference of 10 V is maintained across a 1.0-m length of the Nichrome wire, what is the current in the wire?

SOLUTION

Analyze Use Equation 27.7 to find the current:

$$I = \frac{\Delta V}{R} = \frac{\Delta V}{(R/\ell)\ell} = \frac{10 \text{ V}}{(3.1 \text{ } \Omega/\text{m})(1.0 \text{ m})} = 3.2 \text{ A}$$

Finalize Because of its high resistivity and resistance to oxidation, Nichrome is often used for heating elements in toasters, irons, and electric heaters.

WHAT IF? What if the wire were composed of copper instead of Nichrome? How would the values of the resistance per unit length and the current change?

Answer Table 27.2 shows us that copper has a resistivity two orders of magnitude smaller than that for Nichrome. Therefore, we expect the answer to part (A) to be smaller and the answer to part (B) to be larger. Calculations show that a copper wire of the same radius would have a resistance per unit length of only $0.053 \text{ } \Omega/\text{m}$. A 1.0-m length of copper wire of the same radius would carry a current of 190 A with an applied potential difference of 10 V.

Example 27.3 The Radial Resistance of a Coaxial Cable

Coaxial cables are used extensively for cable television and other electronic applications. A coaxial cable consists of two concentric cylindrical conductors. The region between the conductors is completely filled with polyethylene plastic as shown in Figure 27.8a. Current leakage through the plastic, in the *radial* direction, is unwanted. (The cable is designed to conduct current along its length, but that is *not* the current being considered here.) The radius of the inner conductor is $a = 0.500 \text{ cm}$, the radius of the outer conductor is $b = 1.75 \text{ cm}$, and the length is $L = 15.0 \text{ cm}$. The resistivity of the plastic is $1.0 \times 10^{13} \text{ } \Omega \cdot \text{m}$. Calculate the resistance of the plastic between the two conductors.

SOLUTION

Conceptualize Imagine two currents as suggested in the text of the problem. The desired current is along the cable, carried within the conductors. The undesired current corresponds to leakage through the plastic, and its direction is radial.

Categorize Because the resistivity and the geometry of the plastic are known, we categorize this problem as one in which we find the resistance of the plastic from these parameters. Equation 27.10, however, represents the resistance of a block of material. We have a more complicated geometry in this situation. Because the area through which the charges pass depends on the radial position, we must use integral calculus to determine the answer.

Analyze We divide the plastic into concentric cylindrical shells of infinitesimal thickness dr (Fig. 27.8b). Any charge passing from the inner to the outer conductor must move radially through this shell. Use a differential form of Equation 27.10, replacing ℓ with dr for the length variable: $dR = \rho \, dr/A$, where dR is the resistance of a shell of plastic of thickness dr and surface area A .

Write an expression for the resistance of our hollow cylindrical shell of plastic representing the area as the surface area of the shell:

$$dR = \frac{\rho \, dr}{A} = \frac{\rho}{2\pi r L} \, dr$$

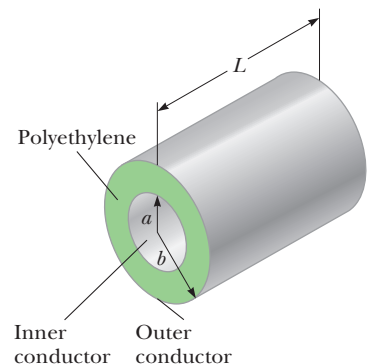

a

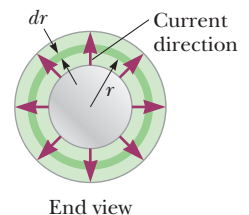

End view

b

Figure 27.8 (Example 27.3) A coaxial cable. (a) Polyethylene plastic fills the gap between the two conductors. (b) End view, showing current leakage.

continued

▶ 27.3 continued

Integrate this expression from $r = a$ to $r = b$:

$$(1) \quad R = \int dR = \frac{\rho}{2\pi L} \int_a^b \frac{dr}{r} = \frac{\rho}{2\pi L} \ln\left(\frac{b}{a}\right)$$

Substitute the values given:

$$R = \frac{1.0 \times 10^{13} \Omega \cdot \text{m}}{2\pi(0.150 \text{ m})} \ln\left(\frac{1.75 \text{ cm}}{0.500 \text{ cm}}\right) = 1.33 \times 10^{13} \Omega$$

Finalize Let's compare this resistance to that of the inner copper conductor of the cable along the 15.0-cm length.

Use Equation 27.10 to find the resistance of the copper cylinder:

$$\begin{aligned} R_{\text{Cu}} &= \rho \frac{\ell}{A} = (1.7 \times 10^{-8} \Omega \cdot \text{m}) \left[\frac{0.150 \text{ m}}{\pi(5.00 \times 10^{-3} \text{ m})^2} \right] \\ &= 3.2 \times 10^{-5} \Omega \end{aligned}$$

This resistance is 18 orders of magnitude smaller than the radial resistance. Therefore, almost all the current corresponds to charge moving along the length of the cable, with a very small fraction leaking in the radial direction.

WHAT IF? Suppose the coaxial cable is enlarged to twice the overall diameter with two possible choices: (1) the ratio b/a is held fixed, or (2) the difference $b - a$ is held fixed. For which choice does the leakage current between the inner and outer conductors increase when the voltage is applied between them?

Answer For the current to increase, the resistance must decrease. For choice (1), in which b/a is held fixed, Equa-

tion (1) shows that the resistance is unaffected. For choice (2), we do not have an equation involving the difference $b - a$ to inspect. Looking at Figure 27.8b, however, we see that increasing b and a while holding the difference constant results in charge flowing through the same thickness of plastic but through a larger area perpendicular to the flow. This larger area results in lower resistance and a higher current.

27.3 A Model for Electrical Conduction

In this section, we describe a structural model of electrical conduction in metals that was first proposed by Paul Drude (1863–1906) in 1900. (See Section 21.1 for a review of structural models.) This model leads to Ohm's law and shows that resistivity can be related to the motion of electrons in metals. Although the Drude model described here has limitations, it introduces concepts that are applied in more elaborate treatments.

Following the outline of structural models from Section 21.1, the Drude model for electrical conduction has the following properties:

1. *Physical components:*

Consider a conductor as a regular array of atoms plus a collection of free electrons, which are sometimes called *conduction* electrons. We identify the system as the combination of the atoms and the conduction electrons. The conduction electrons, although bound to their respective atoms when the atoms are not part of a solid, become free when the atoms condense into a solid.

2. *Behavior of the components:*

- In the absence of an electric field, the conduction electrons move in random directions through the conductor (Fig. 27.3a). The situation is similar to the motion of gas molecules confined in a vessel. In fact, some scientists refer to conduction electrons in a metal as an *electron gas*.
- When an electric field is applied to the system, the free electrons drift slowly in a direction opposite that of the electric field (Fig. 27.3b), with an average drift speed v_d that is much smaller (typically 10^{-4} m/s) than their average speed v_{avg} between collisions (typically 10^6 m/s).
- The electron's motion after a collision is independent of its motion before the collision. The excess energy acquired by the electrons due to

the work done on them by the electric field is transferred to the atoms of the conductor when the electrons and atoms collide.

With regard to property 2(c) above, the energy transferred to the atoms causes the internal energy of the system and, therefore, the temperature of the conductor to increase.

We are now in a position to derive an expression for the drift velocity, using several of our analysis models. When a free electron of mass m_e and charge $q (= -e)$ is subjected to an electric field $\vec{\mathbf{E}}$, it is described by the particle in a field model and experiences a force $\vec{\mathbf{F}} = q\vec{\mathbf{E}}$. The electron is a particle under a net force, and its acceleration can be found from Newton's second law, $\sum \vec{\mathbf{F}} = m\vec{\mathbf{a}}$:

$$\vec{\mathbf{a}} = \frac{\sum \vec{\mathbf{F}}}{m} = \frac{q\vec{\mathbf{E}}}{m_e} \quad (27.11)$$

Because the electric field is uniform, the electron's acceleration is constant, so the electron can be modeled as a particle under constant acceleration. If $\vec{\mathbf{v}}_i$ is the electron's initial velocity the instant after a collision (which occurs at a time defined as $t = 0$), the velocity of the electron at a very short time t later (immediately before the next collision occurs) is, from Equation 4.8,

$$\vec{\mathbf{v}}_f = \vec{\mathbf{v}}_i + \vec{\mathbf{a}}t = \vec{\mathbf{v}}_i + \frac{q\vec{\mathbf{E}}}{m_e} t \quad (27.12)$$

Let's now take the average value of $\vec{\mathbf{v}}_f$ for all the electrons in the wire over all possible collision times t and all possible values of $\vec{\mathbf{v}}_i$. Assuming the initial velocities are randomly distributed over all possible directions (property 2(a) above), the average value of $\vec{\mathbf{v}}_i$ is zero. The average value of the second term of Equation 27.12 is $(q\vec{\mathbf{E}}/m_e)\tau$, where τ is the *average time interval between successive collisions*. Because the average value of $\vec{\mathbf{v}}_f$ is equal to the drift velocity,

$$\vec{\mathbf{v}}_{f,\text{avg}} = \vec{\mathbf{v}}_d = \frac{q\vec{\mathbf{E}}}{m_e} \tau \quad (27.13)$$

◀ Drift velocity in terms of microscopic quantities

The value of τ depends on the size of the metal atoms and the number of electrons per unit volume. We can relate this expression for drift velocity in Equation 27.13 to the current in the conductor. Substituting the magnitude of the velocity from Equation 27.13 into Equation 27.4, the average current in the conductor is given by

$$I_{\text{avg}} = nq \left(\frac{qE}{m_e} \tau \right) A = \frac{nq^2 E}{m_e} \tau A \quad (27.14)$$

Because the current density J is the current divided by the area A ,

$$J = \frac{nq^2 E}{m_e} \tau$$

◀ Current density in terms of microscopic quantities

where n is the number of electrons per unit volume. Comparing this expression with Ohm's law, $J = \sigma E$, we obtain the following relationships for conductivity and resistivity of a conductor:

$$\sigma = \frac{nq^2 \tau}{m_e} \quad (27.15)$$

◀ Conductivity in terms of microscopic quantities

$$\rho = \frac{1}{\sigma} = \frac{m_e}{nq^2 \tau} \quad (27.16)$$

◀ Resistivity in terms of microscopic quantities

According to this classical model, conductivity and resistivity do not depend on the strength of the electric field. This feature is characteristic of a conductor obeying Ohm's law.

The model shows that the resistivity can be calculated from a knowledge of the density of the electrons, their charge and mass, and the average time interval τ between collisions. This time interval is related to the average distance between collisions ℓ_{avg} (the *mean free path*) and the average speed v_{avg} through the expression³

$$\tau = \frac{\ell_{\text{avg}}}{v_{\text{avg}}} \quad (27.17)$$

Although this structural model of conduction is consistent with Ohm's law, it does not correctly predict the values of resistivity or the behavior of the resistivity with temperature. For example, the results of classical calculations for v_{avg} using the ideal gas model for the electrons are about a factor of ten smaller than the actual values, which results in incorrect predictions of values of resistivity from Equation 27.16. Furthermore, according to Equations 27.16 and 27.17, the resistivity is predicted to vary with temperature as does v_{avg} , which, according to an ideal-gas model (Chapter 21, Eq. 21.43), is proportional to \sqrt{T} . This behavior is in disagreement with the experimentally observed linear dependence of resistivity with temperature for pure metals. (See Section 27.4.) Because of these incorrect predictions, we must modify our structural model. We shall call the model that we have developed so far the *classical* model for electrical conduction. To account for the incorrect predictions of the classical model, we develop it further into a *quantum mechanical* model, which we shall describe briefly.

We discussed two important simplification models in earlier chapters, the particle model and the wave model. Although we discussed these two simplification models separately, quantum physics tells us that this separation is not so clear-cut. As we shall discuss in detail in Chapter 40, particles have wave-like properties. The predictions of some models can only be matched to experimental results if the model includes the wave-like behavior of particles. The structural model for electrical conduction in metals is one of these cases.

Let us imagine that the electrons moving through the metal have wave-like properties. If the array of atoms in a conductor is regularly spaced (that is, periodic), the wave-like character of the electrons makes it possible for them to move freely through the conductor and a collision with an atom is unlikely. For an idealized conductor, no collisions would occur, the mean free path would be infinite, and the resistivity would be zero. Electrons are scattered only if the atomic arrangement is irregular (not periodic), as a result of structural defects or impurities, for example. At low temperatures, the resistivity of metals is dominated by scattering caused by collisions between the electrons and impurities. At high temperatures, the resistivity is dominated by scattering caused by collisions between the electrons and the atoms of the conductor, which are continuously displaced as a result of thermal agitation, destroying the perfect periodicity. The thermal motion of the atoms makes the structure irregular (compared with an atomic array at rest), thereby reducing the electron's mean free path.

Although it is beyond the scope of this text to show this modification in detail, the classical model modified with the wave-like character of the electrons results in predictions of resistivity values that are in agreement with measured values and predicts a linear temperature dependence. Quantum notions had to be introduced in Chapter 21 to understand the temperature behavior of molar specific heats of gases. Here we have another case in which quantum physics is necessary for the model to agree with experiment. Although classical physics can explain a tremendous range of phenomena, we continue to see hints that quantum physics must be incorporated into our models. We shall study quantum physics in detail in Chapters 40 through 46.

³Recall that the average speed of a group of particles depends on the temperature of the group (Chapter 21) and is not the same as the drift speed v_d .

27.4 Resistance and Temperature

Over a limited temperature range, the resistivity of a conductor varies approximately linearly with temperature according to the expression

$$\rho = \rho_0[1 + \alpha(T - T_0)] \quad (27.18)$$

where ρ is the resistivity at some temperature T (in degrees Celsius), ρ_0 is the resistivity at some reference temperature T_0 (usually taken to be 20°C), and α is the **temperature coefficient of resistivity**. From Equation 27.18, the temperature coefficient of resistivity can be expressed as

$$\alpha = \frac{1}{\rho_0} \frac{\Delta\rho}{\Delta T} \quad (27.19)$$

where $\Delta\rho = \rho - \rho_0$ is the change in resistivity in the temperature interval $\Delta T = T - T_0$.

The temperature coefficients of resistivity for various materials are given in Table 27.2. Notice that the unit for α is degrees Celsius⁻¹ [$(^\circ\text{C})^{-1}$]. Because resistance is proportional to resistivity (Eq. 27.10), the variation of resistance of a sample is

$$R = R_0[1 + \alpha(T - T_0)] \quad (27.20)$$

where R_0 is the resistance at temperature T_0 . Use of this property enables precise temperature measurements through careful monitoring of the resistance of a probe made from a particular material.

For some metals such as copper, resistivity is nearly proportional to temperature as shown in Figure 27.9. A nonlinear region always exists at very low temperatures, however, and the resistivity usually reaches some finite value as the temperature approaches absolute zero. This residual resistivity near absolute zero is caused primarily by the collision of electrons with impurities and imperfections in the metal. In contrast, high-temperature resistivity (the linear region) is predominantly characterized by collisions between electrons and metal atoms.

Notice that three of the α values in Table 27.2 are negative, indicating that the resistivity of these materials decreases with increasing temperature. This behavior is indicative of a class of materials called *semiconductors*, first introduced in Section 23.2, and is due to an increase in the density of charge carriers at higher temperatures.

Because the charge carriers in a semiconductor are often associated with impurity atoms (as we discuss in more detail in Chapter 43), the resistivity of these materials is very sensitive to the type and concentration of such impurities.

Quick Quiz 27.4 When does an incandescent lightbulb carry more current, (a) immediately after it is turned on and the glow of the metal filament is increasing or (b) after it has been on for a few milliseconds and the glow is steady?

27.5 Superconductors

There is a class of metals and compounds whose resistance decreases to zero when they are below a certain temperature T_c , known as the **critical temperature**. These materials are known as **superconductors**. The resistance–temperature graph for a superconductor follows that of a normal metal at temperatures above T_c (Fig. 27.10). When the temperature is at or below T_c , the resistivity drops suddenly to zero. This phenomenon was discovered in 1911 by Dutch physicist Heike Kamerlingh-Onnes (1853–1926) as he worked with mercury, which is a superconductor below 4.2 K. Measurements have shown that the resistivities of superconductors below their T_c values are less than $4 \times 10^{-25} \Omega \cdot \text{m}$, or approximately 10^{17} times smaller than the resistivity of copper. In practice, these resistivities are considered to be zero.

◀ Variation of ρ with temperature

◀ Temperature coefficient of resistivity

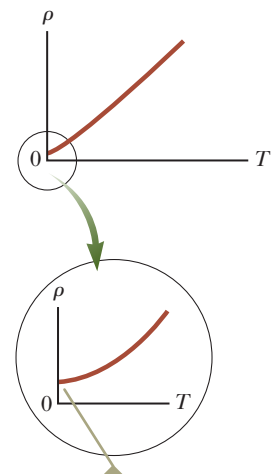

As T approaches absolute zero, the resistivity approaches a nonzero value.

Figure 27.9 Resistivity versus temperature for a metal such as copper. The curve is linear over a wide range of temperatures, and ρ increases with increasing temperature.

The resistance drops discontinuously to zero at T_c , which is 4.15 K for mercury.

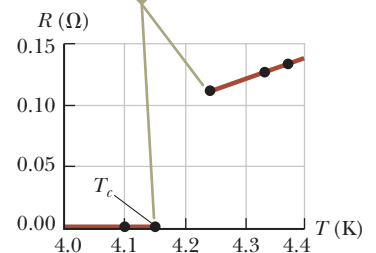

Figure 27.10 Resistance versus temperature for a sample of mercury (Hg). The graph follows that of a normal metal above the critical temperature T_c .



Courtesy of IBM Research Laboratory

A small permanent magnet levitated above a disk of the superconductor $\text{YBa}_2\text{Cu}_3\text{O}_7$, which is in liquid nitrogen at 77 K.

Table 27.3 Critical Temperatures for Various Superconductors

Material	T_c (K)
$\text{HgBa}_2\text{Ca}_2\text{Cu}_3\text{O}_8$	134
Tl—Ba—Ca—Cu—O	125
Bi—Sr—Ca—Cu—O	105
$\text{YBa}_2\text{Cu}_3\text{O}_7$	92
Nb_3Ge	23.2
Nb_3Sn	18.05
Nb	9.46
Pb	7.18
Hg	4.15
Sn	3.72
Al	1.19
Zn	0.88

Today, thousands of superconductors are known, and as Table 27.3 illustrates, the critical temperatures of recently discovered superconductors are substantially higher than initially thought possible. Two kinds of superconductors are recognized. The more recently identified ones are essentially ceramics with high critical temperatures, whereas superconducting materials such as those observed by Kamerlingh-Onnes are metals. If a room-temperature superconductor is ever identified, its effect on technology could be tremendous.

The value of T_c is sensitive to chemical composition, pressure, and molecular structure. Copper, silver, and gold, which are excellent conductors, do not exhibit superconductivity.

One truly remarkable feature of superconductors is that once a current is set up in them, it persists *without any applied potential difference* (because $R = 0$). Steady currents have been observed to persist in superconducting loops for several years with no apparent decay!

An important and useful application of superconductivity is in the development of superconducting magnets, in which the magnitudes of the magnetic field are approximately ten times greater than those produced by the best normal electromagnets. Such superconducting magnets are being considered as a means of storing energy. Superconducting magnets are currently used in medical magnetic resonance imaging, or MRI, units, which produce high-quality images of internal organs without the need for excessive exposure of patients to x-rays or other harmful radiation.

27.6 Electrical Power

In typical electric circuits, energy T_{ET} is transferred by electrical transmission from a source such as a battery to some device such as a lightbulb or a radio receiver. Let's determine an expression that will allow us to calculate the rate of this energy transfer. First, consider the simple circuit in Figure 27.11, where energy is delivered to a resistor. (Resistors are designated by the circuit symbol $\text{---}\text{---}\text{---}$.) Because the connecting wires also have resistance, some energy is delivered to the wires and some to the resistor. Unless noted otherwise, we shall assume the resistance of the wires is small compared with the resistance of the circuit element so that the energy delivered to the wires is negligible.

Imagine following a positive quantity of charge Q moving clockwise around the circuit in Figure 27.11 from point a through the battery and resistor back to point a . We identify the entire circuit as our system. As the charge moves from a to b through the battery, the electric potential energy of the system *increases* by an amount $Q\Delta V$

The direction of the effective flow of positive charge is clockwise.

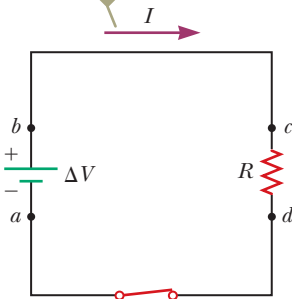

Figure 27.11 A circuit consisting of a resistor of resistance R and a battery having a potential difference ΔV across its terminals.

while the chemical potential energy in the battery *decreases* by the same amount. (Recall from Eq. 25.3 that $\Delta U = q\Delta V$.) As the charge moves from *c* to *d* through the resistor, however, the electric potential energy of the system decreases due to collisions of electrons with atoms in the resistor. In this process, the electric potential energy is transformed to internal energy corresponding to increased vibrational motion of the atoms in the resistor. Because the resistance of the interconnecting wires is neglected, no energy transformation occurs for paths *bc* and *da*. When the charge returns to point *a*, the net result is that some of the chemical potential energy in the battery has been delivered to the resistor and resides in the resistor as internal energy E_{int} associated with molecular vibration.

The resistor is normally in contact with air, so its increased temperature results in a transfer of energy by heat Q into the air. In addition, the resistor emits thermal radiation T_{ER} , representing another means of escape for the energy. After some time interval has passed, the resistor reaches a constant temperature. At this time, the input of energy from the battery is balanced by the output of energy from the resistor by heat and radiation, and the resistor is a nonisolated system in steady state. Some electrical devices include *heat sinks*⁴ connected to parts of the circuit to prevent these parts from reaching dangerously high temperatures. Heat sinks are pieces of metal with many fins. Because the metal's high thermal conductivity provides a rapid transfer of energy by heat away from the hot component and the large number of fins provides a large surface area in contact with the air, energy can transfer by radiation and into the air by heat at a high rate.

Let's now investigate the rate at which the electric potential energy of the system decreases as the charge Q passes through the resistor:

$$\frac{dU}{dt} = \frac{d}{dt}(Q\Delta V) = \frac{dQ}{dt}\Delta V = I\Delta V$$

where I is the current in the circuit. The system regains this potential energy when the charge passes through the battery, at the expense of chemical energy in the battery. The rate at which the potential energy of the system decreases as the charge passes through the resistor is equal to the rate at which the system gains internal energy in the resistor. Therefore, the power P , representing the rate at which energy is delivered to the resistor, is

$$P = I\Delta V \quad (27.21)$$

We derived this result by considering a battery delivering energy to a resistor. Equation 27.21, however, can be used to calculate the power delivered by a voltage source to *any* device carrying a current I and having a potential difference ΔV between its terminals.

Using Equation 27.21 and $\Delta V = IR$ for a resistor, we can express the power delivered to the resistor in the alternative forms

$$P = I^2R = \frac{(\Delta V)^2}{R} \quad (27.22)$$

When I is expressed in amperes, ΔV in volts, and R in ohms, the SI unit of power is the watt, as it was in Chapter 8 in our discussion of mechanical power. The process by which energy is transformed to internal energy in a conductor of resistance R is often called *joule heating*;⁵ this transformation is also often referred to as an I^2R loss.

Pitfall Prevention 27.5

Charges Do Not Move All the Way Around a Circuit in a Short Time

In terms of understanding the energy transfer in a circuit, it is useful to *imagine* a charge moving all the way around the circuit even though it would take hours to do so.

Pitfall Prevention 27.6

Misconceptions About Current

Several common misconceptions are associated with current in a circuit like that in Figure 27.11. One is that current comes out of one terminal of the battery and is then “used up” as it passes through the resistor, leaving current in only one part of the circuit. The current is actually the same *everywhere* in the circuit. A related misconception has the current coming out of the resistor being smaller than that going in because some of the current is “used up.” Yet another misconception has current coming out of both terminals of the battery, in opposite directions, and then “clashing” in the resistor, delivering the energy in this manner. That is not the case; charges flow in the same rotational sense at *all* points in the circuit.

Pitfall Prevention 27.7

Energy Is Not “Dissipated” In some books, you may see Equation 27.22 described as the power “dissipated in” a resistor, suggesting that energy disappears. Instead, we say energy is “delivered to” a resistor.

⁴This usage is another misuse of the word *heat* that is ingrained in our common language.

⁵It is commonly called *joule heating* even though the process of heat does not occur when energy delivered to a resistor appears as internal energy. It is another example of incorrect usage of the word *heat* that has become entrenched in our language.

Figure 27.12 These power lines transfer energy from the electric company to homes and businesses. The energy is transferred at a very high voltage, possibly hundreds of thousands of volts in some cases. Even though it makes power lines very dangerous, the high voltage results in less loss of energy due to resistance in the wires.



When transporting energy by electricity through power lines (Fig. 27.12), you should not assume the lines have zero resistance. Real power lines do indeed have resistance, and power is delivered to the resistance of these wires. Utility companies seek to minimize the energy transformed to internal energy in the lines and maximize the energy delivered to the consumer. Because $P = I\Delta V$, the same amount of energy can be transported either at high currents and low potential differences or at low currents and high potential differences. Utility companies choose to transport energy at low currents and high potential differences primarily for economic reasons. Copper wire is very expensive, so it is cheaper to use high-resistance wire (that is, wire having a small cross-sectional area; see Eq. 27.10). Therefore, in the expression for the power delivered to a resistor, $P = I^2R$, the resistance of the wire is fixed at a relatively high value for economic considerations. The I^2R loss can be reduced by keeping the current I as low as possible, which means transferring the energy at a high voltage. In some instances, power is transported at potential differences as great as 765 kV. At the destination of the energy, the potential difference is usually reduced to 4 kV by a device called a *transformer*. Another transformer drops the potential difference to 240 V for use in your home. Of course, each time the potential difference decreases, the current increases by the same factor and the power remains the same. We shall discuss transformers in greater detail in Chapter 33.

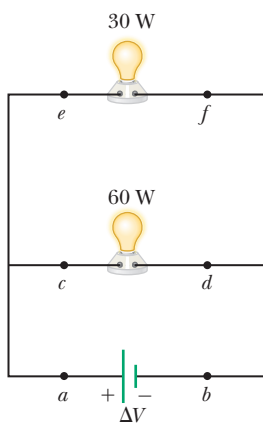

Figure 27.13 (Quick Quiz 27.5) Two lightbulbs connected across the same potential difference.

Quick Quiz 27.5 For the two lightbulbs shown in Figure 27.13, rank the current values at points a through f from greatest to least.

Example 27.4 Power in an Electric Heater

An electric heater is constructed by applying a potential difference of 120 V across a Nichrome wire that has a total resistance of $8.00\ \Omega$. Find the current carried by the wire and the power rating of the heater.

SOLUTION

Conceptualize As discussed in Example 27.2, Nichrome wire has high resistivity and is often used for heating elements in toasters, irons, and electric heaters. Therefore, we expect the power delivered to the wire to be relatively high.

Categorize We evaluate the power from Equation 27.22, so we categorize this example as a substitution problem.

Use Equation 27.7 to find the current in the wire:
$$I = \frac{\Delta V}{R} = \frac{120\ \text{V}}{8.00\ \Omega} = 15.0\ \text{A}$$

Find the power rating using the expression $P = I^2R$ from Equation 27.22:
$$P = I^2R = (15.0\ \text{A})^2(8.00\ \Omega) = 1.80 \times 10^3\ \text{W} = 1.80\ \text{kW}$$

WHAT IF? What if the heater were accidentally connected to a 240-V supply? (That is difficult to do because the shape and orientation of the metal contacts in 240-V plugs are different from those in 120-V plugs.) How would that affect the current carried by the heater and the power rating of the heater, assuming the resistance remains constant?

Answer If the applied potential difference were doubled, Equation 27.7 shows that the current would double. According to Equation 27.22, $P = (\Delta V)^2/R$, the power would be four times larger.

Example 27.5 Linking Electricity and Thermodynamics AM

An immersion heater must increase the temperature of 1.50 kg of water from 10.0°C to 50.0°C in 10.0 min while operating at 110 V.

(A) What is the required resistance of the heater?

SOLUTION

Conceptualize An immersion heater is a resistor that is inserted into a container of water. As energy is delivered to the immersion heater, raising its temperature, energy leaves the surface of the resistor by heat, going into the water. When the immersion heater reaches a constant temperature, the rate of energy delivered to the resistance by electrical transmission (T_{ET}) is equal to the rate of energy delivered by heat (Q) to the water.

Categorize This example allows us to link our new understanding of power in electricity with our experience with specific heat in thermodynamics (Chapter 20). The water is a *nonisolated system*. Its internal energy is rising because of energy transferred into the water by heat from the resistor, so Equation 8.2 reduces to $\Delta E_{int} = Q$. In our model, we assume the energy that enters the water from the heater remains in the water.

Analyze To simplify the analysis, let's ignore the initial period during which the temperature of the resistor increases and also ignore any variation of resistance with temperature. Therefore, we imagine a constant rate of energy transfer for the entire 10.0 min.

Set the rate of energy delivered to the resistor equal to the rate of energy Q entering the water by heat:

$$P = \frac{(\Delta V)^2}{R} = \frac{Q}{\Delta t}$$

Use Equation 20.4, $Q = mc \Delta T$, to relate the energy input by heat to the resulting temperature change of the water and solve for the resistance:

$$\frac{(\Delta V)^2}{R} = \frac{mc \Delta T}{\Delta t} \rightarrow R = \frac{(\Delta V)^2 \Delta t}{mc \Delta T}$$

Substitute the values given in the statement of the problem:

$$R = \frac{(110 \text{ V})^2(600 \text{ s})}{(1.50 \text{ kg})(4186 \text{ J/kg} \cdot ^\circ\text{C})(50.0^\circ\text{C} - 10.0^\circ\text{C})} = 28.9 \Omega$$

(B) Estimate the cost of heating the water.

SOLUTION

Multiply the power by the time interval to find the amount of energy transferred to the resistor:

$$T_{ET} = P \Delta t = \frac{(\Delta V)^2}{R} \Delta t = \frac{(110 \text{ V})^2}{28.9 \Omega} (10.0 \text{ min}) \left(\frac{1 \text{ h}}{60.0 \text{ min}} \right) \\ = 69.8 \text{ Wh} = 0.0698 \text{ kWh}$$

Find the cost knowing that energy is purchased at an estimated price of 11¢ per kilowatt-hour:

$$\text{Cost} = (0.0698 \text{ kWh})(\$0.11/\text{kWh}) = \$0.008 = 0.8\text{¢}$$

Finalize The cost to heat the water is very low, less than one cent. In reality, the cost is higher because some energy is transferred from the water into the surroundings by heat and electromagnetic radiation while its temperature is increasing. If you have electrical devices in your home with power ratings on them, use this power rating and an approximate time interval of use to estimate the cost for one use of the device.

Summary

Definitions

The electric **current** I in a conductor is defined as

$$I \equiv \frac{dQ}{dt} \quad (27.2)$$

where dQ is the charge that passes through a cross section of the conductor in a time interval dt . The SI unit of current is the **ampere** (A), where 1 A = 1 C/s.

continued

The **current density** J in a conductor is the current per unit area:

$$J \equiv \frac{I}{A} \quad (27.5)$$

The **resistance** R of a conductor is defined as

$$R \equiv \frac{\Delta V}{I} \quad (27.7)$$

where ΔV is the potential difference across the conductor and I is the current it carries. The SI unit of resistance is volts per ampere, which is defined to be 1 **ohm** (Ω); that is, $1 \Omega = 1 \text{ V/A}$.

Concepts and Principles

The average current in a conductor is related to the motion of the charge carriers through the relationship

$$I_{\text{avg}} = nqv_d A \quad (27.4)$$

where n is the density of charge carriers, q is the charge on each carrier, v_d is the drift speed, and A is the cross-sectional area of the conductor.

The current density in an ohmic conductor is proportional to the electric field according to the expression

$$J = \sigma E \quad (27.6)$$

The proportionality constant σ is called the **conductivity** of the material of which the conductor is made. The inverse of σ is known as **resistivity** ρ (that is, $\rho = 1/\sigma$). Equation 27.6 is known as **Ohm's law**, and a material is said to obey this law if the ratio of its current density to its applied electric field is a constant that is independent of the applied field.

For a uniform block of material of cross-sectional area A and length ℓ , the resistance over the length ℓ is

$$R = \rho \frac{\ell}{A} \quad (27.10)$$

where ρ is the resistivity of the material.

In a classical model of electrical conduction in metals, the electrons are treated as molecules of a gas. In the absence of an electric field, the average velocity of the electrons is zero. When an electric field is applied, the electrons move (on average) with a **drift velocity** \vec{v}_d that is opposite the electric field. The drift velocity is given by

$$\vec{v}_d = \frac{q\vec{E}}{m_e} \tau \quad (27.13)$$

where q is the electron's charge, m_e is the mass of the electron, and τ is the average time interval between electron-atom collisions. According to this model, the resistivity of the metal is

$$\rho = \frac{m_e}{nq^2\tau} \quad (27.16)$$

where n is the number of free electrons per unit volume.

The resistivity of a conductor varies approximately linearly with temperature according to the expression

$$\rho = \rho_0[1 + \alpha(T - T_0)] \quad (27.18)$$

where ρ_0 is the resistivity at some reference temperature T_0 and α is the **temperature coefficient of resistivity**.

If a potential difference ΔV is maintained across a circuit element, the **power**, or rate at which energy is supplied to the element, is

$$P = I\Delta V \quad (27.21)$$

Because the potential difference across a resistor is given by $\Delta V = IR$, we can express the power delivered to a resistor as

$$P = I^2 R = \frac{(\Delta V)^2}{R} \quad (27.22)$$

The energy delivered to a resistor by electrical transmission T_{ET} appears in the form of internal energy E_{int} in the resistor.

Objective Questions

1. denotes answer available in *Student Solutions Manual/Study Guide*

1. Car batteries are often rated in ampere-hours. Does this information designate the amount of (a) current, (b) power, (c) energy, (d) charge, or (e) potential the battery can supply?

2. Two wires A and B with circular cross sections are made of the same metal and have equal lengths, but the resistance of wire A is three times greater than that of wire B. (i) What is the ratio of the cross-sectional

- area of A to that of B? (a) 3 (b) $\sqrt{3}$ (c) 1 (d) $1/\sqrt{3}$ (e) $\frac{1}{3}$ (ii) What is the ratio of the radius of A to that of B? Choose from the same possibilities as in part (i).
- A cylindrical metal wire at room temperature is carrying electric current between its ends. One end is at potential $V_A = 50$ V, and the other end is at potential $V_B = 0$ V. Rank the following actions in terms of the change that each one separately would produce in the current from the greatest increase to the greatest decrease. In your ranking, note any cases of equality. (a) Make $V_A = 150$ V with $V_B = 0$ V. (b) Adjust V_A to triple the power with which the wire converts electrically transmitted energy into internal energy. (c) Double the radius of the wire. (d) Double the length of the wire. (e) Double the Celsius temperature of the wire.
 - A current-carrying ohmic metal wire has a cross-sectional area that gradually becomes smaller from one end of the wire to the other. The current has the same value for each section of the wire, so charge does not accumulate at any one point. (i) How does the drift speed vary along the wire as the area becomes smaller? (a) It increases. (b) It decreases. (c) It remains constant. (ii) How does the resistance per unit length vary along the wire as the area becomes smaller? Choose from the same possibilities as in part (i).
 - A potential difference of 1.00 V is maintained across a 10.0- Ω resistor for a period of 20.0 s. What total charge passes by a point in one of the wires connected to the resistor in this time interval? (a) 200 C (b) 20.0 C (c) 2.00 C (d) 0.005 00 C (e) 0.050 0 C
 - Three wires are made of copper having circular cross sections. Wire 1 has a length L and radius r . Wire 2 has a length L and radius $2r$. Wire 3 has a length $2L$ and radius $3r$. Which wire has the smallest resistance? (a) wire 1 (b) wire 2 (c) wire 3 (d) All have the same resistance. (e) Not enough information is given to answer the question.
 - A metal wire of resistance R is cut into three equal pieces that are then placed together side by side to form a new cable with a length equal to one-third the original length. What is the resistance of this new cable? (a) $\frac{1}{9}R$ (b) $\frac{1}{3}R$ (c) R (d) $3R$ (e) $9R$
 - A metal wire has a resistance of 10.0 Ω at a temperature of 20.0°C. If the same wire has a resistance of 10.6 Ω at 90.0°C, what is the resistance of this wire when its temperature is -20.0°C? (a) 0.700 Ω (b) 9.66 Ω (c) 10.3 Ω (d) 13.8 Ω (e) 6.59 Ω
 - The current-versus-voltage behavior of a certain electrical device is shown in Figure OQ27.9. When the potential difference across the device is 2 V, what is its resistance? (a) 1 Ω (b) $\frac{3}{4}$ Ω (c) $\frac{4}{3}$ Ω (d) undefined (e) none of those answers
 - Two conductors made of the same material are connected across the same potential difference. Conductor A has twice the diameter and twice the length of conductor B. What is the ratio of the power delivered to A to the power delivered to B? (a) 8 (b) 4 (c) 2 (d) 1 (e) $\frac{1}{2}$
 - Two conducting wires A and B of the same length and radius are connected across the same potential difference. Conductor A has twice the resistivity of conductor B. What is the ratio of the power delivered to A to the power delivered to B? (a) 2 (b) $\sqrt{2}$ (c) 1 (d) $1/\sqrt{2}$ (e) $\frac{1}{2}$
 - Two lightbulbs both operate on 120 V. One has a power of 25 W and the other 100 W. (i) Which lightbulb has higher resistance? (a) The dim 25-W lightbulb does. (b) The bright 100-W lightbulb does. (c) Both are the same. (ii) Which lightbulb carries more current? Choose from the same possibilities as in part (i).
 - Wire B has twice the length and twice the radius of wire A. Both wires are made from the same material. If wire A has a resistance R , what is the resistance of wire B? (a) $4R$ (b) $2R$ (c) R (d) $\frac{1}{2}R$ (e) $\frac{1}{4}R$

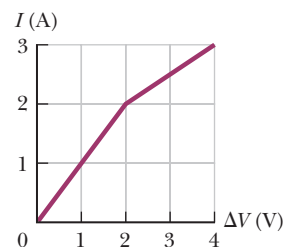

Figure OQ27.9

Conceptual Questions

1. denotes answer available in *Student Solutions Manual/Study Guide*

- If you were to design an electric heater using Nichrome wire as the heating element, what parameters of the wire could you vary to meet a specific power output such as 1 000 W?
- What factors affect the resistance of a conductor?
- When the potential difference across a certain conductor is doubled, the current is observed to increase by a factor of 3. What can you conclude about the conductor?
- Over the time interval after a difference in potential is applied between the ends of a wire, what would happen to the drift velocity of the electrons in a wire and to the current in the wire if the electrons could move freely without resistance through the wire?
- How does the resistance for copper and for silicon change with temperature? Why are the behaviors of these two materials different?
- Use the atomic theory of matter to explain why the resistance of a material should increase as its temperature increases.
- If charges flow very slowly through a metal, why does it not require several hours for a light to come on when you throw a switch?
- Newspaper articles often contain statements such as "10 000 volts of electricity surged through the victim's body." What is wrong with this statement?

Problems

WebAssign The problems found in this chapter may be assigned online in Enhanced WebAssign

1. straightforward; 2. intermediate; 3. challenging

1. full solution available in the *Student Solutions Manual/Study Guide*

AMT Analysis Model tutorial available in Enhanced WebAssign

GP Guided Problem

M Master It tutorial available in Enhanced WebAssign

W Watch It video solution available in Enhanced WebAssign

Section 27.1 Electric Current

AMT 1. A 200-km-long high-voltage transmission line 2.00 cm in diameter carries a steady current of 1 000 A. If the conductor is copper with a free charge density of 8.50×10^{28} electrons per cubic meter, how many years does it take one electron to travel the full length of the cable?

M 2. A small sphere that carries a charge q is whirled in a circle at the end of an insulating string. The angular frequency of revolution is ω . What average current does this revolving charge represent?

W 3. An aluminum wire having a cross-sectional area equal to $4.00 \times 10^{-6} \text{ m}^2$ carries a current of 5.00 A. The density of aluminum is 2.70 g/cm^3 . Assume each aluminum atom supplies one conduction electron per atom. Find the drift speed of the electrons in the wire.

AMT 4. In the Bohr model of the hydrogen atom (which will be covered in detail in Chapter 42), an electron in the lowest energy state moves at a speed of $2.19 \times 10^6 \text{ m/s}$ in a circular path of radius $5.29 \times 10^{-11} \text{ m}$. What is the effective current associated with this orbiting electron?

5. A proton beam in an accelerator carries a current of $125 \mu\text{A}$. If the beam is incident on a target, how many protons strike the target in a period of 23.0 s?

6. A copper wire has a circular cross section with a radius of 1.25 mm. (a) If the wire carries a current of 3.70 A, find the drift speed of the electrons in this wire. (b) All other things being equal, what happens to the drift speed in wires made of metal having a larger number of conduction electrons per atom than copper? Explain.

7. Suppose the current in a conductor decreases exponentially with time according to the equation $I(t) = I_0 e^{-t/\tau}$, where I_0 is the initial current (at $t = 0$) and τ is a constant having dimensions of time. Consider a fixed observation point within the conductor. (a) How much charge passes this point between $t = 0$ and $t = \tau$? (b) How much charge passes this point between $t = 0$ and $t = 10\tau$? (c) **What If?** How much charge passes this point between $t = 0$ and $t = \infty$?

W 8. Figure P27.8 represents a section of a conductor of nonuniform diameter carrying a current of $I = 5.00 \text{ A}$. The radius of cross-section A_1 is $r_1 = 0.400 \text{ cm}$. (a) What is the magnitude of the current density across A_1 ? The radius r_2 at A_2 is larger than the radius r_1 at A_1 .

(b) Is the current at A_2 larger, smaller, or the same? (c) Is the current density at A_2 larger, smaller, or the same? Assume $A_2 = 4A_1$. Specify the (d) radius, (e) current, and (f) current density at A_2 .

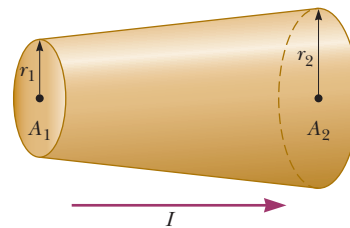

Figure P27.8

W 9. The quantity of charge q (in coulombs) that has passed through a surface of area 2.00 cm^2 varies with time according to the equation $q = 4t^3 + 5t + 6$, where t is in seconds. (a) What is the instantaneous current through the surface at $t = 1.00 \text{ s}$? (b) What is the value of the current density?

10. A Van de Graaff generator produces a beam of 2.00-MeV deuterons, which are heavy hydrogen nuclei containing a proton and a neutron. (a) If the beam current is $10.0 \mu\text{A}$, what is the average separation of the deuterons? (b) Is the electrical force of repulsion among them a significant factor in beam stability? Explain.

M 11. The electron beam emerging from a certain high-energy electron accelerator has a circular cross section of radius 1.00 mm. (a) The beam current is $8.00 \mu\text{A}$. Find the current density in the beam assuming it is uniform throughout. (b) The speed of the electrons is so close to the speed of light that their speed can be taken as 300 Mm/s with negligible error. Find the electron density in the beam. (c) Over what time interval does Avogadro's number of electrons emerge from the accelerator?

W 12. An electric current in a conductor varies with time according to the expression $I(t) = 100 \sin(120\pi t)$, where I is in amperes and t is in seconds. What is the total charge passing a given point in the conductor from $t = 0$ to $t = \frac{1}{240} \text{ s}$?

W 13. A teapot with a surface area of 700 cm^2 is to be plated with silver. It is attached to the negative electrode of an electrolytic cell containing silver nitrate (Ag^+NO_3^-). The cell is powered by a 12.0-V battery and has a

resistance of $1.80\ \Omega$. If the density of silver is $10.5 \times 10^3\ \text{kg/m}^3$, over what time interval does a 0.133-mm layer of silver build up on the teapot?

Section 27.2 Resistance

14. A lightbulb has a resistance of $240\ \Omega$ when operating with a potential difference of $120\ \text{V}$ across it. What is the current in the lightbulb?
15. A wire $50.0\ \text{m}$ long and $2.00\ \text{mm}$ in diameter is connected to a source with a potential difference of $9.11\ \text{V}$, and the current is found to be $36.0\ \text{A}$. Assume a temperature of 20.0°C and, using Table 27.2, identify the metal out of which the wire is made.
16. A 0.900-V potential difference is maintained across a 1.50-m length of tungsten wire that has a cross-sectional area of $0.600\ \text{mm}^2$. What is the current in the wire?
17. An electric heater carries a current of $13.5\ \text{A}$ when operating at a voltage of $120\ \text{V}$. What is the resistance of the heater?
18. Aluminum and copper wires of equal length are found to have the same resistance. What is the ratio of their radii?
19. Suppose you wish to fabricate a uniform wire from $1.00\ \text{g}$ of copper. If the wire is to have a resistance of $R = 0.500\ \Omega$ and all the copper is to be used, what must be (a) the length and (b) the diameter of this wire?
20. Suppose you wish to fabricate a uniform wire from a mass m of a metal with density ρ_m and resistivity ρ . If the wire is to have a resistance of R and all the metal is to be used, what must be (a) the length and (b) the diameter of this wire?
21. A portion of Nichrome wire of radius $2.50\ \text{mm}$ is to be used in winding a heating coil. If the coil must draw a current of $9.25\ \text{A}$ when a voltage of $120\ \text{V}$ is applied across its ends, find (a) the required resistance of the coil and (b) the length of wire you must use to wind the coil.

Section 27.3 A Model for Electrical Conduction

22. If the current carried by a conductor is doubled, what happens to (a) the charge carrier density, (b) the current density, (c) the electron drift velocity, and (d) the average time interval between collisions?
23. A current density of $6.00 \times 10^{-13}\ \text{A/m}^2$ exists in the atmosphere at a location where the electric field is $100\ \text{V/m}$. Calculate the electrical conductivity of the Earth's atmosphere in this region.
24. An iron wire has a cross-sectional area equal to $5.00 \times 10^{-6}\ \text{m}^2$. Carry out the following steps to determine the drift speed of the conduction electrons in the wire if it carries a current of $30.0\ \text{A}$. (a) How many kilograms are there in 1.00 mole of iron? (b) Starting with the density of iron and the result of part (a), compute the molar density of iron (the number of moles of iron per cubic meter). (c) Calculate the number density of

iron atoms using Avogadro's number. (d) Obtain the number density of conduction electrons given that there are two conduction electrons per iron atom. (e) Calculate the drift speed of conduction electrons in this wire.

25. If the magnitude of the drift velocity of free electrons in a copper wire is $7.84 \times 10^{-4}\ \text{m/s}$, what is the electric field in the conductor?

Section 27.4 Resistance and Temperature

26. A certain lightbulb has a tungsten filament with a resistance of $19.0\ \Omega$ when at 20.0°C and $140\ \Omega$ when hot. Assume the resistivity of tungsten varies linearly with temperature even over the large temperature range involved here. Find the temperature of the hot filament.
27. What is the fractional change in the resistance of an iron filament when its temperature changes from 25.0°C to 50.0°C ?
28. While taking photographs in Death Valley on a day when the temperature is 58.0°C , Bill Hiker finds that a certain voltage applied to a copper wire produces a current of $1.00\ \text{A}$. Bill then travels to Antarctica and applies the same voltage to the same wire. What current does he register there if the temperature is -88.0°C ? Assume that no change occurs in the wire's shape and size.
29. If a certain silver wire has a resistance of $6.00\ \Omega$ at 20.0°C , what resistance will it have at 34.0°C ?
30. Plethysmographs are devices used for measuring changes in the volume of internal organs or limbs. In one form of this device, a rubber capillary tube with an inside diameter of $1.00\ \text{mm}$ is filled with mercury at 20.0°C . The resistance of the mercury is measured with the aid of electrodes sealed into the ends of the tube. If $100\ \text{cm}$ of the tube is wound in a helix around a patient's upper arm, the blood flow during a heart-beat causes the arm to expand, stretching the length of the tube by $0.0400\ \text{cm}$. From this observation and assuming cylindrical symmetry, you can find the change in volume of the arm, which gives an indication of blood flow. Taking the resistivity of mercury to be $9.58 \times 10^{-7}\ \Omega \cdot \text{m}$, calculate (a) the resistance of the mercury and (b) the fractional change in resistance during the heartbeat. *Hint:* The fraction by which the cross-sectional area of the mercury column decreases is the fraction by which the length increases because the volume of mercury is constant.
31. (a) A 34.5-m length of copper wire at 20.0°C has a radius of $0.25\ \text{mm}$. If a potential difference of $9.00\ \text{V}$ is applied across the length of the wire, determine the current in the wire. (b) If the wire is heated to 30.0°C while the 9.00-V potential difference is maintained, what is the resulting current in the wire?
32. An engineer needs a resistor with a zero overall temperature coefficient of resistance at 20.0°C . She designs a pair of circular cylinders, one of carbon and one of Nichrome as shown in Figure P27.32 (page 828). The

device must have an overall resistance of $R_1 + R_2 = 10.0\ \Omega$ independent of temperature and a uniform radius of $r = 1.50\ \text{mm}$. Ignore thermal expansion of the cylinders and assume both are always at the same temperature.

(a) Can she meet the design goal with this method?
 (b) If so, state what you can determine about the lengths ℓ_1 and ℓ_2 of each segment. If not, explain.



Figure P27.32

- 33.** An aluminum wire with a diameter of $0.100\ \text{mm}$ has a uniform electric field of $0.200\ \text{V/m}$ imposed along its entire length. The temperature of the wire is 50.0°C . Assume one free electron per atom. (a) Use the information in Table 27.2 to determine the resistivity of aluminum at this temperature. (b) What is the current density in the wire? (c) What is the total current in the wire? (d) What is the drift speed of the conduction electrons? (e) What potential difference must exist between the ends of a 2.00-m length of the wire to produce the stated electric field?
- 34. Review.** An aluminum rod has a resistance of $1.23\ \Omega$ at 20.0°C . Calculate the resistance of the rod at 120°C by accounting for the changes in both the resistivity and the dimensions of the rod. The coefficient of linear expansion for aluminum is $2.40 \times 10^{-6}\ (\text{C}^\circ)^{-1}$.
- 35.** At what temperature will aluminum have a resistivity that is three times the resistivity copper has at room temperature?

Section 27.6 Electrical Power

- 36.** Assume that global lightning on the Earth constitutes a constant current of $1.00\ \text{kA}$ between the ground and an atmospheric layer at potential $300\ \text{kV}$. (a) Find the power of terrestrial lightning. (b) For comparison, find the power of sunlight falling on the Earth. Sunlight has an intensity of $1\ 370\ \text{W/m}^2$ above the atmosphere. Sunlight falls perpendicularly on the circular projected area that the Earth presents to the Sun.
- 37.** In a hydroelectric installation, a turbine delivers $1\ 500\ \text{hp}$ to a generator, which in turn transfers 80.0% of the mechanical energy out by electrical transmission. Under these conditions, what current does the generator deliver at a terminal potential difference of $2\ 000\ \text{V}$?
- 38.** A Van de Graaff generator (see Fig. 25.23) is operating so that the potential difference between the high-potential electrode \textcircled{B} and the charging needles at \textcircled{A} is $15.0\ \text{kV}$. Calculate the power required to drive the belt against electrical forces at an instant when the effective current delivered to the high-potential electrode is $500\ \mu\text{A}$.
- 39.** A certain waffle iron is rated at $1.00\ \text{kW}$ when connected to a 120-V source. (a) What current does the waffle iron carry? (b) What is its resistance?
- 40.** The potential difference across a resting neuron in the human body is about $75.0\ \text{mV}$ and carries a current of about $0.200\ \text{mA}$. How much power does the neuron release?
- 41.** Suppose your portable DVD player draws a current of $350\ \text{mA}$ at $6.00\ \text{V}$. How much power does the player require?
- 42. Review.** A well-insulated electric water heater warms **AMT** $109\ \text{kg}$ of water from 20.0°C to 49.0°C in $25.0\ \text{min}$. **M** Find the resistance of its heating element, which is connected across a 240-V potential difference.
- 43.** A 100-W lightbulb connected to a 120-V source experiences a voltage surge that produces $140\ \text{V}$ for a moment. By what percentage does its power output increase? Assume its resistance does not change.
- 44.** The cost of energy delivered to residences by electrical transmission varies from $\$0.070/\text{kWh}$ to $\$0.258/\text{kWh}$ throughout the United States; $\$0.110/\text{kWh}$ is the average value. At this average price, calculate the cost of (a) leaving a 40.0-W porch light on for two weeks while you are on vacation, (b) making a piece of dark toast in $3.00\ \text{min}$ with a 970-W toaster, and (c) drying a load of clothes in $40.0\ \text{min}$ in a $5.20 \times 10^3\text{-W}$ dryer.
- 45.** Batteries are rated in terms of ampere-hours ($\text{A} \cdot \text{h}$). **W** For example, a battery that can produce a current of $2.00\ \text{A}$ for $3.00\ \text{h}$ is rated at $6.00\ \text{A} \cdot \text{h}$. (a) What is the total energy, in kilowatt-hours, stored in a 12.0-V battery rated at $55.0\ \text{A} \cdot \text{h}$? (b) At $\$0.110$ per kilowatt-hour, what is the value of the electricity produced by this battery?
- 46.** Residential building codes typically require the use **W** of 12-gauge copper wire (diameter $0.205\ \text{cm}$) for wiring receptacles. Such circuits carry currents as large as $20.0\ \text{A}$. If a wire of smaller diameter (with a higher gauge number) carried that much current, the wire could rise to a high temperature and cause a fire. (a) Calculate the rate at which internal energy is produced in $1.00\ \text{m}$ of 12-gauge copper wire carrying $20.0\ \text{A}$. (b) **What If?** Repeat the calculation for a 12-gauge aluminum wire. (c) Explain whether a 12-gauge aluminum wire would be as safe as a copper wire.
- 47.** Assuming the cost of energy from the electric company **M** is $\$0.110/\text{kWh}$, compute the cost per day of operating a lamp that draws a current of $1.70\ \text{A}$ from a 110-V line.
- 48.** An 11.0-W energy-efficient fluorescent lightbulb is designed to produce the same illumination as a conventional 40.0-W incandescent lightbulb. Assuming a cost of $\$0.110/\text{kWh}$ for energy from the electric company, how much money does the user of the energy-efficient bulb save during $100\ \text{h}$ of use?
- 49.** A coil of Nichrome wire is $25.0\ \text{m}$ long. The wire has a diameter of $0.400\ \text{mm}$ and is at 20.0°C . If it carries a current of $0.500\ \text{A}$, what are (a) the magnitude of the electric field in the wire and (b) the power delivered to it? (c) **What If?** If the temperature is increased to 340°C and the potential difference across the wire remains constant, what is the power delivered?
- 50. Review.** A rechargeable battery of mass $15.0\ \text{g}$ delivers an average current of $18.0\ \text{mA}$ to a portable DVD player at $1.60\ \text{V}$ for $2.40\ \text{h}$ before the battery must be

- recharged. The recharger maintains a potential difference of 2.30 V across the battery and delivers a charging current of 13.5 mA for 4.20 h. (a) What is the efficiency of the battery as an energy storage device? (b) How much internal energy is produced in the battery during one charge–discharge cycle? (c) If the battery is surrounded by ideal thermal insulation and has an effective specific heat of $975 \text{ J/kg} \cdot ^\circ\text{C}$, by how much will its temperature increase during the cycle?
51. A 500-W heating coil designed to operate from 110 V is made of Nichrome wire 0.500 mm in diameter. (a) Assuming the resistivity of the Nichrome remains constant at its 20.0°C value, find the length of wire used. (b) **What If?** Now consider the variation of resistivity with temperature. What power is delivered to the coil of part (a) when it is warmed to 1200°C ?
52. *Why is the following situation impossible?* A politician is decrying wasteful uses of energy and decides to focus on energy used to operate plug-in electric clocks in the United States. He estimates there are 270 million of these clocks, approximately one clock for each person in the population. The clocks transform energy taken in by electrical transmission at the average rate 2.50 W. The politician gives a speech in which he complains that, at today's electrical rates, the nation is losing \$100 million every year to operate these clocks.
53. **M** A certain toaster has a heating element made of Nichrome wire. When the toaster is first connected to a 120-V source (and the wire is at a temperature of 20.0°C), the initial current is 1.80 A. The current decreases as the heating element warms up. When the toaster reaches its final operating temperature, the current is 1.53 A. (a) Find the power delivered to the toaster when it is at its operating temperature. (b) What is the final temperature of the heating element?
54. Make an order-of-magnitude estimate of the cost of one person's routine use of a handheld hair dryer for 1 year. If you do not use a hair dryer yourself, observe or interview someone who does. State the quantities you estimate and their values.
55. **Review.** The heating element of an electric coffee maker operates at 120 V and carries a current of 2.00 A. Assuming the water absorbs all the energy delivered to the resistor, calculate the time interval during which the temperature of 0.500 kg of water rises from room temperature (23.0°C) to the boiling point.
56. A 120-V motor has mechanical power output of 2.50 hp. It is 90.0% efficient in converting power that it takes in by electrical transmission into mechanical power. (a) Find the current in the motor. (b) Find the energy delivered to the motor by electrical transmission in 3.00 h of operation. (c) If the electric company charges $\$0.110/\text{kWh}$, what does it cost to run the motor for 3.00 h?
- 48 W of power when connected across a 20-V battery. What length of wire is required?
58. Determine the temperature at which the resistance of an aluminum wire will be twice its value at 20.0°C . Assume its coefficient of resistivity remains constant.
59. A car owner forgets to turn off the headlights of his car while it is parked in his garage. If the 12.0-V battery in his car is rated at $90.0 \text{ A} \cdot \text{h}$ and each headlight requires 36.0 W of power, how long will it take the battery to completely discharge?
60. Lightbulb A is marked "25 W 120 V," and lightbulb B is marked "100 W 120 V." These labels mean that each lightbulb has its respective power delivered to it when it is connected to a constant 120-V source. (a) Find the resistance of each lightbulb. (b) During what time interval does 1.00 C pass into lightbulb A? (c) Is this charge different upon its exit versus its entry into the lightbulb? Explain. (d) In what time interval does 1.00 J pass into lightbulb A? (e) By what mechanisms does this energy enter and exit the lightbulb? Explain. (f) Find the cost of running lightbulb A continuously for 30.0 days, assuming the electric company sells its product at $\$0.110$ per kWh.
61. One wire in a high-voltage transmission line carries **W** 1 000 A starting at 700 kV for a distance of 100 mi. If the resistance in the wire is $0.500 \Omega/\text{mi}$, what is the power loss due to the resistance of the wire?
62. An experiment is conducted to measure the electrical resistivity of Nichrome in the form of wires with different lengths and cross-sectional areas. For one set of measurements, a student uses 30-gauge wire, which has a cross-sectional area of $7.30 \times 10^{-8} \text{ m}^2$. The student measures the potential difference across the wire and the current in the wire with a voltmeter and an ammeter, respectively. (a) For each set of measurements given in the table taken on wires of three different lengths, calculate the resistance of the wires and the corresponding values of the resistivity. (b) What is the average value of the resistivity? (c) Explain how this value compares with the value given in Table 27.2.

L (m)	ΔV (V)	I (A)	R (Ω)	ρ ($\Omega \cdot \text{m}$)
0.540	5.22	0.72		
1.028	5.82	0.414		
1.543	5.94	0.281		

63. A charge Q is placed on a capacitor of capacitance C . The capacitor is connected into the circuit shown in Figure P27.63, with an open switch, a resistor, and an initially uncharged capacitor of capacitance $3C$. The

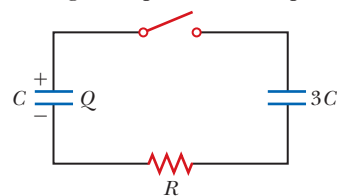

Figure P27.63

Additional Problems

57. A particular wire has a resistivity of $3.0 \times 10^{-8} \Omega \cdot \text{m}$ and a cross-sectional area of $4.0 \times 10^{-6} \text{ m}^2$. A length of this wire is to be used as a resistor that will receive

- switch is then closed, and the circuit comes to equilibrium. In terms of Q and C , find (a) the final potential difference between the plates of each capacitor, (b) the charge on each capacitor, and (c) the final energy stored in each capacitor. (d) Find the internal energy appearing in the resistor.
- 64. Review.** An office worker uses an immersion heater to warm 250 g of water in a light, covered, insulated cup from 20.0°C to 100°C in 4.00 min. The heater is a Nichrome resistance wire connected to a 120-V power supply. Assume the wire is at 100°C throughout the 4.00-min time interval. (a) Specify a relationship between a diameter and a length that the wire can have. (b) Can it be made from less than 0.500 cm³ of Nichrome?
- 65.** An x-ray tube used for cancer therapy operates at 4.00 MV with electrons constituting a beam current of 25.0 mA striking a metal target. Nearly all the power in the beam is transferred to a stream of water flowing through holes drilled in the target. What rate of flow, in kilograms per second, is needed if the rise in temperature of the water is not to exceed 50.0°C?
- 66.** **AMT** An all-electric car (not a hybrid) is designed to run from a bank of 12.0-V batteries with total energy storage of 2.00×10^7 J. If the electric motor draws 8.00 kW as the car moves at a steady speed of 20.0 m/s, (a) what is the current delivered to the motor? (b) How far can the car travel before it is “out of juice”?
- 67.** A straight, cylindrical wire lying along the x axis has a length of 0.500 m and a diameter of 0.200 mm. It is made of a material described by Ohm’s law with a resistivity of $\rho = 4.00 \times 10^{-8} \Omega \cdot \text{m}$. Assume a potential of 4.00 V is maintained at the left end of the wire at $x = 0$. Also assume $V = 0$ at $x = 0.500$ m. Find (a) the magnitude and direction of the electric field in the wire, (b) the resistance of the wire, (c) the magnitude and direction of the electric current in the wire, and (d) the current density in the wire. (e) Show that $E = \rho j$.
- 68.** A straight, cylindrical wire lying along the x axis has a length L and a diameter d . It is made of a material described by Ohm’s law with a resistivity ρ . Assume potential V is maintained at the left end of the wire at $x = 0$. Also assume the potential is zero at $x = L$. In terms of L , d , V , ρ , and physical constants, derive expressions for (a) the magnitude and direction of the electric field in the wire, (b) the resistance of the wire, (c) the magnitude and direction of the electric current in the wire, and (d) the current density in the wire. (e) Show that $E = \rho j$.
- 69.** **W** An electric utility company supplies a customer’s house from the main power lines (120 V) with two copper wires, each of which is 50.0 m long and has a resistance of 0.108 Ω per 300 m. (a) Find the potential difference at the customer’s house for a load current of 110 A. For this load current, find (b) the power delivered to the customer and (c) the rate at which internal energy is produced in the copper wires.
- 70.** The strain in a wire can be monitored and computed by measuring the resistance of the wire. Let L_i represent the original length of the wire, A_i its original cross-sectional area, $R_i = \rho L_i/A_i$ the original resistance between its ends, and $\delta = \Delta L/L_i = (L - L_i)/L_i$ the strain resulting from the application of tension. Assume the resistivity and the volume of the wire do not change as the wire stretches. (a) Show that the resistance between the ends of the wire under strain is given by $R = R_i(1 + 2\delta + \delta^2)$. (b) If the assumptions are precisely true, is this result exact or approximate? Explain your answer.
- 71.** An oceanographer is studying how the ion concentration in seawater depends on depth. She makes a measurement by lowering into the water a pair of concentric metallic cylinders (Fig. P27.71) at the end of a cable and taking data to determine the resistance between these electrodes as a function of depth. The water between the two cylinders forms a cylindrical shell of inner radius r_a , outer radius r_b , and length L much larger than r_b . The scientist applies a potential difference ΔV between the inner and outer surfaces, producing an outward radial current I . Let ρ represent the resistivity of the water. (a) Find the resistance of the water between the cylinders in terms of L , ρ , r_a , and r_b . (b) Express the resistivity of the water in terms of the measured quantities L , r_a , r_b , ΔV , and I .

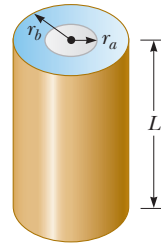

Figure P27.71

- 72.** Why is the following situation impossible? An inquisitive physics student takes a 100-W incandescent lightbulb out of its socket and measures its resistance with an ohmmeter. He measures a value of 10.5 Ω . He is able to connect an ammeter to the lightbulb socket to correctly measure the current drawn by the bulb while operating. Inserting the bulb back into the socket and operating the bulb from a 120-V source, he measures the current to be 11.4 A.
- 73.** The temperature coefficients of resistivity α in Table 27.2 are based on a reference temperature T_0 of 20.0°C. Suppose the coefficients were given the symbol α' and were based on a T_0 of 0°C. What would the coefficient α' for silver be? *Note:* The coefficient α satisfies $\rho = \rho_0[1 + \alpha(T - T_0)]$, where ρ_0 is the resistivity of the material at $T_0 = 20.0^\circ\text{C}$. The coefficient α' must satisfy the expression $\rho = \rho'_0[1 + \alpha'T]$, where ρ'_0 is the resistivity of the material at 0°C.
- 74.** A close analogy exists between the flow of energy by heat because of a temperature difference (see Section 20.7) and the flow of electric charge because of a

potential difference. In a metal, energy dQ and electrical charge dq are both transported by free electrons. Consequently, a good electrical conductor is usually a good thermal conductor as well. Consider a thin conducting slab of thickness dx , area A , and electrical conductivity σ , with a potential difference dV between opposite faces. (a) Show that the current $I = dq/dt$ is given by the equation on the left:

Charge conduction Thermal conduction

$$\frac{dq}{dt} = \sigma A \left| \frac{dV}{dx} \right| \qquad \frac{dQ}{dt} = kA \left| \frac{dT}{dx} \right|$$

In the analogous thermal conduction equation on the right (Eq. 20.15), the rate dQ/dt of energy flow by heat (in SI units of joules per second) is due to a temperature gradient dT/dx in a material of thermal conductivity k . (b) State analogous rules relating the direction of the electric current to the change in potential and relating the direction of energy flow to the change in temperature.

- 75. Review.** When a straight wire is warmed, its resistance is given by $R = R_0[1 + \alpha(T - T_0)]$ according to Equation 27.20, where α is the temperature coefficient of resistivity. This expression needs to be modified if we include the change in dimensions of the wire due to thermal expansion. For a copper wire of radius 0.100 0 mm and length 2.000 m, find its resistance at 100.0°C, including the effects of both thermal expansion and temperature variation of resistivity. Assume the coefficients are known to four significant figures.
- 76. Review.** When a straight wire is warmed, its resistance is given by $R = R_0[1 + \alpha(T - T_0)]$ according to Equation 27.20, where α is the temperature coefficient of resistivity. This expression needs to be modified if we include the change in dimensions of the wire due to thermal expansion. Find a more precise expression for the resistance, one that includes the effects of changes in the dimensions of the wire when it is warmed. Your final expression should be in terms of R_0 , T , T_0 , the temperature coefficient of resistivity α , and the coefficient of linear expansion α' .
- 77. Review.** A parallel-plate capacitor consists of square plates of edge length ℓ that are separated by a distance d , where $d \ll \ell$. A potential difference ΔV is maintained between the plates. A material of dielectric constant κ fills half the space between the plates. The dielectric slab is withdrawn from the capacitor as shown in Figure P27.77. (a) Find the capacitance when

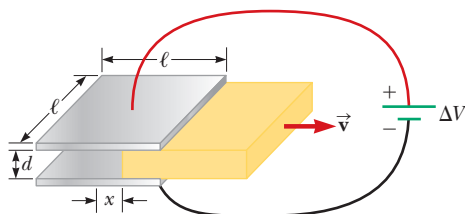

Figure P27.77

the left edge of the dielectric is at a distance x from the center of the capacitor. (b) If the dielectric is removed at a constant speed v , what is the current in the circuit as the dielectric is being withdrawn?

- 78.** The dielectric material between the plates of a parallel-plate capacitor always has some nonzero conductivity σ . Let A represent the area of each plate and d the distance between them. Let κ represent the dielectric constant of the material. (a) Show that the resistance R and the capacitance C of the capacitor are related by

$$RC = \frac{\kappa \epsilon_0}{\sigma}$$

- (b) Find the resistance between the plates of a 14.0-nF capacitor with a fused quartz dielectric.
- 79.** Gold is the most ductile of all metals. For example, one gram of gold can be drawn into a wire 2.40 km long. The density of gold is $19.3 \times 10^3 \text{ kg/m}^3$, and its resistivity is $2.44 \times 10^{-8} \Omega \cdot \text{m}$. What is the resistance of such a wire at 20.0°C?

- 80.** The current–voltage characteristic curve for a semiconductor diode as a function of temperature T is given by

$$I = I_0(e^{e\Delta V/k_B T} - 1)$$

Here the first symbol e represents Euler's number, the base of natural logarithms. The second e is the magnitude of the electron charge, the k_B stands for Boltzmann's constant, and T is the absolute temperature. (a) Set up a spreadsheet to calculate I and $R = \Delta V/I$ for $\Delta V = 0.400 \text{ V}$ to 0.600 V in increments of 0.005 V . Assume $I_0 = 1.00 \text{ nA}$. (b) Plot R versus ΔV for $T = 280 \text{ K}$, 300 K , and 320 K .

- 81.** The potential difference across the filament of a light-bulb is maintained at a constant value while equilibrium temperature is being reached. The steady-state current in the bulb is only one-tenth of the current drawn by the bulb when it is first turned on. If the temperature coefficient of resistivity for the bulb at 20.0°C is $0.004 50 (\text{°C})^{-1}$ and the resistance increases linearly with increasing temperature, what is the final operating temperature of the filament?

Challenge Problems

- 82.** A more general definition of the temperature coefficient of resistivity is

$$\alpha = \frac{1}{\rho} \frac{d\rho}{dT}$$

where ρ is the resistivity at temperature T . (a) Assuming α is constant, show that

$$\rho = \rho_0 e^{\alpha(T - T_0)}$$

where ρ_0 is the resistivity at temperature T_0 . (b) Using the series expansion $e^x \approx 1 + x$ for $x \ll 1$, show that the resistivity is given approximately by the expression

$$\rho = \rho_0 [1 + \alpha(T - T_0)] \quad \text{for } \alpha(T - T_0) \ll 1$$

- 83.** A spherical shell with inner radius r_a and outer radius r_b is formed from a material of resistivity ρ . It carries

current radially, with uniform density in all directions. Show that its resistance is

$$R = \frac{\rho}{4\pi} \left(\frac{1}{r_a} - \frac{1}{r_b} \right)$$

- 84.** Material with uniform resistivity ρ is formed into a wedge as shown in Figure P27.84. Show that the resistance between face A and face B of this wedge is

$$R = \rho \frac{L}{w(y_2 - y_1)} \ln \frac{y_2}{y_1}$$

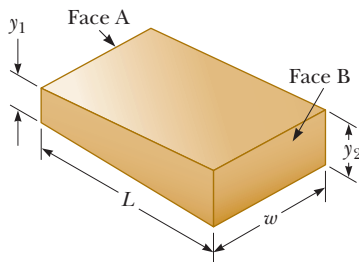

Figure P27.84

- 85.** A material of resistivity ρ is formed into the shape of a truncated cone of height h as shown in Figure P27.85. The bottom end has radius b , and the top end has radius a . Assume the current is distributed uniformly over any circular cross section of the cone so that the current density does not depend on radial position. (The current density does vary with position along the axis of the cone.) Show that the resistance between the two ends is

$$R = \frac{\rho}{\pi} \left(\frac{h}{ab} \right)$$

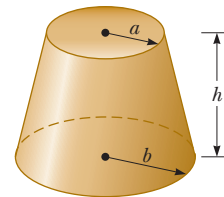
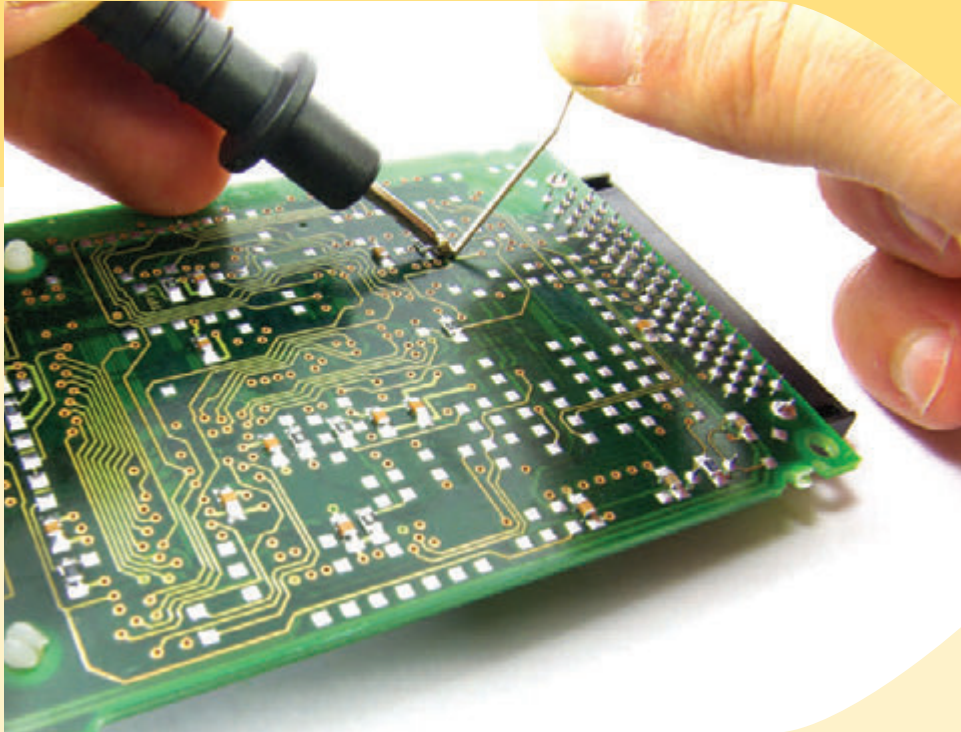

Figure P27.85

Direct-Current Circuits

CHAPTER

28



- 28.1 Electromotive Force
- 28.2 Resistors in Series and Parallel
- 28.3 Kirchhoff's Rules
- 28.4 RC Circuits
- 28.5 Household Wiring and Electrical Safety

In this chapter, we analyze simple electric circuits that contain batteries, resistors, and capacitors in various combinations. Some circuits contain resistors that can be combined using simple rules. The analysis of more complicated circuits is simplified using *Kirchhoff's rules*, which follow from the laws of conservation of energy and conservation of electric charge for isolated systems. Most of the circuits analyzed are assumed to be in *steady state*, which means that currents in the circuit are constant in magnitude and direction. A current that is constant in direction is called a *direct current* (DC). We will study *alternating current* (AC), in which the current changes direction periodically, in Chapter 33. Finally, we discuss electrical circuits in the home.

A technician repairs a connection on a circuit board from a computer. In our lives today, we use various items containing electric circuits, including many with circuit boards much smaller than the board shown in the photograph. These include handheld game players, cell phones, and digital cameras. In this chapter, we study simple types of circuits and learn how to analyze them.

(Trombax/Shutterstock.com)

28.1 Electromotive Force

In Section 27.6, we discussed a circuit in which a battery produces a current. We will generally use a battery as a source of energy for circuits in our discussion. Because the potential difference at the battery terminals is constant in a particular circuit, the current in the circuit is constant in magnitude and direction and is called **direct current**. A battery is called either a *source of electromotive force* or, more commonly, a *source of emf*. (The phrase *electromotive force* is an unfortunate historical term, describing not a force, but rather a potential difference in volts.) The **emf \mathcal{E}** of a battery is **the maximum possible voltage the battery can provide between its terminals**. You can think of a source of emf as a “charge pump.” When an electric potential difference exists between two points, the source moves charges “uphill” from the lower potential to the higher.

We shall generally assume the connecting wires in a circuit have no resistance. The positive terminal of a battery is at a higher potential than the negative terminal.

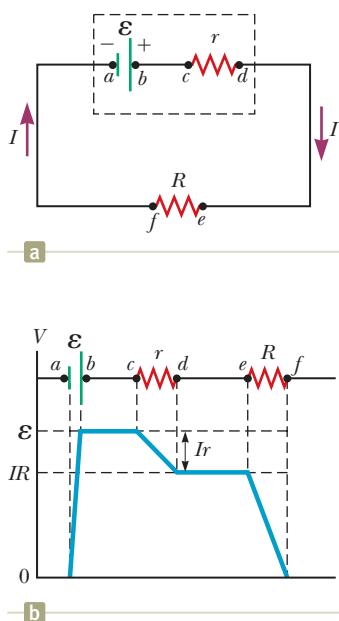

Figure 28.1 (a) Circuit diagram of a source of emf \mathcal{E} (in this case, a battery), of internal resistance r , connected to an external resistor of resistance R . (b) Graphical representation showing how the electric potential changes as the circuit in (a) is traversed clockwise.

Because a real battery is made of matter, there is resistance to the flow of charge within the battery. This resistance is called **internal resistance** r . For an idealized battery with zero internal resistance, the potential difference across the battery (called its *terminal voltage*) equals its emf. For a real battery, however, the terminal voltage is *not* equal to the emf for a battery in a circuit in which there is a current. To understand why, consider the circuit diagram in Figure 28.1a. We model the battery as shown in the diagram; it is represented by the dashed rectangle containing an ideal, resistance-free emf \mathcal{E} in series with an internal resistance r . A resistor of resistance R is connected across the terminals of the battery. Now imagine moving through the battery from a to d and measuring the electric potential at various locations. Passing from the negative terminal to the positive terminal, the potential increases by an amount \mathcal{E} . As we move through the resistance r , however, the potential *decreases* by an amount Ir , where I is the current in the circuit. Therefore, the terminal voltage of the battery $\Delta V = V_d - V_a$ is

$$\Delta V = \mathcal{E} - Ir \quad (28.1)$$

From this expression, notice that \mathcal{E} is equivalent to the **open-circuit voltage**, that is, the terminal voltage when the current is zero. The emf is the voltage labeled on a battery; for example, the emf of a D cell is 1.5 V. The actual potential difference between a battery's terminals depends on the current in the battery as described by Equation 28.1. Figure 28.1b is a graphical representation of the changes in electric potential as the circuit is traversed in the clockwise direction.

Figure 28.1a shows that the terminal voltage ΔV must equal the potential difference across the external resistance R , often called the **load resistance**. The load resistor might be a simple resistive circuit element as in Figure 28.1a, or it could be the resistance of some electrical device (such as a toaster, electric heater, or lightbulb) connected to the battery (or, in the case of household devices, to the wall outlet). The resistor represents a *load* on the battery because the battery must supply energy to operate the device containing the resistance. The potential difference across the load resistance is $\Delta V = IR$. Combining this expression with Equation 28.1, we see that

$$\mathcal{E} = IR + Ir \quad (28.2)$$

Figure 28.1a shows a graphical representation of this equation. Solving for the current gives

$$I = \frac{\mathcal{E}}{R + r} \quad (28.3)$$

Equation 28.3 shows that the current in this simple circuit depends on both the load resistance R external to the battery and the internal resistance r . If R is much greater than r , as it is in many real-world circuits, we can neglect r .

Multiplying Equation 28.2 by the current I in the circuit gives

$$I\mathcal{E} = I^2R + I^2r \quad (28.4)$$

Equation 28.4 indicates that because power $P = I\Delta V$ (see Eq. 27.21), the total power output $I\mathcal{E}$ associated with the emf of the battery is delivered to the external load resistance in the amount I^2R and to the internal resistance in the amount I^2r .

Quick Quiz 28.1 To maximize the percentage of the power from the emf of a battery that is delivered to a device external to the battery, what should the internal resistance of the battery be? (a) It should be as low as possible. (b) It should be as high as possible. (c) The percentage does not depend on the internal resistance.

Pitfall Prevention 28.1

What Is Constant in a Battery?

It is a common misconception that a battery is a source of constant current. Equation 28.3 shows that is not true. The current in the circuit depends on the resistance R connected to the battery. It is also not true that a battery is a source of constant terminal voltage as shown by Equation 28.1. **A battery is a source of constant emf.**

Example 28.1

Terminal Voltage of a Battery

A battery has an emf of 12.0 V and an internal resistance of $0.050 \, \Omega$. Its terminals are connected to a load resistance of $3.00 \, \Omega$.

▶ 28.1 continued

(A) Find the current in the circuit and the terminal voltage of the battery.

SOLUTION

Conceptualize Study Figure 28.1a, which shows a circuit consistent with the problem statement. The battery delivers energy to the load resistor.

Categorize This example involves simple calculations from this section, so we categorize it as a substitution problem.

Use Equation 28.3 to find the current in the circuit:
$$I = \frac{\mathcal{E}}{R + r} = \frac{12.0 \text{ V}}{3.00 \Omega + 0.0500 \Omega} = 3.93 \text{ A}$$

Use Equation 28.1 to find the terminal voltage:
$$\Delta V = \mathcal{E} - Ir = 12.0 \text{ V} - (3.93 \text{ A})(0.0500 \Omega) = 11.8 \text{ V}$$

To check this result, calculate the voltage across the load resistance R :
$$\Delta V = IR = (3.93 \text{ A})(3.00 \Omega) = 11.8 \text{ V}$$

(B) Calculate the power delivered to the load resistor, the power delivered to the internal resistance of the battery, and the power delivered by the battery.

SOLUTION

Use Equation 27.22 to find the power delivered to the load resistor:
$$P_R = I^2R = (3.93 \text{ A})^2(3.00 \Omega) = 46.3 \text{ W}$$

Find the power delivered to the internal resistance:
$$P_r = I^2r = (3.93 \text{ A})^2(0.0500 \Omega) = 0.772 \text{ W}$$

Find the power delivered by the battery by adding these quantities:
$$P = P_R + P_r = 46.3 \text{ W} + 0.772 \text{ W} = 47.1 \text{ W}$$

WHAT IF? As a battery ages, its internal resistance increases. Suppose the internal resistance of this battery rises to 2.00Ω toward the end of its useful life. How does that alter the battery's ability to deliver energy?

Answer Let's connect the same $3.00\text{-}\Omega$ load resistor to the battery.

Find the new current in the battery:
$$I = \frac{\mathcal{E}}{R + r} = \frac{12.0 \text{ V}}{3.00 \Omega + 2.00 \Omega} = 2.40 \text{ A}$$

Find the new terminal voltage:
$$\Delta V = \mathcal{E} - Ir = 12.0 \text{ V} - (2.40 \text{ A})(2.00 \Omega) = 7.2 \text{ V}$$

Find the new powers delivered to the load resistor and internal resistance:
$$P_R = I^2R = (2.40 \text{ A})^2(3.00 \Omega) = 17.3 \text{ W}$$

$$P_r = I^2r = (2.40 \text{ A})^2(2.00 \Omega) = 11.5 \text{ W}$$

In this situation, the terminal voltage is only 60% of the emf. Notice that 40% of the power from the battery is delivered to the internal resistance when r is 2.00Ω . When r is 0.0500Ω as in part (B), this percentage is only 1.6%. Consequently, even though the emf remains fixed, the increasing internal resistance of the battery significantly reduces the battery's ability to deliver energy to an external load.

Example 28.2 Matching the Load

Find the load resistance R for which the maximum power is delivered to the load resistance in Figure 28.1a.

SOLUTION

Conceptualize Think about varying the load resistance in Figure 28.1a and the effect on the power delivered to the load resistance. When R is large, there is very little current, so the power I^2R delivered to the load resistor is small.

continued

28.2 continued

When R is small, let's say $R \ll r$, the current is large and the power delivered to the internal resistance is $I^2 r \gg I^2 R$. Therefore, the power delivered to the load resistor is small compared to that delivered to the internal resistance. For some intermediate value of the resistance R , the power must maximize.

Categorize We categorize this example as an analysis problem because we must undertake a procedure to maximize the power. The circuit is the same as that in Example 28.1. The load resistance R in this case, however, is a variable.

Analyze Find the power delivered to the load resistance using Equation 27.22, with I given by Equation 28.3:

Differentiate the power with respect to the load resistance R and set the derivative equal to zero to maximize the power:

Solve for R :

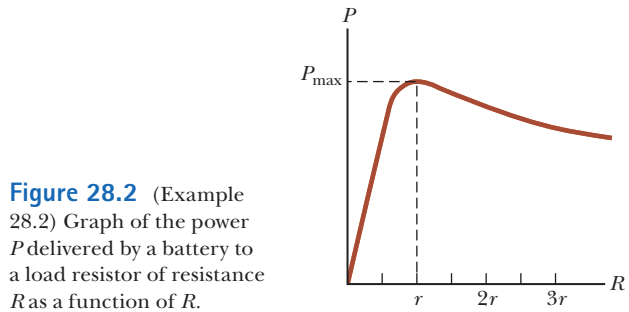

Figure 28.2 (Example 28.2) Graph of the power P delivered by a battery to a load resistor of resistance R as a function of R .

$$(1) \quad P = I^2 R = \frac{\mathcal{E}^2 R}{(R + r)^2}$$

$$\frac{dP}{dR} = \frac{d}{dR} \left[\frac{\mathcal{E}^2 R}{(R + r)^2} \right] = \frac{d}{dR} [\mathcal{E}^2 R (R + r)^{-2}] = 0$$

$$[\mathcal{E}^2 (R + r)^{-2}] + [\mathcal{E}^2 R (-2)(R + r)^{-3}] = 0$$

$$\frac{\mathcal{E}^2 (R + r)}{(R + r)^3} - \frac{2\mathcal{E}^2 R}{(R + r)^3} = \frac{\mathcal{E}^2 (r - R)}{(R + r)^3} = 0$$

$$R = r$$

Finalize To check this result, let's plot P versus R as in Figure 28.2. The graph shows that P reaches a maximum value at $R = r$. Equation (1) shows that this maximum value is $P_{\max} = \mathcal{E}^2/4r$.

28.2 Resistors in Series and Parallel

When two or more resistors are connected together as are the incandescent lightbulbs in Figure 28.3a, they are said to be in a **series combination**. Figure 28.3b is the circuit diagram for the lightbulbs, shown as resistors, and the battery. What if you wanted to replace the series combination with a single resistor that would draw the same current from the battery? What would be its value? In a series connection, if an amount of charge Q exits resistor R_1 , charge Q must also enter the second resistor R_2 . Otherwise, charge would accumulate on the wire between the resistors. Therefore, the same amount of charge passes through both resistors in a given time interval and the currents are the same in both resistors:

$$I = I_1 = I_2$$

where I is the current leaving the battery, I_1 is the current in resistor R_1 , and I_2 is the current in resistor R_2 .

The potential difference applied across the series combination of resistors divides between the resistors. In Figure 28.3b, because the voltage drop¹ from a to b equals $I_1 R_1$ and the voltage drop from b to c equals $I_2 R_2$, the voltage drop from a to c is

$$\Delta V = \Delta V_1 + \Delta V_2 = I_1 R_1 + I_2 R_2$$

The potential difference across the battery is also applied to the **equivalent resistance** R_{eq} in Figure 28.3c:

$$\Delta V = I R_{\text{eq}}$$

¹The term *voltage drop* is synonymous with a decrease in electric potential across a resistor. It is often used by individuals working with electric circuits.

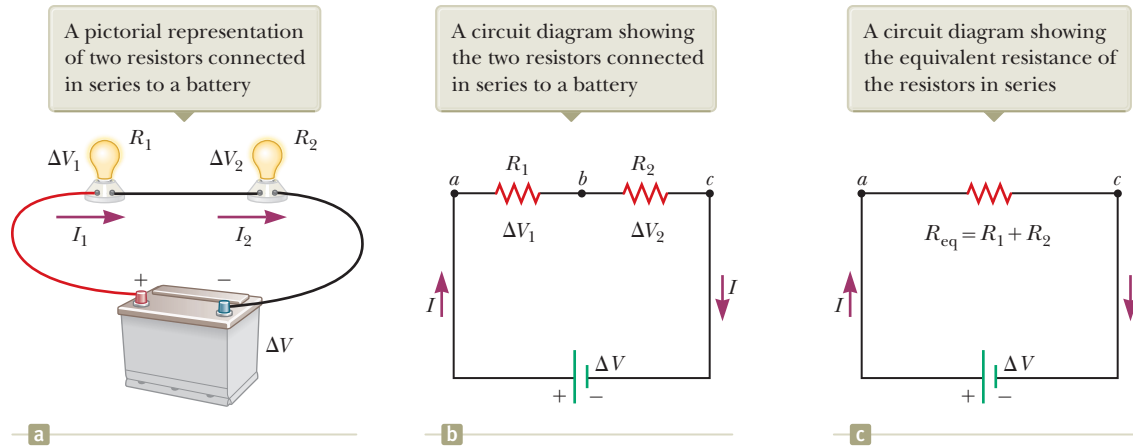

Figure 28.3 Two lightbulbs with resistances R_1 and R_2 connected in series. All three diagrams are equivalent.

where the equivalent resistance has the same effect on the circuit as the series combination because it results in the same current I in the battery. Combining these equations for ΔV gives

$$IR_{\text{eq}} = I_1R_1 + I_2R_2 \rightarrow R_{\text{eq}} = R_1 + R_2 \quad (28.5)$$

where we have canceled the currents I , I_1 , and I_2 because they are all the same. We see that we can replace the two resistors in series with a single equivalent resistance whose value is the *sum* of the individual resistances.

The equivalent resistance of three or more resistors connected in series is

$$R_{\text{eq}} = R_1 + R_2 + R_3 + \dots \quad (28.6)$$

This relationship indicates that the equivalent resistance of a series combination of resistors is the numerical sum of the individual resistances and is always greater than any individual resistance.

Looking back at Equation 28.3, we see that the denominator of the right-hand side is the simple algebraic sum of the external and internal resistances. That is consistent with the internal and external resistances being in series in Figure 28.1a.

If the filament of one lightbulb in Figure 28.3 were to fail, the circuit would no longer be complete (resulting in an open-circuit condition) and the second lightbulb would also go out. This fact is a general feature of a series circuit: if one device in the series creates an open circuit, all devices are inoperative.

Quick Quiz 28.2 With the switch in the circuit of Figure 28.4a closed, there is no current in R_2 because the current has an alternate zero-resistance path through the switch. There is current in R_1 , and this current is measured with the ammeter (a device for measuring current) at the bottom of the circuit. If the switch is opened (Fig. 28.4b), there is current in R_2 . What happens to the reading on the ammeter when the switch is opened? (a) The reading goes up. (b) The reading goes down. (c) The reading does not change.

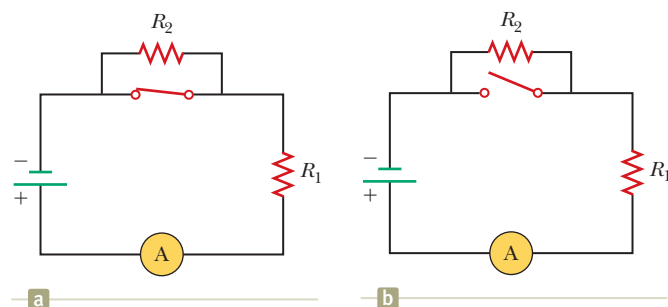

Figure 28.4 (Quick Quiz 28.2) What happens when the switch is opened?

◀ The equivalent resistance of a series combination of resistors

Pitfall Prevention 28.2

Lightbulbs Don't Burn We will describe the end of the life of an incandescent lightbulb by saying *the filament fails* rather than by saying the lightbulb “burns out.” The word *burn* suggests a combustion process, which is not what occurs in a lightbulb. The failure of a lightbulb results from the slow sublimation of tungsten from the very hot filament over the life of the lightbulb. The filament eventually becomes very thin because of this process. The mechanical stress from a sudden temperature increase when the lightbulb is turned on causes the thin filament to break.

Pitfall Prevention 28.3

Local and Global Changes A *local change in one part of a circuit may result in a global change throughout the circuit*. For example, if a single resistor is changed in a circuit containing several resistors and batteries, the currents in all resistors and batteries, the terminal voltages of all batteries, and the voltages across all resistors may change as a result.

Figure 28.5 Two lightbulbs with resistances R_1 and R_2 connected in parallel. All three diagrams are equivalent.

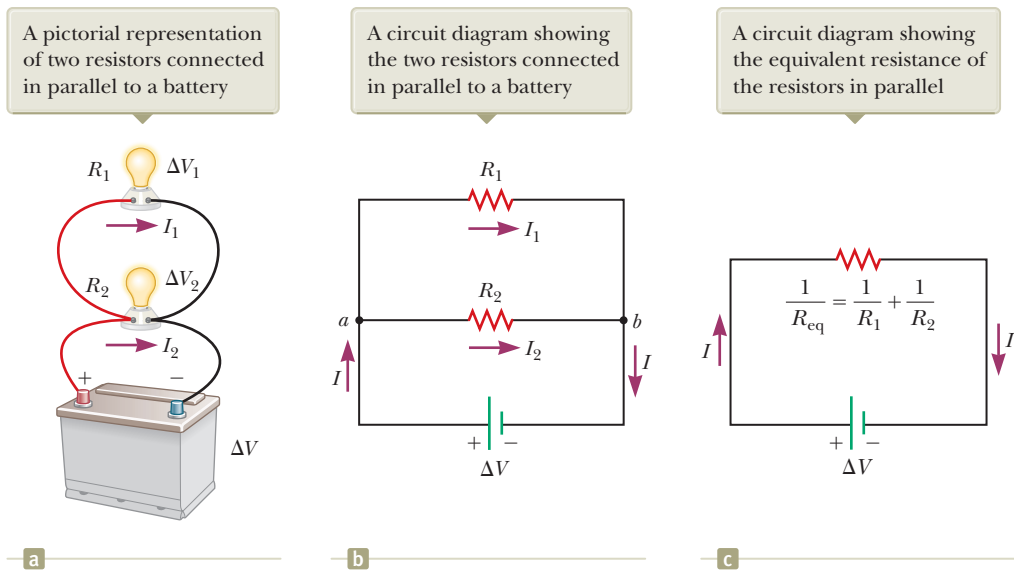

Pitfall Prevention 28.4

Current Does Not Take the Path of Least Resistance You may have heard the phrase “current takes the path of least resistance” (or similar wording) in reference to a parallel combination of current paths such that there are two or more paths for the current to take. Such wording is incorrect. The current takes *all* paths. Those paths with lower resistance have larger currents, but even very high resistance paths carry *some* of the current. In theory, if current has a choice between a zero-resistance path and a finite resistance path, all the current takes the path of zero resistance; a path with zero resistance, however, is an idealization.

Now consider two resistors in a **parallel combination** as shown in Figure 28.5. As with the series combination, what is the value of the single resistor that could replace the combination and draw the same current from the battery? Notice that both resistors are connected directly across the terminals of the battery. Therefore, the potential differences across the resistors are the same:

$$\Delta V = \Delta V_1 = \Delta V_2$$

where ΔV is the terminal voltage of the battery.

When charges reach point a in Figure 28.5b, they split into two parts, with some going toward R_1 and the rest going toward R_2 . A **junction** is any such point in a circuit where a current can split. This split results in less current in each individual resistor than the current leaving the battery. Because electric charge is conserved, the current I that enters point a must equal the total current leaving that point:

$$I = I_1 + I_2 = \frac{\Delta V_1}{R_1} + \frac{\Delta V_2}{R_2}$$

where I_1 is the current in R_1 and I_2 is the current in R_2 .

The current in the **equivalent resistance** R_{eq} in Figure 28.5c is

$$I = \frac{\Delta V}{R_{\text{eq}}}$$

where the equivalent resistance has the same effect on the circuit as the two resistors in parallel; that is, the equivalent resistance draws the same current I from the battery. Combining these equations for I , we see that the equivalent resistance of two resistors in parallel is given by

$$\frac{\Delta V}{R_{\text{eq}}} = \frac{\Delta V_1}{R_1} + \frac{\Delta V_2}{R_2} \rightarrow \frac{1}{R_{\text{eq}}} = \frac{1}{R_1} + \frac{1}{R_2} \quad (28.7)$$

where we have canceled ΔV , ΔV_1 , and ΔV_2 because they are all the same.

An extension of this analysis to three or more resistors in parallel gives

$$\frac{1}{R_{\text{eq}}} = \frac{1}{R_1} + \frac{1}{R_2} + \frac{1}{R_3} + \cdots \quad (28.8)$$

This expression shows that the inverse of the equivalent resistance of two or more resistors in a parallel combination is equal to the sum of the inverses of the indi-

The equivalent resistance of a parallel combination of resistors

vidual resistances. Furthermore, the equivalent resistance is always less than the smallest resistance in the group.

Household circuits are always wired such that the appliances are connected in parallel. Each device operates independently of the others so that if one is switched off, the others remain on. In addition, in this type of connection, all the devices operate on the same voltage.

Let's consider two examples of practical applications of series and parallel circuits. Figure 28.6 illustrates how a three-way incandescent lightbulb is constructed to provide three levels of light intensity.² The socket of the lamp is equipped with a three-way switch for selecting different light intensities. The lightbulb contains two filaments. When the lamp is connected to a 120-V source, one filament receives 100 W of power and the other receives 75 W. The three light intensities are made possible by applying the 120 V to one filament alone, to the other filament alone, or to the two filaments in parallel. When switch S_1 is closed and switch S_2 is opened, current exists only in the 75-W filament. When switch S_1 is open and switch S_2 is closed, current exists only in the 100-W filament. When both switches are closed, current exists in both filaments and the total power is 175 W.

If the filaments were connected in series and one of them were to break, no charges could pass through the lightbulb and it would not glow, regardless of the switch position. If, however, the filaments were connected in parallel and one of them (for example, the 75-W filament) were to break, the lightbulb would continue to glow in two of the switch positions because current exists in the other (100-W) filament.

As a second example, consider strings of incandescent lights that are used for many ornamental purposes such as decorating Christmas trees. Over the years, both parallel and series connections have been used for strings of lights. Because series-wired lightbulbs operate with less energy per bulb and at a lower temperature, they are safer than parallel-wired lightbulbs for indoor Christmas-tree use. If, however, the filament of a single lightbulb in a series-wired string were to fail (or if the lightbulb were removed from its socket), all the lights on the string would go out. The popularity of series-wired light strings diminished because troubleshooting a failed lightbulb is a tedious, time-consuming chore that involves trial-and-error substitution of a good lightbulb in each socket along the string until the defective one is found.

In a parallel-wired string, each lightbulb operates at 120 V. By design, the lightbulbs are brighter and hotter than those on a series-wired string. As a result, they are inherently more dangerous (more likely to start a fire, for instance), but if one lightbulb in a parallel-wired string fails or is removed, the rest of the lightbulbs continue to glow.

To prevent the failure of one lightbulb from causing the entire string to go out, a new design was developed for so-called miniature lights wired in series. When the filament breaks in one of these miniature lightbulbs, the break in the filament represents the largest resistance in the series, much larger than that of the intact filaments. As a result, most of the applied 120 V appears across the lightbulb with the broken filament. Inside the lightbulb, a small jumper loop covered by an insulating material is wrapped around the filament leads. When the filament fails and 120 V appears across the lightbulb, an arc burns the insulation on the jumper and connects the filament leads. This connection now completes the circuit through the lightbulb even though its filament is no longer active (Fig. 28.7, page 840).

When a lightbulb fails, the resistance across its terminals is reduced to almost zero because of the alternate jumper connection mentioned in the preceding paragraph. All the other lightbulbs not only stay on, but they glow more brightly because

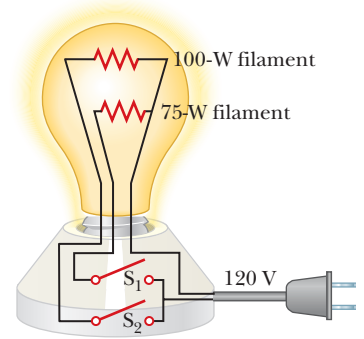
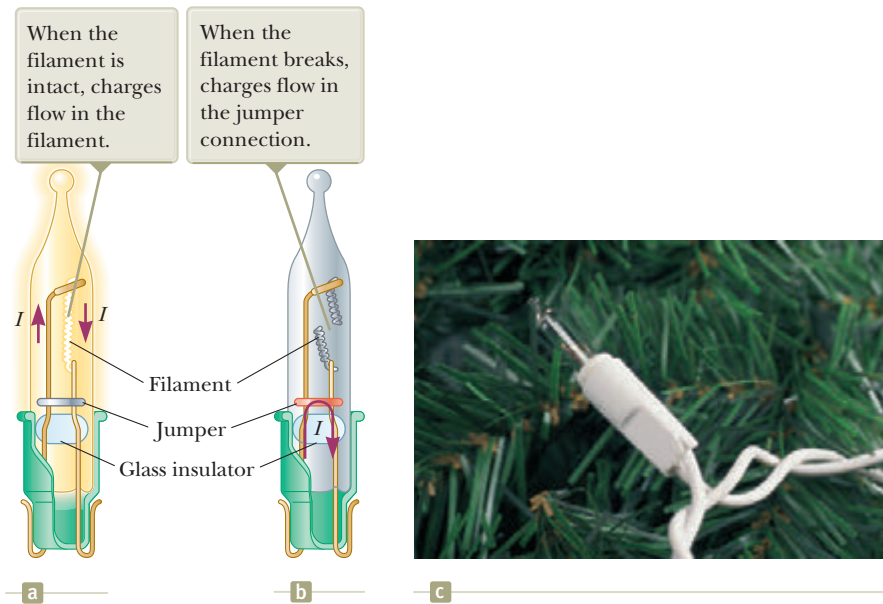

Figure 28.6 A three-way incandescent lightbulb.

²The three-way lightbulb and other household devices actually operate on alternating current (AC), to be introduced in Chapter 33.

Figure 28.7 (a) Schematic diagram of a modern “miniature” incandescent holiday lightbulb, with a jumper connection to provide a current path if the filament breaks. (b) A holiday lightbulb with a broken filament. (c) A Christmas-tree lightbulb.



© Cengage Learning/George Semple

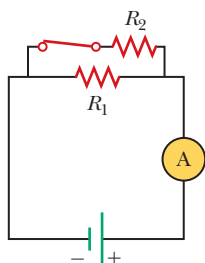
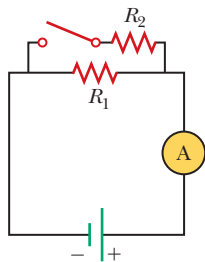

Figure 28.8 (Quick Quiz 28.3) What happens when the switch is closed?

the total resistance of the string is reduced and consequently the current in each remaining lightbulb increases. Each lightbulb operates at a slightly higher temperature than before. As more lightbulbs fail, the current keeps rising, the filament of each remaining lightbulb operates at a higher temperature, and the lifetime of the lightbulb is reduced. For this reason, you should check for failed (nonglowing) lightbulbs in such a series-wired string and replace them as soon as possible, thereby maximizing the lifetimes of all the lightbulbs.

Quick Quiz 28.3 With the switch in the circuit of Figure 28.8a open, there is no current in R_2 . There is current in R_1 , however, and it is measured with the ammeter at the right side of the circuit. If the switch is closed (Fig. 28.8b), there is current in R_2 . What happens to the reading on the ammeter when the switch is closed? (a) The reading increases. (b) The reading decreases. (c) The reading does not change.

Quick Quiz 28.4 Consider the following choices: (a) increases, (b) decreases, (c) remains the same. From these choices, choose the best answer for the following situations. (i) In Figure 28.3, a third resistor is added in series with the first two. What happens to the current in the battery? (ii) What happens to the terminal voltage of the battery? (iii) In Figure 28.5, a third resistor is added in parallel with the first two. What happens to the current in the battery? (iv) What happens to the terminal voltage of the battery?

Conceptual Example 28.3

Landscape Lights

A homeowner wishes to install low-voltage landscape lighting in his back yard. To save money, he purchases inexpensive 18-gauge cable, which has a relatively high resistance per unit length. This cable consists of two side-by-side wires separated by insulation, like the cord on an appliance. He runs a 200-foot length of this cable from the power supply to the farthest point at which he plans to position a light fixture. He attaches light fixtures across the two wires on the cable at 10-foot intervals so that the light fixtures are in parallel. Because of the cable's resistance, the brightness of the lightbulbs in the fixtures is not as desired. Which of the following problems does the homeowner have? (a) All the lightbulbs glow equally less brightly than they would if lower-resistance cable had been used. (b) The brightness of the lightbulbs decreases as you move farther from the power supply.

28.3 continued

SOLUTION

A circuit diagram for the system appears in Figure 28.9. The horizontal resistors with letter subscripts (such as R_A) represent the resistance of the wires in the cable between the light fixtures, and the vertical resistors with number subscripts (such as R_1) represent the resistance of the light fixtures themselves. Part of the terminal voltage of the power supply is dropped across resistors R_A and R_B . Therefore, the voltage across light fixture R_1 is less than the terminal voltage. There is a further voltage drop across resistors R_C and R_D . Consequently, the voltage across light fixture R_2 is smaller than that across R_1 . This pattern continues down the line of light fixtures, so the correct choice is (b). Each successive light fixture has a smaller voltage across it and glows less brightly than the one before.

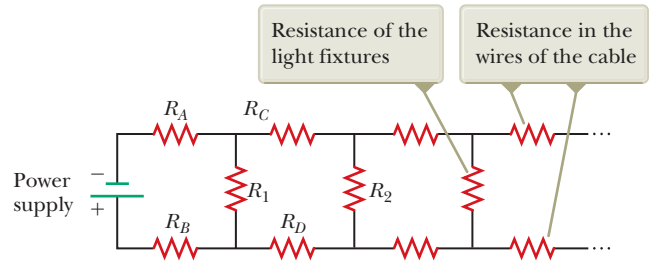

Figure 28.9 (Conceptual Example 28.3) The circuit diagram for a set of landscape light fixtures connected in parallel across the two wires of a two-wire cable.

Example 28.4 Find the Equivalent Resistance

Four resistors are connected as shown in Figure 28.10a.

(A) Find the equivalent resistance between points a and c .

SOLUTION

Conceptualize Imagine charges flowing into and through this combination from the left. All charges must pass from a to b through the first two resistors, but the charges split at b into two different paths when encountering the combination of the $6.0\text{-}\Omega$ and the $3.0\text{-}\Omega$ resistors.

Categorize Because of the simple nature of the combination of resistors in Figure 28.10, we categorize this example as one for which we can use the rules for series and parallel combinations of resistors.

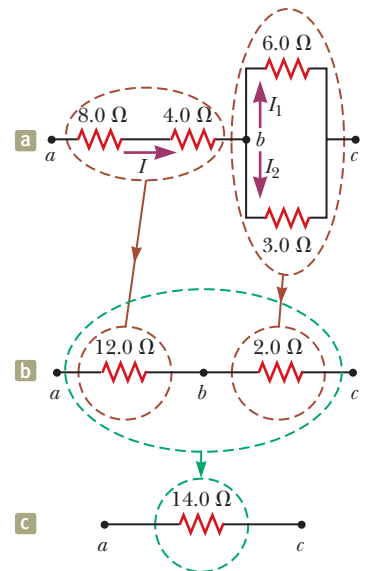

Figure 28.10 (Example 28.4) The original network of resistors is reduced to a single equivalent resistance.

Analyze The combination of resistors can be reduced in steps as shown in Figure 28.10.

Find the equivalent resistance between a and b of the $8.0\text{-}\Omega$ and $4.0\text{-}\Omega$ resistors, which are in series (left-hand red-brown circles):

$$R_{\text{eq}} = 8.0\ \Omega + 4.0\ \Omega = 12.0\ \Omega$$

Find the equivalent resistance between b and c of the $6.0\text{-}\Omega$ and $3.0\text{-}\Omega$ resistors, which are in parallel (right-hand red-brown circles):

$$\frac{1}{R_{\text{eq}}} = \frac{1}{6.0\ \Omega} + \frac{1}{3.0\ \Omega} = \frac{3}{6.0\ \Omega}$$

$$R_{\text{eq}} = \frac{6.0\ \Omega}{3} = 2.0\ \Omega$$

The circuit of equivalent resistances now looks like Figure 28.10b. The $12.0\text{-}\Omega$ and $2.0\text{-}\Omega$ resistors are in series (green circles). Find the equivalent resistance from a to c :

$$R_{\text{eq}} = 12.0\ \Omega + 2.0\ \Omega = 14.0\ \Omega$$

This resistance is that of the single equivalent resistor in Figure 28.10c.

(B) What is the current in each resistor if a potential difference of 42 V is maintained between a and c ?

continued

28.4 continued

SOLUTION

The currents in the 8.0- Ω and 4.0- Ω resistors are the same because they are in series. In addition, they carry the same current that would exist in the 14.0- Ω equivalent resistor subject to the 42-V potential difference.

Use Equation 27.7 ($R = \Delta V/I$) and the result from part (A) to find the current in the 8.0- Ω and 4.0- Ω resistors:

$$I = \frac{\Delta V_{ac}}{R_{eq}} = \frac{42 \text{ V}}{14.0 \Omega} = 3.0 \text{ A}$$

Set the voltages across the resistors in parallel in Figure 28.10a equal to find a relationship between the currents:

$$\Delta V_1 = \Delta V_2 \rightarrow (6.0 \Omega)I_1 = (3.0 \Omega)I_2 \rightarrow I_2 = 2I_1$$

Use $I_1 + I_2 = 3.0 \text{ A}$ to find I_1 :

$$I_1 + I_2 = 3.0 \text{ A} \rightarrow I_1 + 2I_1 = 3.0 \text{ A} \rightarrow I_1 = 1.0 \text{ A}$$

Find I_2 :

$$I_2 = 2I_1 = 2(1.0 \text{ A}) = 2.0 \text{ A}$$

Finalize As a final check of our results, note that $\Delta V_{bc} = (6.0 \Omega)I_1 = (3.0 \Omega)I_2 = 6.0 \text{ V}$ and $\Delta V_{ab} = (12.0 \Omega)I = 36 \text{ V}$; therefore, $\Delta V_{ac} = \Delta V_{ab} + \Delta V_{bc} = 42 \text{ V}$, as it must.

Example 28.5 Three Resistors in Parallel

Three resistors are connected in parallel as shown in Figure 28.11a. A potential difference of 18.0 V is maintained between points a and b .

(A) Calculate the equivalent resistance of the circuit.

SOLUTION

Conceptualize Figure 28.11a shows that we are dealing with a simple parallel combination of three resistors. Notice that the current I splits into three currents I_1 , I_2 , and I_3 in the three resistors.

Categorize This problem can be solved with rules developed in this section, so we categorize it as a substitution problem. Because the three resistors are connected in parallel, we can use the rule for resistors in parallel, Equation 28.8, to evaluate the equivalent resistance.

Use Equation 28.8 to find R_{eq} :

$$\frac{1}{R_{eq}} = \frac{1}{3.00 \Omega} + \frac{1}{6.00 \Omega} + \frac{1}{9.00 \Omega} = \frac{11}{18.0}$$

$$R_{eq} = \frac{18.0 \Omega}{11} = 1.64 \Omega$$

(B) Find the current in each resistor.

SOLUTION

The potential difference across each resistor is 18.0 V. Apply the relationship $\Delta V = IR$ to find the currents:

$$I_1 = \frac{\Delta V}{R_1} = \frac{18.0 \text{ V}}{3.00 \Omega} = 6.00 \text{ A}$$

$$I_2 = \frac{\Delta V}{R_2} = \frac{18.0 \text{ V}}{6.00 \Omega} = 3.00 \text{ A}$$

$$I_3 = \frac{\Delta V}{R_3} = \frac{18.0 \text{ V}}{9.00 \Omega} = 2.00 \text{ A}$$

(C) Calculate the power delivered to each resistor and the total power delivered to the combination of resistors.

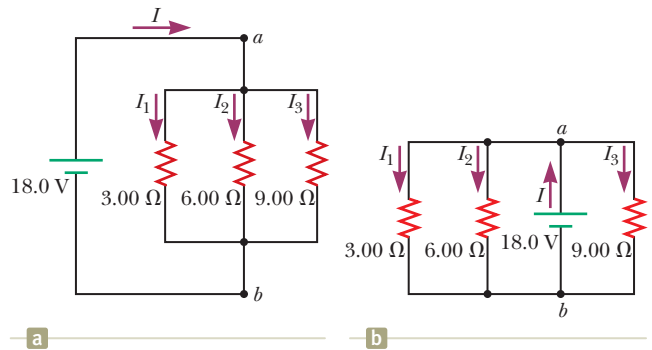

Figure 28.11 (Example 28.5) (a) Three resistors connected in parallel. The voltage across each resistor is 18.0 V. (b) Another circuit with three resistors and a battery. Is it equivalent to the circuit in (a)?

► 28.5 continued

SOLUTION

Apply the relationship $P = I^2R$ to each resistor using the currents calculated in part (B):

$$3.00\text{-}\Omega: P_1 = I_1^2R_1 = (6.00\text{ A})^2(3.00\ \Omega) = 108\text{ W}$$

$$6.00\text{-}\Omega: P_2 = I_2^2R_2 = (3.00\text{ A})^2(6.00\ \Omega) = 54\text{ W}$$

$$9.00\text{-}\Omega: P_3 = I_3^2R_3 = (2.00\text{ A})^2(9.00\ \Omega) = 36\text{ W}$$

These results show that the smallest resistor receives the most power. Summing the three quantities gives a total power of 198 W. We could have calculated this final result from part (A) by considering the equivalent resistance as follows: $P = (\Delta V)^2/R_{\text{eq}} = (18.0\text{ V})^2/1.64\ \Omega = 198\text{ W}$.

WHAT IF? What if the circuit were as shown in Figure 28.11b instead of as in Figure 28.11a? How would that affect the calculation?

Answer There would be no effect on the calculation. The physical placement of the battery is not important. Only the electrical arrangement is important. In Figure 28.11b, the battery still maintains a potential difference of 18.0 V between points *a* and *b*, so the two circuits in the figure are electrically identical.

28.3 Kirchhoff's Rules

As we saw in the preceding section, combinations of resistors can be simplified and analyzed using the expression $\Delta V = IR$ and the rules for series and parallel combinations of resistors. Very often, however, it is not possible to reduce a circuit to a single loop using these rules. The procedure for analyzing more complex circuits is made possible by using the following two principles, called **Kirchhoff's rules**.

1. Junction rule. At any junction, the sum of the currents must equal zero:

$$\sum_{\text{junction}} I = 0 \quad (28.9)$$

2. Loop rule. The sum of the potential differences across all elements around any closed circuit loop must be zero:

$$\sum_{\text{closed loop}} \Delta V = 0 \quad (28.10)$$

Kirchhoff's first rule is a statement of conservation of electric charge. All charges that enter a given point in a circuit must leave that point because charge cannot build up or disappear at a point. Currents directed into the junction are entered into the sum in the junction rule as $+I$, whereas currents directed out of a junction are entered as $-I$. Applying this rule to the junction in Figure 28.12a gives

$$I_1 - I_2 - I_3 = 0$$

Figure 28.12b represents a mechanical analog of this situation, in which water flows through a branched pipe having no leaks. Because water does not build up anywhere in the pipe, the flow rate into the pipe on the left equals the total flow rate out of the two branches on the right.

Kirchhoff's second rule follows from the law of conservation of energy for an isolated system. Let's imagine moving a charge around a closed loop of a circuit. When the charge returns to the starting point, the charge-circuit system must have the same total energy as it had before the charge was moved. The sum of the increases in energy as the charge passes through some circuit elements must equal the sum of the decreases in energy as it passes through other elements. The potential energy of the system decreases whenever the charge moves through a potential drop $-IR$ across a resistor or whenever it moves in the reverse direction through a

The amount of charge flowing out of the branches on the right must equal the amount flowing into the single branch on the left.

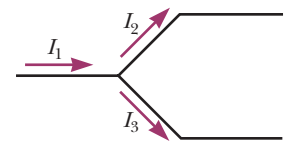

a

The amount of water flowing out of the branches on the right must equal the amount flowing into the single branch on the left.

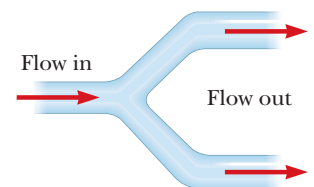

b

Figure 28.12 (a) Kirchhoff's junction rule. (b) A mechanical analog of the junction rule.

In each diagram, $\Delta V = V_b - V_a$ and the circuit element is traversed from a to b , left to right.

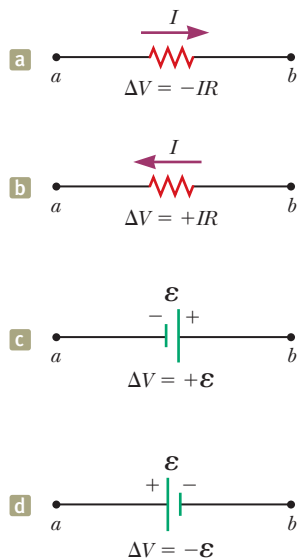

Figure 28.13 Rules for determining the signs of the potential differences across a resistor and a battery. (The battery is assumed to have no internal resistance.)

source of emf. The potential energy increases whenever the charge passes through a battery from the negative terminal to the positive terminal.

When applying Kirchhoff's second rule, imagine *traveling* around the loop and consider changes in *electric potential* rather than the changes in *potential energy* described in the preceding paragraph. Imagine traveling through the circuit elements in Figure 28.13 toward the right. The following sign conventions apply when using the second rule:

- Charges move from the high-potential end of a resistor toward the low-potential end, so if a resistor is traversed in the direction of the current, the potential difference ΔV across the resistor is $-IR$ (Fig. 28.13a).
- If a resistor is traversed in the direction *opposite* the current, the potential difference ΔV across the resistor is $+IR$ (Fig. 28.13b).
- If a source of emf (assumed to have zero internal resistance) is traversed in the direction of the emf (from negative to positive), the potential difference ΔV is $+\epsilon$ (Fig. 28.13c).
- If a source of emf (assumed to have zero internal resistance) is traversed in the direction opposite the emf (from positive to negative), the potential difference ΔV is $-\epsilon$ (Fig. 28.13d).

There are limits on the number of times you can usefully apply Kirchhoff's rules in analyzing a circuit. You can use the junction rule as often as you need as long as you include in it a current that has not been used in a preceding junction-rule equation. In general, the number of times you can use the junction rule is one fewer than the number of junction points in the circuit. You can apply the loop rule as often as needed as long as a new circuit element (resistor or battery) or a new current appears in each new equation. In general, to solve a particular circuit problem, the number of independent equations you need to obtain from the two rules equals the number of unknown currents.

Complex networks containing many loops and junctions generate a great number of independent linear equations and a correspondingly great number of unknowns. Such situations can be handled formally through the use of matrix algebra. Computer software can also be used to solve for the unknowns.

The following examples illustrate how to use Kirchhoff's rules. In all cases, it is assumed the circuits have reached steady-state conditions; in other words, the currents in the various branches are constant. Any capacitor acts as an open branch in a circuit; that is, the current in the branch containing the capacitor is zero under steady-state conditions.

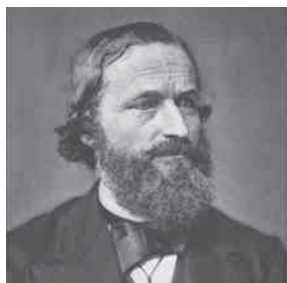

Prints & Photographs Division, Library of Congress, LC-USZ62-133715

Gustav Kirchhoff

German Physicist (1824–1887)

Kirchhoff, a professor at Heidelberg, and Robert Bunsen invented the spectroscope and founded the science of spectroscopy, which we shall study in Chapter 42. They discovered the elements cesium and rubidium and invented astronomical spectroscopy.

Problem-Solving Strategy Kirchhoff's Rules

The following procedure is recommended for solving problems that involve circuits that cannot be reduced by the rules for combining resistors in series or parallel.

- 1. Conceptualize.** Study the circuit diagram and make sure you recognize all elements in the circuit. Identify the polarity of each battery and try to imagine the directions in which the current would exist in the batteries.
- 2. Categorize.** Determine whether the circuit can be reduced by means of combining series and parallel resistors. If so, use the techniques of Section 28.2. If not, apply Kirchhoff's rules according to the *Analyze* step below.
- 3. Analyze.** Assign labels to all known quantities and symbols to all unknown quantities. You must assign *directions* to the currents in each part of the circuit. Although the assignment of current directions is arbitrary, you must adhere *rigorously* to the directions you assign when you apply Kirchhoff's rules.

Apply the junction rule (Kirchhoff's first rule) to all junctions in the circuit except one. Now apply the loop rule (Kirchhoff's second rule) to as many loops in

► **Problem-Solving Strategy** *continued*

the circuit as are needed to obtain, in combination with the equations from the junction rule, as many equations as there are unknowns. To apply this rule, you must choose a direction in which to travel around the loop (either clockwise or counterclockwise) and correctly identify the change in potential as you cross each element. Be careful with signs!

Solve the equations simultaneously for the unknown quantities.

4. Finalize. Check your numerical answers for consistency. Do not be alarmed if any of the resulting currents have a negative value. That only means you have guessed the direction of that current incorrectly, but *its magnitude will be correct*.

Example 28.6 **A Single-Loop Circuit**

A single-loop circuit contains two resistors and two batteries as shown in Figure 28.14. (Neglect the internal resistances of the batteries.) Find the current in the circuit.

SOLUTION

Conceptualize Figure 28.14 shows the polarities of the batteries and a guess at the direction of the current. The 12-V battery is the stronger of the two, so the current should be counterclockwise. Therefore, we expect our guess for the direction of the current to be wrong, but we will continue and see how this incorrect guess is represented by our final answer.

Categorize We do not need Kirchhoff's rules to analyze this simple circuit, but let's use them anyway simply to see how they are applied. There are no junctions in this single-loop circuit; therefore, the current is the same in all elements.

Analyze Let's assume the current is clockwise as shown in Figure 28.14. Traversing the circuit in the clockwise direction, starting at a , we see that $a \rightarrow b$ represents a potential difference of $+\mathcal{E}_1$, $b \rightarrow c$ represents a potential difference of $-IR_1$, $c \rightarrow d$ represents a potential difference of $-\mathcal{E}_2$, and $d \rightarrow a$ represents a potential difference of $-IR_2$.

Apply Kirchhoff's loop rule to the single loop in the circuit:

$$\sum \Delta V = 0 \rightarrow \mathcal{E}_1 - IR_1 - \mathcal{E}_2 - IR_2 = 0$$

Solve for I and use the values given in Figure 28.14:

$$(1) \quad I = \frac{\mathcal{E}_1 - \mathcal{E}_2}{R_1 + R_2} = \frac{6.0 \text{ V} - 12 \text{ V}}{8.0 \Omega + 10 \Omega} = -0.33 \text{ A}$$

Finalize The negative sign for I indicates that the direction of the current is opposite the assumed direction. The emfs in the numerator subtract because the batteries in Figure 28.14 have opposite polarities. The resistances in the denominator add because the two resistors are in series.

WHAT IF? What if the polarity of the 12.0-V battery were reversed? How would that affect the circuit?

Answer Although we could repeat the Kirchhoff's rules calculation, let's instead examine Equation (1) and modify it accordingly. Because the polarities of the two batteries are now in the same direction, the signs of \mathcal{E}_1 and \mathcal{E}_2 are the same and Equation (1) becomes

$$I = \frac{\mathcal{E}_1 + \mathcal{E}_2}{R_1 + R_2} = \frac{6.0 \text{ V} + 12 \text{ V}}{8.0 \Omega + 10 \Omega} = 1.0 \text{ A}$$

Example 28.7 **A Multiloop Circuit**

Find the currents I_1 , I_2 , and I_3 in the circuit shown in Figure 28.15 on page 846.

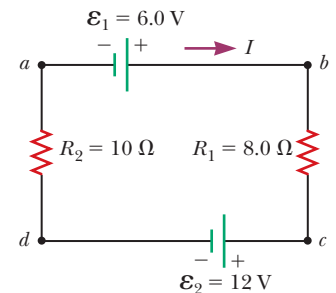

Figure 28.14 (Example 28.6) A series circuit containing two batteries and two resistors, where the polarities of the batteries are in opposition.

continued

28.7 continued

SOLUTION

Conceptualize Imagine physically rearranging the circuit while keeping it electrically the same. Can you rearrange it so that it consists of simple series or parallel combinations of resistors? You should find that you cannot. (If the 10.0-V battery were removed and replaced by a wire from b to the 6.0- Ω resistor, the circuit would consist of only series and parallel combinations.)

Categorize We cannot simplify the circuit by the rules associated with combining resistances in series and in parallel. Therefore, this problem is one in which we must use Kirchhoff's rules.

Analyze We arbitrarily choose the directions of the currents as labeled in Figure 28.15.

Apply Kirchhoff's junction rule to junction c :

$$(1) \quad I_1 + I_2 - I_3 = 0$$

We now have one equation with three unknowns: I_1 , I_2 , and I_3 . There are three loops in the circuit: $abcd$, $befcb$, and $aefta$. We need only two loop equations to determine the unknown currents. (The third equation would give no new information.) Let's choose to traverse these loops in the clockwise direction. Apply Kirchhoff's loop rule to loops $abcd$ and $befcb$:

$$abcd: (2) \quad 10.0 \text{ V} - (6.0 \Omega)I_1 - (2.0 \Omega)I_3 = 0$$

$$befcb: -(4.0 \Omega)I_2 - 14.0 \text{ V} + (6.0 \Omega)I_1 - 10.0 \text{ V} = 0$$

$$(3) \quad -24.0 \text{ V} + (6.0 \Omega)I_1 - (4.0 \Omega)I_2 = 0$$

Solve Equation (1) for I_3 and substitute into Equation (2):

$$10.0 \text{ V} - (6.0 \Omega)I_1 - (2.0 \Omega)(I_1 + I_2) = 0$$

$$(4) \quad 10.0 \text{ V} - (8.0 \Omega)I_1 - (2.0 \Omega)I_2 = 0$$

Multiply each term in Equation (3) by 4 and each term in Equation (4) by 3:

$$(5) \quad -96.0 \text{ V} + (24.0 \Omega)I_1 - (16.0 \Omega)I_2 = 0$$

$$(6) \quad 30.0 \text{ V} - (24.0 \Omega)I_1 - (6.0 \Omega)I_2 = 0$$

Add Equation (6) to Equation (5) to eliminate I_1 and find I_2 :

$$-66.0 \text{ V} - (22.0 \Omega)I_2 = 0$$

$$I_2 = -3.0 \text{ A}$$

Use this value of I_2 in Equation (3) to find I_1 :

$$-24.0 \text{ V} + (6.0 \Omega)I_1 - (4.0 \Omega)(-3.0 \text{ A}) = 0$$

$$-24.0 \text{ V} + (6.0 \Omega)I_1 + 12.0 \text{ V} = 0$$

$$I_1 = 2.0 \text{ A}$$

Use Equation (1) to find I_3 :

$$I_3 = I_1 + I_2 = 2.0 \text{ A} - 3.0 \text{ A} = -1.0 \text{ A}$$

Finalize Because our values for I_2 and I_3 are negative, the directions of these currents are opposite those indicated in Figure 28.15. The numerical values for the currents are correct. Despite the incorrect direction, we *must* continue to use these negative values in subsequent calculations because our equations were established with our original choice of direction. What would have happened had we left the current directions as labeled in Figure 28.15 but traversed the loops in the opposite direction?

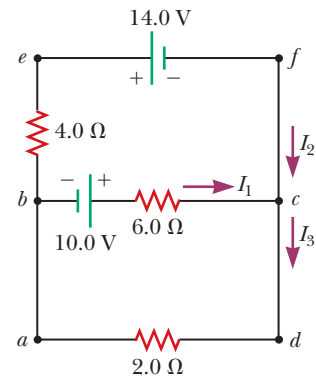

Figure 28.15 (Example 28.7) A circuit containing different branches.

28.4 RC Circuits

So far, we have analyzed direct-current circuits in which the current is constant. In DC circuits containing capacitors, the current is always in the same direction but may vary in magnitude at different times. A circuit containing a series combination of a resistor and a capacitor is called an **RC circuit**.

Charging a Capacitor

Figure 28.16 shows a simple series RC circuit. Let's assume the capacitor in this circuit is initially uncharged. There is no current while the switch is open (Fig. 28.16a). If the switch is thrown to position a at $t = 0$ (Fig. 28.16b), however, charge begins to flow, setting up a current in the circuit, and the capacitor begins to charge.³ Notice that during charging, charges do not jump across the capacitor plates because the gap between the plates represents an open circuit. Instead, charge is transferred between each plate and its connecting wires due to the electric field established in the wires by the battery until the capacitor is fully charged. As the plates are being charged, the potential difference across the capacitor increases. The value of the maximum charge on the plates depends on the voltage of the battery. Once the maximum charge is reached, the current in the circuit is zero because the potential difference across the capacitor matches that supplied by the battery.

To analyze this circuit quantitatively, let's apply Kirchoff's loop rule to the circuit after the switch is thrown to position a . Traversing the loop in Figure 28.16b clockwise gives

$$\mathcal{E} - \frac{q}{C} - iR = 0 \quad (28.11)$$

where q/C is the potential difference across the capacitor and iR is the potential difference across the resistor. We have used the sign conventions discussed earlier for the signs on \mathcal{E} and iR . The capacitor is traversed in the direction from the positive plate to the negative plate, which represents a decrease in potential. Therefore, we use a negative sign for this potential difference in Equation 28.11. Note that lowercase q and i are *instantaneous* values that depend on time (as opposed to steady-state values) as the capacitor is being charged.

We can use Equation 28.11 to find the initial current I_i in the circuit and the maximum charge Q_{\max} on the capacitor. At the instant the switch is thrown to position a ($t = 0$), the charge on the capacitor is zero. Equation 28.11 shows that the initial current I_i in the circuit is a maximum and is given by

$$I_i = \frac{\mathcal{E}}{R} \quad (\text{current at } t = 0) \quad (28.12)$$

At this time, the potential difference from the battery terminals appears entirely across the resistor. Later, when the capacitor is charged to its maximum value Q_{\max} , charges cease to flow, the current in the circuit is zero, and the potential difference from the battery terminals appears entirely across the capacitor. Substituting $i = 0$ into Equation 28.11 gives the maximum charge on the capacitor:

$$Q_{\max} = C\mathcal{E} \quad (\text{maximum charge}) \quad (28.13)$$

To determine analytical expressions for the time dependence of the charge and current, we must solve Equation 28.11, a single equation containing two variables q and i . The current in all parts of the series circuit must be the same. Therefore, the current in the resistance R must be the same as the current between each capacitor plate and the wire connected to it. This current is equal to the time rate of change of the charge on the capacitor plates. Therefore, we substitute $i = dq/dt$ into Equation 28.11 and rearrange the equation:

$$\frac{dq}{dt} = \frac{\mathcal{E}}{R} - \frac{q}{RC}$$

To find an expression for q , we solve this separable differential equation as follows. First combine the terms on the right-hand side:

$$\frac{dq}{dt} = \frac{C\mathcal{E}}{RC} - \frac{q}{RC} = -\frac{q - C\mathcal{E}}{RC}$$

³In previous discussions of capacitors, we assumed a steady-state situation, in which no current was present in any branch of the circuit containing a capacitor. Now we are considering the case *before* the steady-state condition is realized; in this situation, charges are moving and a current exists in the wires connected to the capacitor.

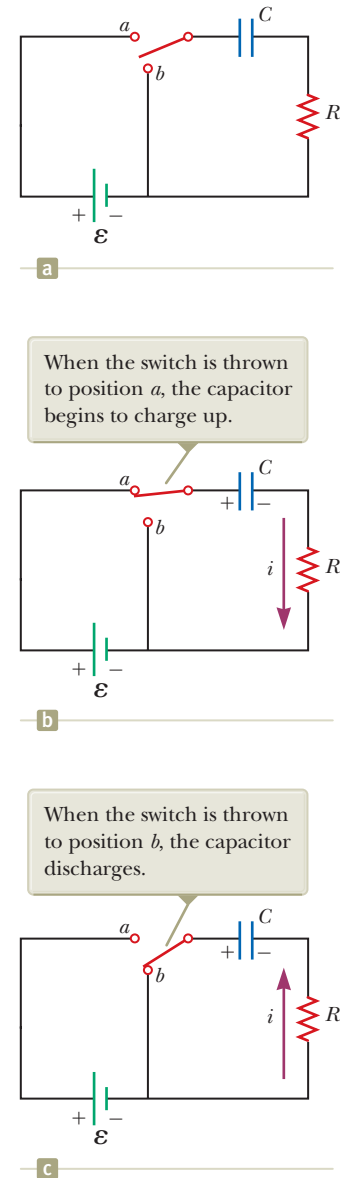

Figure 28.16 A capacitor in series with a resistor, switch, and battery.

Multiply this equation by dt and divide by $q - C\mathcal{E}$:

$$\frac{dq}{q - C\mathcal{E}} = -\frac{1}{RC} dt$$

Integrate this expression, using $q = 0$ at $t = 0$:

$$\int_0^q \frac{dq}{q - C\mathcal{E}} = -\frac{1}{RC} \int_0^t dt$$

$$\ln\left(\frac{q - C\mathcal{E}}{-C\mathcal{E}}\right) = -\frac{t}{RC}$$

From the definition of the natural logarithm, we can write this expression as

$$q(t) = C\mathcal{E}(1 - e^{-t/RC}) = Q_{\max}(1 - e^{-t/RC}) \quad (28.14)$$

where e is the base of the natural logarithm and we have made the substitution from Equation 28.13.

We can find an expression for the charging current by differentiating Equation 28.14 with respect to time. Using $i = dq/dt$, we find that

$$i(t) = \frac{\mathcal{E}}{R} e^{-t/RC} \quad (28.15)$$

Plots of capacitor charge and circuit current versus time are shown in Figure 28.17. Notice that the charge is zero at $t = 0$ and approaches the maximum value $C\mathcal{E}$ as $t \rightarrow \infty$. The current has its maximum value $I_i = \mathcal{E}/R$ at $t = 0$ and decays exponentially to zero as $t \rightarrow \infty$. The quantity RC , which appears in the exponents of Equations 28.14 and 28.15, is called the **time constant** τ of the circuit:

$$\tau = RC \quad (28.16)$$

The time constant represents the time interval during which the current decreases to $1/e$ of its initial value; that is, after a time interval τ , the current decreases to $i = e^{-1}I_i = 0.368I_i$. After a time interval 2τ , the current decreases to $i = e^{-2}I_i = 0.135I_i$, and so forth. Likewise, in a time interval τ , the charge increases from zero to $C\mathcal{E}[1 - e^{-1}] = 0.632C\mathcal{E}$.

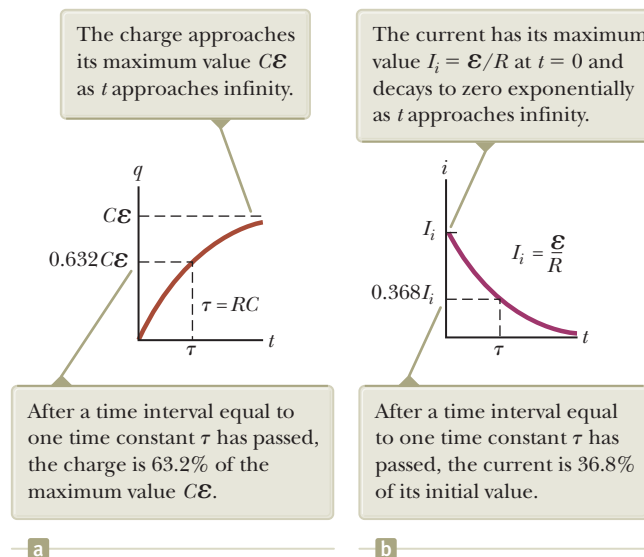

Figure 28.17 (a) Plot of capacitor charge versus time for the circuit shown in Figure 28.16b. (b) Plot of current versus time for the circuit shown in Figure 28.16b.

Charge as a function of time
for a capacitor being
charged

Current as a function of time
for a capacitor being
charged

The following dimensional analysis shows that τ has units of time:

$$[\tau] = [RC] = \left[\left(\frac{\Delta V}{I} \right) \left(\frac{Q}{\Delta V} \right) \right] = \left[\frac{Q}{Q/\Delta t} \right] = [\Delta t] = \text{T}$$

Because $\tau = RC$ has units of time, the combination t/RC is dimensionless, as it must be to be an exponent of e in Equations 28.14 and 28.15.

The energy supplied by the battery during the time interval required to fully charge the capacitor is $Q_{\max}\mathcal{E} = C\mathcal{E}^2$. After the capacitor is fully charged, the energy stored in the capacitor is $\frac{1}{2}Q_{\max}\mathcal{E} = \frac{1}{2}C\mathcal{E}^2$, which is only half the energy output of the battery. It is left as a problem (Problem 68) to show that the remaining half of the energy supplied by the battery appears as internal energy in the resistor.

Discharging a Capacitor

Imagine that the capacitor in Figure 28.16b is completely charged. An initial potential difference Q_i/C exists across the capacitor, and there is zero potential difference across the resistor because $i = 0$. If the switch is now thrown to position b at $t = 0$ (Fig. 28.16c), the capacitor begins to discharge through the resistor. At some time t during the discharge, the current in the circuit is i and the charge on the capacitor is q . The circuit in Figure 28.16c is the same as the circuit in Figure 28.16b except for the absence of the battery. Therefore, we eliminate the emf \mathcal{E} from Equation 28.11 to obtain the appropriate loop equation for the circuit in Figure 28.16c:

$$-\frac{q}{C} - iR = 0 \quad (28.17)$$

When we substitute $i = dq/dt$ into this expression, it becomes

$$\begin{aligned} -R \frac{dq}{dt} &= \frac{q}{C} \\ \frac{dq}{q} &= -\frac{1}{RC} dt \end{aligned}$$

Integrating this expression using $q = Q_i$ at $t = 0$ gives

$$\begin{aligned} \int_{Q_i}^q \frac{dq}{q} &= -\frac{1}{RC} \int_0^t dt \\ \ln \left(\frac{q}{Q_i} \right) &= -\frac{t}{RC} \end{aligned}$$

$$q(t) = Q_i e^{-t/RC} \quad (28.18)$$

Differentiating Equation 28.18 with respect to time gives the instantaneous current as a function of time:

$$i(t) = -\frac{Q_i}{RC} e^{-t/RC} \quad (28.19)$$

where $Q_i/RC = I_i$ is the initial current. The negative sign indicates that as the capacitor discharges, the current direction is opposite its direction when the capacitor was being charged. (Compare the current directions in Figs. 28.16b and 28.16c.) Both the charge on the capacitor and the current decay exponentially at a rate characterized by the time constant $\tau = RC$.

- Quick Quiz 28.5** Consider the circuit in Figure 28.18 and assume the battery has no internal resistance. (i) Just after the switch is closed, what is the current in the battery? (a) 0 (b) $\mathcal{E}/2R$ (c) $2\mathcal{E}/R$ (d) \mathcal{E}/R (e) impossible to determine (ii) After a very long time, what is the current in the battery? Choose from the same choices.

◀ Charge as a function of time for a discharging capacitor

◀ Current as a function of time for a discharging capacitor

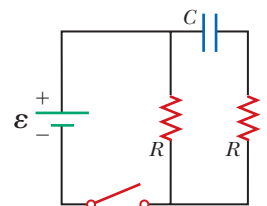

Figure 28.18 (Quick Quiz 28.5) How does the current vary after the switch is closed?

Conceptual Example 28.8 Intermittent Windshield Wipers

Many automobiles are equipped with windshield wipers that can operate intermittently during a light rainfall. How does the operation of such wipers depend on the charging and discharging of a capacitor?

SOLUTION

The wipers are part of an RC circuit whose time constant can be varied by selecting different values of R through a multiposition switch. As the voltage across the capacitor increases, the capacitor reaches a point at which it discharges and triggers the wipers. The circuit then begins another charging cycle. The time interval between the individual sweeps of the wipers is determined by the value of the time constant.

Example 28.9 Charging a Capacitor in an RC Circuit

An uncharged capacitor and a resistor are connected in series to a battery as shown in Figure 28.16, where $\mathcal{E} = 12.0$ V, $C = 5.00$ μF , and $R = 8.00 \times 10^5$ Ω . The switch is thrown to position a . Find the time constant of the circuit, the maximum charge on the capacitor, the maximum current in the circuit, and the charge and current as functions of time.

SOLUTION

Conceptualize Study Figure 28.16 and imagine throwing the switch to position a as shown in Figure 28.16b. Upon doing so, the capacitor begins to charge.

Categorize We evaluate our results using equations developed in this section, so we categorize this example as a substitution problem.

Evaluate the time constant of the circuit from Equation 28.16:

$$\tau = RC = (8.00 \times 10^5 \Omega)(5.00 \times 10^{-6} \text{ F}) = 4.00 \text{ s}$$

Evaluate the maximum charge on the capacitor from Equation 28.13:

$$Q_{\text{max}} = C\mathcal{E} = (5.00 \mu\text{F})(12.0 \text{ V}) = 60.0 \mu\text{C}$$

Evaluate the maximum current in the circuit from Equation 28.12:

$$I_i = \frac{\mathcal{E}}{R} = \frac{12.0 \text{ V}}{8.00 \times 10^5 \Omega} = 15.0 \mu\text{A}$$

Use these values in Equations 28.14 and 28.15 to find the charge and current as functions of time:

$$\begin{aligned} (1) \quad q(t) &= 60.0(1 - e^{-t/4.00}) \\ (2) \quad i(t) &= 15.0e^{-t/4.00} \end{aligned}$$

In Equations (1) and (2), q is in microcoulombs, i is in microamperes, and t is in seconds.

Example 28.10 Discharging a Capacitor in an RC Circuit

Consider a capacitor of capacitance C that is being discharged through a resistor of resistance R as shown in Figure 28.16c.

(A) After how many time constants is the charge on the capacitor one-fourth its initial value?

SOLUTION

Conceptualize Study Figure 28.16 and imagine throwing the switch to position b as shown in Figure 28.16c. Upon doing so, the capacitor begins to discharge.

Categorize We categorize the example as one involving a discharging capacitor and use the appropriate equations.

28.10 continued

Analyze Substitute $q(t) = Q_i/4$ into Equation 28.18:

$$\frac{Q_i}{4} = Q_i e^{-t/RC}$$

$$\frac{1}{4} = e^{-t/RC}$$

Take the logarithm of both sides of the equation and solve for t :

$$-\ln 4 = -\frac{t}{RC}$$

$$t = RC \ln 4 = 1.39RC = 1.39\tau$$

(B) The energy stored in the capacitor decreases with time as the capacitor discharges. After how many time constants is this stored energy one-fourth its initial value?

SOLUTION

Use Equations 26.11 and 28.18 to express the energy stored in the capacitor at any time t :

$$(1) \quad U(t) = \frac{q^2}{2C} = \frac{Q_i^2}{2C} e^{-2t/RC}$$

Substitute $U(t) = \frac{1}{4}(Q_i^2/2C)$ into Equation (1):

$$\frac{1}{4} \frac{Q_i^2}{2C} = \frac{Q_i^2}{2C} e^{-2t/RC}$$

$$\frac{1}{4} = e^{-2t/RC}$$

Take the logarithm of both sides of the equation and solve for t :

$$-\ln 4 = -\frac{2t}{RC}$$

$$t = \frac{1}{2}RC \ln 4 = 0.693RC = 0.693\tau$$

Finalize Notice that because the energy depends on the square of the charge, the energy in the capacitor drops more rapidly than the charge on the capacitor.

WHAT IF? What if you want to describe the circuit in terms of the time interval required for the charge to fall to one-half its original value rather than by the time constant τ ? That would give a parameter for the circuit called its *half-life* $t_{1/2}$. How is the half-life related to the time constant?

Answer In one half-life, the charge falls from Q_i to $Q_i/2$. Therefore, from Equation 28.18,

$$\frac{Q_i}{2} = Q_i e^{-t_{1/2}/RC} \rightarrow \frac{1}{2} = e^{-t_{1/2}/RC}$$

which leads to

$$t_{1/2} = 0.693\tau$$

The concept of half-life will be important to us when we study nuclear decay in Chapter 44. The radioactive decay of an unstable sample behaves in a mathematically similar manner to a discharging capacitor in an RC circuit.

Example 28.11 Energy Delivered to a Resistor **AM**

A $5.00\text{-}\mu\text{F}$ capacitor is charged to a potential difference of 800 V and then discharged through a resistor. How much energy is delivered to the resistor in the time interval required to fully discharge the capacitor?

SOLUTION

Conceptualize In Example 28.10, we considered the energy decrease in a discharging capacitor to a value of one-fourth the initial energy. In this example, the capacitor fully discharges.

Categorize We solve this example using two approaches. The first approach is to model the circuit as an *isolated system* for *energy*. Because energy in an isolated system is conserved, the initial electric potential energy U_E stored in the

continued

► 28.11 continued

capacitor is transformed into internal energy $E_{\text{int}} = E_R$ in the resistor. The second approach is to model the resistor as a *nonisolated system for energy*. Energy enters the resistor by electrical transmission from the capacitor, causing an increase in the resistor's internal energy.

Analyze We begin with the isolated system approach.

Write the appropriate reduction of the conservation of energy equation, Equation 8.2:

$$\Delta U + \Delta E_{\text{int}} = 0$$

Substitute the initial and final values of the energies:

$$(0 - U_E) + (E_{\text{int}} - 0) = 0 \rightarrow E_R = U_E$$

Use Equation 26.11 for the electric potential energy in the capacitor:

$$E_R = \frac{1}{2}C\mathcal{E}^2$$

Substitute numerical values:

$$E_R = \frac{1}{2}(5.00 \times 10^{-6} \text{ F})(800 \text{ V})^2 = \mathbf{1.60 \text{ J}}$$

The second approach, which is more difficult but perhaps more instructive, is to note that as the capacitor discharges through the resistor, the rate at which energy is delivered to the resistor by electrical transmission is i^2R , where i is the instantaneous current given by Equation 28.19.

Evaluate the energy delivered to the resistor by integrating the power over all time because it takes an infinite time interval for the capacitor to completely discharge:

$$P = \frac{dE}{dt} \rightarrow E_R = \int_0^{\infty} P dt$$

Substitute for the power delivered to the resistor:

$$E_R = \int_0^{\infty} i^2 R dt$$

Substitute for the current from Equation 28.19:

$$E_R = \int_0^{\infty} \left(-\frac{Q_i}{RC} e^{-t/RC} \right)^2 R dt = \frac{Q_i^2}{RC^2} \int_0^{\infty} e^{-2t/RC} dt = \frac{\mathcal{E}^2}{R} \int_0^{\infty} e^{-2t/RC} dt$$

Substitute the value of the integral, which is $RC/2$ (see Problem 44):

$$E_R = \frac{\mathcal{E}^2}{R} \left(\frac{RC}{2} \right) = \frac{1}{2}C\mathcal{E}^2$$

Finalize This result agrees with that obtained using the isolated system approach, as it must. We can use this second approach to find the total energy delivered to the resistor at *any* time after the switch is closed by simply replacing the upper limit in the integral with that specific value of t .

28.5 Household Wiring and Electrical Safety

Many considerations are important in the design of an electrical system of a home that will provide adequate electrical service for the occupants while maximizing their safety. We discuss some aspects of a home electrical system in this section.

Household Wiring

Household circuits represent a practical application of some of the ideas presented in this chapter. In our world of electrical appliances, it is useful to understand the power requirements and limitations of conventional electrical systems and the safety measures that prevent accidents.

In a conventional installation, the utility company distributes electric power to individual homes by means of a pair of wires, with each home connected in paral-

labeled to these wires. One wire is called the *live wire*⁴ as illustrated in Figure 28.19, and the other is called the *neutral wire*. The neutral wire is grounded; that is, its electric potential is taken to be zero. The potential difference between the live and neutral wires is approximately 120 V. This voltage alternates in time, and the potential of the live wire oscillates relative to ground. Much of what we have learned so far for the constant-emf situation (direct current) can also be applied to the alternating current that power companies supply to businesses and households. (Alternating voltage and current are discussed in Chapter 33.)

To record a household's energy consumption, a meter is connected in series with the live wire entering the house. After the meter, the wire splits so that there are several separate circuits in parallel distributed throughout the house. Each circuit contains a circuit breaker (or, in older installations, a fuse). A circuit breaker is a special switch that opens if the current exceeds the rated value for the circuit breaker. The wire and circuit breaker for each circuit are carefully selected to meet the current requirements for that circuit. If a circuit is to carry currents as large as 30 A, a heavy wire and an appropriate circuit breaker must be selected to handle this current. A circuit used to power only lamps and small appliances often requires only 20 A. Each circuit has its own circuit breaker to provide protection for that part of the entire electrical system of the house.

As an example, consider a circuit in which a toaster oven, a microwave oven, and a coffee maker are connected (corresponding to R_1 , R_2 , and R_3 in Fig. 28.19). We can calculate the current in each appliance by using the expression $P = I \Delta V$. The toaster oven, rated at 1 000 W, draws a current of $1\,000\text{ W}/120\text{ V} = 8.33\text{ A}$. The microwave oven, rated at 1 300 W, draws 10.8 A, and the coffee maker, rated at 800 W, draws 6.67 A. When the three appliances are operated simultaneously, they draw a total current of 25.8 A. Therefore, the circuit must be wired to handle at least this much current. If the rating of the circuit breaker protecting the circuit is too small—say, 20 A—the breaker will be tripped when the third appliance is turned on, preventing all three appliances from operating. To avoid this situation, the toaster oven and coffee maker can be operated on one 20-A circuit and the microwave oven on a separate 20-A circuit.

Many heavy-duty appliances such as electric ranges and clothes dryers require 240 V for their operation. The power company supplies this voltage by providing a third wire that is 120 V below ground potential (Fig. 28.20). The potential difference between this live wire and the other live wire (which is 120 V above ground potential) is 240 V. An appliance that operates from a 240-V line requires half as much current compared with operating it at 120 V; therefore, smaller wires can be used in the higher-voltage circuit without overheating.

Electrical Safety

When the live wire of an electrical outlet is connected directly to ground, the circuit is completed and a *short-circuit condition* exists. A short circuit occurs when almost zero resistance exists between two points at different potentials, and the result is a very large current. When that happens accidentally, a properly operating circuit breaker opens the circuit and no damage is done. A person in contact with ground, however, can be electrocuted by touching the live wire of a frayed cord or other exposed conductor. An exceptionally effective (and dangerous!) ground contact is made when the person either touches a water pipe (normally at ground potential) or stands on the ground with wet feet. The latter situation represents effective ground contact because normal, nondistilled water is a conductor due to the large number of ions associated with impurities. This situation should be avoided at all cost.

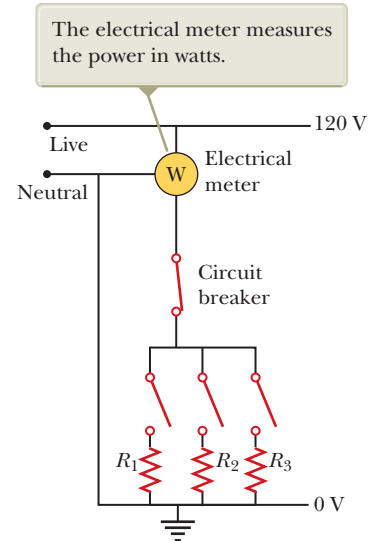
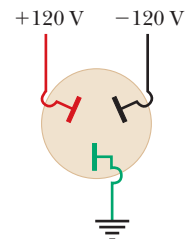

Figure 28.19 Wiring diagram for a household circuit. The resistances represent appliances or other electrical devices that operate with an applied voltage of 120 V.



a



b

Figure 28.20 (a) An outlet for connection to a 240-V supply. (b) The connections for each of the openings in a 240-V outlet.

⁴*Live wire* is a common expression for a conductor whose electric potential is above or below ground potential.

Figure 28.21 (a) A diagram of the circuit for an electric drill with only two connecting wires. The normal current path is from the live wire through the motor connections and back to ground through the neutral wire. (b) This shock can be avoided by connecting the drill case to ground through a third ground wire. The wire colors represent electrical standards in the United States: the “hot” wire is black, the ground wire is green, and the neutral wire is white (shown as gray in the figure).

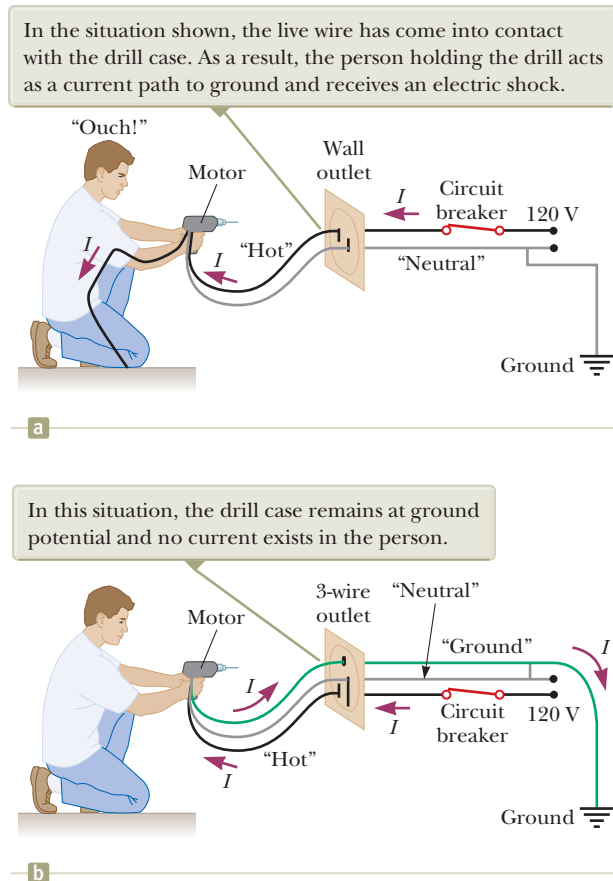

Electric shock can result in fatal burns or can cause the muscles of vital organs such as the heart to malfunction. The degree of damage to the body depends on the magnitude of the current, the length of time it acts, the part of the body touched by the live wire, and the part of the body in which the current exists. Currents of 5 mA or less cause a sensation of shock, but ordinarily do little or no damage. If the current is larger than about 10 mA, the muscles contract and the person may be unable to release the live wire. If the body carries a current of about 100 mA for only a few seconds, the result can be fatal. Such a large current paralyzes the respiratory muscles and prevents breathing. In some cases, currents of approximately 1 A can produce serious (and sometimes fatal) burns. In practice, no contact with live wires is regarded as safe whenever the voltage is greater than 24 V.

Many 120-V outlets are designed to accept a three-pronged power cord. (This feature is required in all new electrical installations.) One of these prongs is the live wire at a nominal potential of 120 V. The second is the neutral wire, nominally at 0 V, which carries current to ground. Figure 28.21a shows a connection to an electric drill with only these two wires. If the live wire accidentally makes contact with the casing of the electric drill (which can occur if the wire insulation wears off), current can be carried to ground by way of the person, resulting in an electric shock. The third wire in a three-pronged power cord, the round prong, is a safety ground wire that normally carries no current. It is both grounded and connected directly to the casing of the appliance. If the live wire is accidentally shorted to the casing in this situation, most of the current takes the low-resistance path through the appliance to ground as shown in Figure 28.21b.

Special power outlets called *ground-fault circuit interrupters*, or GFCIs, are used in kitchens, bathrooms, basements, exterior outlets, and other hazardous areas of homes. These devices are designed to protect persons from electric shock by sensing small currents (< 5 mA) leaking to ground. (The principle of their operation

is described in Chapter 31.) When an excessive leakage current is detected, the current is shut off in less than 1 ms.

Summary

Definition

The **emf** of a battery is equal to the voltage across its terminals when the current is zero. That is, the emf is equivalent to the **open-circuit voltage** of the battery.

Concepts and Principles

The **equivalent resistance** of a set of resistors connected in a **series combination** is

$$R_{\text{eq}} = R_1 + R_2 + R_3 + \cdots \quad (28.6)$$

The **equivalent resistance** of a set of resistors connected in a **parallel combination** is found from the relationship

$$\frac{1}{R_{\text{eq}}} = \frac{1}{R_1} + \frac{1}{R_2} + \frac{1}{R_3} + \cdots \quad (28.8)$$

Circuits involving more than one loop are conveniently analyzed with the use of **Kirchhoff's rules**:

1. Junction rule. At any junction, the sum of the currents must equal zero:

$$\sum_{\text{junction}} I = 0 \quad (28.9)$$

2. Loop rule. The sum of the potential differences across all elements around any circuit loop must be zero:

$$\sum_{\text{closed loop}} \Delta V = 0 \quad (28.10)$$

When a resistor is traversed in the direction of the current, the potential difference ΔV across the resistor is $-IR$. When a resistor is traversed in the direction opposite the current, $\Delta V = +IR$. When a source of emf is traversed in the direction of the emf (negative terminal to positive terminal), the potential difference is $+\mathcal{E}$. When a source of emf is traversed opposite the emf (positive to negative), the potential difference is $-\mathcal{E}$.

If a capacitor is charged with a battery through a resistor of resistance R , the charge on the capacitor and the current in the circuit vary in time according to the expressions

$$q(t) = Q_{\text{max}}(1 - e^{-t/RC}) \quad (28.14)$$

$$i(t) = \frac{\mathcal{E}}{R} e^{-t/RC} \quad (28.15)$$

where $Q_{\text{max}} = C\mathcal{E}$ is the maximum charge on the capacitor. The product RC is called the **time constant** τ of the circuit.

If a charged capacitor of capacitance C is discharged through a resistor of resistance R , the charge and current decrease exponentially in time according to the expressions

$$q(t) = Q_i e^{-t/RC} \quad (28.18)$$

$$i(t) = -\frac{Q_i}{RC} e^{-t/RC} \quad (28.19)$$

where Q_i is the initial charge on the capacitor and Q_i/RC is the initial current in the circuit.

Objective Questions

1. denotes answer available in *Student Solutions Manual/Study Guide*

- Is a circuit breaker wired (a) in series with the device it is protecting, (b) in parallel, or (c) neither in series or in parallel, or (d) is it impossible to tell?
- A battery has some internal resistance. **(i)** Can the potential difference across the terminals of the battery be equal to its emf? (a) no (b) yes, if the battery

is absorbing energy by electrical transmission (c) yes, if more than one wire is connected to each terminal (d) yes, if the current in the battery is zero (e) yes, with no special condition required. **(ii)** Can the terminal voltage exceed the emf? Choose your answer from the same possibilities as in part (i).

3. The terminals of a battery are connected across two resistors in series. The resistances of the resistors are not the same. Which of the following statements are correct? Choose all that are correct. (a) The resistor with the smaller resistance carries more current than the other resistor. (b) The resistor with the larger resistance carries less current than the other resistor. (c) The current in each resistor is the same. (d) The potential difference across each resistor is the same. (e) The potential difference is greatest across the resistor closest to the positive terminal.
4. When operating on a 120-V circuit, an electric heater receives 1.30×10^3 W of power, a toaster receives 1.00×10^3 W, and an electric oven receives 1.54×10^3 W. If all three appliances are connected in parallel on a 120-V circuit and turned on, what is the total current drawn from an external source? (a) 24.0 A (b) 32.0 A (c) 40.0 A (d) 48.0 A (e) none of those answers
5. If the terminals of a battery with zero internal resistance are connected across two identical resistors in series, the total power delivered by the battery is 8.00 W. If the same battery is connected across the same resistors in parallel, what is the total power delivered by the battery? (a) 16.0 W (b) 32.0 W (c) 2.00 W (d) 4.00 W (e) none of those answers
6. Several resistors are connected in series. Which of the following statements is correct? Choose all that are correct. (a) The equivalent resistance is greater than any of the resistances in the group. (b) The equivalent resistance is less than any of the resistances in the group. (c) The equivalent resistance depends on the voltage applied across the group. (d) The equivalent resistance is equal to the sum of the resistances in the group. (e) None of those statements is correct.
7. What is the time constant of the circuit shown in Figure OQ28.7? Each of the five resistors has resistance R , and each of the five capacitors has capacitance C . The internal resistance of the battery is negligible. (a) RC (b) $5RC$ (c) $10RC$ (d) $25RC$ (e) none of those answers

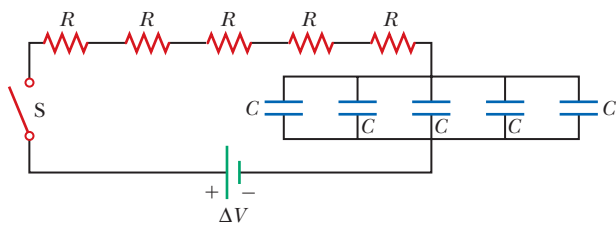

Figure OQ28.7

8. When resistors with different resistances are connected in series, which of the following must be the same for each resistor? Choose all correct answers. (a) potential difference (b) current (c) power delivered (d) charge entering each resistor in a given time interval (e) none of those answers
9. When resistors with different resistances are connected in parallel, which of the following must be the same for each resistor? Choose all correct answers. (a) potential

difference (b) current (c) power delivered (d) charge entering each resistor in a given time interval (e) none of those answers

10. The terminals of a battery are connected across two resistors in parallel. The resistances of the resistors are not the same. Which of the following statements is correct? Choose all that are correct. (a) The resistor with the larger resistance carries more current than the other resistor. (b) The resistor with the larger resistance carries less current than the other resistor. (c) The potential difference across each resistor is the same. (d) The potential difference across the larger resistor is greater than the potential difference across the smaller resistor. (e) The potential difference is greater across the resistor closer to the battery.
11. Are the two headlights of a car wired (a) in series with each other, (b) in parallel, or (c) neither in series nor in parallel, or (d) is it impossible to tell?
12. In the circuit shown in Figure OQ28.12, each battery is delivering energy to the circuit by electrical transmission. All the resistors have equal resistance. (i) Rank the electric potentials at points a , b , c , d , and e from highest to lowest, noting any cases of equality in the ranking. (ii) Rank the magnitudes of the currents at the same points from greatest to least, noting any cases of equality.

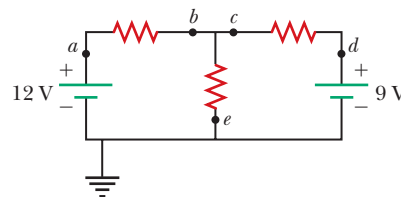

Figure OQ28.12

13. Several resistors are connected in parallel. Which of the following statements are correct? Choose all that are correct. (a) The equivalent resistance is greater than any of the resistances in the group. (b) The equivalent resistance is less than any of the resistances in the group. (c) The equivalent resistance depends on the voltage applied across the group. (d) The equivalent resistance is equal to the sum of the resistances in the group. (e) None of those statements is correct.
14. A circuit consists of three identical lamps connected to a battery as in Figure OQ28.14. The battery has some internal resistance. The switch S , originally open, is closed. (i) What then happens to the brightness of lamp B? (a) It increases. (b) It decreases somewhat. (c) It does not change. (d) It drops to zero. For parts (ii) to (vi), choose from the same possibilities (a) through (d). (ii) What happens to the brightness of lamp C? (iii) What happens to the current in the battery? (iv) What happens to the potential difference across lamp A? (v) What happens to the potential difference

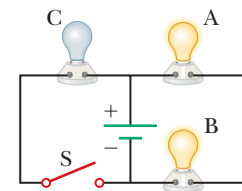

Figure OQ28.14

across lamp C? (vi) What happens to the total power delivered to the lamps by the battery?

15. A series circuit consists of three identical lamps connected to a battery as shown in Figure OQ28.15. The switch S, originally open, is closed. (i) What then happens to the brightness of lamp B? (a) It increases. (b) It decreases somewhat. (c) It does not change. (d) It drops to zero. For parts (ii) to (vi), choose from the same possibilities (a) through (d). (ii) What happens to the brightness of lamp C? (iii) What happens to the current in the battery? (iv) What happens to the potential difference across

lamp A? (v) What happens to the potential difference across lamp C? (vi) What happens to the total power delivered to the lamps by the battery?

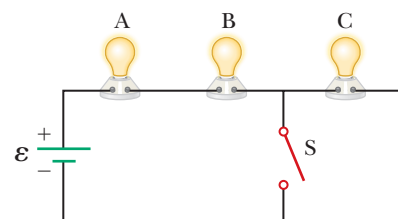

Figure OQ28.15

Conceptual Questions

1. denotes answer available in *Student Solutions Manual/Study Guide*

- Suppose a parachutist lands on a high-voltage wire and grabs the wire as she prepares to be rescued. (a) Will she be electrocuted? (b) If the wire then breaks, should she continue to hold onto the wire as she falls to the ground? Explain.
- A student claims that the second of two lightbulbs in series is less bright than the first because the first lightbulb uses up some of the current. How would you respond to this statement?
- Why is it possible for a bird to sit on a high-voltage wire without being electrocuted?
- Given three lightbulbs and a battery, sketch as many different electric circuits as you can.
- A ski resort consists of a few chairlifts and several interconnected downhill runs on the side of a mountain, with a lodge at the bottom. The chairlifts are analogous to batteries, and the runs are analogous to resistors. Describe how two runs can be in series. Describe how three runs can be in parallel. Sketch a junction between one chairlift and two runs. State Kirchhoff's junction rule for ski resorts. One of the skiers happens to be carrying a skydiver's altimeter. She never takes the same set of chairlifts and runs twice, but keeps passing you at the fixed location where you are working. State Kirchhoff's loop rule for ski resorts.

- Referring to Figure CQ28.6, describe what happens to the lightbulb after the switch is closed. Assume the capacitor has a large capacitance and is initially uncharged. Also assume the light illuminates when connected directly across the battery terminals.

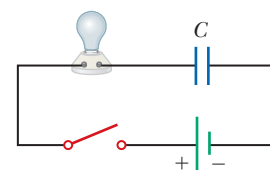

Figure CQ28.6

- So that your grandmother can listen to *A Prairie Home Companion*, you take her bedside radio to the hospital where she is staying. You are required to have a maintenance worker test the radio for electrical safety. Finding that it develops 120 V on one of its knobs, he does not let you take it to your grandmother's room. Your grandmother complains that she has had the radio for many years and nobody has ever gotten a shock from it. You end up having to buy a new plastic radio. (a) Why is your grandmother's old radio dangerous in a hospital room? (b) Will the old radio be safe back in her bedroom?
- (a) What advantage does 120-V operation offer over 240 V? (b) What disadvantages does it have?
- Is the direction of current in a battery always from the negative terminal to the positive terminal? Explain.
- Compare series and parallel resistors to the series and parallel rods in Figure 20.13 on page 610. How are the situations similar?

Problems

ENHANCED WebAssign The problems found in this chapter may be assigned online in Enhanced WebAssign

1. straightforward; 2. intermediate; 3. challenging

1. full solution available in the *Student Solutions Manual/Study Guide*

AMT Analysis Model tutorial available in Enhanced WebAssign

GP Guided Problem

M Master It tutorial available in Enhanced WebAssign

W Watch It video solution available in Enhanced WebAssign

Section 28.1 Electromotive Force

- A battery has an emf of 15.0 V. The terminal voltage of the battery is 11.6 V when it is delivering 20.0 W of

power to an external load resistor R . (a) What is the value of R ? (b) What is the internal resistance of the battery?

2. Two 1.50-V batteries—with their positive terminals in the same direction—are inserted in series into a flashlight. One battery has an internal resistance of $0.255\ \Omega$, and the other has an internal resistance of $0.153\ \Omega$. When the switch is closed, the bulb carries a current of 600 mA. (a) What is the bulb's resistance? (b) What fraction of the chemical energy transformed appears as internal energy in the batteries?

3. An automobile battery has an emf of 12.6 V and an internal resistance of $0.080\ \Omega$. The headlights together have an equivalent resistance of $5.00\ \Omega$ (assumed constant). What is the potential difference across the headlight bulbs (a) when they are the only load on the battery and (b) when the starter motor is operated, with 35.0 A of current in the motor?

4. As in Example 28.2, consider a power supply with fixed emf \mathcal{E} and internal resistance r causing current in a load resistance R . In this problem, R is fixed and r is a variable. The efficiency is defined as the energy delivered to the load divided by the energy delivered by the emf. (a) When the internal resistance is adjusted for maximum power transfer, what is the efficiency? (b) What should be the internal resistance for maximum possible efficiency? (c) When the electric company sells energy to a customer, does it have a goal of high efficiency or of maximum power transfer? Explain. (d) When a student connects a loudspeaker to an amplifier, does she most want high efficiency or high power transfer? Explain.

Section 28.2 Resistors in Series and Parallel

5. Three $100\text{-}\Omega$ resistors are connected as shown in Figure P28.5. The maximum power that can safely be delivered to any one resistor is 25.0 W. (a) What is the maximum potential difference that can be applied to the terminals a and b ? (b) For the voltage determined in part (a), what is the power delivered to each resistor? (c) What is the total power delivered to the combination of resistors?

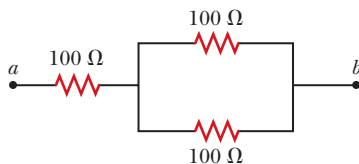

Figure P28.5

6. A lightbulb marked “75 W [at] 120 V” is screwed into a socket at one end of a long extension cord, in which each of the two conductors has resistance $0.800\ \Omega$. The other end of the extension cord is plugged into a 120-V outlet. (a) Explain why the actual power delivered to the lightbulb cannot be 75 W in this situation. (b) Draw a circuit diagram. (c) Find the actual power delivered to the lightbulb in this circuit.

7. What is the equivalent resistance of the combination of identical resistors between points a and b in Figure P28.7?

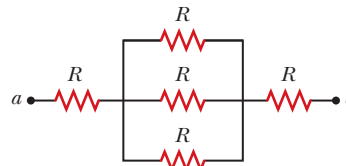

Figure P28.7

8. Consider the two circuits shown in Figure P28.8 in which the batteries are identical. The resistance of each lightbulb is R . Neglect the internal resistances of the batteries. (a) Find expressions for the currents in each lightbulb. (b) How does the brightness of B compare with that of C? Explain. (c) How does the brightness of A compare with that of B and of C? Explain.

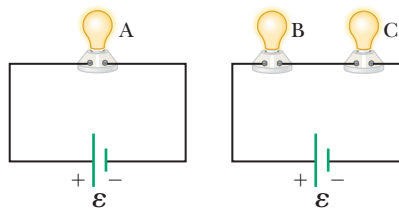

Figure P28.8

9. Consider the circuit shown in Figure P28.9. Find (a) the current in the $20.0\text{-}\Omega$ resistor and (b) the potential difference between points a and b .

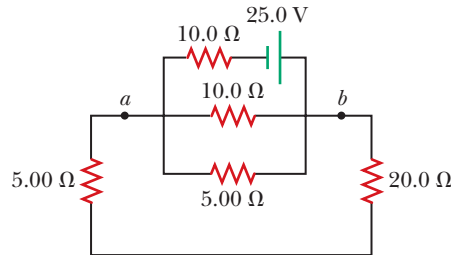

Figure P28.9

10. (a) You need a $45\text{-}\Omega$ resistor, but the stockroom has only $20\text{-}\Omega$ and $50\text{-}\Omega$ resistors. How can the desired resistance be achieved under these circumstances? (b) What can you do if you need a $35\text{-}\Omega$ resistor?

11. A battery with $\mathcal{E} = 6.00\ \text{V}$ and no internal resistance supplies current to the circuit shown in Figure P28.11. When the double-throw switch S is open as shown in the figure, the current in the battery is 1.00 mA. When the switch is closed in position a , the current in the

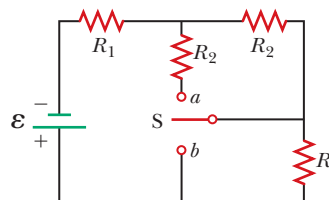

Figure P28.11

Problems 11 and 12.

battery is 1.20 mA. When the switch is closed in position b , the current in the battery is 2.00 mA. Find the resistances (a) R_1 , (b) R_2 , and (c) R_3 .

12. A battery with emf \mathcal{E} and no internal resistance supplies current to the circuit shown in Figure P28.11. When the double-throw switch S is open as shown in the figure, the current in the battery is I_0 . When the switch is closed in position a , the current in the battery is I_a . When the switch is closed in position b , the current in the battery is I_b . Find the resistances (a) R_1 , (b) R_2 , and (c) R_3 .

13. (a) Find the equivalent resistance between points a and b in Figure P28.13. (b) Calculate the current in each resistor if a potential difference of 34.0 V is applied between points a and b .

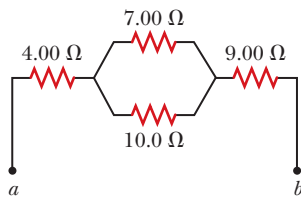

Figure P28.13

14. (a) When the switch S in the circuit of Figure P28.14 is closed, will the equivalent resistance between points a and b increase or decrease? State your reasoning. (b) Assume the equivalent resistance drops by 50.0% when the switch is closed. Determine the value of R .

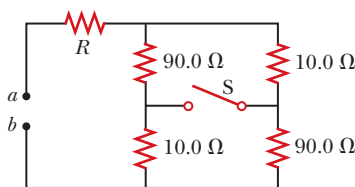

Figure P28.14

15. Two resistors connected in series have an equivalent resistance of 690 Ω . When they are connected in parallel, their equivalent resistance is 150 Ω . Find the resistance of each resistor.
16. Four resistors are connected to a battery as shown in Figure P28.16. (a) Determine the potential difference across each resistor in terms of \mathcal{E} . (b) Determine the current in each resistor in terms of I . (c) **What If?** If R_3 is increased, explain what happens to the current in each of the resistors. (d) In the limit that $R_3 \rightarrow \infty$, what are the new values of the current in each resistor in terms of I , the original current in the battery?

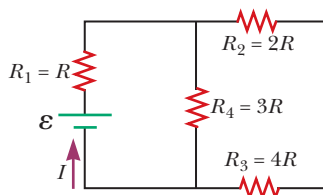

Figure P28.16

17. Consider the combination of resistors shown in Figure P28.17. (a) Find the equivalent resistance between points a and b . (b) If a voltage of 35.0 V is applied between points a and b , find the current in each resistor.

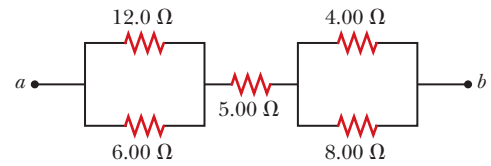

Figure P28.17

18. For the purpose of measuring the electric resistance of shoes through the body of the wearer standing on a metal ground plate, the American National Standards Institute (ANSI) specifies the circuit shown in Figure P28.18. The potential difference ΔV across the 1.00-M Ω resistor is measured with an ideal voltmeter. (a) Show that the resistance of the footwear is

$$R_{\text{shoes}} = \frac{50.0 \text{ V} - \Delta V}{\Delta V}$$

- (b) In a medical test, a current through the human body should not exceed 150 μA . Can the current delivered by the ANSI-specified circuit exceed 150 μA ? To decide, consider a person standing barefoot on the ground plate.

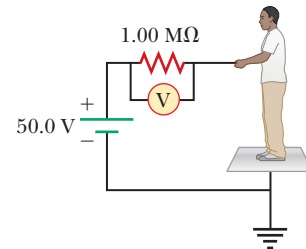

Figure P28.18

19. Calculate the power delivered to each resistor in the circuit shown in Figure P28.19.

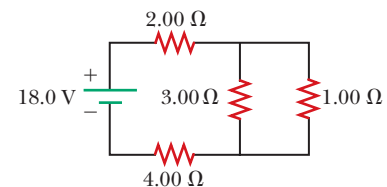

Figure P28.19

20. Why is the following situation impossible? A technician is testing a circuit that contains a resistance R . He realizes that a better design for the circuit would include a resistance $\frac{7}{3}R$ rather than R . He has three additional resistors, each with resistance R . By combining these additional resistors in a certain combination that is then placed in series with the original resistor, he achieves the desired resistance.

21. Consider the circuit shown in Figure P28.21 on page 860. (a) Find the voltage across the 3.00- Ω resistor. (b) Find the current in the 3.00- Ω resistor.

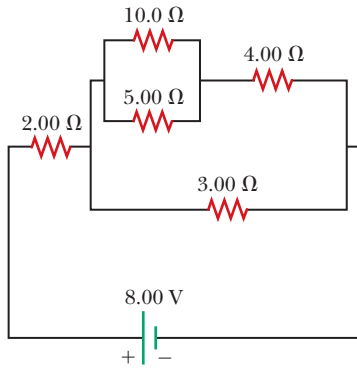

Figure P28.21

Section 28.3 Kirchhoff's Rules

22. In Figure P28.22, show how to add just enough ammeters to measure every different current. Show how to add just enough voltmeters to measure the potential difference across each resistor and across each battery.

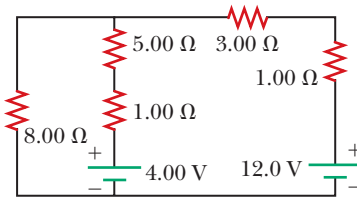

Figure P28.22 Problems 22 and 23.

23. The circuit shown in Figure P28.22 is connected for 2.00 min. (a) Determine the current in each branch of the circuit. (b) Find the energy delivered by each battery. (c) Find the energy delivered to each resistor. (d) Identify the type of energy storage transformation that occurs in the operation of the circuit. (e) Find the total amount of energy transformed into internal energy in the resistors.

24. For the circuit shown in Figure P28.24, calculate (a) the current in the 2.00-Ω resistor and (b) the potential difference between points *a* and *b*.

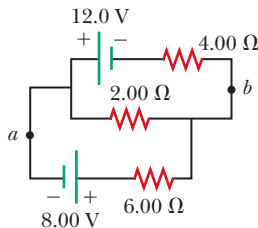

Figure P28.24

25. What are the expected readings of (a) the ideal ammeter and (b) the ideal voltmeter in Figure P28.25?

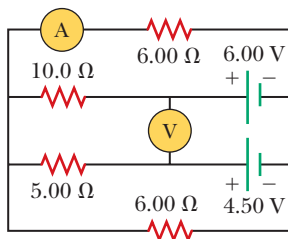

Figure P28.25

26. The following equations describe an electric circuit:

$$\begin{aligned}
 -I_1 (220 \, \Omega) + 5.80 \, \text{V} - I_2 (370 \, \Omega) &= 0 \\
 +I_2 (370 \, \Omega) + I_3 (150 \, \Omega) - 3.10 \, \text{V} &= 0 \\
 I_1 + I_3 - I_2 &= 0
 \end{aligned}$$

(a) Draw a diagram of the circuit. (b) Calculate the unknowns and identify the physical meaning of each unknown.

27. Taking $R = 1.00 \, \text{k}\Omega$ and $\mathcal{E} = 250 \, \text{V}$ in Figure P28.27, determine the direction and magnitude of the current in the horizontal wire between *a* and *e*.

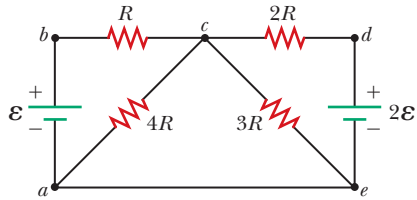

Figure P28.27

28. Jumper cables are connected from a fresh battery in one car to charge a dead battery in another car. Figure P28.28 shows the circuit diagram for this situation. While the cables are connected, the ignition switch of the car with the dead battery is closed and the starter is activated to start the engine. Determine the current in (a) the starter and (b) the dead battery. (c) Is the dead battery being charged while the starter is operating?

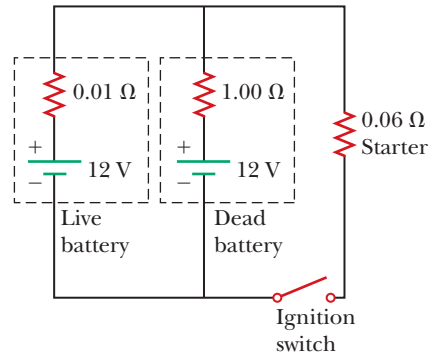

Figure P28.28

29. The ammeter shown in Figure P28.29 reads 2.00 A. Find (a) I_1 , (b) I_2 , and (c) \mathcal{E} .

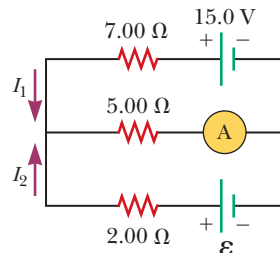

Figure P28.29

30. In the circuit of Figure P28.30, determine (a) the current in each resistor and (b) the potential difference across the 200-Ω resistor.

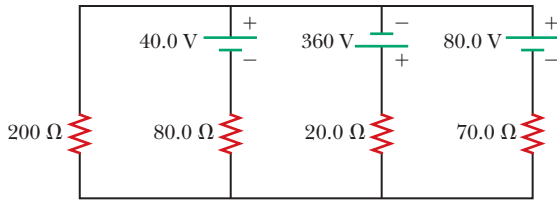

Figure P28.30

31. Using Kirchhoff's rules, (a) find the current in each resistor shown in Figure P28.31 and (b) find the potential difference between points c and f .

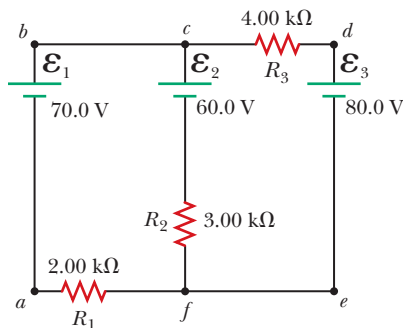

Figure P28.31

32. In the circuit of Figure P28.32, the current $I_1 = 3.00$ A and the values of \mathcal{E} for the ideal battery and R are unknown. What are the currents (a) I_2 and (b) I_3 ? (c) Can you find the values of \mathcal{E} and R ? If so, find their values. If not, explain.

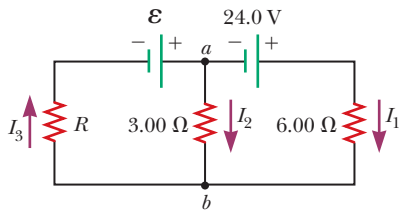

Figure P28.32

33. In Figure P28.33, find (a) the current in each resistor and (b) the power delivered to each resistor.

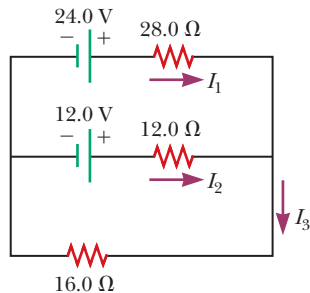

Figure P28.33

34. For the circuit shown in Figure P28.34, we wish to find the currents I_1 , I_2 , and I_3 . Use Kirchhoff's rules to obtain equations for (a) the upper loop, (b) the lower

loop, and (c) the junction on the left side. In each case, suppress units for clarity and simplify, combining the terms. (d) Solve the junction equation for I_3 . (e) Using the equation found in part (d), eliminate I_3 from the equation found in part (b). (f) Solve the equations found in parts (a) and (e) simultaneously for the two unknowns I_1 and I_2 . (g) Substitute the answers found in part (f) into the junction equation found in part (d), solving for I_3 . (h) What is the significance of the negative answer for I_2 ?

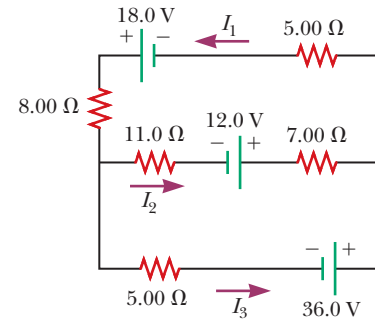

Figure P28.34

35. Find the potential difference across each resistor in Figure P28.35.

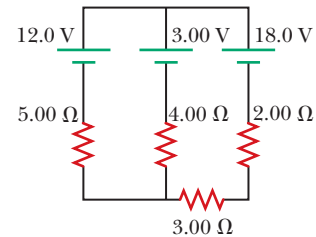

Figure P28.35

36. (a) Can the circuit shown in Figure P28.36 be reduced to a single resistor connected to a battery? Explain. Calculate the currents (b) I_1 , (c) I_2 , and (d) I_3 .

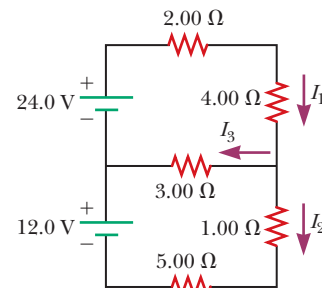

Figure P28.36

Section 28.4 RC Circuits

37. An uncharged capacitor and a resistor are connected in series to a source of emf. If $\mathcal{E} = 9.00$ V, $C = 20.0$ μ F, and $R = 100$ Ω , find (a) the time constant of the circuit, (b) the maximum charge on the capacitor, and (c) the charge on the capacitor at a time equal to one time constant after the battery is connected.

- 38.** Consider a series RC circuit as in Figure P28.38 for which $R = 1.00\text{ M}\Omega$, $C = 5.00\text{ }\mu\text{F}$, and $\mathcal{E} = 30.0\text{ V}$. Find (a) the time constant of the circuit and (b) the maximum charge on the capacitor after the switch is thrown closed. (c) Find the current in the resistor 10.0 s after the switch is closed.

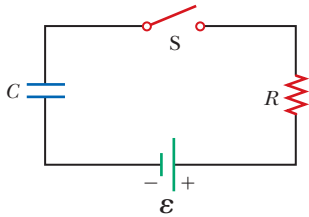

Figure P28.38

Problems 38, 67, and 68.

- 39.** A 2.00-nF capacitor with an initial charge of $5.10\text{ }\mu\text{C}$ is discharged through a $1.30\text{-k}\Omega$ resistor. (a) Calculate the current in the resistor $9.00\text{ }\mu\text{s}$ after the resistor is connected across the terminals of the capacitor. (b) What charge remains on the capacitor after $8.00\text{ }\mu\text{s}$? (c) What is the maximum current in the resistor?

- 40.** A $10.0\text{-}\mu\text{F}$ capacitor is charged by a 10.0-V battery through a resistance R . The capacitor reaches a potential difference of 4.00 V in a time interval of 3.00 s after charging begins. Find R .

- 41.** In the circuit of Figure P28.41, the switch S has been open for a long time. It is then suddenly closed. Take $\mathcal{E} = 10.0\text{ V}$, $R_1 = 50.0\text{ k}\Omega$, $R_2 = 100\text{ k}\Omega$, and $C = 10.0\text{ }\mu\text{F}$. Determine the time constant (a) before the switch is closed and (b) after the switch is closed. (c) Let the switch be closed at $t = 0$. Determine the current in the switch as a function of time.

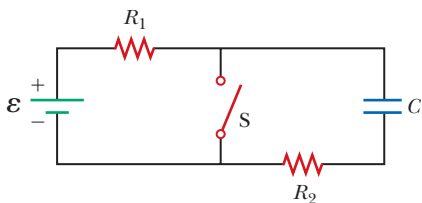

Figure P28.41 Problems 41 and 42.

- 42.** In the circuit of Figure P28.41, the switch S has been open for a long time. It is then suddenly closed. Determine the time constant (a) before the switch is closed and (b) after the switch is closed. (c) Let the switch be closed at $t = 0$. Determine the current in the switch as a function of time.

- 43.** The circuit in Figure P28.43 has been connected for a long time. (a) What is the potential difference across the capacitor? (b) If the battery is disconnected from the circuit, over what time interval does the capacitor discharge to one-tenth its initial voltage?

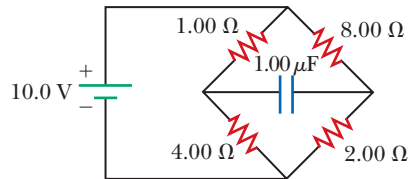

Figure P28.43

- 44.** Show that the integral $\int_0^\infty e^{-2t/RC} dt$ in Example 28.11 has the value $\frac{1}{2}RC$.
- 45.** A charged capacitor is connected to a resistor and switch as in Figure P28.45. The circuit has a time constant of 1.50 s . Soon after the switch is closed, the charge on the capacitor is 75.0% of its initial charge. (a) Find the time interval required for the capacitor to reach this charge. (b) If $R = 250\text{ k}\Omega$, what is the value of C ?

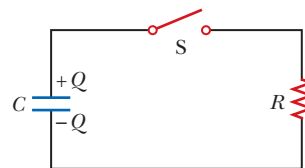

Figure P28.45

Section 28.5 Household Wiring and Electrical Safety

- 46.** An electric heater is rated at $1.50 \times 10^3\text{ W}$, a toaster at 750 W , and an electric grill at $1.00 \times 10^3\text{ W}$. The three appliances are connected to a common 120-V household circuit. (a) How much current does each draw? (b) If the circuit is protected with a 25.0-A circuit breaker, will the circuit breaker be tripped in this situation? Explain your answer.

- 47.** A heating element in a stove is designed to receive $3\text{ }000\text{ W}$ when connected to 240 V . (a) Assuming the resistance is constant, calculate the current in the heating element if it is connected to 120 V . (b) Calculate the power it receives at that voltage.

- 48.** Turn on your desk lamp. Pick up the cord, with your thumb and index finger spanning the width of the cord. (a) Compute an order-of-magnitude estimate for the current in your hand. Assume the conductor inside the lamp cord next to your thumb is at potential $\sim 10^2\text{ V}$ at a typical instant and the conductor next to your index finger is at ground potential (0 V). The resistance of your hand depends strongly on the thickness and the moisture content of the outer layers of your skin. Assume the resistance of your hand between fingertip and thumb tip is $\sim 10^4\text{ }\Omega$. You may model the cord as having rubber insulation. State the other quantities you measure or estimate and their values. Explain your reasoning. (b) Suppose your body is isolated from any other charges or currents. In order-of-magnitude terms, estimate the potential difference between your thumb where it contacts the cord and your finger where it touches the cord.

Additional Problems

49. Assume you have a battery of emf \mathcal{E} and three identical lightbulbs, each having constant resistance R . What is the total power delivered by the battery if the lightbulbs are connected (a) in series and (b) in parallel? (c) For which connection will the lightbulbs shine the brightest?
50. Find the equivalent resistance between points a and b in Figure P28.50.

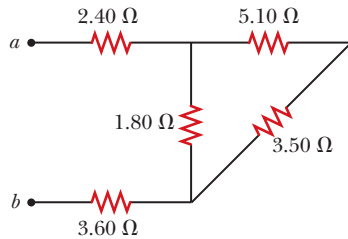

Figure P28.50

51. Four 1.50-V AA batteries in series are used to power a small radio. If the batteries can move a charge of 240 C, how long will they last if the radio has a resistance of 200 Ω ?
52. Four resistors are connected in parallel across a 9.20-V battery. They carry currents of 150 mA, 45.0 mA, 14.0 mA, and 4.00 mA. If the resistor with the largest resistance is replaced with one having twice the resistance, (a) what is the ratio of the new current in the battery to the original current? (b) **What If?** If instead the resistor with the smallest resistance is replaced with one having twice the resistance, what is the ratio of the new total current to the original current? (c) On a February night, energy leaves a house by several energy leaks, including 1.50×10^3 W by conduction through the ceiling, 450 W by infiltration (airflow) around the windows, 140 W by conduction through the basement wall above the foundation sill, and 40.0 W by conduction through the plywood door to the attic. To produce the biggest saving in heating bills, which one of these energy transfers should be reduced first? Explain how you decide. Clifford Swartz suggested the idea for this problem.

53. The circuit in Figure P28.53 has been connected for several seconds. Find the current (a) in the 4.00-V bat-

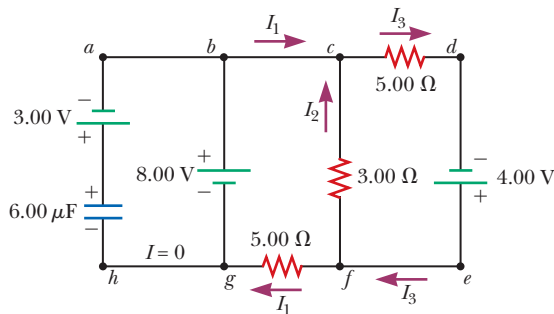

Figure P28.53

tery, (b) in the 3.00- Ω resistor, (c) in the 8.00-V battery, and (d) in the 3.00-V battery. (e) Find the charge on the capacitor.

54. The circuit in Figure P28.54a consists of three resistors and one battery with no internal resistance. (a) Find the current in the 5.00- Ω resistor. (b) Find the power delivered to the 5.00- Ω resistor. (c) In each of the circuits in Figures P28.54b, P28.54c, and P28.54d, an additional 15.0-V battery has been inserted into the circuit. Which diagram or diagrams represent a circuit that requires the use of Kirchhoff's rules to find the currents? Explain why. (d) In which of these three new circuits is the smallest amount of power delivered to the 10.0- Ω resistor? (You need not calculate the power in each circuit if you explain your answer.)

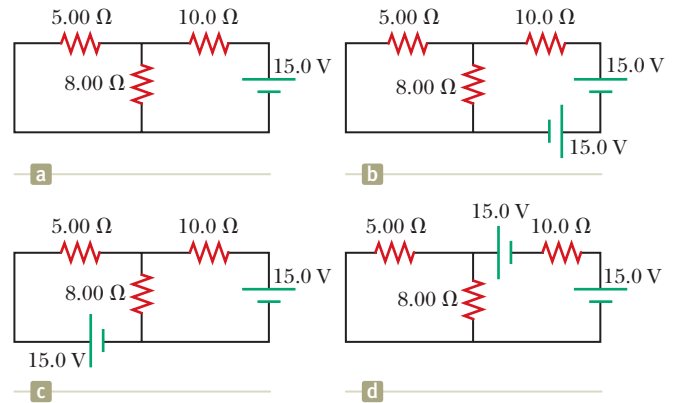

Figure P28.54

55. For the circuit shown in Figure P28.55, the ideal voltmeter reads 6.00 V and the ideal ammeter reads 3.00 mA. Find (a) the value of R , (b) the emf of the battery, and (c) the voltage across the 3.00-k Ω resistor.

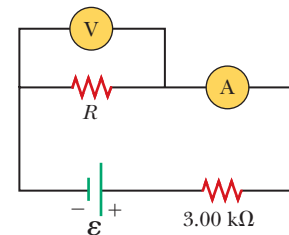

Figure P28.55

56. The resistance between terminals a and b in Figure P28.56 is 75.0 Ω . If the resistors labeled R have the same value, determine R .

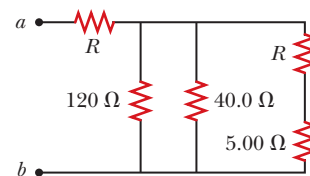

Figure P28.56

57. (a) Calculate the potential difference between points a and b in Figure P28.57 and (b) identify which point is at the higher potential.

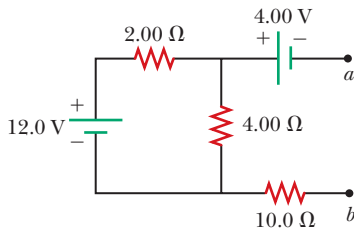

Figure P28.57

58. Why is the following situation impossible? A battery has an emf of $\mathcal{E} = 9.20$ V and an internal resistance of $r = 1.20$ Ω . A resistance R is connected across the battery and extracts from it a power of $P = 21.2$ W.

59. A rechargeable battery has an emf of 13.2 V and an internal resistance of 0.850 Ω . It is charged by a 14.7-V power supply for a time interval of 1.80 h. After charging, the battery returns to its original state as it delivers a constant current to a load resistor over 7.30 h. Find the efficiency of the battery as an energy storage device. (The efficiency here is defined as the energy delivered to the load during discharge divided by the energy delivered by the 14.7-V power supply during the charging process.)

60. Find (a) the equivalent resistance of the circuit in Figure P28.60, (b) the potential difference across each resistor, (c) each current indicated in Figure P28.60, and (d) the power delivered to each resistor.

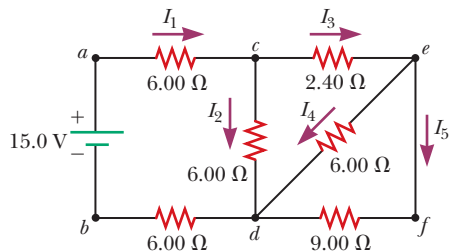

Figure P28.60

61. When two unknown resistors are connected in series with a battery, the battery delivers 225 W and carries a total current of 5.00 A. For the same total current, 50.0 W is delivered when the resistors are connected in parallel. Determine the value of each resistor.

62. When two unknown resistors are connected in series with a battery, the battery delivers total power P_s and carries a total current of I . For the same total current, a total power P_p is delivered when the resistors are connected in parallel. Determine the value of each resistor.

63. The pair of capacitors in Figure P28.63 are fully charged by a 12.0-V battery. The battery is disconnected, and the switch is then closed. After 1.00 ms has elapsed, (a) how much charge remains on the 3.00- μ F

capacitor? (b) How much charge remains on the 2.00- μ F capacitor? (c) What is the current in the resistor at this time?

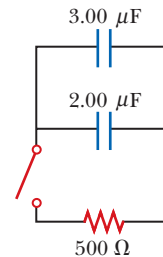

Figure P28.63

64. A power supply has an open-circuit voltage of 40.0 V and an internal resistance of 2.00 Ω . It is used to charge two storage batteries connected in series, each having an emf of 6.00 V and internal resistance of 0.300 Ω . If the charging current is to be 4.00 A, (a) what additional resistance should be added in series? At what rate does the internal energy increase in (b) the supply, (c) in the batteries, and (d) in the added series resistance? (e) At what rate does the chemical energy increase in the batteries?

65. The circuit in Figure P28.65 contains two resistors, $R_1 = 2.00$ k Ω and $R_2 = 3.00$ k Ω , and two capacitors, $C_1 = 2.00$ μ F and $C_2 = 3.00$ μ F, connected to a battery with emf $\mathcal{E} = 120$ V. If there are no charges on the capacitors before switch S is closed, determine the charges on capacitors (a) C_1 and (b) C_2 as functions of time, after the switch is closed.

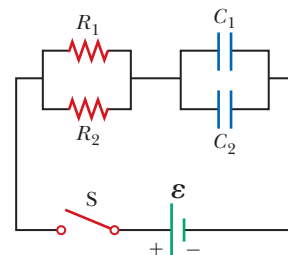

Figure P28.65

66. Two resistors R_1 and R_2 are in parallel with each other. Together they carry total current I . (a) Determine the current in each resistor. (b) Prove that this division of the total current I between the two resistors results in less power delivered to the combination than any other division. It is a general principle that *current in a direct current circuit distributes itself so that the total power delivered to the circuit is a minimum*.

67. The values of the components in a simple series RC circuit containing a switch (Fig. P28.38) are $C = 1.00$ μ F, $R = 2.00 \times 10^6$ Ω , and $\mathcal{E} = 10.0$ V. At the instant 10.0 s after the switch is closed, calculate (a) the charge on the capacitor, (b) the current in the resistor, (c) the rate at which energy is being stored in the capacitor, and (d) the rate at which energy is being delivered by the battery.

68. A battery is used to charge a capacitor through a resistor as shown in Figure P28.38. Show that half the energy supplied by the battery appears as internal energy in the resistor and half is stored in the capacitor.
69. A young man owns a canister vacuum cleaner marked “535 W [at] 120 V” and a Volkswagen Beetle, which he wishes to clean. He parks the car in his apartment parking lot and uses an inexpensive extension cord 15.0 m long to plug in the vacuum cleaner. You may assume the cleaner has constant resistance. (a) If the resistance of each of the two conductors in the extension cord is $0.900\ \Omega$, what is the actual power delivered to the cleaner? (b) If instead the power is to be at least 525 W, what must be the diameter of each of two identical copper conductors in the cord he buys? (c) Repeat part (b) assuming the power is to be at least 532 W.
70. (a) Determine the equilibrium charge on the capacitor in the circuit of Figure P28.70 as a function of R . (b) Evaluate the charge when $R = 10.0\ \Omega$. (c) Can the charge on the capacitor be zero? If so, for what value of R ? (d) What is the maximum possible magnitude of the charge on the capacitor? For what value of R is it achieved? (e) Is it experimentally meaningful to take $R = \infty$? Explain your answer. If so, what charge magnitude does it imply?

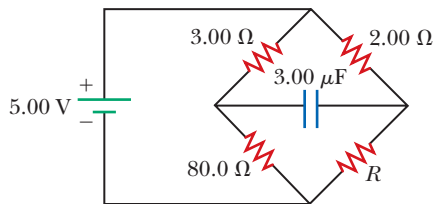

Figure P28.70

71. Switch S shown in Figure P28.71 has been closed for a long time, and the electric circuit carries a constant current. Take $C_1 = 3.00\ \mu\text{F}$, $C_2 = 6.00\ \mu\text{F}$, $R_1 = 4.00\ \text{k}\Omega$, and $R_2 = 7.00\ \text{k}\Omega$. The power delivered to R_2 is 2.40 W. (a) Find the charge on C_1 . (b) Now the switch is opened. After many milliseconds, by how much has the charge on C_2 changed?

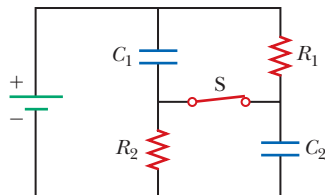

Figure P28.71

72. Three identical 60.0-W, 120-V lightbulbs are connected across a 120-V power source as shown in Figure P28.72. Assuming the resistance of each lightbulb is constant (even though in reality the resistance might increase markedly with current), find (a) the total power supplied by the power source and (b) the potential difference across each lightbulb.

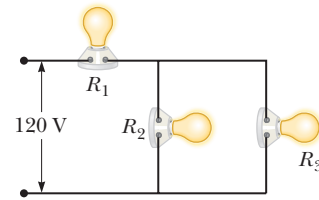

Figure P28.72

73. A regular tetrahedron is a pyramid with a triangular base and triangular sides as shown in Figure P28.73. Imagine the six straight lines in Figure P28.73 are each $10.0\text{-}\Omega$ resistors, with junctions at the four vertices. A 12.0-V battery is connected to any two of the vertices. Find (a) the equivalent resistance of the tetrahedron between these vertices and (b) the current in the battery.

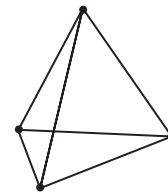

Figure P28.73

74. An ideal voltmeter connected across a certain fresh 9-V battery reads 9.30 V, and an ideal ammeter briefly connected across the same battery reads 3.70 A. We say the battery has an open-circuit voltage of 9.30 V and a short-circuit current of 3.70 A. Model the battery as a source of emf \mathcal{E} in series with an internal resistance r as in Figure 28.1a. Determine both (a) \mathcal{E} and (b) r . An experimenter connects two of these identical batteries together as shown in Figure P28.74. Find (c) the open-circuit voltage and (d) the short-circuit current of the pair of connected batteries. (e) The experimenter connects a $12.0\text{-}\Omega$ resistor between the exposed terminals of the connected batteries. Find the current in the resistor. (f) Find the power delivered to the resistor. (g) The experimenter connects a second identical resistor in parallel with the first. Find the power delivered to each resistor. (h) Because the same pair of batteries is connected across both resistors as was connected across the single resistor, why is the power in part (g) not the same as that in part (f)?

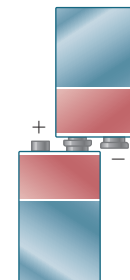

Figure P28.74

75. In Figure P28.75 on page 866, suppose the switch has been closed for a time interval sufficiently long for the capacitor to become fully charged. Find (a) the

steady-state current in each resistor and (b) the charge Q_{\max} on the capacitor. (c) The switch is now opened at $t = 0$. Write an equation for the current in R_2 as a function of time and (d) find the time interval required for the charge on the capacitor to fall to one-fifth its initial value.

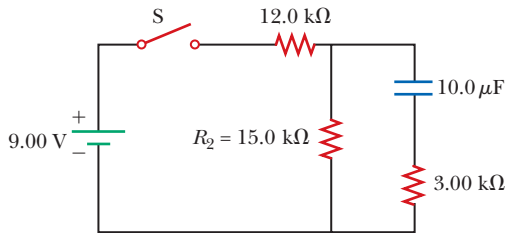

Figure P28.75

76. Figure P28.76 shows a circuit model for the transmission of an electrical signal such as cable TV to a large number of subscribers. Each subscriber connects a load resistance R_L between the transmission line and the ground. The ground is assumed to be at zero potential and able to carry any current between any ground connections with negligible resistance. The resistance of the transmission line between the connection points of different subscribers is modeled as the constant resistance R_T . Show that the equivalent resistance across the signal source is

$$R_{\text{eq}} = \frac{1}{2} [(4R_T R_L + R_T^2)^{1/2} + R_T]$$

Suggestion: Because the number of subscribers is large, the equivalent resistance would not change noticeably if the first subscriber canceled the service. Consequently, the equivalent resistance of the section of the circuit to the right of the first load resistor is nearly equal to R_{eq} .

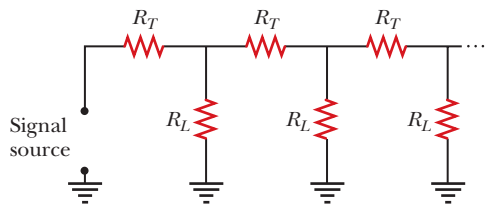

Figure P28.76

77. The student engineer of a campus radio station wishes to verify the effectiveness of the lightning rod on the antenna mast (Fig. P28.77). The unknown resistance R_x is between points C and E . Point E is a true ground, but it is inaccessible for direct measurement because this stratum is several meters below the Earth's surface. Two identical rods are driven into the ground at A and B , introducing an unknown resistance R_y . The procedure is as follows. Measure resistance R_1 between points A and B , then connect A and B with a heavy conducting wire and measure resistance R_2 between points A and C . (a) Derive an equation for R_x in terms of the

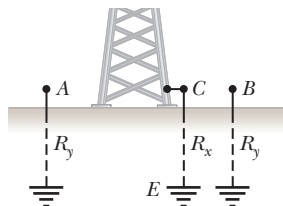

Figure P28.77

observable resistances, R_1 and R_2 . (b) A satisfactory ground resistance would be $R_x < 2.00 \Omega$. Is the grounding of the station adequate if measurements give $R_1 = 13.0 \Omega$ and $R_2 = 6.00 \Omega$? Explain.

78. The circuit shown in Figure P28.78 is set up in the laboratory to measure an unknown capacitance C in series with a resistance $R = 10.0 \text{ M}\Omega$ powered by a battery whose emf is 6.19 V. The data given in the table are the measured voltages across the capacitor as a function of time, where $t = 0$ represents the instant at which the switch is thrown to position b . (a) Construct a graph of $\ln(\mathcal{E}/\Delta v)$ versus t and perform a linear least-squares fit to the data. (b) From the slope of your graph, obtain a value for the time constant of the circuit and a value for the capacitance.

Δv (V)	t (s)	$\ln(\mathcal{E}/\Delta v)$
6.19	0	
5.55	4.87	
4.93	11.1	
4.34	19.4	
3.72	30.8	
3.09	46.6	
2.47	67.3	
1.83	102.2	

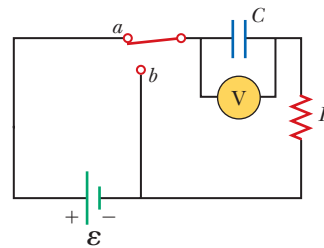

Figure P28.78

79. An electric teakettle has a multiposition switch and two heating coils. When only one coil is switched on, the well-insulated kettle brings a full pot of water to a boil over the time interval Δt . When only the other coil is switched on, it takes a time interval of $2 \Delta t$ to boil the same amount of water. Find the time interval required to boil the same amount of water if both coils are switched on (a) in a parallel connection and (b) in a series connection.

80. A voltage ΔV is applied to a series configuration of n resistors, each of resistance R . The circuit components are reconnected in a parallel configuration, and voltage ΔV is again applied. Show that the power delivered to the series configuration is $1/n^2$ times the power delivered to the parallel configuration.

81. In places such as hospital operating rooms or factories for electronic circuit boards, electric sparks must be avoided. A person standing on a grounded floor and touching nothing else can typically have a body capacitance of 150 pF , in parallel with a foot capacitance of 80.0 pF produced by the dielectric soles of his or her shoes. The person acquires static electric charge from interactions with his or her surroundings. The static charge flows to ground through the equivalent resistance of the two

shoe soles in parallel with each other. A pair of rubber-soled street shoes can present an equivalent resistance of $5.00 \times 10^3 \text{ M}\Omega$. A pair of shoes with special static-dissipative soles can have an equivalent resistance of $1.00 \text{ M}\Omega$. Consider the person's body and shoes as forming an RC circuit with the ground. (a) How long does it take the rubber-soled shoes to reduce a person's potential from $3.00 \times 10^3 \text{ V}$ to 100 V ? (b) How long does it take the static-dissipative shoes to do the same thing?

Challenge Problems

82. The switch in Figure P28.82a closes when $\Delta V_c > \frac{2}{3} \Delta V$ and opens when $\Delta V_c < \frac{1}{3} \Delta V$. The ideal voltmeter reads

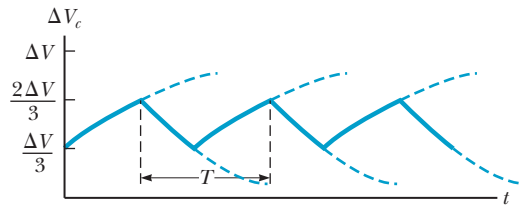
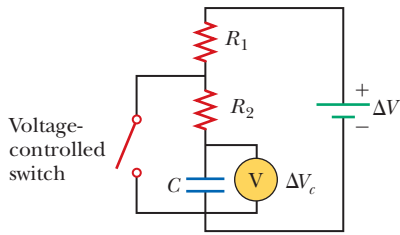

Figure P28.82

a potential difference as plotted in Figure P28.82b. What is the period T of the waveform in terms of R_1 , R_2 , and C ?

83. The resistor R in Figure P28.83 receives 20.0 W of power. Determine the value of R .

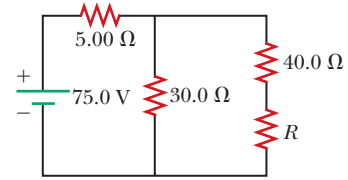
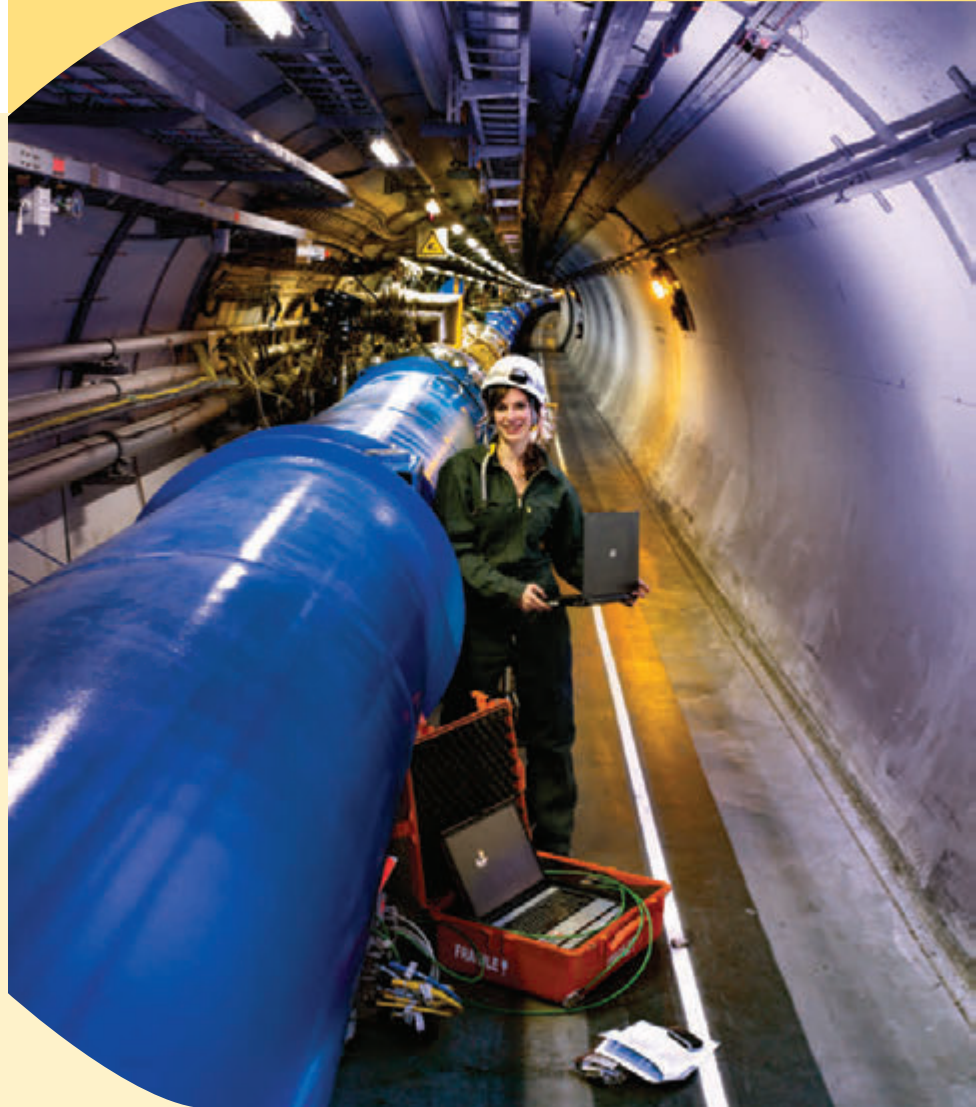

Figure P28.83

Magnetic Fields

- 29.1 Analysis Model: Particle in a Field (Magnetic)
- 29.2 Motion of a Charged Particle in a Uniform Magnetic Field
- 29.3 Applications Involving Charged Particles Moving in a Magnetic Field
- 29.4 Magnetic Force Acting on a Current-Carrying Conductor
- 29.5 Torque on a Current Loop in a Uniform Magnetic Field
- 29.6 The Hall Effect



An engineer performs a test on the electronics associated with one of the superconducting magnets in the Large Hadron Collider at the European Laboratory for Particle Physics, operated by the European Organization for Nuclear Research (CERN). The magnets are used to control the motion of charged particles in the accelerator. We will study the effects of magnetic fields on moving charged particles in this chapter. (CERN)

Many historians of science believe that the compass, which uses a magnetic needle, was used in China as early as the 13th century BC, its invention being of Arabic or Indian origin. The early Greeks knew about magnetism as early as 800 BC. They discovered that the stone magnetite (Fe_3O_4) attracts pieces of iron. Legend ascribes the name *magnetite* to the shepherd Magnes, the nails of whose shoes and the tip of whose staff stuck fast to chunks of magnetite while he pastured his flocks.

In 1269, Pierre de Maricourt of France found that the directions of a needle near a spherical natural magnet formed lines that encircled the sphere and passed through two points diametrically opposite each other, which he called the *poles* of the magnet. Subsequent experiments showed that every magnet, regardless of its shape, has two poles, called *north* (N) and *south* (S) poles, that exert forces on other magnetic poles similar to the way electric charges exert forces on one another. That is, like poles (N–N or S–S) repel each other, and opposite poles (N–S) attract each other.

The poles received their names because of the way a magnet, such as that in a compass, behaves in the presence of the Earth's magnetic field. If a bar magnet is suspended from its midpoint and can swing freely in a horizontal plane, it will rotate until its north pole points to the Earth's geographic North Pole and its south pole points to the Earth's geographic South Pole.¹

In 1600, William Gilbert (1540–1603) extended de Maricourt's experiments to a variety of materials. He knew that a compass needle orients in preferred directions, so he suggested that the Earth itself is a large, permanent magnet. In 1750, experimenters used a torsion balance to show that magnetic poles exert attractive or repulsive forces on each other and that these forces vary as the inverse square of the distance between interacting poles. Although the force between two magnetic poles is otherwise similar to the force between two electric charges, electric charges can be isolated (witness the electron and proton), whereas a single magnetic pole has never been isolated. That is, magnetic poles are always found in pairs. All attempts thus far to detect an isolated magnetic pole have been unsuccessful. No matter how many times a permanent magnet is cut in two, each piece always has a north and a south pole.²

The relationship between magnetism and electricity was discovered in 1819 when, during a lecture demonstration, Hans Christian Oersted found that an electric current in a wire deflected a nearby compass needle.³ In the 1820s, further connections between electricity and magnetism were demonstrated independently by Faraday and Joseph Henry (1797–1878). They showed that an electric current can be produced in a circuit either by moving a magnet near the circuit or by changing the current in a nearby circuit. These observations demonstrate that a changing magnetic field creates an electric field. Years later, theoretical work by Maxwell showed that the reverse is also true: a changing electric field creates a magnetic field.

This chapter examines the forces that act on moving charges and on current-carrying wires in the presence of a magnetic field. The source of the magnetic field is described in Chapter 30.

29.1 Analysis Model: Particle in a Field (Magnetic)

In our study of electricity, we described the interactions between charged objects in terms of electric fields. Recall that an electric field surrounds any electric charge. In addition to containing an electric field, the region of space surrounding any *moving* electric charge also contains a **magnetic field**. A magnetic field also surrounds a magnetic substance making up a permanent magnet.

Historically, the symbol $\vec{\mathbf{B}}$ has been used to represent a magnetic field, and we use this notation in this book. The direction of the magnetic field $\vec{\mathbf{B}}$ at any location is the direction in which a compass needle points at that location. As with the electric field, we can represent the magnetic field by means of drawings with *magnetic field lines*.

Figure 29.1 shows how the magnetic field lines of a bar magnet can be traced with the aid of a compass. Notice that the magnetic field lines outside the magnet



Hans Christian Oersted
Danish Physicist and Chemist
(1777–1851)

Oersted is best known for observing that a compass needle deflects when placed near a wire carrying a current. This important discovery was the first evidence of the connection between electric and magnetic phenomena. Oersted was also the first to prepare pure aluminum.

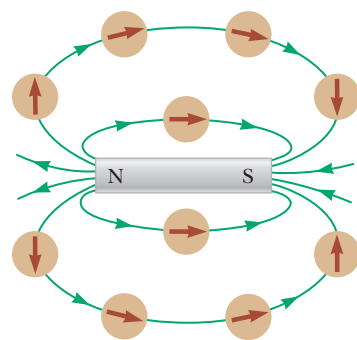

Figure 29.1 Compass needles can be used to trace the magnetic field lines in the region outside a bar magnet.

¹The Earth's geographic North Pole is magnetically a south pole, whereas the Earth's geographic South Pole is magnetically a north pole. Because *opposite* magnetic poles attract each other, the pole on a magnet that is attracted to the Earth's geographic North Pole is the magnet's *north* pole and the pole attracted to the Earth's geographic South Pole is the magnet's *south* pole.

²There is some theoretical basis for speculating that magnetic *monopoles*—isolated north or south poles—may exist in nature, and attempts to detect them are an active experimental field of investigation.

³The same discovery was reported in 1802 by an Italian jurist, Gian Domenico Romagnosi, but was overlooked, probably because it was published in an obscure journal.

Figure 29.2 Magnetic field patterns can be displayed with iron filings sprinkled on paper near magnets.

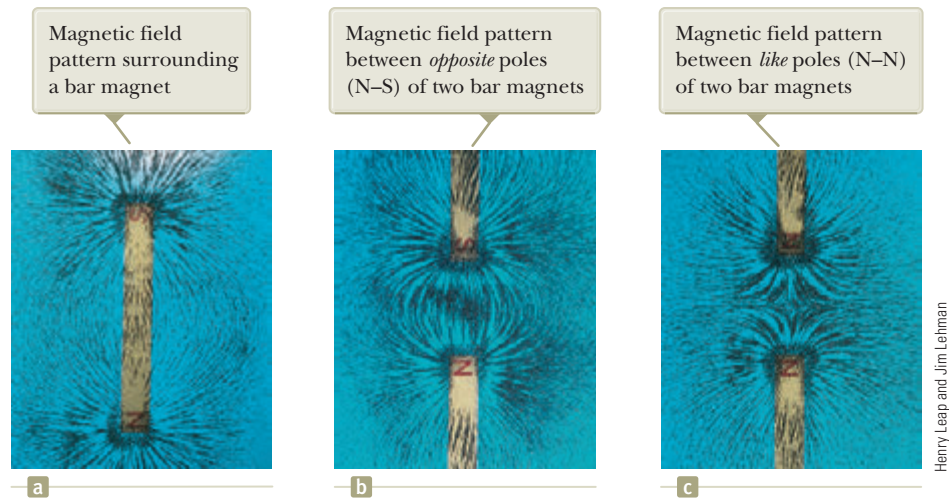

point away from the north pole and toward the south pole. One can display magnetic field patterns of a bar magnet using small iron filings as shown in Figure 29.2.

When we speak of a compass magnet having a north pole and a south pole, it is more proper to say that it has a “north-seeking” pole and a “south-seeking” pole. This wording means that the north-seeking pole points to the north geographic pole of the Earth, whereas the south-seeking pole points to the south geographic pole. Because the north pole of a magnet is attracted toward the north geographic pole of the Earth, the Earth’s south magnetic pole is located near the north geographic pole and the Earth’s north magnetic pole is located near the south geographic pole. In fact, the configuration of the Earth’s magnetic field, pictured in Figure 29.3, is very much like the one that would be achieved by burying a gigantic bar magnet deep in the Earth’s interior. If a compass needle is supported by bearings that allow it to rotate in the vertical plane as well as in the horizontal plane, the needle is horizontal with respect to the Earth’s surface only near the equator. As the compass is moved northward, the needle rotates so that it points more and more toward the Earth’s surface. Finally, at a point near Hudson Bay in Canada, the north pole of the needle points directly downward. This site, first found in 1832, is considered to be the location of the south magnetic pole of the Earth. It is approximately 1 300 mi from the Earth’s geographic

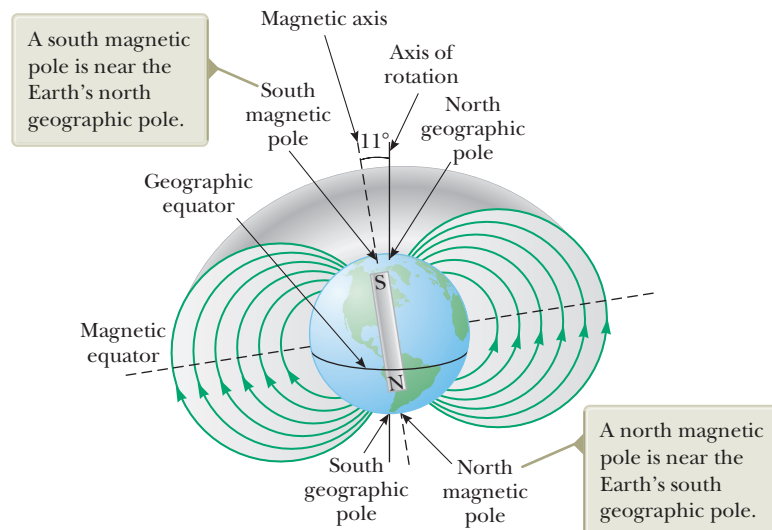

Figure 29.3 The Earth’s magnetic field lines.

North Pole, and its exact position varies slowly with time. Similarly, the north magnetic pole of the Earth is about 1 200 mi away from the Earth's geographic South Pole.

Although the Earth's magnetic field pattern is similar to the one that would be set up by a bar magnet deep within the Earth, it is easy to understand why the source of this magnetic field cannot be large masses of permanently magnetized material. The Earth does have large deposits of iron ore deep beneath its surface, but the high temperatures in the Earth's core prevent the iron from retaining any permanent magnetization. Scientists consider it more likely that the source of the Earth's magnetic field is convection currents in the Earth's core. Charged ions or electrons circulating in the liquid interior could produce a magnetic field just like a current loop does, as we shall see in Chapter 30. There is also strong evidence that the magnitude of a planet's magnetic field is related to the planet's rate of rotation. For example, Jupiter rotates faster than the Earth, and space probes indicate that Jupiter's magnetic field is stronger than the Earth's. Venus, on the other hand, rotates more slowly than the Earth, and its magnetic field is found to be weaker. Investigation into the cause of the Earth's magnetism is ongoing.

The direction of the Earth's magnetic field has reversed several times during the last million years. Evidence for this reversal is provided by basalt, a type of rock that contains iron. Basalt forms from material spewed forth by volcanic activity on the ocean floor. As the lava cools, it solidifies and retains a picture of the Earth's magnetic field direction. The rocks are dated by other means to provide a time line for these periodic reversals of the magnetic field.

We can quantify the magnetic field $\vec{\mathbf{B}}$ by using our model of a particle in a field, like the model discussed for gravity in Chapter 13 and for electricity in Chapter 23. The existence of a magnetic field at some point in space can be determined by measuring the **magnetic force** $\vec{\mathbf{F}}_B$ exerted on an appropriate test particle placed at that point. This process is the same one we followed in defining the electric field in Chapter 23. If we perform such an experiment by placing a particle with charge q in the magnetic field, we find the following results that are similar to those for experiments on electric forces:

- The magnetic force is proportional to the charge q of the particle.
- The magnetic force on a negative charge is directed opposite to the force on a positive charge moving in the same direction.
- The magnetic force is proportional to the magnitude of the magnetic field vector $\vec{\mathbf{B}}$.

We also find the following results, which are *totally different* from those for experiments on electric forces:

- The magnetic force is proportional to the speed v of the particle.
- If the velocity vector makes an angle θ with the magnetic field, the magnitude of the magnetic force is proportional to $\sin \theta$.
- When a charged particle moves *parallel* to the magnetic field vector, the magnetic force on the charge is zero.
- When a charged particle moves in a direction *not* parallel to the magnetic field vector, the magnetic force acts in a direction perpendicular to both $\vec{\mathbf{v}}$ and $\vec{\mathbf{B}}$; that is, the magnetic force is perpendicular to the plane formed by $\vec{\mathbf{v}}$ and $\vec{\mathbf{B}}$.

These results show that the magnetic force on a particle is more complicated than the electric force. The magnetic force is distinctive because it depends on the velocity of the particle and because its direction is perpendicular to both $\vec{\mathbf{v}}$ and $\vec{\mathbf{B}}$. Figure 29.4 (page 872) shows the details of the direction of the magnetic force on a charged

Figure 29.4 (a) The direction of the magnetic force \vec{F}_B acting on a charged particle moving with a velocity \vec{v} in the presence of a magnetic field \vec{B} . (b) Magnetic forces on positive and negative charges. The dashed lines show the paths of the particles, which are investigated in Section 29.2.

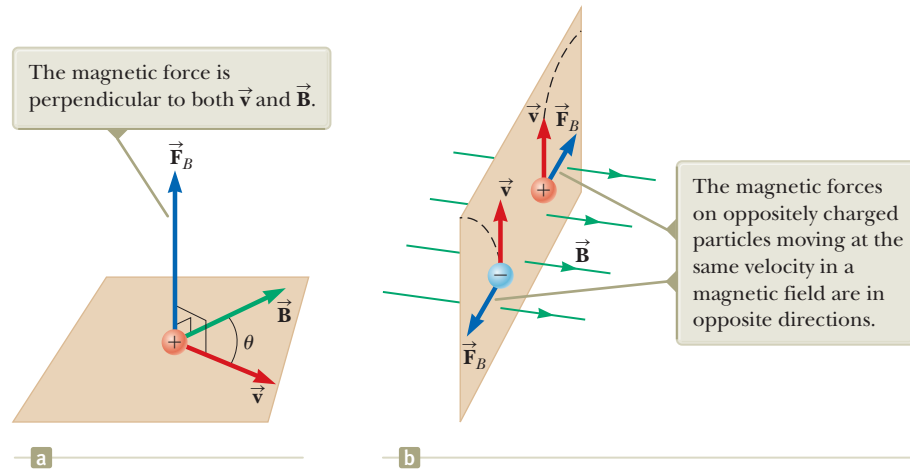

particle. Despite this complicated behavior, these observations can be summarized in a compact way by writing the magnetic force in the form

$$\vec{F}_B = q\vec{v} \times \vec{B} \quad (29.1)$$

Vector expression for the magnetic force on a charged particle moving in a magnetic field

which by definition of the cross product (see Section 11.1) is perpendicular to both \vec{v} and \vec{B} . We can regard this equation as an operational definition of the magnetic field at some point in space. That is, the magnetic field is defined in terms of the force acting on a moving charged particle. Equation 29.1 is the mathematical representation of the magnetic version of the **particle in a field** analysis model.

Figure 29.5 reviews two right-hand rules for determining the direction of the cross product $\vec{v} \times \vec{B}$ and determining the direction of \vec{F}_B . The rule in Figure 29.5a depends on our right-hand rule for the cross product in Figure 11.2. Point the four fingers of your right hand along the direction of \vec{v} with the palm facing \vec{B} and curl them toward \vec{B} . Your extended thumb, which is at a right angle to your fingers, points in the direction of $\vec{v} \times \vec{B}$. Because $\vec{F}_B = q\vec{v} \times \vec{B}$, \vec{F}_B is in the direction of your thumb if q is positive and is opposite the direction of your thumb if q is negative. (If you need more help understanding the cross product, you should review Section 11.1, including Fig. 11.2.)

An alternative rule is shown in Figure 29.5b. Here the thumb points in the direction of \vec{v} and the extended fingers in the direction of \vec{B} . Now, the force \vec{F}_B on a positive charge extends outward from the palm. The advantage of this rule is that the force on the charge is in the direction you would push on something with your

Figure 29.5 Two right-hand rules for determining the direction of the magnetic force $\vec{F}_B = q\vec{v} \times \vec{B}$ acting on a particle with charge q moving with a velocity \vec{v} in a magnetic field \vec{B} . (a) In this rule, the magnetic force is in the direction in which your thumb points. (b) In this rule, the magnetic force is in the direction of your palm, as if you are pushing the particle with your hand.

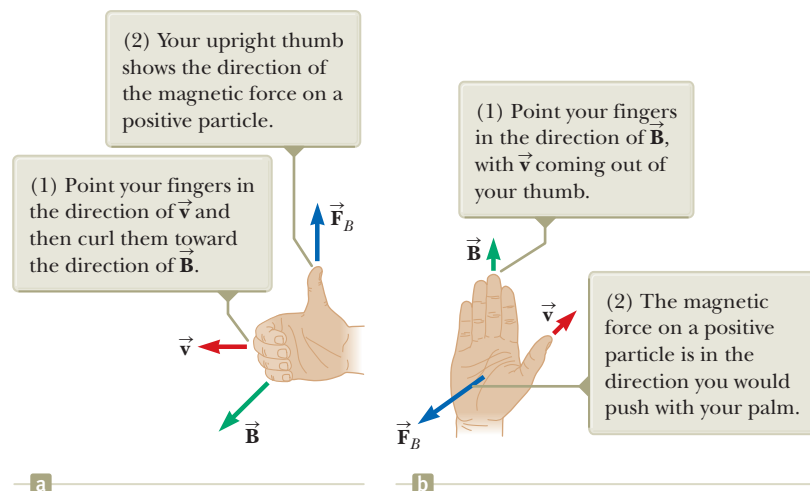

hand: outward from your palm. The force on a negative charge is in the opposite direction. You can use either of these two right-hand rules.

The magnitude of the magnetic force on a charged particle is

$$F_B = |q|vB \sin \theta \quad (29.2)$$

where θ is the smaller angle between \vec{v} and \vec{B} . From this expression, we see that F_B is zero when \vec{v} is parallel or antiparallel to \vec{B} ($\theta = 0$ or 180°) and maximum when \vec{v} is perpendicular to \vec{B} ($\theta = 90^\circ$).

Let's compare the important differences between the electric and magnetic versions of the particle in a field model:

- The electric force vector is along the direction of the electric field, whereas the magnetic force vector is perpendicular to the magnetic field.
- The electric force acts on a charged particle regardless of whether the particle is moving, whereas the magnetic force acts on a charged particle only when the particle is in motion.
- The electric force does work in displacing a charged particle, whereas the magnetic force associated with a steady magnetic field does no work when a particle is displaced because the force is perpendicular to the displacement of its point of application.

From the last statement and on the basis of the work–kinetic energy theorem, we conclude that the kinetic energy of a charged particle moving through a magnetic field cannot be altered by the magnetic field alone. The field can alter the direction of the velocity vector, but it cannot change the speed or kinetic energy of the particle.

From Equation 29.2, we see that the SI unit of magnetic field is the newton per coulomb-meter per second, which is called the **tesla** (T):

$$1 \text{ T} = 1 \frac{\text{N}}{\text{C} \cdot \text{m/s}}$$

Because a coulomb per second is defined to be an ampere,

$$1 \text{ T} = 1 \frac{\text{N}}{\text{A} \cdot \text{m}}$$

A non-SI magnetic-field unit in common use, called the *gauss* (G), is related to the tesla through the conversion $1 \text{ T} = 10^4 \text{ G}$. Table 29.1 shows some typical values of magnetic fields.

- Quick Quiz 29.1** An electron moves in the plane of this paper toward the top of the page. A magnetic field is also in the plane of the page and directed toward the right. What is the direction of the magnetic force on the electron? (a) toward the top of the page (b) toward the bottom of the page (c) toward the left edge of the page (d) toward the right edge of the page (e) upward out of the page (f) downward into the page

Table 29.1 Some Approximate Magnetic Field Magnitudes

Source of Field	Field Magnitude (T)
Strong superconducting laboratory magnet	30
Strong conventional laboratory magnet	2
Medical MRI unit	1.5
Bar magnet	10^{-2}
Surface of the Sun	10^{-2}
Surface of the Earth	0.5×10^{-4}
Inside human brain (due to nerve impulses)	10^{-13}

◀ Magnitude of the magnetic force on a charged particle moving in a magnetic field

◀ The tesla

Analysis Model Particle in a Field (Magnetic)

Imagine some source (which we will investigate later) establishes a **magnetic field** \vec{B} throughout space. Now imagine a particle with charge q is placed in that field. The particle interacts with the magnetic field so that the particle experiences a magnetic force given by

$$\vec{F}_B = q\vec{v} \times \vec{B} \quad (29.1)$$

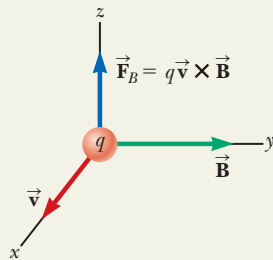

Examples:

- an ion moves in a circular path in the magnetic field of a mass spectrometer (Section 29.3)
- a coil in a motor rotates in response to the magnetic field in the motor (Chapter 31)
- a magnetic field is used to separate particles emitted by radioactive sources (Chapter 44)
- in a bubble chamber, particles created in collisions follow curved paths in a magnetic field, allowing the particles to be identified (Chapter 46)

Example 29.1 An Electron Moving in a Magnetic Field

AM

An electron in an old-style television picture tube moves toward the front of the tube with a speed of 8.0×10^6 m/s along the x axis (Fig. 29.6). Surrounding the neck of the tube are coils of wire that create a magnetic field of magnitude 0.025 T, directed at an angle of 60° to the x axis and lying in the xy plane. Calculate the magnetic force on the electron.

SOLUTION

Conceptualize Recall that the magnetic force on a charged particle is perpendicular to the plane formed by the velocity and magnetic field vectors. Use one of the right-hand rules in Figure 29.5 to convince yourself that the direction of the force on the electron is downward in Figure 29.6.

Categorize We evaluate the magnetic force using the *magnetic* version of the *particle in a field* model.

Analyze Use Equation 29.2 to find the magnitude of the magnetic force:

$$\begin{aligned} F_B &= |q|vB \sin \theta \\ &= (1.6 \times 10^{-19} \text{ C})(8.0 \times 10^6 \text{ m/s})(0.025 \text{ T})(\sin 60^\circ) \\ &= 2.8 \times 10^{-14} \text{ N} \end{aligned}$$

Finalize For practice using the vector product, evaluate this force in vector notation using Equation 29.1. The magnitude of the magnetic force may seem small to you, but remember that it is acting on a very small particle, the electron. To convince yourself that this is a substantial force for an electron, calculate the initial acceleration of the electron due to this force.

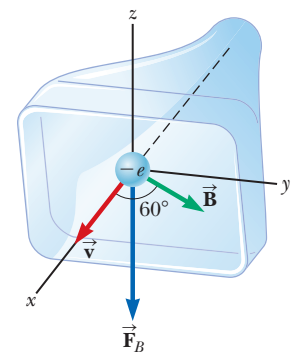

Figure 29.6 (Example 29.1) The magnetic force \vec{F}_B acting on the electron is in the negative z direction when \vec{v} and \vec{B} lie in the xy plane.

29.2 Motion of a Charged Particle in a Uniform Magnetic Field

Before we continue our discussion, some explanation of the notation used in this book is in order. To indicate the direction of \vec{B} in illustrations, we sometimes present perspective views such as those in Figure 29.6. If \vec{B} lies in the plane of the page or is present in a perspective drawing, we use green vectors or green field lines with arrowheads. In nonperspective illustrations, we depict a magnetic field perpendicular to and directed out of the page with a series of green dots, which represent the tips of arrows coming toward you (see Fig. 29.7a). In this case, the field is labeled

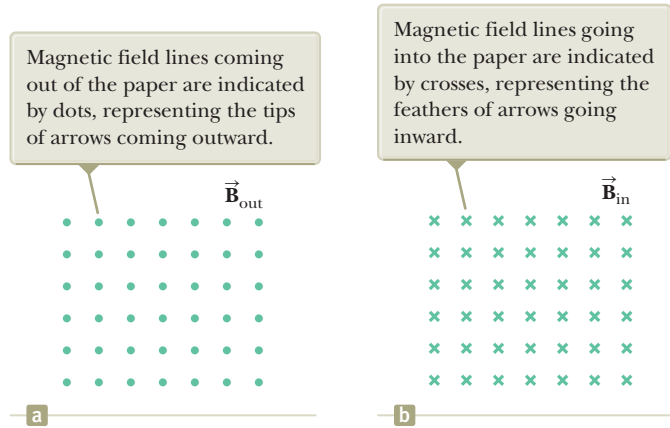

Figure 29.7 Representations of magnetic field lines perpendicular to the page.

\vec{B}_{out} . If \vec{B} is directed perpendicularly into the page, we use green crosses, which represent the feathered tails of arrows fired away from you, as in Figure 29.7b. In this case, the field is labeled \vec{B}_{in} , where the subscript “in” indicates “into the page.” The same notation with crosses and dots is also used for other quantities that might be perpendicular to the page such as forces and current directions.

In Section 29.1, we found that the magnetic force acting on a charged particle moving in a magnetic field is perpendicular to the particle’s velocity and consequently the work done by the magnetic force on the particle is zero. Now consider the special case of a positively charged particle moving in a uniform magnetic field with the initial velocity vector of the particle perpendicular to the field. Let’s assume the direction of the magnetic field is into the page as in Figure 29.8. The particle in a field model tells us that the magnetic force on the particle is perpendicular to both the magnetic field lines and the velocity of the particle. The fact that there is a force on the particle tells us to apply the particle under a net force model to the particle. As the particle changes the direction of its velocity in response to the magnetic force, the magnetic force remains perpendicular to the velocity. As we found in Section 6.1, if the force is always perpendicular to the velocity, the path of the particle is a circle! Figure 29.8 shows the particle moving in a circle in a plane perpendicular to the magnetic field. Although magnetism and magnetic forces may be new and unfamiliar to you now, we see a magnetic effect that results in something with which we are familiar: the particle in uniform circular motion model!

The particle moves in a circle because the magnetic force \vec{F}_B is perpendicular to \vec{v} and \vec{B} and has a constant magnitude qvB . As Figure 29.8 illustrates, the

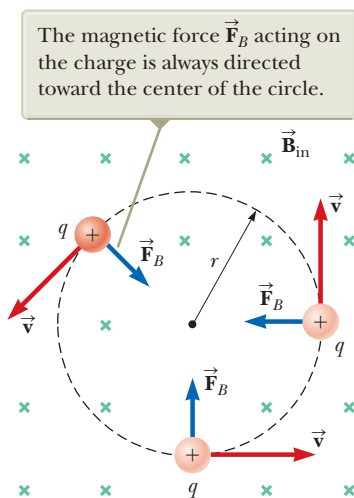

Figure 29.8 When the velocity of a charged particle is perpendicular to a uniform magnetic field, the particle moves in a circular path in a plane perpendicular to \vec{B} .

rotation is counterclockwise for a positive charge in a magnetic field directed into the page. If q were negative, the rotation would be clockwise. We use the particle under a net force model to write Newton's second law for the particle:

$$\sum F = F_B = ma$$

Because the particle moves in a circle, we also model it as a particle in uniform circular motion and we replace the acceleration with centripetal acceleration:

$$F_B = qvB = \frac{mv^2}{r}$$

This expression leads to the following equation for the radius of the circular path:

$$r = \frac{mv}{qB} \quad (29.3)$$

That is, the radius of the path is proportional to the linear momentum mv of the particle and inversely proportional to the magnitude of the charge on the particle and to the magnitude of the magnetic field. The angular speed of the particle (from Eq. 10.10) is

$$\omega = \frac{v}{r} = \frac{qB}{m} \quad (29.4)$$

The period of the motion (the time interval the particle requires to complete one revolution) is equal to the circumference of the circle divided by the speed of the particle:

$$T = \frac{2\pi r}{v} = \frac{2\pi}{\omega} = \frac{2\pi m}{qB} \quad (29.5)$$

These results show that the angular speed of the particle and the period of the circular motion do not depend on the speed of the particle or on the radius of the orbit. The angular speed ω is often referred to as the **cyclotron frequency** because charged particles circulate at this angular frequency in the type of accelerator called a *cyclotron*, which is discussed in Section 29.3.

If a charged particle moves in a uniform magnetic field with its velocity at some arbitrary angle with respect to $\vec{\mathbf{B}}$, its path is a helix. For example, if the field is directed in the x direction as shown in Figure 29.9, there is no component of force in the x direction. As a result, $a_x = 0$, and the x component of velocity remains constant. The charged particle is a particle in equilibrium in this direction. The magnetic force $q\vec{\mathbf{v}} \times \vec{\mathbf{B}}$ causes the components v_y and v_z to change in time, however, and the resulting motion is a helix whose axis is parallel to the magnetic field. The projection of the path onto the yz plane (viewed along the x axis) is a circle. (The projections of the path onto the xy and xz planes are sinusoids!) Equations 29.3 to 29.5 still apply provided v is replaced by $v_{\perp} = \sqrt{v_y^2 + v_z^2}$.

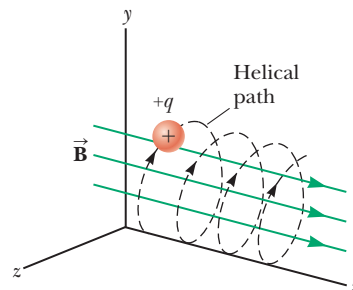

Figure 29.9 A charged particle having a velocity vector that has a component parallel to a uniform magnetic field moves in a helical path.

- Quick Quiz 29.2** A charged particle is moving perpendicular to a magnetic field in a circle with a radius r . (i) An identical particle enters the field, with \vec{v} perpendicular to \vec{B} , but with a higher speed than the first particle. Compared with the radius of the circle for the first particle, is the radius of the circular path for the second particle (a) smaller, (b) larger, or (c) equal in size? (ii) The magnitude of the magnetic field is increased. From the same choices, compare the radius of the new circular path of the first particle with the radius of its initial path.

Example 29.2 A Proton Moving Perpendicular to a Uniform Magnetic Field AM

A proton is moving in a circular orbit of radius 14 cm in a uniform 0.35-T magnetic field perpendicular to the velocity of the proton. Find the speed of the proton.

SOLUTION

Conceptualize From our discussion in this section, we know the proton follows a circular path when moving perpendicular to a uniform magnetic field. In Chapter 39, we will learn that the highest possible speed for a particle is the speed of light, 3.00×10^8 m/s, so the speed of the particle in this problem must come out to be smaller than that value.

Categorize The proton is described by both the *particle in a field* model and the *particle in uniform circular motion* model. These models led to Equation 29.3.

Analyze

Solve Equation 29.3 for the speed of the particle:

$$v = \frac{qBr}{m_p}$$

Substitute numerical values:

$$\begin{aligned} v &= \frac{(1.60 \times 10^{-19} \text{ C})(0.35 \text{ T})(0.14 \text{ m})}{1.67 \times 10^{-27} \text{ kg}} \\ &= 4.7 \times 10^6 \text{ m/s} \end{aligned}$$

Finalize The speed is indeed smaller than the speed of light, as required.

WHAT IF? What if an electron, rather than a proton, moves in a direction perpendicular to the same magnetic field with this same speed? Will the radius of its orbit be different?

Answer An electron has a much smaller mass than a proton, so the magnetic force should be able to change its velocity much more easily than that for the proton. Therefore, we expect the radius to be smaller. Equation 29.3 shows that r is proportional to m with q , B , and v the same for the electron as for the proton. Consequently, the radius will be smaller by the same factor as the ratio of masses m_e/m_p .

Example 29.3 Bending an Electron Beam AM

In an experiment designed to measure the magnitude of a uniform magnetic field, electrons are accelerated from rest through a potential difference of 350 V and then enter a uniform magnetic field that is perpendicular to the velocity vector of the electrons. The electrons travel along a curved path because of the magnetic force exerted on them, and the radius of the path is measured to be 7.5 cm. (Such a curved beam of electrons is shown in Fig. 29.10.)

(A) What is the magnitude of the magnetic field?

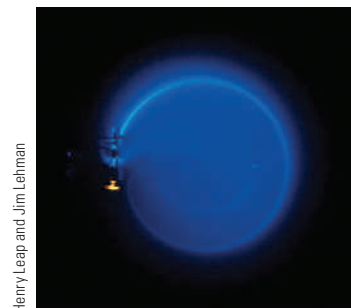

Henry Leap and Jim Lehman

Figure 29.10 (Example 29.3) The bending of an electron beam in a magnetic field.

continued

▶ 29.3 continued

SOLUTION

Conceptualize This example involves electrons accelerating from rest due to an electric force and then moving in a circular path due to a magnetic force. With the help of Figures 29.8 and 29.10, visualize the circular motion of the electrons.

Categorize Equation 29.3 shows that we need the speed v of the electron to find the magnetic field magnitude, and v is not given. Consequently, we must find the speed of the electron based on the potential difference through which it is accelerated. To do so, we categorize the first part of the problem by modeling an electron and the electric field as an *isolated system* in terms of *energy*. Once the electron enters the magnetic field, we categorize the second part of the problem as one involving a *particle in a field* and a *particle in uniform circular motion*, as we have done in this section.

Analyze Write the appropriate reduction of the conservation of energy equation, Equation 8.2, for the electron–electric field system:

$$\Delta K + \Delta U = 0$$

Substitute the appropriate initial and final energies:

$$\left(\frac{1}{2}m_e v^2 - 0\right) + (q\Delta V) = 0$$

Solve for the speed of the electron:

$$v = \sqrt{\frac{-2q\Delta V}{m_e}}$$

Substitute numerical values:

$$v = \sqrt{\frac{-2(-1.60 \times 10^{-19} \text{ C})(350 \text{ V})}{9.11 \times 10^{-31} \text{ kg}}} = 1.11 \times 10^7 \text{ m/s}$$

Now imagine the electron entering the magnetic field with this speed. Solve Equation 29.3 for the magnitude of the magnetic field:

$$B = \frac{m_e v}{er}$$

Substitute numerical values:

$$B = \frac{(9.11 \times 10^{-31} \text{ kg})(1.11 \times 10^7 \text{ m/s})}{(1.60 \times 10^{-19} \text{ C})(0.075 \text{ m})} = 8.4 \times 10^{-4} \text{ T}$$

(B) What is the angular speed of the electrons?

SOLUTION

Use Equation 10.10:

$$\omega = \frac{v}{r} = \frac{1.11 \times 10^7 \text{ m/s}}{0.075 \text{ m}} = 1.5 \times 10^8 \text{ rad/s}$$

Finalize The angular speed can be represented as $\omega = (1.5 \times 10^8 \text{ rad/s})(1 \text{ rev}/2\pi \text{ rad}) = 2.4 \times 10^7 \text{ rev/s}$. The electrons travel around the circle 24 million times per second! This answer is consistent with the very high speed found in part (A).

WHAT IF? What if a sudden voltage surge causes the accelerating voltage to increase to 400 V? How does that affect the angular speed of the electrons, assuming the magnetic field remains constant?

Answer The increase in accelerating voltage ΔV causes the electrons to enter the magnetic field with a higher speed v . This higher speed causes them to travel in a circle with a larger radius r . The angular speed is the ratio of v to r . Both v and r increase by the same factor, so the effects can-

cel and the angular speed remains the same. Equation 29.4 is an expression for the cyclotron frequency, which is the same as the angular speed of the electrons. The cyclotron frequency depends only on the charge q , the magnetic field B , and the mass m_e , none of which have changed. Therefore, the voltage surge has no effect on the angular speed. (In reality, however, the voltage surge may also increase the magnetic field if the magnetic field is powered by the same source as the accelerating voltage. In that case, the angular speed increases according to Eq. 29.4.)

When charged particles move in a nonuniform magnetic field, the motion is complex. For example, in a magnetic field that is strong at the ends and weak in the middle such as that shown in Figure 29.11, the particles can oscillate between two positions. A charged particle starting at one end spirals along the field lines until it reaches the other end, where it reverses its path and spirals back. This configura-

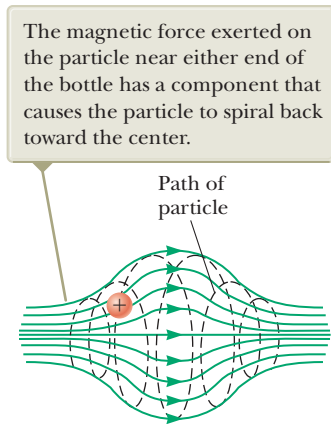

Figure 29.11 A charged particle moving in a nonuniform magnetic field (a magnetic bottle) spirals about the field and oscillates between the endpoints.

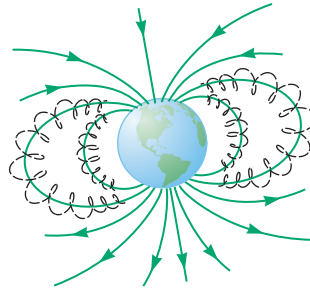

Figure 29.12 The Van Allen belts are made up of charged particles trapped by the Earth's nonuniform magnetic field. The magnetic field lines are in green, and the particle paths are dashed black lines.

tion is known as a *magnetic bottle* because charged particles can be trapped within it. The magnetic bottle has been used to confine a *plasma*, a gas consisting of ions and electrons. Such a plasma-confinement scheme could fulfill a crucial role in the control of nuclear fusion, a process that could supply us in the future with an almost endless source of energy. Unfortunately, the magnetic bottle has its problems. If a large number of particles are trapped, collisions between them cause the particles to eventually leak from the system.

The Van Allen radiation belts consist of charged particles (mostly electrons and protons) surrounding the Earth in doughnut-shaped regions (Fig. 29.12). The particles, trapped by the Earth's nonuniform magnetic field, spiral around the field lines from pole to pole, covering the distance in only a few seconds. These particles originate mainly from the Sun, but some come from stars and other heavenly objects. For this reason, the particles are called *cosmic rays*. Most cosmic rays are deflected by the Earth's magnetic field and never reach the atmosphere. Some of the particles become trapped, however, and it is these particles that make up the Van Allen belts. When the particles are located over the poles, they sometimes collide with atoms in the atmosphere, causing the atoms to emit visible light. Such collisions are the origin of the beautiful aurora borealis, or northern lights, in the northern hemisphere and the aurora australis in the southern hemisphere. Auroras are usually confined to the polar regions because the Van Allen belts are nearest the Earth's surface there. Occasionally, though, solar activity causes larger numbers of charged particles to enter the belts and significantly distort the normal magnetic field lines associated with the Earth. In these situations, an aurora can sometimes be seen at lower latitudes.

29.3 Applications Involving Charged Particles Moving in a Magnetic Field

A charge moving with a velocity \vec{v} in the presence of both an electric field \vec{E} and a magnetic field \vec{B} is described by two particle in a field models. It experiences both an electric force $q\vec{E}$ and a magnetic force $q\vec{v} \times \vec{B}$. The total force (called the Lorentz force) acting on the charge is

$$\vec{F} = q\vec{E} + q\vec{v} \times \vec{B} \quad (29.6)$$

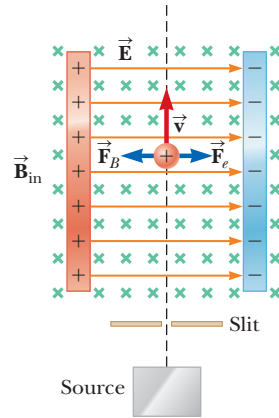

Figure 29.13 A velocity selector. When a positively charged particle is moving with velocity \vec{v} in the presence of a magnetic field directed into the page and an electric field directed to the right, it experiences an electric force $q\vec{E}$ to the right and a magnetic force $q\vec{v} \times \vec{B}$ to the left.

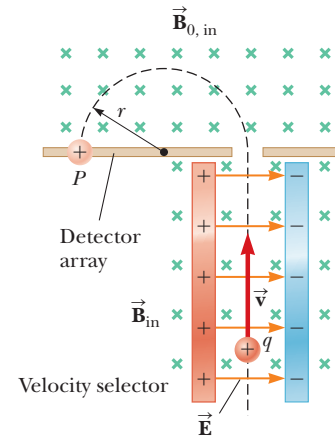

Figure 29.14 A mass spectrometer. Positively charged particles are sent first through a velocity selector and then into a region where the magnetic field \vec{B}_0 causes the particles to move in a semicircular path and strike a detector array at P .

Velocity Selector

In many experiments involving moving charged particles, it is important that all particles move with essentially the same velocity, which can be achieved by applying a combination of an electric field and a magnetic field oriented as shown in Figure 29.13. A uniform electric field is directed to the right (in the plane of the page in Fig. 29.13), and a uniform magnetic field is applied in the direction perpendicular to the electric field (into the page in Fig. 29.13). If q is positive and the velocity \vec{v} is upward, the magnetic force $q\vec{v} \times \vec{B}$ is to the left and the electric force $q\vec{E}$ is to the right. When the magnitudes of the two fields are chosen so that $qE = qvB$, the forces cancel. The charged particle is modeled as a particle in equilibrium and moves in a straight vertical line through the region of the fields. From the expression $qE = qvB$, we find that

$$v = \frac{E}{B} \quad (29.7)$$

Only those particles having this speed pass undeflected through the mutually perpendicular electric and magnetic fields. The magnetic force exerted on particles moving at speeds greater than that is stronger than the electric force, and the particles are deflected to the left. Those moving at slower speeds are deflected to the right.

The Mass Spectrometer

A **mass spectrometer** separates ions according to their mass-to-charge ratio. In one version of this device, known as the *Bainbridge mass spectrometer*, a beam of ions first passes through a velocity selector and then enters a second uniform magnetic field \vec{B}_0 that has the same direction as the magnetic field in the selector (Fig. 29.14). Upon entering the second magnetic field, the ions are described by the particle in uniform circular motion model. They move in a semicircle of radius r before striking a detector array at P . If the ions are positively charged, the beam deflects to the left as Figure 29.14 shows. If the ions are negatively charged, the beam deflects to the right. From Equation 29.3, we can express the ratio m/q as

$$\frac{m}{q} = \frac{rB_0}{v}$$

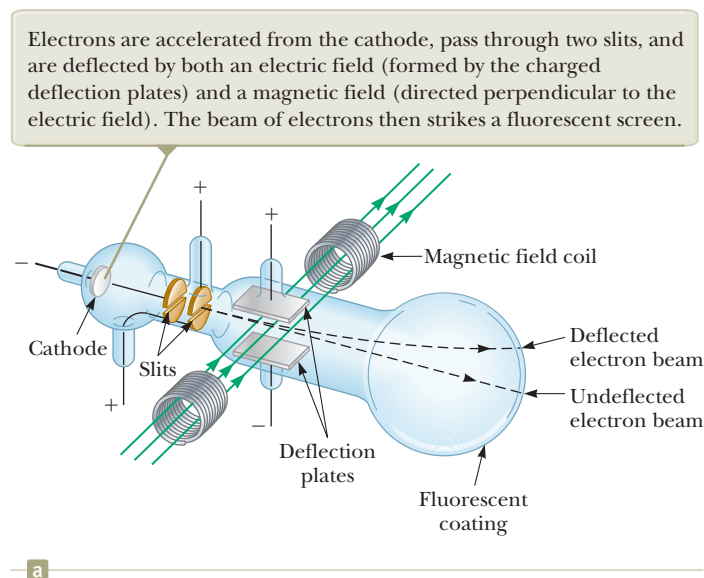

Lucent Technologies Bell Laboratory, courtesy AIP
Emilio Segre Visual Archives

Figure 29.15 (a) Thomson's apparatus for measuring e/m_e . (b) J. J. Thomson (left) in the Cavendish Laboratory, University of Cambridge. The man on the right, Frank Baldwin Jewett, is a distant relative of John W. Jewett, Jr., coauthor of this text.

Using Equation 29.7 gives

$$\frac{m}{q} = \frac{rB_0B}{E} \quad (29.8)$$

Therefore, we can determine m/q by measuring the radius of curvature and knowing the field magnitudes B , B_0 , and E . In practice, one usually measures the masses of various isotopes of a given ion, with the ions all carrying the same charge q . In this way, the mass ratios can be determined even if q is unknown.

A variation of this technique was used by J. J. Thomson (1856–1940) in 1897 to measure the ratio e/m_e for electrons. Figure 29.15a shows the basic apparatus he used. Electrons are accelerated from the cathode and pass through two slits. They then drift into a region of perpendicular electric and magnetic fields. The magnitudes of the two fields are first adjusted to produce an undeflected beam. When the magnetic field is turned off, the electric field produces a measurable beam deflection that is recorded on the fluorescent screen. From the size of the deflection and the measured values of E and B , the charge-to-mass ratio can be determined. The results of this crucial experiment represent the discovery of the electron as a fundamental particle of nature.

The Cyclotron

A **cyclotron** is a device that can accelerate charged particles to very high speeds. The energetic particles produced are used to bombard atomic nuclei and thereby produce nuclear reactions of interest to researchers. A number of hospitals use cyclotron facilities to produce radioactive substances for diagnosis and treatment.

Both electric and magnetic forces play key roles in the operation of a cyclotron, a schematic drawing of which is shown in Figure 29.16a (page 882). The charges move inside two semicircular containers D_1 and D_2 , referred to as *dees* because of their shape like the letter D. A high-frequency alternating potential difference is applied to the dees, and a uniform magnetic field is directed perpendicular to them. A positive ion released at P near the center of the magnet in one dee moves in a semicircular path (indicated by the dashed black line in the drawing) and arrives back at the gap in a time interval $T/2$, where T is the time interval needed to make one complete trip around the two dees, given by Equation 29.5. The frequency

Pitfall Prevention 29.1

The Cyclotron Is Not the Only Type of Particle Accelerator The cyclotron is important historically because it was the first particle accelerator to produce particles with very high speeds. Cyclotrons still play important roles in medical applications and some research activities. Many other research activities make use of a different type of accelerator called a *synchrotron*.

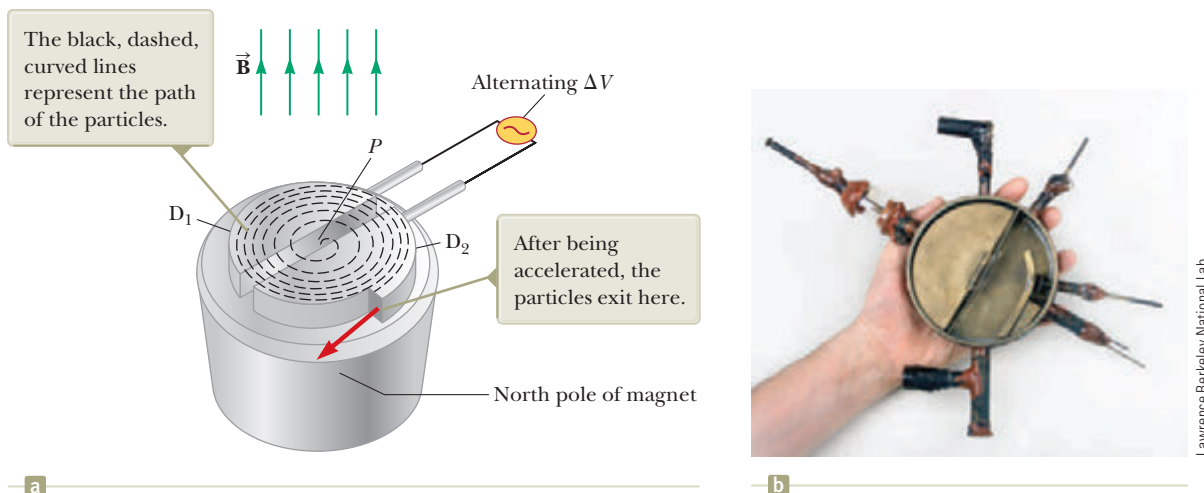

Figure 29.16 (a) A cyclotron consists of an ion source at P , two dees D_1 and D_2 across which an alternating potential difference is applied, and a uniform magnetic field. (The south pole of the magnet is not shown.) (b) The first cyclotron, invented by E. O. Lawrence and M. S. Livingston in 1934.

of the applied potential difference is adjusted so that the polarity of the dees is reversed in the same time interval during which the ion travels around one dee. If the applied potential difference is adjusted such that D_1 is at a lower electric potential than D_2 by an amount ΔV , the ion accelerates across the gap to D_1 and its kinetic energy increases by an amount $q \Delta V$. It then moves around D_1 in a semicircular path of greater radius (because its speed has increased). After a time interval $T/2$, it again arrives at the gap between the dees. By this time, the polarity across the dees has again been reversed and the ion is given another “kick” across the gap. The motion continues so that for each half-circle trip around one dee, the ion gains additional kinetic energy equal to $q \Delta V$. When the radius of its path is nearly that of the dees, the energetic ion leaves the system through the exit slit. The cyclotron’s operation depends on T being independent of the speed of the ion and of the radius of the circular path (Eq. 29.5).

We can obtain an expression for the kinetic energy of the ion when it exits the cyclotron in terms of the radius R of the dees. From Equation 29.3, we know that $v = qBR/m$. Hence, the kinetic energy is

$$K = \frac{1}{2}mv^2 = \frac{q^2 B^2 R^2}{2m} \quad (29.9)$$

When the energy of the ions in a cyclotron exceeds about 20 MeV, relativistic effects come into play. (Such effects are discussed in Chapter 39.) Observations show that T increases and the moving ions do not remain in phase with the applied potential difference. Some accelerators overcome this problem by modifying the period of the applied potential difference so that it remains in phase with the moving ions.

29.4 Magnetic Force Acting on a Current-Carrying Conductor

If a magnetic force is exerted on a single charged particle when the particle moves through a magnetic field, it should not surprise you that a current-carrying wire also experiences a force when placed in a magnetic field. The current is a collection of many charged particles in motion; hence, the resultant force exerted by the field on the wire is the vector sum of the individual forces exerted on all the charged particles making up the current. The force exerted on the particles is transmitted to the wire when the particles collide with the atoms making up the wire.

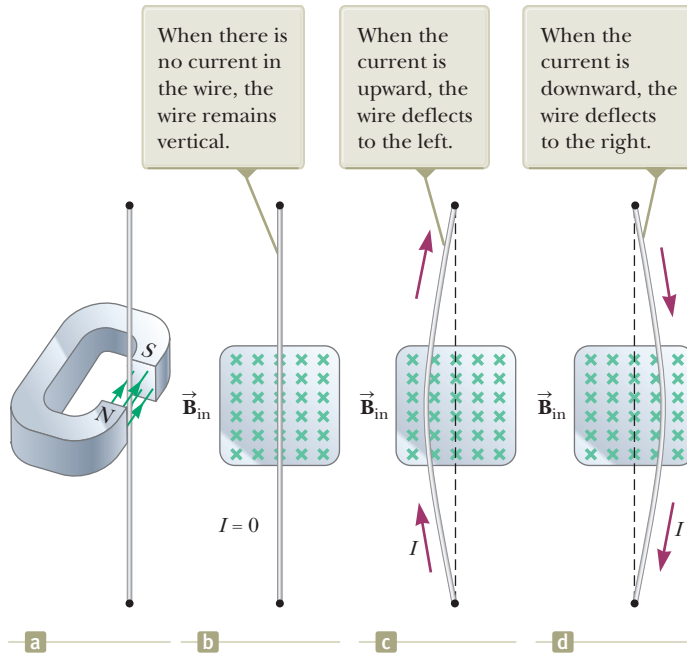

Figure 29.17 (a) A wire suspended vertically between the poles of a magnet. (b)–(d) The setup shown in (a) as seen looking at the south pole of the magnet so that the magnetic field (green crosses) is directed into the page.

One can demonstrate the magnetic force acting on a current-carrying conductor by hanging a wire between the poles of a magnet as shown in Figure 29.17a. For ease in visualization, part of the horseshoe magnet in part (a) is removed to show the end face of the south pole in parts (b) through (d) of Figure 29.17. The magnetic field is directed into the page and covers the region within the shaded squares. When the current in the wire is zero, the wire remains vertical as in Figure 29.17b. When the wire carries a current directed upward as in Figure 29.17c, however, the wire deflects to the left. If the current is reversed as in Figure 29.17d, the wire deflects to the right.

Let's quantify this discussion by considering a straight segment of wire of length L and cross-sectional area A carrying a current I in a uniform magnetic field \vec{B} as in Figure 29.18. According to the magnetic version of the particle in a field model, the magnetic force exerted on a charge q moving with a drift velocity \vec{v}_d is $q\vec{v}_d \times \vec{B}$. To find the total force acting on the wire, we multiply the force $q\vec{v}_d \times \vec{B}$ exerted on one charge by the number of charges in the segment. Because the volume of the segment is AL , the number of charges in the segment is nAL , where n is the number of mobile charge carriers per unit volume. Hence, the total magnetic force on the segment of wire of length L is

$$\vec{F}_B = (q\vec{v}_d \times \vec{B})nAL$$

We can write this expression in a more convenient form by noting that, from Equation 27.4, the current in the wire is $I = nqv_dA$. Therefore,

$$\vec{F}_B = I\vec{L} \times \vec{B} \tag{29.10}$$

where \vec{L} is a vector that points in the direction of the current I and has a magnitude equal to the length L of the segment. This expression applies only to a straight segment of wire in a uniform magnetic field.

Now consider an arbitrarily shaped wire segment of uniform cross section in a magnetic field as shown in Figure 29.19 (page 884). It follows from Equation 29.10 that the magnetic force exerted on a small segment of vector length $d\vec{s}$ in the presence of a field \vec{B} is

$$d\vec{F}_B = I d\vec{s} \times \vec{B} \tag{29.11}$$

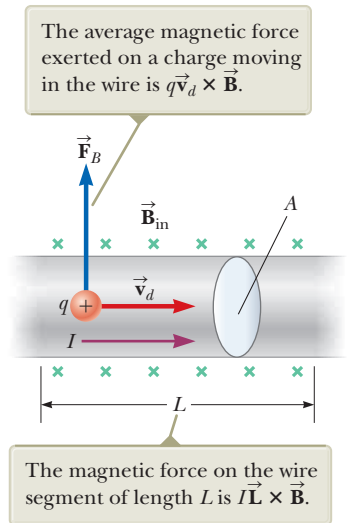
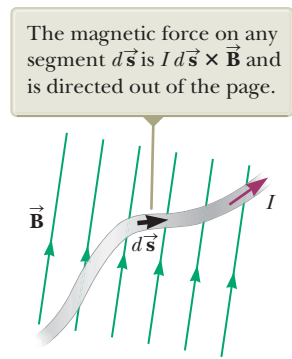

Figure 29.18 A segment of a current-carrying wire in a magnetic field \vec{B} .

◀ Force on a segment of current-carrying wire in a uniform magnetic field

Figure 29.19 A wire segment of arbitrary shape carrying a current I in a magnetic field $\vec{\mathbf{B}}$ experiences a magnetic force.



where $d\vec{\mathbf{F}}_B$ is directed out of the page for the directions of $\vec{\mathbf{B}}$ and $d\vec{\mathbf{s}}$ in Figure 29.19. Equation 29.11 can be considered as an alternative definition of $\vec{\mathbf{B}}$. That is, we can define the magnetic field $\vec{\mathbf{B}}$ in terms of a measurable force exerted on a current element, where the force is a maximum when $\vec{\mathbf{B}}$ is perpendicular to the element and zero when $\vec{\mathbf{B}}$ is parallel to the element.

To calculate the total force $\vec{\mathbf{F}}_B$ acting on the wire shown in Figure 29.19, we integrate Equation 29.11 over the length of the wire:

$$\vec{\mathbf{F}}_B = I \int_a^b d\vec{\mathbf{s}} \times \vec{\mathbf{B}} \quad (29.12)$$

where a and b represent the endpoints of the wire. When this integration is carried out, the magnitude of the magnetic field and the direction the field makes with the vector $d\vec{\mathbf{s}}$ may differ at different points.

- Quick Quiz 29.3** A wire carries current in the plane of this paper toward the top of the page. The wire experiences a magnetic force toward the right edge of the page. Is the direction of the magnetic field causing this force (a) in the plane of the page and toward the left edge, (b) in the plane of the page and toward the bottom edge, (c) upward out of the page, or (d) downward into the page?

Example 29.4 Force on a Semicircular Conductor

A wire bent into a semicircle of radius R forms a closed circuit and carries a current I . The wire lies in the xy plane, and a uniform magnetic field is directed along the positive y axis as in Figure 29.20. Find the magnitude and direction of the magnetic force acting on the straight portion of the wire and on the curved portion.

SOLUTION

Conceptualize Using the right-hand rule for cross products, we see that the force $\vec{\mathbf{F}}_1$ on the straight portion of the wire is out of the page and the force $\vec{\mathbf{F}}_2$ on the curved portion is into the page. Is $\vec{\mathbf{F}}_2$ larger in magnitude than $\vec{\mathbf{F}}_1$ because the length of the curved portion is longer than that of the straight portion?

Categorize Because we are dealing with a current-carrying wire in a magnetic field rather than a single charged particle, we must use Equation 29.12 to find the total force on each portion of the wire.

Analyze Notice that $d\vec{\mathbf{s}}$ is perpendicular to $\vec{\mathbf{B}}$ everywhere on the straight portion of the wire. Use Equation 29.12 to find the force on this portion:

$$\vec{\mathbf{F}}_1 = I \int_a^b d\vec{\mathbf{s}} \times \vec{\mathbf{B}} = I \int_{-R}^R B dx \hat{\mathbf{k}} = 2IRB \hat{\mathbf{k}}$$

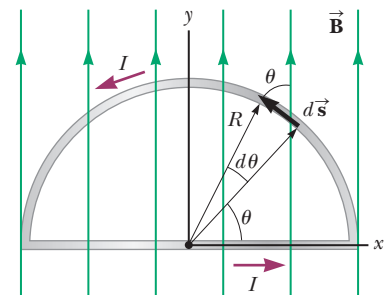

Figure 29.20 (Example 29.4) The magnetic force on the straight portion of the loop is directed out of the page, and the magnetic force on the curved portion is directed into the page.

29.4 continued

To find the magnetic force on the curved part, first write an expression for the magnetic force $d\vec{F}_2$ on the element $d\vec{s}$ in Figure 29.20:

$$(1) \quad d\vec{F}_2 = Id\vec{s} \times \vec{B} = -IB \sin \theta \, ds \hat{k}$$

From the geometry in Figure 29.20, write an expression for ds :

$$(2) \quad ds = R \, d\theta$$

Substitute Equation (2) into Equation (1) and integrate over the angle θ from 0 to π :

$$\begin{aligned} \vec{F}_2 &= -\int_0^\pi IRB \sin \theta \, d\theta \hat{k} = -IRB \int_0^\pi \sin \theta \, d\theta \hat{k} = -IRB[-\cos \theta]_0^\pi \hat{k} \\ &= IRB(\cos \pi - \cos 0)\hat{k} = IRB(-1 - 1)\hat{k} = -2IRB\hat{k} \end{aligned}$$

Finalize Two very important general statements follow from this example. First, the force on the curved portion is the same in magnitude as the force on a straight wire between the same two points. In general, the magnetic force on a curved current-carrying wire in a uniform magnetic field is equal to that on a straight wire connecting the endpoints and carrying the same current. Furthermore, $\vec{F}_1 + \vec{F}_2 = 0$ is also a general result: the net magnetic force acting on any closed current loop in a uniform magnetic field is zero.

29.5 Torque on a Current Loop in a Uniform Magnetic Field

In Section 29.4, we showed how a magnetic force is exerted on a current-carrying conductor placed in a magnetic field. With that as a starting point, we now show that a torque is exerted on a current loop placed in a magnetic field.

Consider a rectangular loop carrying a current I in the presence of a uniform magnetic field directed parallel to the plane of the loop as shown in Figure 29.21a. No magnetic forces act on sides ① and ③ because these wires are parallel to the field; hence, $\vec{L} \times \vec{B} = 0$ for these sides. Magnetic forces do, however, act on sides ② and ④ because these sides are oriented perpendicular to the field. The magnitude of these forces is, from Equation 29.10,

$$F_2 = F_4 = IaB$$

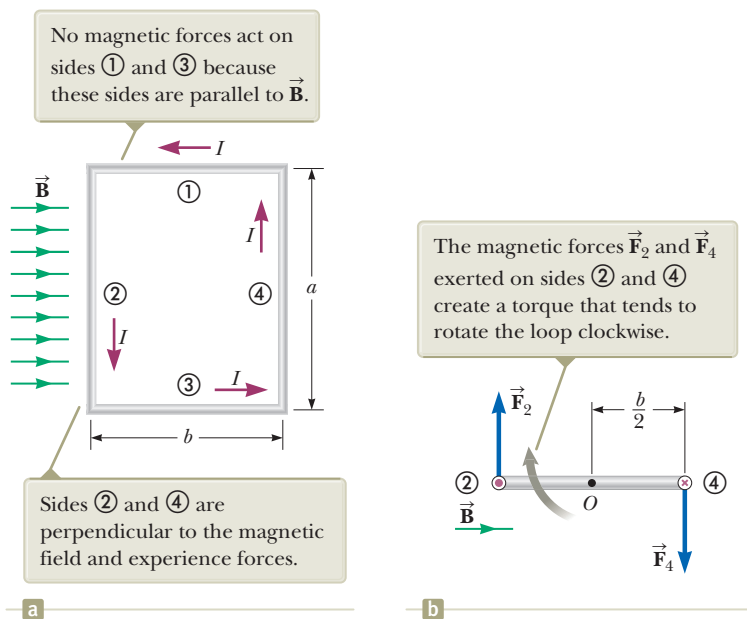

Figure 29.21 (a) Overhead view of a rectangular current loop in a uniform magnetic field. (b) Edge view of the loop sighting down sides ② and ④. The purple dot in the left circle represents current in wire ② coming toward you; the purple cross in the right circle represents current in wire ④ moving away from you.

The direction of \vec{F}_2 , the magnetic force exerted on wire ②, is out of the page in the view shown in Figure 29.20a and that of \vec{F}_4 , the magnetic force exerted on wire ④, is into the page in the same view. If we view the loop from side ③ and sight along sides ② and ④, we see the view shown in Figure 29.21b, and the two magnetic forces \vec{F}_2 and \vec{F}_4 are directed as shown. Notice that the two forces point in opposite directions but are *not* directed along the same line of action. If the loop is pivoted so that it can rotate about point O , these two forces produce about O a torque that rotates the loop clockwise. The magnitude of this torque τ_{\max} is

$$\tau_{\max} = F_2 \frac{b}{2} + F_4 \frac{b}{2} = (IaB) \frac{b}{2} + (IaB) \frac{b}{2} = IabB$$

where the moment arm about O is $b/2$ for each force. Because the area enclosed by the loop is $A = ab$, we can express the maximum torque as

$$\tau_{\max} = IAB \quad (29.13)$$

This maximum-torque result is valid only when the magnetic field is parallel to the plane of the loop. The sense of the rotation is clockwise when viewed from side ③ as indicated in Figure 29.21b. If the current direction were reversed, the force directions would also reverse and the rotational tendency would be counterclockwise.

Now suppose the uniform magnetic field makes an angle $\theta < 90^\circ$ with a line perpendicular to the plane of the loop as in Figure 29.22. For convenience, let's assume \vec{B} is perpendicular to sides ② and ④. In this case, the magnetic forces \vec{F}_1 and \vec{F}_3 exerted on sides ① and ③ cancel each other and produce no torque because they act along the same line. The magnetic forces \vec{F}_2 and \vec{F}_4 acting on sides ② and ④, however, produce a torque about *any point*. Referring to the edge view shown in Figure 29.22, we see that the moment arm of \vec{F}_2 about the point O is equal to $(b/2) \sin \theta$. Likewise, the moment arm of \vec{F}_4 about O is also equal to $(b/2) \sin \theta$. Because $F_2 = F_4 = IaB$, the magnitude of the net torque about O is

$$\begin{aligned} \tau &= F_2 \frac{b}{2} \sin \theta + F_4 \frac{b}{2} \sin \theta \\ &= IaB \left(\frac{b}{2} \sin \theta \right) + IaB \left(\frac{b}{2} \sin \theta \right) = IabB \sin \theta \\ &= IAB \sin \theta \end{aligned}$$

where $A = ab$ is the area of the loop. This result shows that the torque has its maximum value IAB when the field is perpendicular to the normal to the plane of the loop ($\theta = 90^\circ$) as discussed with regard to Figure 29.21 and is zero when the field is parallel to the normal to the plane of the loop ($\theta = 0$).

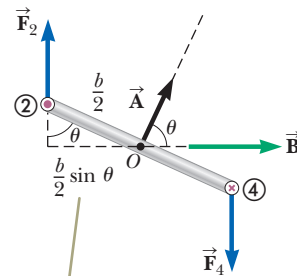

Figure 29.22 An edge view of the loop in Figure 29.21 with the normal to the loop at an angle θ with respect to the magnetic field.

When the normal to the loop makes an angle θ with the magnetic field, the moment arm for the torque is $(b/2) \sin \theta$.

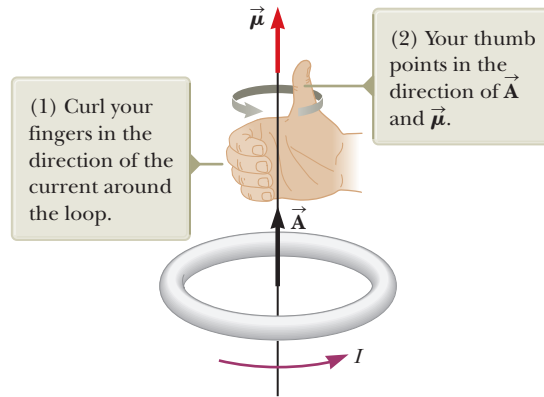

Figure 29.23 Right-hand rule for determining the direction of the vector \vec{A} for a current loop. The direction of the magnetic moment $\vec{\mu}$ is the same as the direction of \vec{A} .

A convenient vector expression for the torque exerted on a loop placed in a uniform magnetic field \vec{B} is

$$\vec{\tau} = I \vec{A} \times \vec{B} \quad (29.14)$$

where \vec{A} , the vector shown in Figure 29.22, is perpendicular to the plane of the loop and has a magnitude equal to the area of the loop. To determine the direction of \vec{A} , use the right-hand rule described in Figure 29.23. When you curl the fingers of your right hand in the direction of the current in the loop, your thumb points in the direction of \vec{A} . Figure 29.22 shows that the loop tends to rotate in the direction of decreasing values of θ (that is, such that the area vector \vec{A} rotates toward the direction of the magnetic field).

The product $I\vec{A}$ is defined to be the **magnetic dipole moment** $\vec{\mu}$ (often simply called the “magnetic moment”) of the loop:

$$\vec{\mu} \equiv I \vec{A} \quad (29.15)$$

The SI unit of magnetic dipole moment is the ampere-meter² ($A \cdot m^2$). If a coil of wire contains N loops of the same area, the magnetic moment of the coil is

$$\vec{\mu}_{\text{coil}} = NI \vec{A} \quad (29.16)$$

Using Equation 29.15, we can express the torque exerted on a current-carrying loop in a magnetic field \vec{B} as

$$\vec{\tau} = \vec{\mu} \times \vec{B} \quad (29.17)$$

This result is analogous to Equation 26.18, $\vec{\tau} = \vec{p} \times \vec{E}$, for the torque exerted on an electric dipole in the presence of an electric field \vec{E} , where \vec{p} is the electric dipole moment.

Although we obtained the torque for a particular orientation of \vec{B} with respect to the loop, the equation $\vec{\tau} = \vec{\mu} \times \vec{B}$ is valid for any orientation. Furthermore, although we derived the torque expression for a rectangular loop, the result is valid for a loop of any shape. The torque on an N -turn coil is given by Equation 29.17 by using Equation 29.16 for the magnetic moment.

In Section 26.6, we found that the potential energy of a system of an electric dipole in an electric field is given by $U_E = -\vec{p} \cdot \vec{E}$. This energy depends on the orientation of the dipole in the electric field. Likewise, the potential energy of a system of a magnetic dipole in a magnetic field depends on the orientation of the dipole in the magnetic field and is given by

$$U_B = -\vec{\mu} \cdot \vec{B} \quad (29.18)$$

◀ Torque on a current loop in a magnetic field

◀ Magnetic dipole moment of a current loop

◀ Torque on a magnetic moment in a magnetic field

◀ Potential energy of a system of a magnetic moment in a magnetic field

This expression shows that the system has its lowest energy $U_{\min} = -\mu B$ when $\vec{\mu}$ points in the same direction as \vec{B} . The system has its highest energy $U_{\max} = +\mu B$ when $\vec{\mu}$ points in the direction opposite \vec{B} .

Imagine the loop in Figure 29.22 is pivoted at point O on sides ① and ③, so that it is free to rotate. If the loop carries current and the magnetic field is turned on, the loop is modeled as a rigid object under a net torque, with the torque given by Equation 29.17. The torque on the current loop causes the loop to rotate; this effect is exploited practically in a **motor**. Energy enters the motor by electrical transmission, and the rotating coil can do work on some device external to the motor. For example, the motor in a car's electrical window system does work on the windows, applying a force on them and moving them up or down through some displacement. We will discuss motors in more detail in Section 31.5.

- Quick Quiz 29.4** (i) Rank the magnitudes of the torques acting on the rectangular loops (a), (b), and (c) shown edge-on in Figure 29.24 from highest to lowest. All loops are identical and carry the same current. (ii) Rank the magnitudes of the net forces acting on the rectangular loops shown in Figure 29.24 from highest to lowest.

Figure 29.24 (Quick Quiz 29.4) Which current loop (seen edge-on) experiences the greatest torque, (a), (b), or (c)? Which experiences the greatest net force?

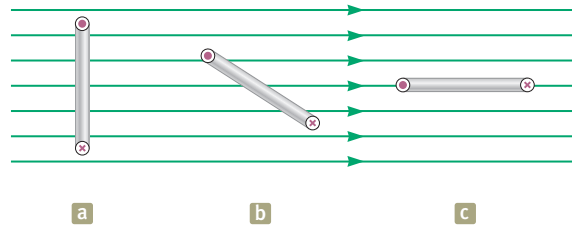

Example 29.5 The Magnetic Dipole Moment of a Coil

A rectangular coil of dimensions $5.40 \text{ cm} \times 8.50 \text{ cm}$ consists of 25 turns of wire and carries a current of 15.0 mA. A 0.350-T magnetic field is applied parallel to the plane of the coil.

(A) Calculate the magnitude of the magnetic dipole moment of the coil.

SOLUTION

Conceptualize The magnetic moment of the coil is independent of any magnetic field in which the loop resides, so it depends only on the geometry of the loop and the current it carries.

Categorize We evaluate quantities based on equations developed in this section, so we categorize this example as a substitution problem.

Use Equation 29.16 to calculate the magnetic moment associated with a coil consisting of N turns:

$$\begin{aligned}\mu_{\text{coil}} &= NIA = (25)(15.0 \times 10^{-3} \text{ A})(0.0540 \text{ m})(0.0850 \text{ m}) \\ &= 1.72 \times 10^{-3} \text{ A} \cdot \text{m}^2\end{aligned}$$

(B) What is the magnitude of the torque acting on the loop?

SOLUTION

Use Equation 29.17, noting that \vec{B} is perpendicular to $\vec{\mu}_{\text{coil}}$:

$$\begin{aligned}\tau &= \mu_{\text{coil}} B = (1.72 \times 10^{-3} \text{ A} \cdot \text{m}^2)(0.350 \text{ T}) \\ &= 6.02 \times 10^{-4} \text{ N} \cdot \text{m}\end{aligned}$$

Example 29.6 Rotating a Coil

Consider the loop of wire in Figure 29.25a. Imagine it is pivoted along side bc , which is parallel to the y axis and fastened so that side bc remains fixed and the rest of the loop hangs vertically in the gravitational field of the Earth but can rotate around side bc (Fig. 29.25b). The mass of the loop is 50.0 g , and the sides are of lengths $a = 0.200\text{ m}$ and $b = 0.100\text{ m}$. The loop carries a current of 3.50 A and is immersed in a vertical uniform magnetic field of magnitude 0.0100 T in the positive y direction (Fig. 29.25c). What angle does the plane of the loop make with the vertical?

SOLUTION

Conceptualize In the edge view of Figure 29.25b, notice that the magnetic moment of the loop is to the left. Therefore, when the loop is in the magnetic field, the magnetic torque on the loop causes it to rotate in a clockwise direction around side bc which we choose as the rotation axis. Imagine the loop making this clockwise rotation so that the plane of the loop is at some angle θ to the vertical as in Figure 29.25c. The gravitational force on the loop exerts a torque that would cause a rotation in the counter-clockwise direction if the magnetic field were turned off.

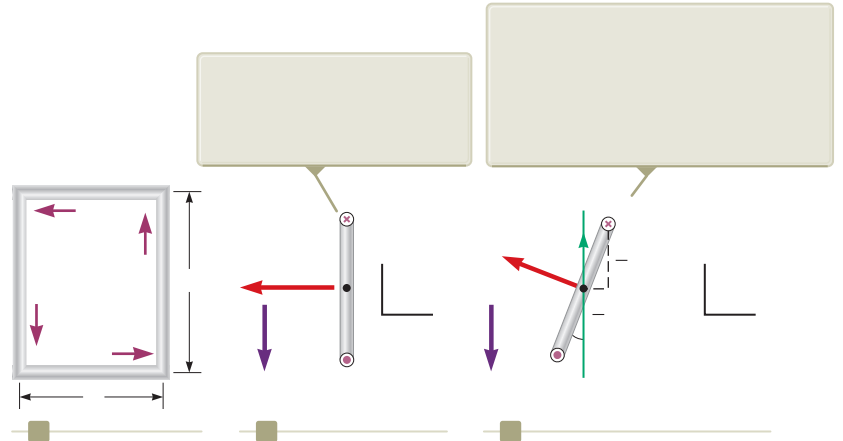

Figure 29.25 (Example 29.6) (a) The dimensions of a rectangular current loop. (b) Edge view of the loop sighting down sides ab and cd . (c) An edge view of the loop in (b) rotated through an angle with respect to the horizontal when it is placed in a magnetic field.

Categorize At some angle of the loop, the two torques described in the Conceptualize step are equal in magnitude and the loop is at rest. We therefore model the loop as a *rigid object in equilibrium*.

Analyze Evaluate the magnetic torque on the loop about side bc from Equation 29.17:

$$\tau = -\mu \sin(90^\circ - \theta) = -IAB \cos \theta \mathbf{k} = -IabB \cos \theta \mathbf{k}$$

Evaluate the gravitational torque on the loop, noting that the gravitational force can be modeled to act at the center of the loop:

$$\tau = mg \frac{a}{2} \sin \theta \mathbf{k}$$

From the rigid body in equilibrium model, add the torques and set the net torque equal to zero:

$$IabB \cos \theta = mg \frac{a}{2} \sin \theta$$

Solve for

$$\tan \theta = \frac{IaB}{mg}$$

$$\theta = \tan^{-1} \left(\frac{IaB}{mg} \right)$$

Substitute numerical values:

$$\theta = \tan^{-1} \left(\frac{(3.50\text{ A})(0.200\text{ m})(0.0100\text{ T})}{(0.0500\text{ kg})(9.80\text{ m/s}^2)} \right) = 1.64^\circ$$

Finalize The angle is relatively small, so the loop still hangs almost vertically. If the current or the magnetic field is increased, however, the angle increases as the magnetic torque becomes stronger.

29.6 The Hall Effect

When I is in the x direction and \vec{B} in the y direction, both positive and negative charge carriers are deflected upward in the magnetic field.

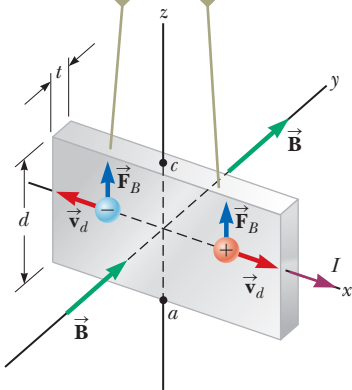

Figure 29.26 To observe the Hall effect, a magnetic field is applied to a current-carrying conductor. The Hall voltage is measured between points a and c .

When a current-carrying conductor is placed in a magnetic field, a potential difference is generated in a direction perpendicular to both the current and the magnetic field. This phenomenon, first observed by Edwin Hall (1855–1938) in 1879, is known as the *Hall effect*. The arrangement for observing the Hall effect consists of a flat conductor carrying a current I in the x direction as shown in Figure 29.26. A uniform magnetic field \vec{B} is applied in the y direction. If the charge carriers are electrons moving in the negative x direction with a drift velocity \vec{v}_d , they experience an upward magnetic force $\vec{F}_B = q\vec{v}_d \times \vec{B}$, are deflected upward, and accumulate at the upper edge of the flat conductor, leaving an excess of positive charge at the lower edge (Fig. 29.27a). This accumulation of charge at the edges establishes an electric field in the conductor and increases until the electric force on carriers remaining in the bulk of the conductor balances the magnetic force acting on the carriers. The electrons can now be described by the particle in equilibrium model, and they are no longer deflected upward. A sensitive voltmeter connected across the sample as shown in Figure 29.27 can measure the potential difference, known as the **Hall voltage** ΔV_H , generated across the conductor.

If the charge carriers are positive and hence move in the positive x direction (for rightward current) as shown in Figures 29.26 and 29.27b, they also experience an upward magnetic force $q\vec{v}_d \times \vec{B}$, which produces a buildup of positive charge on the upper edge and leaves an excess of negative charge on the lower edge. Hence, the sign of the Hall voltage generated in the sample is opposite the sign of the Hall voltage resulting from the deflection of electrons. The sign of the charge carriers can therefore be determined from measuring the polarity of the Hall voltage.

In deriving an expression for the Hall voltage, first note that the magnetic force exerted on the carriers has magnitude $qv_d B$. In equilibrium, this force is balanced by the electric force qE_H , where E_H is the magnitude of the electric field due to the charge separation (sometimes referred to as the *Hall field*). Therefore,

$$qv_d B = qE_H$$

$$E_H = v_d B$$

If d is the width of the conductor, the Hall voltage is

$$\Delta V_H = E_H d = v_d B d \quad (29.19)$$

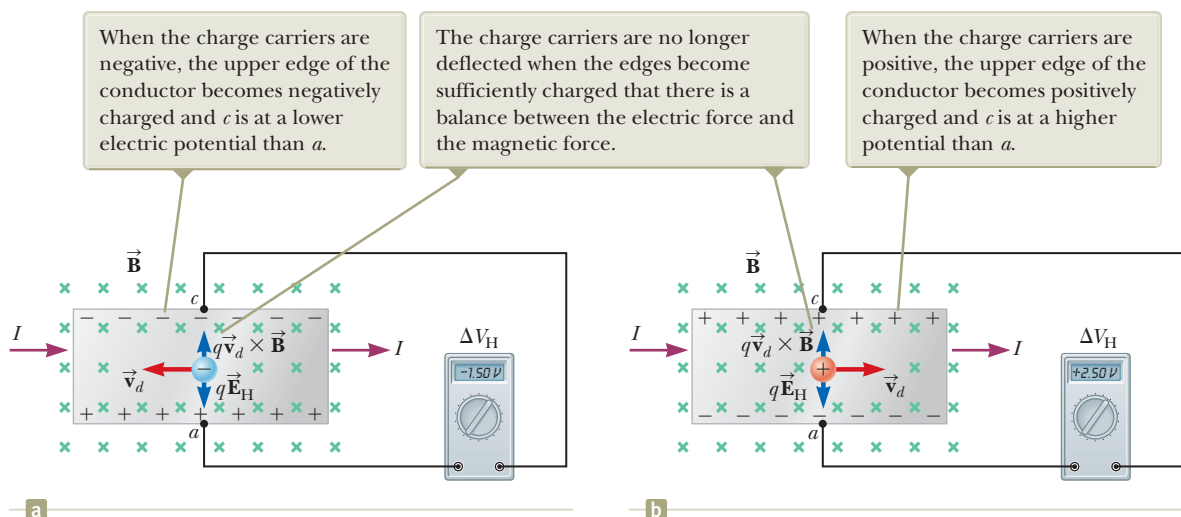

Figure 29.27 The sign of the Hall voltage depends on the sign of the charge carriers.

Therefore, the measured Hall voltage gives a value for the drift speed of the charge carriers if d and B are known.

We can obtain the charge-carrier density n by measuring the current in the sample. From Equation 27.4, we can express the drift speed as

$$v_d = \frac{I}{nqA} \quad (29.20)$$

where A is the cross-sectional area of the conductor. Substituting Equation 29.20 into Equation 29.19 gives

$$\Delta V_H = \frac{IBd}{nqA} \quad (29.21)$$

Because $A = td$, where t is the thickness of the conductor, we can also express Equation 29.21 as

$$\Delta V_H = \frac{IB}{nqt} = \frac{R_H IB}{t} \quad (29.22) \quad \leftarrow \text{The Hall voltage}$$

where $R_H = 1/nq$ is called the **Hall coefficient**. This relationship shows that a properly calibrated conductor can be used to measure the magnitude of an unknown magnetic field.

Because all quantities in Equation 29.22 other than nq can be measured, a value for the Hall coefficient is readily obtainable. The sign and magnitude of R_H give the sign of the charge carriers and their number density. In most metals, the charge carriers are electrons and the charge-carrier density determined from Hall-effect measurements is in good agreement with calculated values for such metals as lithium (Li), sodium (Na), copper (Cu), and silver (Ag), whose atoms each give up one electron to act as a current carrier. In this case, n is approximately equal to the number of conducting electrons per unit volume. This classical model, however, is not valid for metals such as iron (Fe), bismuth (Bi), and cadmium (Cd) or for semiconductors. These discrepancies can be explained only by using a model based on the quantum nature of solids.

Example 29.7 The Hall Effect for Copper

A rectangular copper strip 1.5 cm wide and 0.10 cm thick carries a current of 5.0 A. Find the Hall voltage for a 1.2-T magnetic field applied in a direction perpendicular to the strip.

SOLUTION

Conceptualize Study Figures 29.26 and 29.27 carefully and make sure you understand that a Hall voltage is developed between the top and bottom edges of the strip.

Categorize We evaluate the Hall voltage using an equation developed in this section, so we categorize this example as a substitution problem.

Assuming one electron per atom is available for conduction, find the charge-carrier density in terms of the molar mass M and density ρ of copper:

$$n = \frac{N_A}{V} = \frac{N_A \rho}{M}$$

Substitute this result into Equation 29.22:

$$\Delta V_H = \frac{IB}{nqt} = \frac{MIB}{N_A \rho qt}$$

Substitute numerical values:

$$\begin{aligned} \Delta V_H &= \frac{(0.0635 \text{ kg/mol})(5.0 \text{ A})(1.2 \text{ T})}{(6.02 \times 10^{23} \text{ mol}^{-1})(8920 \text{ kg/m}^3)(1.60 \times 10^{-19} \text{ C})(0.0010 \text{ m})} \\ &= 0.44 \mu\text{V} \end{aligned} \quad \text{continued}$$

▶ 29.7 continued

Such an extremely small Hall voltage is expected in good conductors. (Notice that the width of the conductor is not needed in this calculation.)

WHAT IF? What if the strip has the same dimensions but is made of a semiconductor? Will the Hall voltage be smaller or larger?

Answer In semiconductors, n is much smaller than it is in metals that contribute one electron per atom to the current; hence, the Hall voltage is usually larger because it varies as the inverse of n . Currents on the order of 0.1 mA are generally used for such materials. Consider a piece of silicon that has the same dimensions as the copper strip in this example and whose value for n is 1.0×10^{20} electrons/m³. Taking $B = 1.2$ T and $I = 0.10$ mA, we find that $\Delta V_H = 7.5$ mV. A potential difference of this magnitude is readily measured.

Summary

Definition

■ The **magnetic dipole moment** $\vec{\mu}$ of a loop carrying a current I is

$$\vec{\mu} \equiv I\vec{A} \quad (29.15)$$

where the area vector \vec{A} is perpendicular to the plane of the loop and $|\vec{A}|$ is equal to the area of the loop. The SI unit of $\vec{\mu}$ is $\text{A} \cdot \text{m}^2$.

Concepts and Principles

■ If a charged particle moves in a uniform magnetic field so that its initial velocity is perpendicular to the field, the particle moves in a circle, the plane of which is perpendicular to the magnetic field. The radius of the circular path is

$$r = \frac{mv}{qB} \quad (29.3)$$

where m is the mass of the particle and q is its charge. The angular speed of the charged particle is

$$\omega = \frac{qB}{m} \quad (29.4)$$

■ If a straight conductor of length L carries a current I , the force exerted on that conductor when it is placed in a uniform magnetic field \vec{B} is

$$\vec{F}_B = I\vec{L} \times \vec{B} \quad (29.10)$$

where the direction of \vec{L} is in the direction of the current and $|\vec{L}| = L$.

■ If an arbitrarily shaped wire carrying a current I is placed in a magnetic field, the magnetic force exerted on a very small segment $d\vec{s}$ is

$$d\vec{F}_B = I d\vec{s} \times \vec{B} \quad (29.11)$$

To determine the total magnetic force on the wire, one must integrate Equation 29.11 over the wire, keeping in mind that both \vec{B} and $d\vec{s}$ may vary at each point.

■ The torque $\vec{\tau}$ on a current loop placed in a uniform magnetic field \vec{B} is

$$\vec{\tau} = \vec{\mu} \times \vec{B} \quad (29.17)$$

■ The potential energy of the system of a magnetic dipole in a magnetic field is

$$U_B = -\vec{\mu} \cdot \vec{B} \quad (29.18)$$

Analysis Models for Problem Solving

Particle in a Field (Magnetic) A source (to be discussed in Chapter 30) establishes a magnetic field $\vec{\mathbf{B}}$ throughout space. When a particle with charge q and moving with velocity $\vec{\mathbf{v}}$ is placed in that field, it experiences a magnetic force given by

$$\vec{\mathbf{F}}_B = q\vec{\mathbf{v}} \times \vec{\mathbf{B}} \quad (29.1)$$

The direction of this magnetic force is perpendicular both to the velocity of the particle and to the magnetic field. The magnitude of this force is

$$F_B = |q|vB \sin \theta \quad (29.2)$$

where θ is the smaller angle between $\vec{\mathbf{v}}$ and $\vec{\mathbf{B}}$. The SI unit of $\vec{\mathbf{B}}$ is the **tesla** (T), where $1 \text{ T} = 1 \text{ N/A} \cdot \text{m}$.

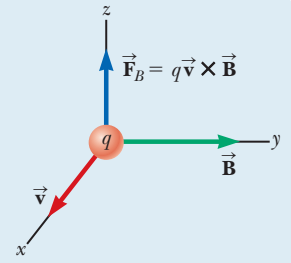

Objective Questions

1. denotes answer available in *Student Solutions Manual/Study Guide*

Objective Questions 3, 4, and 6 in Chapter 11 can be assigned with this chapter as review for the vector product.

- A spatially uniform magnetic field cannot exert a magnetic force on a particle in which of the following circumstances? There may be more than one correct statement. (a) The particle is charged. (b) The particle moves perpendicular to the magnetic field. (c) The particle moves parallel to the magnetic field. (d) The magnitude of the magnetic field changes with time. (e) The particle is at rest.
- Rank the magnitudes of the forces exerted on the following particles from largest to smallest. In your ranking, display any cases of equality. (a) an electron moving at 1 Mm/s perpendicular to a 1-mT magnetic field (b) an electron moving at 1 Mm/s parallel to a 1-mT magnetic field (c) an electron moving at 2 Mm/s perpendicular to a 1-mT magnetic field (d) a proton moving at 1 Mm/s perpendicular to a 1-mT magnetic field (e) a proton moving at 1 Mm/s at a 45° angle to a 1-mT magnetic field
- A particle with electric charge is fired into a region of space where the electric field is zero. It moves in a straight line. Can you conclude that the magnetic field in that region is zero? (a) Yes, you can. (b) No; the field might be perpendicular to the particle's velocity. (c) No; the field might be parallel to the particle's velocity. (d) No; the particle might need to have charge of the opposite sign to have a force exerted on it. (e) No; an observation of an object with *electric* charge gives no information about a *magnetic* field.
- A proton moving horizontally enters a region where a uniform magnetic field is directed perpendicular to the proton's velocity as shown in Figure OQ29.4. After the proton enters the field, does it (a) deflect downward, with its speed remaining constant; (b) deflect upward, moving in a semicircular path with constant speed, and exit the field moving to the left; (c) continue to move in the horizontal direction with constant velocity; (d) move in a circular orbit and become trapped by the field; or (e) deflect out of the plane of the paper?



Figure OQ29.4

- At a certain instant, a proton is moving in the positive x direction through a magnetic field in the negative z direction. What is the direction of the magnetic force exerted on the proton? (a) positive z direction (b) negative z direction (c) positive y direction (d) negative y direction (e) The force is zero.
- A thin copper rod 1.00 m long has a mass of 50.0 g. What is the minimum current in the rod that would allow it to levitate above the ground in a magnetic field of magnitude 0.100 T? (a) 1.20 A (b) 2.40 A (c) 4.90 A (d) 9.80 A (e) none of those answers
- Electron A is fired horizontally with speed 1.00 Mm/s into a region where a vertical magnetic field exists. Electron B is fired along the same path with speed 2.00 Mm/s. (i) Which electron has a larger magnetic force exerted on it? (a) A does. (b) B does. (c) The forces have the same nonzero magnitude. (d) The forces are both zero. (ii) Which electron has a path that curves more sharply? (a) A does. (b) B does. (c) The particles follow the same curved path. (d) The particles continue to go straight.
- Classify each of the following statements as a characteristic (a) of electric forces only, (b) of magnetic forces only, (c) of both electric and magnetic forces, or (d) of neither electric nor magnetic forces. (i) The force is proportional to the magnitude of the field exerting it. (ii) The force is proportional to the magnitude of the charge of the object on which the force is exerted. (iii) The force exerted on a negatively charged object is opposite in direction to the force on a positive charge. (iv) The force exerted on a stationary charged object is nonzero. (v) The force exerted on a moving charged

- object is zero. (vi) The force exerted on a charged object is proportional to its speed. (vii) The force exerted on a charged object cannot alter the object's speed. (viii) The magnitude of the force depends on the charged object's direction of motion.
9. An electron moves horizontally across the Earth's equator at a speed of 2.50×10^6 m/s and in a direction 35.0° N of E. At this point, the Earth's magnetic field has a direction due north, is parallel to the surface, and has a value of 3.00×10^{-5} T. What is the force acting on the electron due to its interaction with the Earth's magnetic field? (a) 6.88×10^{-18} N due west (b) 6.88×10^{-18} N toward the Earth's surface (c) 9.83×10^{-18} N toward the Earth's surface (d) 9.83×10^{-18} N away from the Earth's surface (e) 4.00×10^{-18} N away from the Earth's surface
10. A charged particle is traveling through a uniform magnetic field. Which of the following statements are true of the magnetic field? There may be more than one correct statement. (a) It exerts a force on the particle parallel to the field. (b) It exerts a force on the particle along the direction of its motion. (c) It increases the kinetic energy of the particle. (d) It exerts a force that is perpendicular to the direction of motion. (e) It does not change the magnitude of the momentum of the particle.
11. In the velocity selector shown in Figure 29.13, electrons with speed $v = E/B$ follow a straight path. Electrons moving significantly faster than this speed through the same selector will move along what kind of path? (a) a circle (b) a parabola (c) a straight line (d) a more complicated trajectory
12. Answer each question yes or no. Assume the motions and currents mentioned are along the x axis and fields are in the y direction. (a) Does an electric field exert a force on a stationary charged object? (b) Does a magnetic field do so? (c) Does an electric field exert a force on a moving charged object? (d) Does a magnetic field do so? (e) Does an electric field exert a force on a straight current-carrying wire? (f) Does a magnetic field do so? (g) Does an electric field exert a force on a beam of moving electrons? (h) Does a magnetic field do so?
13. A magnetic field exerts a torque on each of the current-carrying single loops of wire shown in Figure OQ29.13. The loops lie in the xy plane, each carrying the same magnitude current, and the uniform magnetic field points in the positive x direction. Rank the loops by the magnitude of the torque exerted on them by the field from largest to smallest.

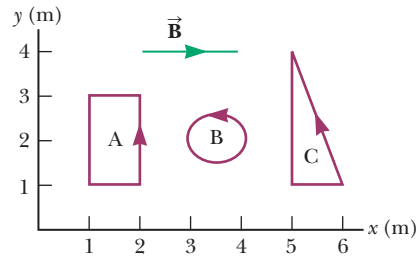

Figure OQ29.13

Conceptual Questions

1. denotes answer available in *Student Solutions Manual/Study Guide*

- Can a constant magnetic field set into motion an electron initially at rest? Explain your answer.
- Explain why it is not possible to determine the charge and the mass of a charged particle separately by measuring accelerations produced by electric and magnetic forces on the particle.
- Is it possible to orient a current loop in a uniform magnetic field such that the loop does not tend to rotate? Explain.
- How can the motion of a moving charged particle be used to distinguish between a magnetic field and an electric field? Give a specific example to justify your argument.
- How can a current loop be used to determine the presence of a magnetic field in a given region of space?
- Charged particles from outer space, called cosmic rays, strike the Earth more frequently near the poles than near the equator. Why?
- Two charged particles are projected in the same direction into a magnetic field perpendicular to their velocities. If the particles are deflected in opposite directions, what can you say about them?

Problems



The problems found in this chapter may be assigned online in Enhanced WebAssign

1. straightforward; 2. intermediate; 3. challenging

1. full solution available in the *Student Solutions Manual/Study Guide*



Analysis Model tutorial available in Enhanced WebAssign



Guided Problem



Master It tutorial available in Enhanced WebAssign



Watch It video solution available in Enhanced WebAssign

Section 29.1 Analysis Model: Particle in a Field (Magnetic)

Problems 1–4, 6–7, and 10 in Chapter 11 can be assigned with this section as review for the vector product.

1. At the equator, near the surface of the Earth, the magnetic field is approximately $50.0 \mu\text{T}$ northward, and the electric field is about 100 N/C downward in fair weather. Find the gravitational, electric, and magnetic forces on an electron in this environment, assuming that the electron has an instantaneous velocity of $6.00 \times 10^6 \text{ m/s}$ directed to the east.

2. Determine the initial direction of the deflection of charged particles as they enter the magnetic fields shown in Figure P29.2.

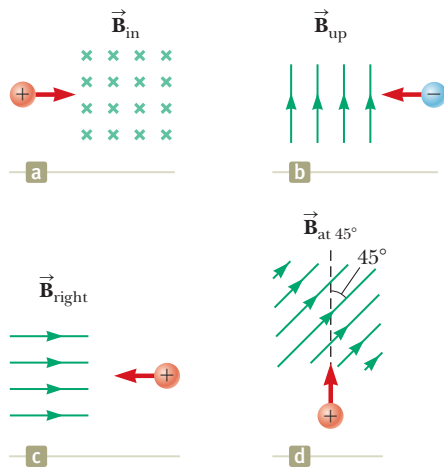

Figure P29.2

3. Find the direction of the magnetic field acting on a positively charged particle moving in the various situations shown in Figure P29.3 if the direction of the magnetic force acting on it is as indicated.

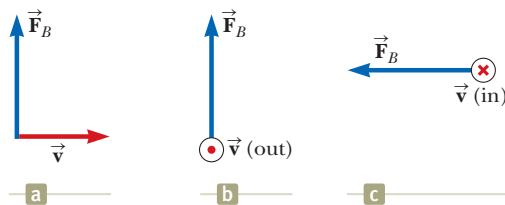

Figure P29.3

4. Consider an electron near the Earth's equator. In which direction does it tend to deflect if its velocity is (a) directed downward? (b) Directed northward? (c) Directed westward? (d) Directed southeastward?
5. A proton is projected into a magnetic field that is directed along the positive x axis. Find the direction of the magnetic force exerted on the proton for each of the following directions of the proton's velocity: (a) the positive y direction, (b) the negative y direction, (c) the positive x direction.

6. A proton moving at $4.00 \times 10^6 \text{ m/s}$ through a magnetic field of magnitude 1.70 T experiences a magnetic force of magnitude $8.20 \times 10^{-13} \text{ N}$. What is the angle between the proton's velocity and the field?

7. An electron is accelerated through $2.40 \times 10^3 \text{ V}$ from rest and then enters a uniform 1.70-T magnetic field. What are (a) the maximum and (b) the minimum values of the magnetic force this particle experiences?

8. A proton moves with a velocity of $\vec{v} = (2\hat{i} - 4\hat{j} + \hat{k}) \text{ m/s}$ in a region in which the magnetic field is $\vec{B} = (\hat{i} + 2\hat{j} - \hat{k}) \text{ T}$. What is the magnitude of the magnetic force this particle experiences?

9. A proton travels with a speed of $5.02 \times 10^6 \text{ m/s}$ in a direction that makes an angle of 60.0° with the direction of a magnetic field of magnitude 0.180 T in the positive x direction. What are the magnitudes of (a) the magnetic force on the proton and (b) the proton's acceleration?

10. A laboratory electromagnet produces a magnetic field of magnitude 1.50 T . A proton moves through this field with a speed of $6.00 \times 10^6 \text{ m/s}$. (a) Find the magnitude of the maximum magnetic force that could be exerted on the proton. (b) What is the magnitude of the maximum acceleration of the proton? (c) Would the field exert the same magnetic force on an electron moving through the field with the same speed? (d) Would the electron experience the same acceleration? Explain.

11. A proton moves perpendicular to a uniform magnetic field \vec{B} at a speed of $1.00 \times 10^7 \text{ m/s}$ and experiences an acceleration of $2.00 \times 10^{13} \text{ m/s}^2$ in the positive x direction when its velocity is in the positive z direction. Determine the magnitude and direction of the field.

12. **Review.** A charged particle of mass 1.50 g is moving at a speed of $1.50 \times 10^4 \text{ m/s}$. Suddenly, a uniform magnetic field of magnitude 0.150 mT in a direction perpendicular to the particle's velocity is turned on and then turned off in a time interval of 1.00 s . During this time interval, the magnitude and direction of the velocity of the particle undergo a negligible change, but the particle moves by a distance of 0.150 m in a direction perpendicular to the velocity. Find the charge on the particle.

Section 29.2 Motion of a Charged Particle in a Uniform Magnetic Field

13. An electron moves in a circular path perpendicular to a uniform magnetic field with a magnitude of 2.00 mT . If the speed of the electron is $1.50 \times 10^7 \text{ m/s}$, determine (a) the radius of the circular path and (b) the time interval required to complete one revolution.
14. An accelerating voltage of $2.50 \times 10^3 \text{ V}$ is applied to an electron gun, producing a beam of electrons originally traveling horizontally north in vacuum toward the center of a viewing screen 35.0 cm away. What are (a) the magnitude and (b) the direction of the deflection on

the screen caused by the Earth's gravitational field? What are (c) the magnitude and (d) the direction of the deflection on the screen caused by the vertical component of the Earth's magnetic field, taken as $20.0 \mu\text{T}$ down? (e) Does an electron in this vertical magnetic field move as a projectile, with constant vector acceleration perpendicular to a constant northward component of velocity? (f) Is it a good approximation to assume it has this projectile motion? Explain.

15. A proton (charge $+e$, mass m_p), a deuteron (charge $+e$, mass $2m_p$), and an alpha particle (charge $+2e$, mass $4m_p$) are accelerated from rest through a common potential difference ΔV . Each of the particles enters a uniform magnetic field \vec{B} , with its velocity in a direction perpendicular to \vec{B} . The proton moves in a circular path of radius r_p . In terms of r_p , determine (a) the radius r_d of the circular orbit for the deuteron and (b) the radius r_α for the alpha particle.

16. A particle with charge q and kinetic energy K travels in a uniform magnetic field of magnitude B . If the particle moves in a circular path of radius R , find expressions for (a) its speed and (b) its mass.

17. Review. One electron collides elastically with a second electron initially at rest. After the collision, the radii of their trajectories are 1.00 cm and 2.40 cm . The trajectories are perpendicular to a uniform magnetic field of magnitude 0.0440 T . Determine the energy (in keV) of the incident electron.

18. Review. One electron collides elastically with a second electron initially at rest. After the collision, the radii of their trajectories are r_1 and r_2 . The trajectories are perpendicular to a uniform magnetic field of magnitude B . Determine the energy of the incident electron.

19. Review. An electron moves in a circular path perpendicular to a constant magnetic field of magnitude 1.00 mT . The angular momentum of the electron about the center of the circle is $4.00 \times 10^{-25} \text{ kg} \cdot \text{m}^2/\text{s}$. Determine (a) the radius of the circular path and (b) the speed of the electron.

20. Review. A 30.0-g metal ball having net charge $Q = 5.00 \mu\text{C}$ is thrown out of a window horizontally north at a speed $v = 20.0 \text{ m/s}$. The window is at a height $h = 20.0 \text{ m}$ above the ground. A uniform, horizontal magnetic field of magnitude $B = 0.0100 \text{ T}$ is perpendicular to the plane of the ball's trajectory and directed toward the west. (a) Assuming the ball follows the same trajectory as it would in the absence of the magnetic field, find the magnetic force acting on the ball just before it hits the ground. (b) Based on the result of part (a), is it justified for three-significant-digit precision to assume the trajectory is unaffected by the magnetic field? Explain.

21. A cosmic-ray proton in interstellar space has an energy of 10.0 MeV and executes a circular orbit having a radius equal to that of Mercury's orbit around the Sun ($5.80 \times 10^{10} \text{ m}$). What is the magnetic field in that region of space?

22. Assume the region to the right of a certain plane contains a uniform magnetic field of magnitude 1.00 mT and the field is zero in the region to the left of the plane as shown in Figure P29.22. An electron, originally traveling perpendicular to the boundary plane, passes into the region of the field. (a) Determine the time interval required for the electron to leave the "field-filled" region, noting that the electron's path is a semicircle. (b) Assuming the maximum depth of penetration into the field is 2.00 cm , find the kinetic energy of the electron.

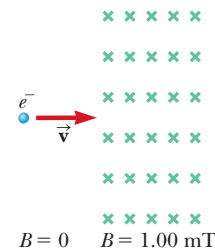

Figure P29.22

23. A singly charged ion of mass m is accelerated from rest by a potential difference ΔV . It is then deflected by a uniform magnetic field (perpendicular to the ion's velocity) into a semicircle of radius R . Now a doubly charged ion of mass m' is accelerated through the same potential difference and deflected by the same magnetic field into a semicircle of radius $R' = 2R$. What is the ratio of the masses of the ions?

Section 29.3 Applications Involving Charged Particles Moving in a Magnetic Field

24. A cyclotron designed to accelerate protons has a magnetic field of magnitude 0.450 T over a region of radius 1.20 m . What are (a) the cyclotron frequency and (b) the maximum speed acquired by the protons?

25. Consider the mass spectrometer shown schematically in Figure 29.14. The magnitude of the electric field between the plates of the velocity selector is $2.50 \times 10^3 \text{ V/m}$, and the magnetic field in both the velocity selector and the deflection chamber has a magnitude of 0.0350 T . Calculate the radius of the path for a singly charged ion having a mass $m = 2.18 \times 10^{-26} \text{ kg}$.

26. Singly charged uranium-238 ions are accelerated through a potential difference of 2.00 kV and enter a uniform magnetic field of magnitude 1.20 T directed perpendicular to their velocities. (a) Determine the radius of their circular path. (b) Repeat this calculation for uranium-235 ions. (c) **What If?** How does the ratio of these path radii depend on the accelerating voltage? (d) On the magnitude of the magnetic field?

27. A cyclotron (Fig. 29.16) designed to accelerate protons has an outer radius of 0.350 m . The protons are emitted nearly at rest from a source at the center and are accelerated through 600 V each time they cross the gap between the dees. The dees are between the poles of an electromagnet where the field is 0.800 T . (a) Find the cyclotron frequency for the protons in

this cyclotron. Find (b) the speed at which protons exit the cyclotron and (c) their maximum kinetic energy. (d) How many revolutions does a proton make in the cyclotron? (e) For what time interval does the proton accelerate?

28. A particle in the cyclotron shown in Figure 29.16a gains energy $q \Delta V$ from the alternating power supply each time it passes from one dee to the other. The time interval for each full orbit is

$$T = \frac{2\pi}{\omega} = \frac{2\pi m}{qB}$$

so the particle's average rate of increase in energy is

$$\frac{2q \Delta V}{T} = \frac{q^2 B \Delta V}{\pi m}$$

Notice that this power input is constant in time. On the other hand, the rate of increase in the radius r of its path is *not* constant. (a) Show that the rate of increase in the radius r of the particle's path is given by

$$\frac{dr}{dt} = \frac{1}{r} \frac{\Delta V}{\pi B}$$

(b) Describe how the path of the particles in Figure 29.16a is consistent with the result of part (a). (c) At what rate is the radial position of the protons in a cyclotron increasing immediately before the protons leave the cyclotron? Assume the cyclotron has an outer radius of 0.350 m, an accelerating voltage of $\Delta V = 600$ V, and a magnetic field of magnitude 0.800 T. (d) By how much does the radius of the protons' path increase during their last full revolution?

29. A velocity selector consists of electric and magnetic fields described by the expressions $\vec{E} = E\hat{k}$ and $\vec{B} = B\hat{j}$, with $B = 15.0$ mT. Find the value of E such that a 750-eV electron moving in the negative x direction is undeflected.
30. In his experiments on "cathode rays" during which he discovered the electron, J. J. Thomson showed that the same beam deflections resulted with tubes having cathodes made of *different* materials and containing *various* gases before evacuation. (a) Are these observations important? Explain your answer. (b) When he applied various potential differences to the deflection plates and turned on the magnetic coils, alone or in combination with the deflection plates, Thomson observed that the fluorescent screen continued to show a *single small* glowing patch. Argue whether his observation is important. (c) Do calculations to show that the charge-to-mass ratio Thomson obtained was huge compared with that of any macroscopic object or of any ionized atom or molecule. How can one make sense of this comparison? (d) Could Thomson observe any deflection of the beam due to gravitation? Do a calculation to argue for your answer. *Note:* To obtain a visibly glowing patch on the fluorescent screen, the potential difference between the slits and the cathode must be 100 V or more.

31. The picture tube in an old black-and-white television uses magnetic deflection coils rather than electric

deflection plates. Suppose an electron beam is accelerated through a 50.0-kV potential difference and then through a region of uniform magnetic field 1.00 cm wide. The screen is located 10.0 cm from the center of the coils and is 50.0 cm wide. When the field is turned off, the electron beam hits the center of the screen. Ignoring relativistic corrections, what field magnitude is necessary to deflect the beam to the side of the screen?

Section 29.4 Magnetic Force Acting on a Current-Carrying Conductor

32. A straight wire carrying a 3.00-A current is placed in a uniform magnetic field of magnitude 0.280 T directed perpendicular to the wire. (a) Find the magnitude of the magnetic force on a section of the wire having a length of 14.0 cm. (b) Explain why you can't determine the direction of the magnetic force from the information given in the problem.
33. A conductor carrying a current $I = 15.0$ A is directed along the positive x axis and perpendicular to a uniform magnetic field. A magnetic force per unit length of 0.120 N/m acts on the conductor in the negative y direction. Determine (a) the magnitude and (b) the direction of the magnetic field in the region through which the current passes.
34. A wire 2.80 m in length carries a current of 5.00 A in a region where a uniform magnetic field has a magnitude of 0.390 T. Calculate the magnitude of the magnetic force on the wire assuming the angle between the magnetic field and the current is (a) 60.0° , (b) 90.0° , and (c) 120° .
35. A wire carries a steady current of 2.40 A. A straight section of the wire is 0.750 m long and lies along the x axis within a uniform magnetic field, $\vec{B} = 1.60\hat{k}$ T. If the current is in the positive x direction, what is the magnetic force on the section of wire?
36. *Why is the following situation impossible?* Imagine a copper wire with radius 1.00 mm encircling the Earth at its magnetic equator, where the field direction is horizontal. A power supply delivers 100 MW to the wire to maintain a current in it, in a direction such that the magnetic force from the Earth's magnetic field is upward. Due to this force, the wire is levitated immediately above the ground.
37. **Review.** A rod of mass 0.720 kg and radius 6.00 cm rests on two parallel rails (Fig. P29.37) that are $d = 12.0$ cm apart and $L = 45.0$ cm long. The rod carries a

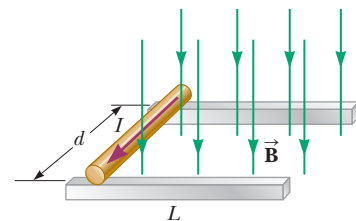

Figure P29.37 Problems 37 and 38.

current of $I = 48.0 \text{ A}$ in the direction shown and rolls along the rails without slipping. A uniform magnetic field of magnitude 0.240 T is directed perpendicular to the rod and the rails. If it starts from rest, what is the speed of the rod as it leaves the rails?

- 38. Review.** A rod of mass m and radius R rests on two parallel rails (Fig. P29.37) that are a distance d apart and have a length L . The rod carries a current I in the direction shown and rolls along the rails without slipping. A uniform magnetic field B is directed perpendicular to the rod and the rails. If it starts from rest, what is the speed of the rod as it leaves the rails?

- 39.** A wire having a mass per unit length of 0.500 g/cm carries a 2.00-A current horizontally to the south. What are (a) the direction and (b) the magnitude of the minimum magnetic field needed to lift this wire vertically upward?

- 40.** Consider the system pictured in Figure P29.40. A 15.0-cm horizontal wire of mass 15.0 g is placed between two thin, vertical conductors, and a uniform magnetic field acts perpendicular to the page. The wire is free to move vertically without friction on the two vertical conductors. When a 5.00-A current is directed as shown in the figure, the horizontal wire moves upward at constant velocity in the presence of gravity. (a) What forces act on the horizontal wire, and (b) under what condition is the wire able to move upward at constant velocity? (c) Find the magnitude and direction of the minimum magnetic field required to move the wire at constant speed. (d) What happens if the magnetic field exceeds this minimum value?

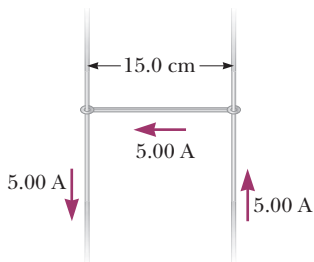

Figure P29.40

- 41.** A horizontal power line of length 58.0 m carries a current of 2.20 kA northward as shown in Figure P29.41. The Earth's magnetic field at this location has a magnitude of $5.00 \times 10^{-5} \text{ T}$. The field at this location is directed toward the north at an angle 65.0° below the

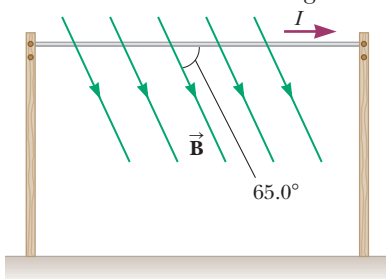

Figure P29.41

power line. Find (a) the magnitude and (b) the direction of the magnetic force on the power line.

- 42.** A strong magnet is placed under a horizontal conducting ring of radius r that carries current I as shown in Figure P29.42. If the magnetic field \vec{B} makes an angle θ with the vertical at the ring's location, what are (a) the magnitude and (b) the direction of the resultant magnetic force on the ring?

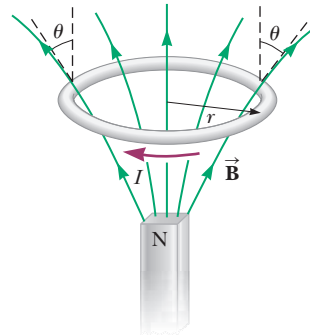

Figure P29.42

- 43.** Assume the Earth's magnetic field is $52.0 \mu\text{T}$ northward at 60.0° below the horizontal in Atlanta, Georgia. A tube in a neon sign stretches between two diagonally opposite corners of a shop window—which lies in a north-south vertical plane—and carries current 35.0 mA . The current enters the tube at the bottom south corner of the shop's window. It exits at the opposite corner, which is 1.40 m farther north and 0.850 m higher up. Between these two points, the glowing tube spells out DONUTS. Determine the total vector magnetic force on the tube. *Hint:* You may use the first "important general statement" presented in the Finalize section of Example 29.4.
- 44.** In Figure P29.44, the cube is 40.0 cm on each edge. Four straight segments of wire— ab , bc , cd , and da —form a closed loop that carries a current $I = 5.00 \text{ A}$ in the direction shown. A uniform magnetic field of magnitude $B = 0.0200 \text{ T}$ is in the positive y direction. Determine the magnetic force vector on (a) ab , (b) bc , (c) cd , and (d) da . (e) Explain how you could find the force exerted on the fourth of these segments from the forces on the other three, without further calculation involving the magnetic field.

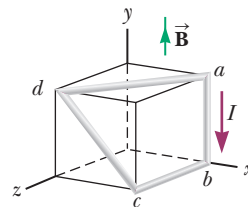

Figure P29.44

Section 29.5 Torque on a Current Loop in a Uniform Magnetic Field

- 45.** A typical magnitude of the external magnetic field in a cardiac catheter ablation procedure using remote

magnetic navigation is $B = 0.080$ T. Suppose that the permanent magnet in the catheter used in the procedure is inside the left atrium of the heart and subject to this external magnetic field. The permanent magnet has a magnetic moment of $0.10 \text{ A} \cdot \text{m}^2$. The orientation of the permanent magnet is 30° from the direction of the external magnetic field lines. (a) What is the magnitude of the torque on the tip of the catheter containing this permanent magnet? (b) What is the potential energy of the system consisting of the permanent magnet in the catheter and the magnetic field provided by the external magnets?

46. A 50.0-turn circular coil of radius 5.00 cm can be oriented in any direction in a uniform magnetic field having a magnitude of 0.500 T. If the coil carries a current of 25.0 mA, find the magnitude of the maximum possible torque exerted on the coil.
47. A magnetized sewing needle has a magnetic moment of $9.70 \text{ mA} \cdot \text{m}^2$. At its location, the Earth's magnetic field is $55.0 \mu\text{T}$ northward at 48.0° below the horizontal. Identify the orientations of the needle that represent (a) the minimum potential energy and (b) the maximum potential energy of the needle-field system. (c) How much work must be done on the system to move the needle from the minimum to the maximum potential energy orientation?
48. A current of 17.0 mA is maintained in a single circular loop of 2.00 m circumference. A magnetic field of 0.800 T is directed parallel to the plane of the loop. (a) Calculate the magnetic moment of the loop. (b) What is the magnitude of the torque exerted by the magnetic field on the loop?
49. An eight-turn coil encloses an elliptical area having a major axis of 40.0 cm and a minor axis of 30.0 cm (Fig. P29.49). The coil lies in the plane of the page and has a 6.00-A current flowing clockwise around it. If the coil is in a uniform magnetic field of 2.00×10^{-4} T directed toward the left of the page, what is the magnitude of the torque on the coil? *Hint:* The area of an ellipse is $A = \pi ab$, where a and b are, respectively, the semimajor and semiminor axes of the ellipse.

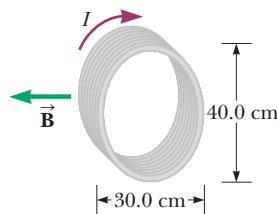

Figure P29.49

50. The rotor in a certain electric motor is a flat, rectangular coil with 80 turns of wire and dimensions 2.50 cm by 4.00 cm. The rotor rotates in a uniform magnetic field of 0.800 T. When the plane of the rotor is perpendicular to the direction of the magnetic field, the rotor carries a current of 10.0 mA. In this orientation, the magnetic moment of the rotor is directed opposite the magnetic field. The rotor then turns through one-

half revolution. This process is repeated to cause the rotor to turn steadily at an angular speed of 3.60×10^3 rev/min. (a) Find the maximum torque acting on the rotor. (b) Find the peak power output of the motor. (c) Determine the amount of work performed by the magnetic field on the rotor in every full revolution. (d) What is the average power of the motor?

51. A rectangular coil consists of $N = 100$ closely wrapped turns and has dimensions $a = 0.400$ m and $b = 0.300$ m. The coil is hinged along the y axis, and its plane makes an angle $\theta = 30.0^\circ$ with the x axis (Fig. P29.51). (a) What is the magnitude of the torque exerted on the coil by a uniform magnetic field $B = 0.800$ T directed in the positive x direction when the current is $I = 1.20$ A in the direction shown? (b) What is the expected direction of rotation of the coil?

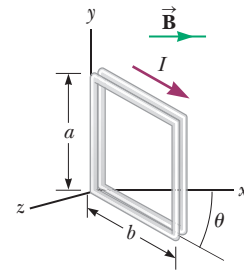

Figure P29.51

52. A rectangular loop of wire has dimensions 0.500 m by 0.300 m. The loop is pivoted at the x axis and lies in the xy plane as shown in Figure P29.52. A uniform magnetic field of magnitude 1.50 T is directed at an angle of 40.0° with respect to the y axis with field lines parallel to the yz plane. The loop carries a current of 0.900 A in the direction shown. (Ignore gravitation.) We wish to evaluate the torque on the current loop. (a) What is the direction of the magnetic force exerted on wire segment ab ? (b) What is the direction of the torque associated with this force about an axis through the origin? (c) What is the direction of the magnetic force exerted on segment cd ? (d) What is the direction of the torque associated with this force about an axis through the origin? (e) Can the forces examined in parts (a) and (c) combine to cause the loop to rotate around the x axis? (f) Can they affect the motion of the loop in any way? Explain. (g) What is the direction of the magnetic force exerted on segment bc ? (h) What is the direction of the torque associated with this force about an axis through the origin? (i) What is the torque on segment ad about an axis through the origin? (j) From the point of view of Figure P29.52, once the loop is released from rest at

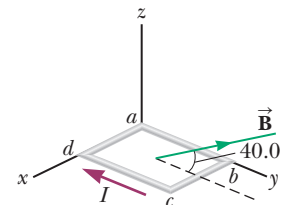

Figure P29.52

the position shown, will it rotate clockwise or counterclockwise around the x axis? (k) Compute the magnitude of the magnetic moment of the loop. (l) What is the angle between the magnetic moment vector and the magnetic field? (m) Compute the torque on the loop using the results to parts (k) and (l).

- 53.** A wire is formed into a circle having a diameter of **W** 10.0 cm and is placed in a uniform magnetic field of 3.00 mT. The wire carries a current of 5.00 A. Find (a) the maximum torque on the wire and (b) the range of potential energies of the wire–field system for different orientations of the circle.

Section 29.6 The Hall Effect

- 54.** A Hall-effect probe operates with a 120-mA current. When the probe is placed in a uniform magnetic field of magnitude 0.080 0 T, it produces a Hall voltage of $0.700 \mu\text{V}$. (a) When it is used to measure an unknown magnetic field, the Hall voltage is $0.330 \mu\text{V}$. What is the magnitude of the unknown field? (b) The thickness of the probe in the direction of \vec{B} is 2.00 mm. Find the density of the charge carriers, each of which has charge of magnitude e .

- 55.** In an experiment designed to measure the Earth's **M** magnetic field using the Hall effect, a copper bar 0.500 cm thick is positioned along an east–west direction. Assume $n = 8.46 \times 10^{28}$ electrons/m³ and the plane of the bar is rotated to be perpendicular to the direction of \vec{B} . If a current of 8.00 A in the conductor results in a Hall voltage of 5.10×10^{-12} V, what is the magnitude of the Earth's magnetic field at this location?

Additional Problems

- 56.** Carbon-14 and carbon-12 ions (each with charge of magnitude e) are accelerated in a cyclotron. If the cyclotron has a magnetic field of magnitude 2.40 T, what is the difference in cyclotron frequencies for the two ions?
- 57.** In Niels Bohr's 1913 model of the hydrogen atom, the single electron is in a circular orbit of radius 5.29×10^{-11} m and its speed is 2.19×10^6 m/s. (a) What is the magnitude of the magnetic moment due to the electron's motion? (b) If the electron moves in a horizontal circle, counterclockwise as seen from above, what is the direction of this magnetic moment vector?

- 58.** Heart–lung machines and artificial kidney machines employ electromagnetic blood pumps. The blood is confined to an electrically insulating tube, cylindrical in practice but represented here for simplicity as a rectangle of interior width w and height h . Figure P29.58 shows a rectangular section of blood within the tube. Two electrodes fit into the top and the bottom of the tube. The potential difference between them establishes an electric current through the blood, with current density J over the section of length L shown in Figure P29.58. A perpendicular magnetic field exists in the same region. (a) Explain why this arrangement produces on the liquid a force that is directed along the length of the

pipe. (b) Show that the section of liquid in the magnetic field experiences a pressure increase JLB . (c) After the blood leaves the pump, is it charged? (d) Is it carrying current? (e) Is it magnetized? (The same electromagnetic pump can be used for any fluid that conducts electricity, such as liquid sodium in a nuclear reactor.)

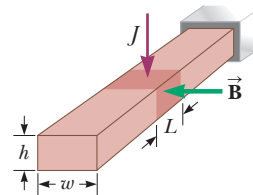

Figure P29.58

- 59.** A particle with positive charge $q = 3.20 \times 10^{-19}$ C **M** moves with a velocity $\vec{v} = (2\hat{i} + 3\hat{j} - \hat{k})$ m/s through a region where both a uniform magnetic field and a uniform electric field exist. (a) Calculate the total force on the moving particle (in unit-vector notation), taking $\vec{B} = (2\hat{i} + 4\hat{j} + \hat{k})$ T and $\vec{E} = (4\hat{i} - \hat{j} - 2\hat{k})$ V/m. (b) What angle does the force vector make with the positive x axis?

- 60.** Figure 29.11 shows a charged particle traveling in a nonuniform magnetic field forming a magnetic bottle. (a) Explain why the positively charged particle in the figure must be moving clockwise when viewed from the right of the figure. The particle travels along a helix whose radius decreases and whose pitch decreases as the particle moves into a stronger magnetic field. If the particle is moving to the right along the x axis, its velocity in this direction will be reduced to zero and it will be reflected from the right-hand side of the bottle, acting as a “magnetic mirror.” The particle ends up bouncing back and forth between the ends of the bottle. (b) Explain qualitatively why the axial velocity is reduced to zero as the particle moves into the region of strong magnetic field at the end of the bottle. (c) Explain why the tangential velocity increases as the particle approaches the end of the bottle. (d) Explain why the orbiting particle has a magnetic dipole moment.

- 61. Review.** The upper portion of the circuit in Figure **AMT** P29.61 is fixed. The horizontal wire at the bottom has a mass of 10.0 g and is 5.00 cm long. This wire hangs in the gravitational field of the Earth from identical light springs connected to the upper portion of the circuit. The springs stretch 0.500 cm under the weight of the

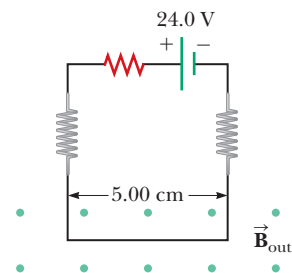

Figure P29.61

wire, and the circuit has a total resistance of $12.0\ \Omega$. When a magnetic field is turned on, directed out of the page, the springs stretch an additional $0.300\ \text{cm}$. Only the horizontal wire at the bottom of the circuit is in the magnetic field. What is the magnitude of the magnetic field?

62. Within a cylindrical region of space of radius $100\ \text{Mm}$, a magnetic field is uniform with a magnitude $25.0\ \mu\text{T}$ and oriented parallel to the axis of the cylinder. The magnetic field is zero outside this cylinder. A cosmic-ray proton traveling at one-tenth the speed of light is heading directly toward the center of the cylinder, moving perpendicular to the cylinder's axis. (a) Find the radius of curvature of the path the proton follows when it enters the region of the field. (b) Explain whether the proton will arrive at the center of the cylinder.
63. **Review.** A proton is at rest at the plane boundary of a region containing a uniform magnetic field B (Fig. P29.63). An alpha particle moving horizontally makes a head-on elastic collision with the proton. Immediately after the collision, both particles enter the magnetic field, moving perpendicular to the direction of the field. The radius of the proton's trajectory is R . The mass of the alpha particle is four times that of the proton, and its charge is twice that of the proton. Find the radius of the alpha particle's trajectory.

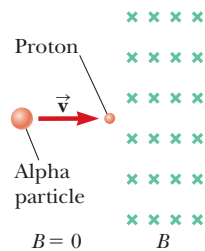

Figure P29.63

64. (a) A proton moving with velocity $\vec{v} = v_i \hat{i}$ experiences a magnetic force $\vec{F} = F_i \hat{j}$. Explain what you can and cannot infer about \vec{B} from this information. (b) **What If?** In terms of F_i , what would be the force on a proton in the same field moving with velocity $\vec{v} = -v_i \hat{i}$? (c) What would be the force on an electron in the same field moving with velocity $\vec{v} = -v_i \hat{i}$?
65. **Review.** A 0.200-kg metal rod carrying a current of $10.0\ \text{A}$ glides on two horizontal rails $0.500\ \text{m}$ apart. If the coefficient of kinetic friction between the rod and rails is 0.100 , what vertical magnetic field is required to keep the rod moving at a constant speed?
66. **Review.** A metal rod of mass m carrying a current I glides on two horizontal rails a distance d apart. If the coefficient of kinetic friction between the rod and rails is μ , what vertical magnetic field is required to keep the rod moving at a constant speed?
67. A proton having an initial velocity of $20.0 \hat{i}\ \text{Mm/s}$ enters a uniform magnetic field of magnitude $0.300\ \text{T}$

with a direction perpendicular to the proton's velocity. It leaves the field-filled region with velocity $-20.0 \hat{j}\ \text{Mm/s}$. Determine (a) the direction of the magnetic field, (b) the radius of curvature of the proton's path while in the field, (c) the distance the proton traveled in the field, and (d) the time interval during which the proton is in the field.

68. Model the electric motor in a handheld electric mixer as a single flat, compact, circular coil carrying electric current in a region where a magnetic field is produced by an external permanent magnet. You need consider only one instant in the operation of the motor. (We will consider motors again in Chapter 31.) Make order-of-magnitude estimates of (a) the magnetic field, (b) the torque on the coil, (c) the current in the coil, (d) the coil's area, and (e) the number of turns in the coil. The input power to the motor is electric, given by $P = I\Delta V$, and the useful output power is mechanical, $P = \tau\omega$.
69. **AMT** A nonconducting sphere has mass $80.0\ \text{g}$ and radius $20.0\ \text{cm}$. A flat, compact coil of wire with five turns is wrapped tightly around it, with each turn concentric with the sphere. The sphere is placed on an inclined plane that slopes downward to the left (Fig. P29.69), making an angle θ with the horizontal so that the coil is parallel to the inclined plane. A uniform magnetic field of $0.350\ \text{T}$ vertically upward exists in the region of the sphere. (a) What current in the coil will enable the sphere to rest in equilibrium on the inclined plane? (b) Show that the result does not depend on the value of θ .

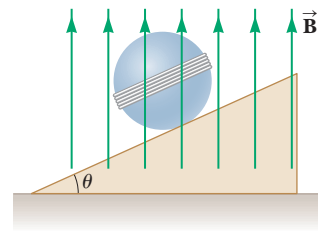

Figure P29.69

70. **Why is the following situation impossible?** Figure P29.70 shows an experimental technique for altering the direction of travel for a charged particle. A particle of charge $q = 1.00\ \mu\text{C}$ and mass $m = 2.00 \times 10^{-13}\ \text{kg}$ enters the bottom of the region of uniform magnetic field at speed $v = 2.00 \times 10^5\ \text{m/s}$, with a velocity vector

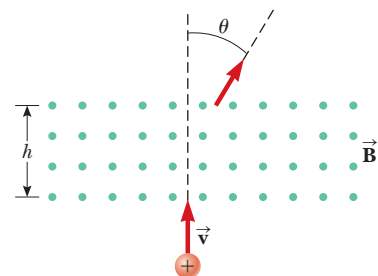

Figure P29.70

perpendicular to the field lines. The magnetic force on the particle causes its direction of travel to change so that it leaves the region of the magnetic field at the top traveling at an angle from its original direction. The magnetic field has magnitude $B = 0.400\text{ T}$ and is directed out of the page. The length h of the magnetic field region is 0.110 m . An experimenter performs the technique and measures the angle θ at which the particles exit the top of the field. She finds that the angles of deviation are exactly as predicted.

71. Figure P29.71 shows a schematic representation of an apparatus that can be used to measure magnetic fields. A rectangular coil of wire contains N turns and has a width w . The coil is attached to one arm of a balance and is suspended between the poles of a magnet. The magnetic field is uniform and perpendicular to the plane of the coil. The system is first balanced when the current in the coil is zero. When the switch is closed and the coil carries a current I , a mass m must be added to the right side to balance the system. (a) Find an expression for the magnitude of the magnetic field. (b) Why is the result independent of the vertical dimensions of the coil? (c) Suppose the coil has 50 turns and a width of 5.00 cm . When the switch is closed, the coil carries a current of 0.300 A , and a mass of 20.0 g must be added to the right side to balance the system. What is the magnitude of the magnetic field?

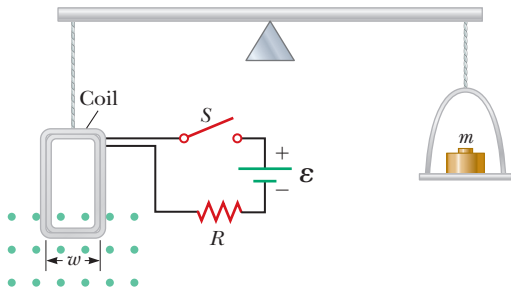

Figure P29.71

72. A heart surgeon monitors the flow rate of blood through an artery using an electromagnetic flowmeter (Fig. P29.72). Electrodes A and B make contact with the outer surface of the blood vessel, which has a diameter of 3.00 mm . (a) For a magnetic field magnitude of 0.0400 T , an emf of $160\text{ }\mu\text{V}$ appears between the electrodes. Calculate the speed of the blood. (b) Explain why electrode A has to be positive as shown. (c) Does the sign of the emf depend on whether the mobile ions in the blood are predominantly positively or negatively charged? Explain.

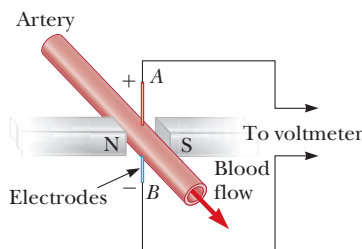

Figure P29.72

73. A uniform magnetic field of magnitude 0.150 T is directed along the positive x axis. A positron moving at a speed of $5.00 \times 10^6\text{ m/s}$ enters the field along a direction that makes an angle of $\theta = 85.0^\circ$ with the x axis (Fig. P29.73). The motion of the particle is expected to be a helix as described in Section 29.2. Calculate (a) the pitch p and (b) the radius r of the trajectory as defined in Figure P29.73.

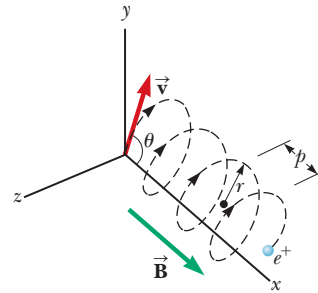

Figure P29.73

74. **Review.** (a) Show that a magnetic dipole in a uniform magnetic field, displaced from its equilibrium orientation and released, can oscillate as a torsional pendulum (Section 15.5) in simple harmonic motion. (b) Is this statement true for all angular displacements, for all displacements less than 180° , or only for small angular displacements? Explain. (c) Assume the dipole is a compass needle—a light bar magnet—with a magnetic moment of magnitude μ . It has moment of inertia I about its center, where it is mounted on a frictionless, vertical axle, and it is placed in a horizontal magnetic field of magnitude B . Determine its frequency of oscillation. (d) Explain how the compass needle can be conveniently used as an indicator of the magnitude of the external magnetic field. (e) If its frequency is 0.680 Hz in the Earth's local field, with a horizontal component of $39.2\text{ }\mu\text{T}$, what is the magnitude of a field parallel to the needle in which its frequency of oscillation is 4.90 Hz ?
75. The accompanying table shows measurements of the Hall voltage and corresponding magnetic field for a probe used to measure magnetic fields. (a) Plot these data and deduce a relationship between the two variables. (b) If the measurements were taken with a current of 0.200 A and the sample is made from a material having a charge-carrier density of $1.00 \times 10^{26}\text{ carriers/m}^3$, what is the thickness of the sample?

ΔV_H (μV)	B (T)
0	0.00
11	0.10
19	0.20
28	0.30
42	0.40
50	0.50
61	0.60
68	0.70
79	0.80
90	0.90
102	1.00

76. A metal rod having a mass per unit length λ carries a current I . The rod hangs from two wires in a uniform vertical magnetic field as shown in Figure P29.76. The wires make an angle θ with the vertical when in equilibrium. Determine the magnitude of the magnetic field.

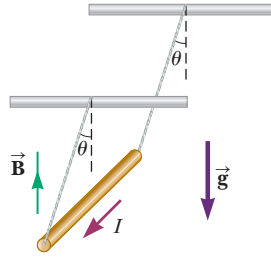

Figure P29.76

Challenge Problems

77. Consider an electron orbiting a proton and maintained in a fixed circular path of radius $R = 5.29 \times 10^{-11}$ m by the Coulomb force. Treat the orbiting particle as a current loop. Calculate the resulting torque when the electron-proton system is placed in a magnetic field of 0.400 T directed perpendicular to the magnetic moment of the loop.
78. Protons having a kinetic energy of 5.00 MeV ($1 \text{ eV} = 1.60 \times 10^{-19}$ J) are moving in the positive x direction and enter a magnetic field $\vec{B} = 0.050 \text{ T} \hat{k}$ directed out of the plane of the page and extending from $x = 0$ to $x = 1.00$ m as shown in Figure P29.78. (a) Ignoring relativistic effects, find the angle α between the initial velocity vector of the proton beam and the velocity vector after the beam emerges from the field. (b) Calculate the y component of the protons' momenta as they leave the magnetic field.

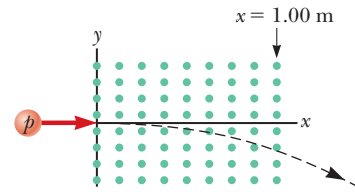

Figure P29.78

79. **Review.** A wire having a linear mass density of 1.00 g/cm is placed on a horizontal surface that has a coefficient of kinetic friction of 0.200. The wire carries a current of 1.50 A toward the east and slides horizontally to the north at constant velocity. What are (a) the magnitude and (b) the direction of the smallest magnetic field that enables the wire to move in this fashion?
80. A proton moving in the plane of the page has a kinetic energy of 6.00 MeV. A magnetic field of magnitude $B = 1.00$ T is directed into the page. The proton enters the magnetic field with its velocity vector at an angle $\theta = 45.0^\circ$ to the linear boundary of the field as shown in Figure P29.80. (a) Find x , the distance from the point of entry to where the proton will leave the field. (b) Determine θ' , the angle between the boundary and the proton's velocity vector as it leaves the field.

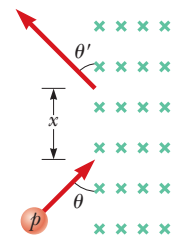

Figure P29.80

Sources of the
Magnetic Field

- 30.1 The Biot–Savart Law
- 30.2 The Magnetic Force Between Two Parallel Conductors
- 30.3 Ampère's Law
- 30.4 The Magnetic Field of a Solenoid
- 30.5 Gauss's Law in Magnetism
- 30.6 Magnetism in Matter



A cardiac catheterization laboratory stands ready to receive a patient suffering from atrial fibrillation. The large white objects on either side of the operating table are strong magnets that place the patient in a magnetic field. The electrophysiologist performing a catheter ablation procedure sits at a computer in the room to the left. With guidance from the magnetic field, he or she uses a joystick and other controls to thread the magnetically sensitive tip of a cardiac catheter through blood vessels and into the chambers of the heart. (©Courtesy of Stereotaxis, Inc.)

In Chapter 29, we discussed the magnetic force exerted on a charged particle moving in a magnetic field. To complete the description of the magnetic interaction, this chapter explores the origin of the magnetic field, moving charges. We begin by showing how to use the law of Biot and Savart to calculate the magnetic field produced at some point in space by a small current element. This formalism is then used to calculate the total magnetic field due to various current distributions. Next, we show how to determine the force between two current-carrying conductors, leading to the definition of the ampere. We also introduce Ampère's law, which is useful in calculating the magnetic field of a highly symmetric configuration carrying a steady current.

This chapter is also concerned with the complex processes that occur in magnetic materials. All magnetic effects in matter can be explained on the basis of atomic magnetic moments, which arise both from the orbital motion of electrons and from an intrinsic property of electrons known as spin.

30.1 The Biot–Savart Law

Shortly after Oersted's discovery in 1819 that a compass needle is deflected by a current-carrying conductor, Jean-Baptiste Biot (1774–1862) and Félix Savart (1791–1841) performed quantitative experiments on the force exerted by an electric current on a nearby magnet. From their experimental results, Biot and Savart arrived at a mathematical expression that gives the magnetic field at some point in space

in terms of the current that produces the field. That expression is based on the following experimental observations for the magnetic field $d\vec{\mathbf{B}}$ at a point P associated with a length element $d\vec{\mathbf{s}}$ of a wire carrying a steady current I (Fig. 30.1):

- The vector $d\vec{\mathbf{B}}$ is perpendicular both to $d\vec{\mathbf{s}}$ (which points in the direction of the current) and to the unit vector $\hat{\mathbf{r}}$ directed from $d\vec{\mathbf{s}}$ toward P .
- The magnitude of $d\vec{\mathbf{B}}$ is inversely proportional to r^2 , where r is the distance from $d\vec{\mathbf{s}}$ to P .
- The magnitude of $d\vec{\mathbf{B}}$ is proportional to the current I and to the magnitude ds of the length element $d\vec{\mathbf{s}}$.
- The magnitude of $d\vec{\mathbf{B}}$ is proportional to $\sin \theta$, where θ is the angle between the vectors $d\vec{\mathbf{s}}$ and $\hat{\mathbf{r}}$.

These observations are summarized in the mathematical expression known today as the **Biot–Savart law**:

$$d\vec{\mathbf{B}} = \frac{\mu_0}{4\pi} \frac{I d\vec{\mathbf{s}} \times \hat{\mathbf{r}}}{r^2} \quad (30.1)$$

where μ_0 is a constant called the **permeability of free space**:

$$\mu_0 = 4\pi \times 10^{-7} \text{ T} \cdot \text{m/A} \quad (30.2)$$

Notice that the field $d\vec{\mathbf{B}}$ in Equation 30.1 is the field created at a point by the current in only a small length element $d\vec{\mathbf{s}}$ of the conductor. To find the *total* magnetic field $\vec{\mathbf{B}}$ created at some point by a current of finite size, we must sum up contributions from all current elements $I d\vec{\mathbf{s}}$ that make up the current. That is, we must evaluate $\vec{\mathbf{B}}$ by integrating Equation 30.1:

$$\vec{\mathbf{B}} = \frac{\mu_0 I}{4\pi} \int \frac{d\vec{\mathbf{s}} \times \hat{\mathbf{r}}}{r^2} \quad (30.3)$$

where the integral is taken over the entire current distribution. This expression must be handled with special care because the integrand is a cross product and therefore a vector quantity. We shall see one case of such an integration in Example 30.1.

Although the Biot–Savart law was discussed for a current-carrying wire, it is also valid for a current consisting of charges flowing through space such as the particle beam in an accelerator. In that case, $d\vec{\mathbf{s}}$ represents the length of a small segment of space in which the charges flow.

Interesting similarities and differences exist between Equation 30.1 for the magnetic field due to a current element and Equation 23.9 for the electric field due to a point charge. The magnitude of the magnetic field varies as the inverse square of the distance from the source, as does the electric field due to a point charge. The directions of the two fields are quite different, however. The electric field created by a point charge is radial, but the magnetic field created by a current element is perpendicular to both the length element $d\vec{\mathbf{s}}$ and the unit vector $\hat{\mathbf{r}}$ as described by the cross product in Equation 30.1. Hence, if the conductor lies in the plane of the page as shown in Figure 30.1, $d\vec{\mathbf{B}}$ points out of the page at P and into the page at P' .

Another difference between electric and magnetic fields is related to the source of the field. An electric field is established by an isolated electric charge. The Biot–Savart law gives the magnetic field of an isolated current element at some point, but such an isolated current element cannot exist the way an isolated electric charge can. A current element *must* be part of an extended current distribution because a complete circuit is needed for charges to flow. Therefore,

Pitfall Prevention 30.1

The Biot–Savart Law The magnetic field described by the Biot–Savart law is the field *due to* a given current-carrying conductor. Do not confuse this field with any *external* field that may be applied to the conductor from some other source.

◀ Biot–Savart law

◀ Permeability of free space

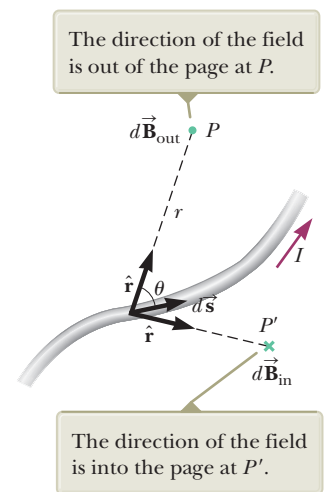

Figure 30.1 The magnetic field $d\vec{\mathbf{B}}$ at a point due to the current I through a length element $d\vec{\mathbf{s}}$ is given by the Biot–Savart law.

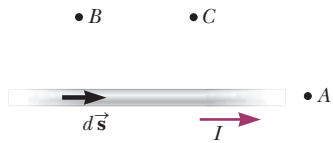

Figure 30.2 (Quick Quiz 30.1) Where is the magnetic field due to the current element the greatest?

the Biot–Savart law (Eq. 30.1) is only the first step in a calculation of a magnetic field; it must be followed by an integration over the current distribution as in Equation 30.3.

Quick Quiz 30.1 Consider the magnetic field due to the current in the wire shown in Figure 30.2. Rank the points A, B, and C in terms of magnitude of the magnetic field that is due to the current in just the length element $d\vec{s}$ shown from greatest to least.

Example 30.1

Magnetic Field Surrounding a Thin, Straight Conductor

Consider a thin, straight wire of finite length carrying a constant current I and placed along the x axis as shown in Figure 30.3. Determine the magnitude and direction of the magnetic field at point P due to this current.

SOLUTION

Conceptualize From the Biot–Savart law, we expect that the magnitude of the field is proportional to the current in the wire and decreases as the distance a from the wire to point P increases. We also expect the field to depend on the angles θ_1 and θ_2 in Figure 30.3b. We place the origin at O and let point P be along the positive y axis, with $\hat{\mathbf{k}}$ being a unit vector pointing out of the page.

Categorize We are asked to find the magnetic field due to a simple current distribution, so this example is a typical problem for which the Biot–Savart law is appropriate. We must find the field contribution from a small element of current and then integrate over the current distribution.

Analyze Let's start by considering a length element $d\vec{s}$ located a distance r from P . The direction of the magnetic field at point P due to the current in this element is out of the page because $d\vec{s} \times \hat{\mathbf{r}}$ is out of the page. In fact, because *all* the current elements $I d\vec{s}$ lie in the plane of the page, they all produce a magnetic field directed out of the page at point P . Therefore, the direction of the magnetic field at point P is out of the page and we need only find the magnitude of the field.

Evaluate the cross product in the Biot–Savart law:

$$d\vec{s} \times \hat{\mathbf{r}} = |d\vec{s} \times \hat{\mathbf{r}}| \hat{\mathbf{k}} = \left[dx \sin \left(\frac{\pi}{2} - \theta \right) \right] \hat{\mathbf{k}} = (dx \cos \theta) \hat{\mathbf{k}}$$

Substitute into Equation 30.1:

$$(1) \quad d\vec{\mathbf{B}} = (dB) \hat{\mathbf{k}} = \frac{\mu_0 I}{4\pi} \frac{dx \cos \theta}{r^2} \hat{\mathbf{k}}$$

From the geometry in Figure 30.3a, express r in terms of θ :

$$(2) \quad r = \frac{a}{\cos \theta}$$

Notice that $\tan \theta = -x/a$ from the right triangle in Figure 30.3a (the negative sign is necessary because $d\vec{s}$ is located at a negative value of x) and solve for x :

$$x = -a \tan \theta$$

Find the differential dx :

$$(3) \quad dx = -a \sec^2 \theta \, d\theta = -\frac{a \, d\theta}{\cos^2 \theta}$$

Substitute Equations (2) and (3) into the expression for the z component of the field from Equation (1):

$$(4) \quad dB = -\frac{\mu_0 I}{4\pi} \left(\frac{a \, d\theta}{\cos^2 \theta} \right) \left(\frac{\cos^2 \theta}{a^2} \right) \cos \theta = -\frac{\mu_0 I}{4\pi a} \cos \theta \, d\theta$$

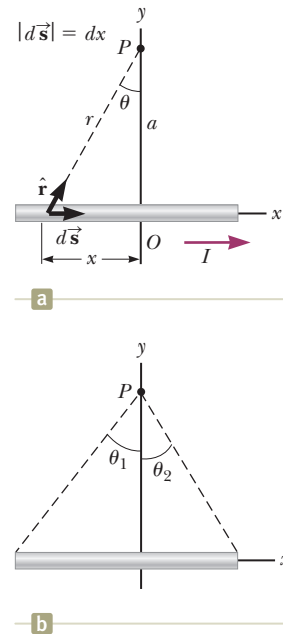

Figure 30.3 (Example 30.1) (a) A thin, straight wire carrying a current I . (b) The angles θ_1 and θ_2 used for determining the net field.

30.1 continued

Integrate Equation (4) over all length elements on the wire, where the subtending angles range from θ_1 to θ_2 as defined in Figure 30.3b:

$$B = -\frac{\mu_0 I}{4\pi a} \int_{\theta_1}^{\theta_2} \cos \theta \, d\theta = \frac{\mu_0 I}{4\pi a} (\sin \theta_1 - \sin \theta_2) \quad (30.4)$$

Finalize We can use this result to find the magnitude of the magnetic field of *any* straight current-carrying wire if we know the geometry and hence the angles θ_1 and θ_2 . Consider the special case of an infinitely long, straight wire. If the wire in Figure 30.3b becomes infinitely long, we see that $\theta_1 = \pi/2$ and $\theta_2 = -\pi/2$ for length elements ranging between positions $x = -\infty$ and $x = +\infty$. Because $(\sin \theta_1 - \sin \theta_2) = [\sin \pi/2 - \sin (-\pi/2)] = 2$, Equation 30.4 becomes

$$B = \frac{\mu_0 I}{2\pi a} \quad (30.5)$$

Equations 30.4 and 30.5 both show that the magnitude of the magnetic field is proportional to the current and decreases with increasing distance from the wire, as expected. Equation 30.5 has the same mathematical form as the expression for the magnitude of the electric field due to a long charged wire (see Eq. 24.7).

Example 30.2 Magnetic Field Due to a Curved Wire Segment

Calculate the magnetic field at point O for the current-carrying wire segment shown in Figure 30.4. The wire consists of two straight portions and a circular arc of radius a , which subtends an angle θ .

SOLUTION

Conceptualize The magnetic field at O due to the current in the straight segments AA' and CC' is zero because $d\vec{s}$ is parallel to \hat{r} along these paths, which means that $d\vec{s} \times \hat{r} = 0$ for these paths. Therefore, we expect the magnetic field at O to be due only to the current in the curved portion of the wire.

Categorize Because we can ignore segments AA' and CC' , this example is categorized as an application of the Biot–Savart law to the curved wire segment AC .

Analyze Each length element $d\vec{s}$ along path AC is at the same distance a from O , and the current in each contributes a field element $d\vec{B}$ directed into the page at O . Furthermore, at every point on AC , $d\vec{s}$ is perpendicular to \hat{r} ; hence, $|d\vec{s} \times \hat{r}| = ds$.

From Equation 30.1, find the magnitude of the field at O due to the current in an element of length ds :

$$dB = \frac{\mu_0}{4\pi} \frac{I ds}{a^2}$$

Integrate this expression over the curved path AC , noting that I and a are constants:

$$B = \frac{\mu_0 I}{4\pi a^2} \int ds = \frac{\mu_0 I}{4\pi a^2} s$$

From the geometry, note that $s = a\theta$ and substitute:

$$B = \frac{\mu_0 I}{4\pi a^2} (a\theta) = \frac{\mu_0 I}{4\pi a} \theta \quad (30.6)$$

Finalize Equation 30.6 gives the magnitude of the magnetic field at O . The direction of \vec{B} is into the page at O because $d\vec{s} \times \hat{r}$ is into the page for every length element.

WHAT IF? What if you were asked to find the magnetic field at the center of a circular wire loop of radius R that carries a current I ? Can this question be answered at this point in our understanding of the source of magnetic fields?

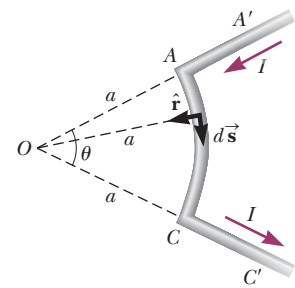

Figure 30.4 (Example 30.2) The length of the curved segment AC is s .

continued

30.2 continued

Answer Yes, it can. The straight wires in Figure 30.4 do not contribute to the magnetic field. The only contribution is from the curved segment. As the angle θ increases, the curved segment becomes a full circle when $\theta = 2\pi$. Therefore, you can find the magnetic field at the center of a wire loop by letting $\theta = 2\pi$ in Equation 30.6:

$$B = \frac{\mu_0 I}{4\pi a} 2\pi = \frac{\mu_0 I}{2a}$$

This result is a limiting case of a more general result discussed in Example 30.3.

Example 30.3 Magnetic Field on the Axis of a Circular Current Loop

Consider a circular wire loop of radius a located in the yz plane and carrying a steady current I as in Figure 30.5. Calculate the magnetic field at an axial point P a distance x from the center of the loop.

SOLUTION

Conceptualize Compare this problem to Example 23.8 for the electric field due to a ring of charge. Figure 30.5 shows the magnetic field contribution $d\vec{B}$ at P due to a single current element at the top of the ring. This field vector can be resolved into components dB_x parallel to the axis of the ring and dB_\perp perpendicular to the axis. Think about the magnetic field contributions from a current element at the bottom of the loop. Because of the symmetry of the situation, the perpendicular components of the field due to elements at the top and bottom of the ring cancel. This cancellation occurs for all pairs of segments around the ring, so we can ignore the perpendicular component of the field and focus solely on the parallel components, which simply add.

Categorize We are asked to find the magnetic field due to a simple current distribution, so this example is a typical problem for which the Biot–Savart law is appropriate.

Analyze In this situation, every length element $d\vec{s}$ is perpendicular to the vector \hat{r} at the location of the element. Therefore, for any element, $|d\vec{s} \times \hat{r}| = (ds)(1) \sin 90^\circ = ds$. Furthermore, all length elements around the loop are at the same distance r from P , where $r^2 = a^2 + x^2$.

Use Equation 30.1 to find the magnitude of $d\vec{B}$ due to the current in any length element $d\vec{s}$:

$$dB = \frac{\mu_0 I}{4\pi} \frac{|d\vec{s} \times \hat{r}|}{r^2} = \frac{\mu_0 I}{4\pi} \frac{ds}{(a^2 + x^2)}$$

Find the x component of the field element:

$$dB_x = \frac{\mu_0 I}{4\pi} \frac{ds}{(a^2 + x^2)} \cos \theta$$

Integrate over the entire loop:

$$B_x = \oint dB_x = \frac{\mu_0 I}{4\pi} \oint \frac{ds \cos \theta}{a^2 + x^2}$$

From the geometry, evaluate $\cos \theta$:

$$\cos \theta = \frac{a}{(a^2 + x^2)^{1/2}}$$

Substitute this expression for $\cos \theta$ into the integral and note that x and a are both constant:

$$B_x = \frac{\mu_0 I}{4\pi} \oint \frac{ds}{a^2 + x^2} \left[\frac{a}{(a^2 + x^2)^{1/2}} \right] = \frac{\mu_0 I}{4\pi} \frac{a}{(a^2 + x^2)^{3/2}} \oint ds$$

Integrate around the loop:

$$B_x = \frac{\mu_0 I}{4\pi} \frac{a}{(a^2 + x^2)^{3/2}} (2\pi a) = \frac{\mu_0 I a^2}{2(a^2 + x^2)^{3/2}} \quad (30.7)$$

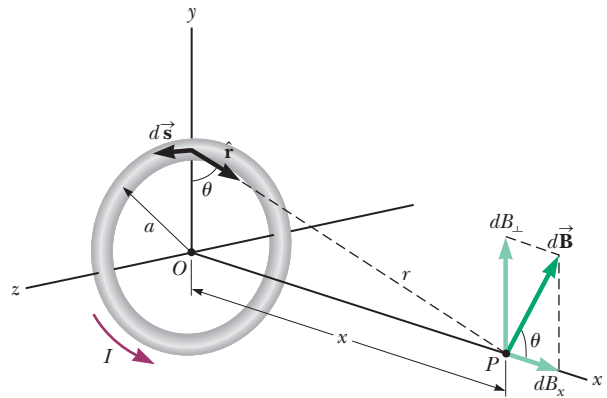

Figure 30.5 (Example 30.3) Geometry for calculating the magnetic field at a point P lying on the axis of a current loop. By symmetry, the total field \vec{B} is along this axis.

30.3 continued

Finalize To find the magnetic field at the center of the loop, set $x = 0$ in Equation 30.7. At this special point,

$$B = \frac{\mu_0 I}{2a} \quad (\text{at } x = 0) \quad (30.8)$$

which is consistent with the result of the **What If?** feature of Example 30.2.

The pattern of magnetic field lines for a circular current loop is shown in Figure 30.6a. For clarity, the lines are drawn for only the plane that contains the axis of the loop. The field-line pattern is axially symmetric and looks like the pattern around a bar magnet, which is shown in Figure 30.6b.

WHAT IF? What if we consider points on the x axis very far from the loop? How does the magnetic field behave at these distant points?

Answer In this case, in which $x \gg a$, we can neglect the term a^2 in the denominator of Equation 30.7 and obtain

$$B \approx \frac{\mu_0 I a^2}{2x^3} \quad (\text{for } x \gg a) \quad (30.9)$$

The magnitude of the magnetic moment μ of the loop is defined as the product of current and loop area (see Eq. 29.15): $\mu = I(\pi a^2)$ for our circular loop. We can express Equation 30.9 as

$$B \approx \frac{\mu_0}{2\pi} \frac{\mu}{x^3} \quad (30.10)$$

This result is similar in form to the expression for the electric field due to an electric dipole, $E = k_e(p/y^3)$ (see Example 23.6), where $p = 2aq$ is the electric dipole moment as defined in Equation 26.16.

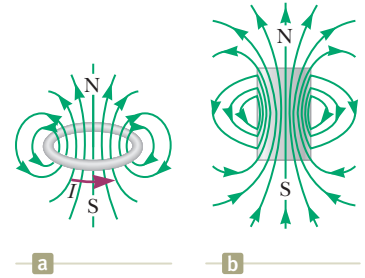

Figure 30.6 (Example 30.3) (a) Magnetic field lines surrounding a current loop. (b) Magnetic field lines surrounding a bar magnet. Notice the similarity between this line pattern and that of a current loop.

30.2 The Magnetic Force Between Two Parallel Conductors

In Chapter 29, we described the magnetic force that acts on a current-carrying conductor placed in an external magnetic field. Because a current in a conductor sets up its own magnetic field, it is easy to understand that two current-carrying conductors exert magnetic forces on each other. One wire establishes the magnetic field and the other wire is modeled as a collection of particles in a magnetic field. Such forces between wires can be used as the basis for defining the ampere and the coulomb.

Consider two long, straight, parallel wires separated by a distance a and carrying currents I_1 and I_2 in the same direction as in Figure 30.7. Let's determine the force exerted on one wire due to the magnetic field set up by the other wire. Wire 2, which carries a current I_2 and is identified arbitrarily as the source wire, creates a magnetic field \vec{B}_2 at the location of wire 1, the test wire. The magnitude of this magnetic field is the same at all points on wire 1. The direction of \vec{B}_2 is perpendicular to wire 1 as shown in Figure 30.7. According to Equation 29.10, the magnetic force on a length ℓ of wire 1 is $\vec{F}_1 = I_1 \vec{\ell} \times \vec{B}_2$. Because $\vec{\ell}$ is perpendicular to \vec{B}_2 in this situation, the magnitude of \vec{F}_1 is $F_1 = I_1 \ell B_2$. Because the magnitude of \vec{B}_2 is given by Equation 30.5,

$$F_1 = I_1 \ell B_2 = I_1 \ell \left(\frac{\mu_0 I_2}{2\pi a} \right) = \frac{\mu_0 I_1 I_2}{2\pi a} \ell \quad (30.11)$$

The direction of \vec{F}_1 is toward wire 2 because $\vec{\ell} \times \vec{B}_2$ is in that direction. When the field set up at wire 2 by wire 1 is calculated, the force \vec{F}_2 acting on wire 2 is found to be equal in magnitude and opposite in direction to \vec{F}_1 , which is what we expect because Newton's third law must be obeyed. When the currents are in opposite directions (that is, when one of the currents is reversed in Fig. 30.7), the forces

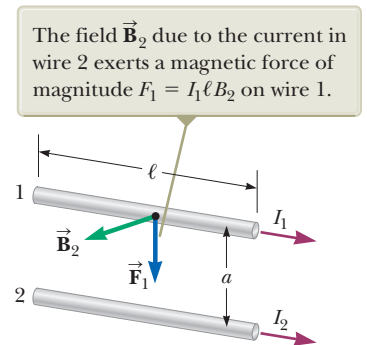

Figure 30.7 Two parallel wires that each carry a steady current exert a magnetic force on each other. The force is attractive if the currents are parallel (as shown) and repulsive if the currents are antiparallel.

are reversed and the wires repel each other. Hence, parallel conductors carrying currents in the *same* direction *attract* each other, and parallel conductors carrying currents in *opposite* directions *repel* each other.

Because the magnitudes of the forces are the same on both wires, we denote the magnitude of the magnetic force between the wires as simply F_B . We can rewrite this magnitude in terms of the force per unit length:

$$\frac{F_B}{\ell} = \frac{\mu_0 I_1 I_2}{2\pi a} \quad (30.12)$$

The force between two parallel wires is used to define the **ampere** as follows:

Definition of the ampere ▶

When the magnitude of the force per unit length between two long, parallel wires that carry identical currents and are separated by 1 m is 2×10^{-7} N/m, the current in each wire is defined to be 1 A.

The value 2×10^{-7} N/m is obtained from Equation 30.12 with $I_1 = I_2 = 1$ A and $a = 1$ m. Because this definition is based on a force, a mechanical measurement can be used to standardize the ampere. For instance, the National Institute of Standards and Technology uses an instrument called a *current balance* for primary current measurements. The results are then used to standardize other, more conventional instruments such as ammeters.

The SI unit of charge, the **coulomb**, is defined in terms of the ampere: When a conductor carries a steady current of 1 A, the quantity of charge that flows through a cross section of the conductor in 1 s is 1 C.

In deriving Equations 30.11 and 30.12, we assumed both wires are long compared with their separation distance. In fact, only one wire needs to be long. The equations accurately describe the forces exerted on each other by a long wire and a straight, parallel wire of limited length ℓ .

- Quick Quiz 30.2** A loose spiral spring carrying no current is hung from a ceiling.
 ⋮ When a switch is thrown so that a current exists in the spring, do the coils
 ⋮
 • (a) move closer together, (b) move farther apart, or (c) not move at all?

Example 30.4 Suspending a Wire **AM**

Two infinitely long, parallel wires are lying on the ground a distance $a = 1.00$ cm apart as shown in Figure 30.8a. A third wire, of length $L = 10.0$ m and mass 400 g, carries a current of $I_1 = 100$ A and is levitated above the first two wires, at a horizontal position midway between them. The infinitely long wires carry equal currents I_2 in the same direction, but in the direction opposite that in the levitated wire. What current must the infinitely long wires carry so that the three wires form an equilateral triangle?

SOLUTION

Conceptualize Because the current in the short wire is opposite those in the long wires, the short wire is repelled from both of the others. Imagine the currents in the long wires in Figure 30.8a are increased. The repulsive force becomes stronger, and the levitated wire rises to the point at which the wire is once again levitated in equilibrium at a higher position. Figure 30.8b shows the desired situation with the three wires forming an equilateral triangle.

Categorize Because the levitated wire is subject to forces but does not accelerate, it is modeled as a *particle in equilibrium*.

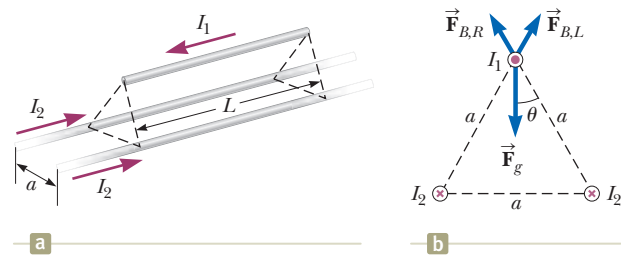

Figure 30.8 (Example 30.4) (a) Two current-carrying wires lie on the ground and suspend a third wire in the air by magnetic forces. (b) End view. In the situation described in the example, the three wires form an equilateral triangle. The two magnetic forces on the levitated wire are $\vec{F}_{B,L}$, the force due to the left-hand wire on the ground, and $\vec{F}_{B,R}$, the force due to the right-hand wire. The gravitational force \vec{F}_g on the levitated wire is also shown.

▶ 30.4 continued

Analyze The horizontal components of the magnetic forces on the levitated wire cancel. The vertical components are both positive and add together. Choose the z axis to be upward through the top wire in Figure 30.8b and in the plane of the page.

Find the total magnetic force in the upward direction on the levitated wire:

$$\vec{\mathbf{F}}_B = 2 \left(\frac{\mu_0 I_1 I_2}{2\pi a} \ell \right) \cos \theta \hat{\mathbf{k}} = \frac{\mu_0 I_1 I_2}{\pi a} \ell \cos \theta \hat{\mathbf{k}}$$

Find the gravitational force on the levitated wire:

$$\vec{\mathbf{F}}_g = -mg\hat{\mathbf{k}}$$

Apply the particle in equilibrium model by adding the forces and setting the net force equal to zero:

$$\sum \vec{\mathbf{F}} = \vec{\mathbf{F}}_B + \vec{\mathbf{F}}_g = \frac{\mu_0 I_1 I_2}{\pi a} \ell \cos \theta \hat{\mathbf{k}} - mg\hat{\mathbf{k}} = 0$$

Solve for the current in the wires on the ground:

$$I_2 = \frac{mg\pi a}{\mu_0 I_1 \ell \cos \theta}$$

Substitute numerical values:

$$\begin{aligned} I_2 &= \frac{(0.400 \text{ kg})(9.80 \text{ m/s}^2)\pi(0.010 \text{ m})}{(4\pi \times 10^{-7} \text{ T} \cdot \text{m/A})(100 \text{ A})(10.0 \text{ m}) \cos 30.0^\circ} \\ &= \mathbf{113 \text{ A}} \end{aligned}$$

Finalize The currents in all wires are on the order of 10^2 A. Such large currents would require specialized equipment. Therefore, this situation would be difficult to establish in practice. Is the equilibrium of wire 1 stable or unstable?

30.3 Ampère's Law

Looking back, we can see that the result of Example 30.1 is important because a current in the form of a long, straight wire occurs often. Figure 30.9 is a perspective view of the magnetic field surrounding a long, straight, current-carrying wire. Because of the wire's symmetry, the magnetic field lines are circles concentric with the wire and lie in planes perpendicular to the wire. The magnitude of $\vec{\mathbf{B}}$ is constant on any circle of radius a and is given by Equation 30.5. A convenient rule for determining the direction of $\vec{\mathbf{B}}$ is to grasp the wire with the right hand, positioning the thumb along the direction of the current. The four fingers wrap in the direction of the magnetic field.

Figure 30.9 also shows that the magnetic field line has no beginning and no end. Rather, it forms a closed loop. That is a major difference between magnetic field lines and electric field lines, which begin on positive charges and end on negative charges. We will explore this feature of magnetic field lines further in Section 30.5.

Oersted's 1819 discovery about deflected compass needles demonstrates that a current-carrying conductor produces a magnetic field. Figure 30.10a (page 912) shows how this effect can be demonstrated in the classroom. Several compass needles are placed in a horizontal plane near a long, vertical wire. When no current is present in the wire, all the needles point in the same direction (that of the horizontal component of the Earth's magnetic field) as expected. When the wire carries a strong, steady current, the needles all deflect in a direction tangent to the circle as in Figure 30.10b. These observations demonstrate that the direction of the magnetic field produced by the current in the wire is consistent with the right-hand rule described in Figure 30.9. When the current is reversed, the needles in Figure 30.10b also reverse.

Now let's evaluate the product $\vec{\mathbf{B}} \cdot d\vec{\mathbf{s}}$ for a small length element $d\vec{\mathbf{s}}$ on the circular path defined by the compass needles and sum the products for all elements

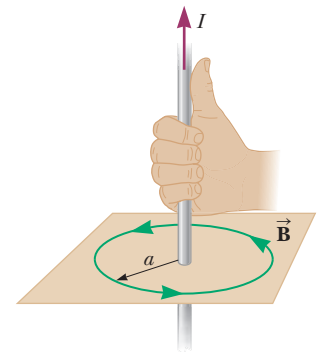

Figure 30.9 The right-hand rule for determining the direction of the magnetic field surrounding a long, straight wire carrying a current. Notice that the magnetic field lines form circles around the wire.



Andre-Marie Ampère
French Physicist (1775–1836)

Ampère is credited with the discovery of electromagnetism, which is the relationship between electric currents and magnetic fields. Ampère's genius, particularly in mathematics, became evident by the time he was 12 years old; his personal life, however, was filled with tragedy. His father, a wealthy city official, was guillotined during the French Revolution, and his wife died young, in 1803. Ampère died at the age of 61 of pneumonia.

Pitfall Prevention 30.2

Avoiding Problems with Signs

When using Ampère's law, apply the following right-hand rule. Point your thumb in the direction of the current through the amperian loop. Your curled fingers then point in the direction that you should integrate when traversing the loop to avoid having to define the current as negative.

Ampère's law ▶

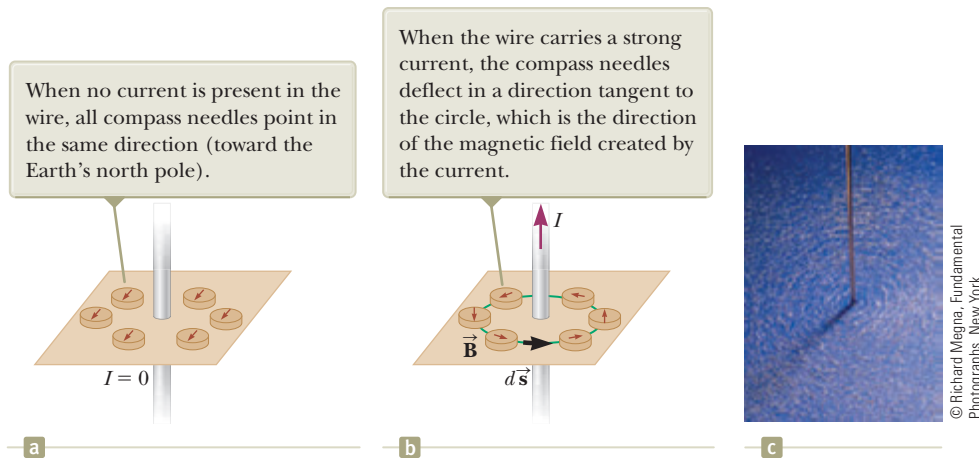

Figure 30.10 (a) and (b) Compasses show the effects of the current in a nearby wire. (c) Circular magnetic field lines surrounding a current-carrying conductor, displayed with iron filings.

over the closed circular path.¹ Along this path, the vectors $d\vec{s}$ and \vec{B} are parallel at each point (see Fig. 30.10b), so $\vec{B} \cdot d\vec{s} = B ds$. Furthermore, the magnitude of \vec{B} is constant on this circle and is given by Equation 30.5. Therefore, the sum of the products $B ds$ over the closed path, which is equivalent to the line integral of $\vec{B} \cdot d\vec{s}$, is

$$\oint \vec{B} \cdot d\vec{s} = B \oint ds = \frac{\mu_0 I}{2\pi r} (2\pi r) = \mu_0 I$$

where $\oint ds = 2\pi r$ is the circumference of the circular path of radius r . Although this result was calculated for the special case of a circular path surrounding a wire of infinite length, it holds for a closed path of *any* shape (an *amperian loop*) surrounding a current that exists in an unbroken circuit. The general case, known as **Ampère's law**, can be stated as follows:

The line integral of $\vec{B} \cdot d\vec{s}$ around any closed path equals $\mu_0 I$, where I is the total steady current passing through any surface bounded by the closed path:

$$\oint \vec{B} \cdot d\vec{s} = \mu_0 I \quad (30.13)$$

Ampère's law describes the creation of magnetic fields by all continuous current configurations, but at our mathematical level it is useful only for calculating the magnetic field of current configurations having a high degree of symmetry. Its use is similar to that of Gauss's law in calculating electric fields for highly symmetric charge distributions.

Quick Quiz 30.3 Rank the magnitudes of $\oint \vec{B} \cdot d\vec{s}$ for the closed paths a through d in Figure 30.11 from greatest to least.

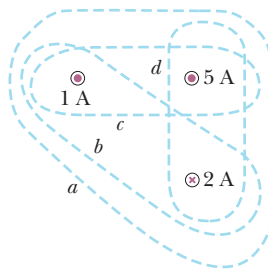

Figure 30.11 (Quick Quiz 30.3) Four closed paths around three current-carrying wires.

¹You may wonder why we would choose to evaluate this scalar product. The origin of Ampère's law is in 19th-century science, in which a "magnetic charge" (the supposed analog to an isolated electric charge) was imagined to be moved around a circular field line. The work done on the charge was related to $\vec{B} \cdot d\vec{s}$, just as the work done moving an electric charge in an electric field is related to $\vec{E} \cdot d\vec{s}$. Therefore, Ampère's law, a valid and useful principle, arose from an erroneous and abandoned work calculation!

Quick Quiz 30.4 Rank the magnitudes of $\oint \vec{B} \cdot d\vec{s}$ for the closed paths *a* through *d* in Figure 30.12 from greatest to least.

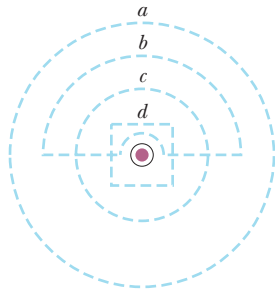

Figure 30.12 (Quick Quiz 30.4) Several closed paths near a single current-carrying wire.

Example 30.5 The Magnetic Field Created by a Long Current-Carrying Wire

A long, straight wire of radius *R* carries a steady current *I* that is uniformly distributed through the cross section of the wire (Fig. 30.13). Calculate the magnetic field a distance *r* from the center of the wire in the regions $r \geq R$ and $r < R$.

SOLUTION

Conceptualize Study Figure 30.13 to understand the structure of the wire and the current in the wire. The current creates magnetic fields everywhere, both inside and outside the wire. Based on our discussions about long, straight wires, we expect the magnetic field lines to be circles centered on the central axis of the wire.

Categorize Because the wire has a high degree of symmetry, we categorize this example as an Ampère's law problem. For the $r \geq R$ case, we should arrive at the same result as was obtained in Example 30.1, where we applied the Biot-Savart law to the same situation.

Analyze For the magnetic field exterior to the wire, let us choose for our path of integration circle 1 in Figure 30.13. From symmetry, \vec{B} must be constant in magnitude and parallel to $d\vec{s}$ at every point on this circle.

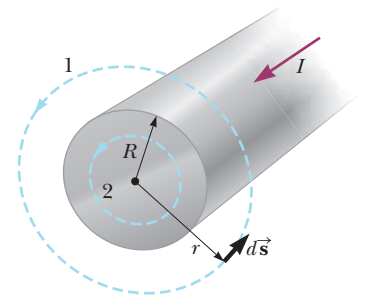

Figure 30.13 (Example 30.5) A long, straight wire of radius *R* carrying a steady current *I* uniformly distributed across the cross section of the wire. The magnetic field at any point can be calculated from Ampère's law using a circular path of radius *r*, concentric with the wire.

Note that the total current passing through the plane of the circle is *I* and apply Ampère's law:

$$\oint \vec{B} \cdot d\vec{s} = B \oint ds = B(2\pi r) = \mu_0 I$$

Solve for *B*:

$$B = \frac{\mu_0 I}{2\pi r} \quad (\text{for } r \geq R) \tag{30.14}$$

Now consider the interior of the wire, where $r < R$. Here the current *I'* passing through the plane of circle 2 is less than the total current *I*.

Set the ratio of the current *I'* enclosed by circle 2 to the entire current *I* equal to the ratio of the area πr^2 enclosed by circle 2 to the cross-sectional area πR^2 of the wire:

$$\frac{I'}{I} = \frac{\pi r^2}{\pi R^2}$$

Solve for *I'*:

$$I' = \frac{r^2}{R^2} I$$

Apply Ampère's law to circle 2:

$$\oint \vec{B} \cdot d\vec{s} = B(2\pi r) = \mu_0 I' = \mu_0 \left(\frac{r^2}{R^2} I \right)$$

Solve for *B*:

$$B = \left(\frac{\mu_0 I}{2\pi R^2} \right) r \quad (\text{for } r < R) \tag{30.15}$$

continued

30.5 continued

Finalize The magnetic field exterior to the wire is identical in form to Equation 30.5. As is often the case in highly symmetric situations, it is much easier to use Ampère's law than the Biot–Savart law (Example 30.1). The magnetic field interior to the wire is similar in form to the expression for the electric field inside a uniformly charged sphere (see Example 24.3). The magnitude of the magnetic field versus r for this configuration is plotted in Figure 30.14. Inside the wire, $B \rightarrow 0$ as $r \rightarrow 0$. Furthermore, Equations 30.14 and 30.15 give the same value of the magnetic field at $r = R$, demonstrating that the magnetic field is continuous at the surface of the wire.

Figure 30.14 (Example 30.5) Magnitude of the magnetic field versus r for the wire shown in Figure 30.13. The field is proportional to r inside the wire and varies as $1/r$ outside the wire.

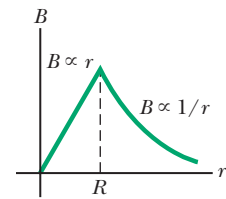

Example 30.6 The Magnetic Field Created by a Toroid

A device called a *toroid* (Fig. 30.15) is often used to create an almost uniform magnetic field in some enclosed area. The device consists of a conducting wire wrapped around a ring (a *torus*) made of a nonconducting material. For a toroid having N closely spaced turns of wire, calculate the magnetic field in the region occupied by the torus, a distance r from the center.

SOLUTION

Conceptualize Study Figure 30.15 carefully to understand how the wire is wrapped around the torus. The torus could be a solid material or it could be air, with a stiff wire wrapped into the shape shown in Figure 30.15 to form an empty toroid. Imagine each turn of the wire to be a circular loop as in Example 30.3. The magnetic field at the center of the loop is perpendicular to the plane of the loop. Therefore, the magnetic field lines of the collection of loops will form circles within the toroid such as suggested by loop 1 in Figure 30.15.

Categorize Because the toroid has a high degree of symmetry, we categorize this example as an Ampère's law problem.

Analyze Consider the circular amperian loop (loop 1) of radius r in the plane of Figure 30.15. By symmetry, the magnitude of the field is constant on this circle and tangent to it, so $\vec{B} \cdot d\vec{s} = B ds$. Furthermore, the wire passes through the loop N times, so the total current through the loop is NI .

Apply Ampère's law to loop 1:

$$\oint \vec{B} \cdot d\vec{s} = B \oint ds = B(2\pi r) = \mu_0 NI$$

Solve for B :

$$B = \frac{\mu_0 NI}{2\pi r} \quad (30.16)$$

Finalize This result shows that B varies as $1/r$ and hence is *nonuniform* in the region occupied by the torus. If, however, r is very large compared with the cross-sectional radius a of the torus, the field is approximately uniform inside the torus.

For an ideal toroid, in which the turns are closely spaced, the external magnetic field is close to zero, but it is not exactly zero. In Figure 30.15, imagine the radius r

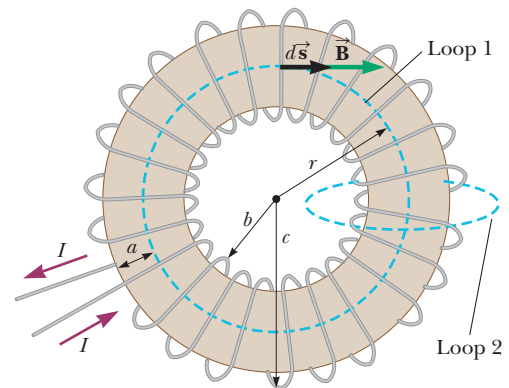

Figure 30.15 (Example 30.6) A toroid consisting of many turns of wire. If the turns are closely spaced, the magnetic field in the interior of the toroid is tangent to the dashed circle (loop 1) and varies as $1/r$. The dimension a is the cross-sectional radius of the torus. The field outside the toroid is very small and can be described by using the amperian loop (loop 2) at the right side, perpendicular to the page.

of amperian loop 1 to be either smaller than b or larger than c . In either case, the loop encloses zero net current, so $\oint \vec{B} \cdot d\vec{s} = 0$. You might think this result proves that $\vec{B} = 0$, but it does not. Consider the amperian loop (loop 2) on the right side of the toroid in Figure 30.15. The plane of this loop is perpendicular to the page, and the toroid passes through the loop. As charges enter the toroid as indicated by the current directions in Figure 30.15,

30.6 continued

they work their way counterclockwise around the toroid. Therefore, there is a counterclockwise current around the toroid, so that a current passes through amperian loop 2! This current is small, but not zero. As a result, the toroid

acts as a current loop and produces a weak external field of the form shown in Figure 30.6. The reason $\oint \vec{B} \cdot d\vec{s} = 0$ for amperian loop 1 of radius $r < b$ or $r > c$ is that the field lines are perpendicular to $d\vec{s}$, not because $\vec{B} = 0$.

30.4 The Magnetic Field of a Solenoid

A **solenoid** is a long wire wound in the form of a helix. With this configuration, a reasonably uniform magnetic field can be produced in the space surrounded by the turns of wire—which we shall call the *interior* of the solenoid—when the solenoid carries a current. When the turns are closely spaced, each can be approximated as a circular loop; the net magnetic field is the vector sum of the fields resulting from all the turns.

Figure 30.16 shows the magnetic field lines surrounding a loosely wound solenoid. The field lines in the interior are nearly parallel to one another, are uniformly distributed, and are close together, indicating that the field in this space is strong and almost uniform.

If the turns are closely spaced and the solenoid is of finite length, the external magnetic field lines are as shown in Figure 30.17a. This field line distribution is similar to that surrounding a bar magnet (Fig. 30.17b). Hence, one end of the solenoid behaves like the north pole of a magnet and the opposite end behaves like the south pole. As the length of the solenoid increases, the interior field becomes more uniform and the exterior field becomes weaker. An *ideal solenoid* is approached when the turns are closely spaced and the length is much greater than the radius of the turns. Figure 30.18 (page 916) shows a longitudinal cross section of part of such a solenoid carrying a current I . In this case, the external field is close to zero and the interior field is uniform over a great volume.

Consider the amperian loop (loop 1) perpendicular to the page in Figure 30.18 (page 916), surrounding the ideal solenoid. This loop encloses a small

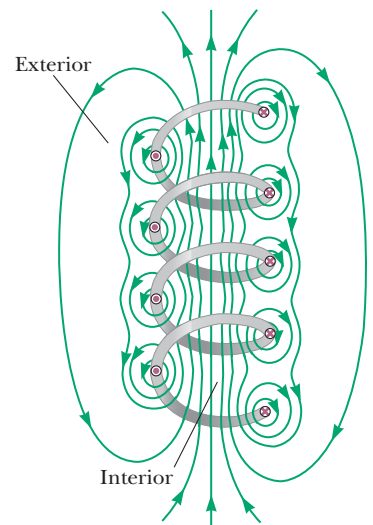

Figure 30.16 The magnetic field lines for a loosely wound solenoid.

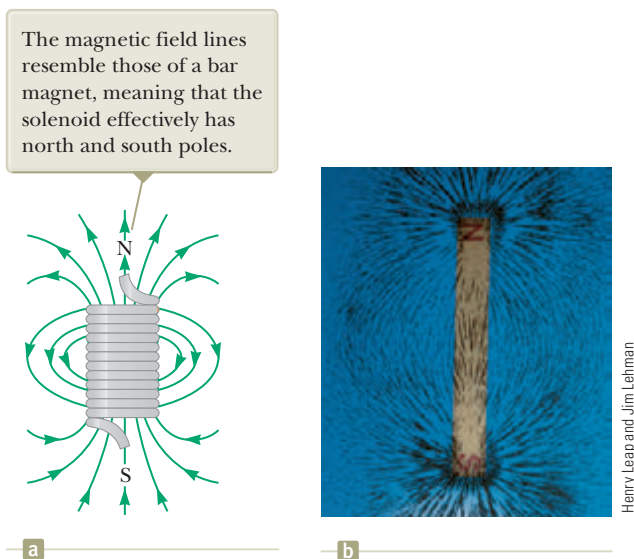

Figure 30.17 (a) Magnetic field lines for a tightly wound solenoid of finite length, carrying a steady current. The field in the interior space is strong and nearly uniform. (b) The magnetic field pattern of a bar magnet, displayed with small iron filings on a sheet of paper.

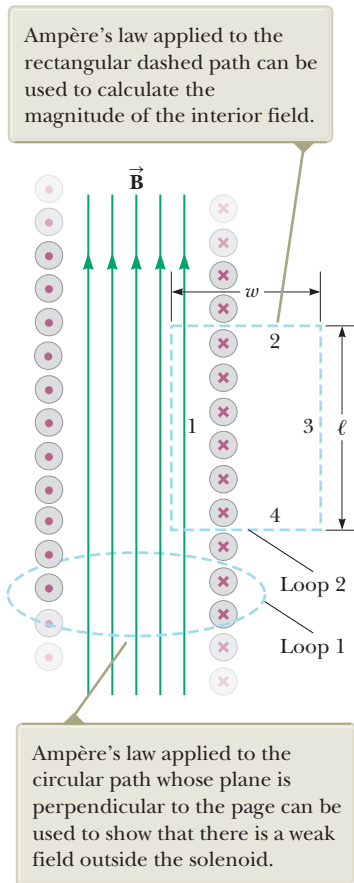

Figure 30.18 Cross-sectional view of an ideal solenoid, where the interior magnetic field is uniform and the exterior field is close to zero.

Magnetic field inside
a solenoid ▶

current as the charges in the wire move coil by coil along the length of the solenoid. Therefore, there is a nonzero magnetic field outside the solenoid. It is a weak field, with circular field lines, like those due to a line of current as in Figure 30.9. For an ideal solenoid, this weak field is the only field external to the solenoid.

We can use Ampère's law to obtain a quantitative expression for the interior magnetic field in an ideal solenoid. Because the solenoid is ideal, \vec{B} in the interior space is uniform and parallel to the axis and the magnetic field lines in the exterior space form circles around the solenoid. The planes of these circles are perpendicular to the page. Consider the rectangular path (loop 2) of length ℓ and width w shown in Figure 30.18. Let's apply Ampère's law to this path by evaluating the integral of $\vec{B} \cdot d\vec{s}$ over each side of the rectangle. The contribution along side 3 is zero because the external magnetic field lines are perpendicular to the path in this region. The contributions from sides 2 and 4 are both zero, again because \vec{B} is perpendicular to $d\vec{s}$ along these paths, both inside and outside the solenoid. Side 1 gives a contribution to the integral because along this path \vec{B} is uniform and parallel to $d\vec{s}$. The integral over the closed rectangular path is therefore

$$\oint \vec{B} \cdot d\vec{s} = \int_{\text{path 1}} \vec{B} \cdot d\vec{s} = B \int ds = B\ell$$

The right side of Ampère's law involves the total current I through the area bounded by the path of integration. In this case, the total current through the rectangular path equals the current through each turn multiplied by the number of turns. If N is the number of turns in the length ℓ , the total current through the rectangle is NI . Therefore, Ampère's law applied to this path gives

$$\oint \vec{B} \cdot d\vec{s} = B\ell = \mu_0 NI$$

$$B = \mu_0 \frac{N}{\ell} I = \mu_0 nI \quad (30.17)$$

where $n = N/\ell$ is the number of turns per unit length.

We also could obtain this result by reconsidering the magnetic field of a toroid (see Example 30.6). If the radius r of the torus in Figure 30.15 containing N turns is much greater than the toroid's cross-sectional radius a , a short section of the toroid approximates a solenoid for which $n = N/2\pi r$. In this limit, Equation 30.16 agrees with Equation 30.17.

Equation 30.17 is valid only for points near the center (that is, far from the ends) of a very long solenoid. As you might expect, the field near each end is smaller than the value given by Equation 30.17. As the length of a solenoid increases, the magnitude of the field at the end approaches half the magnitude at the center (see Problem 69).

- Quick Quiz 30.5** Consider a solenoid that is very long compared with its radius. Of the following choices, what is the most effective way to increase the magnetic field in the interior of the solenoid? (a) double its length, keeping the number of turns per unit length constant (b) reduce its radius by half, keeping the number of turns per unit length constant (c) overlap the entire solenoid with an additional layer of current-carrying wire

30.5 Gauss's Law in Magnetism

The flux associated with a magnetic field is defined in a manner similar to that used to define electric flux (see Eq. 24.3). Consider an element of area dA on an

arbitrarily shaped surface as shown in Figure 30.19. If the magnetic field at this element is \vec{B} , the magnetic flux through the element is $\vec{B} \cdot d\vec{A}$, where $d\vec{A}$ is a vector that is perpendicular to the surface and has a magnitude equal to the area dA . Therefore, the total magnetic flux Φ_B through the surface is

$$\Phi_B \equiv \int \vec{B} \cdot d\vec{A} \tag{30.18}$$

Consider the special case of a plane of area A in a uniform field \vec{B} that makes an angle θ with $d\vec{A}$. The magnetic flux through the plane in this case is

$$\Phi_B = BA \cos \theta \tag{30.19}$$

If the magnetic field is parallel to the plane as in Figure 30.20a, then $\theta = 90^\circ$ and the flux through the plane is zero. If the field is perpendicular to the plane as in Figure 30.20b, then $\theta = 0$ and the flux through the plane is BA (the maximum value).

The unit of magnetic flux is $T \cdot m^2$, which is defined as a *weber* (Wb); $1 \text{ Wb} = 1 \text{ T} \cdot m^2$.

◀ Definition of magnetic flux

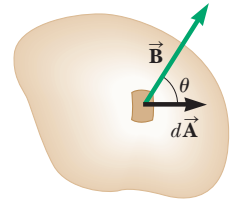

Figure 30.19 The magnetic flux through an area element dA is $\vec{B} \cdot d\vec{A} = B dA \cos \theta$, where $d\vec{A}$ is a vector perpendicular to the surface.

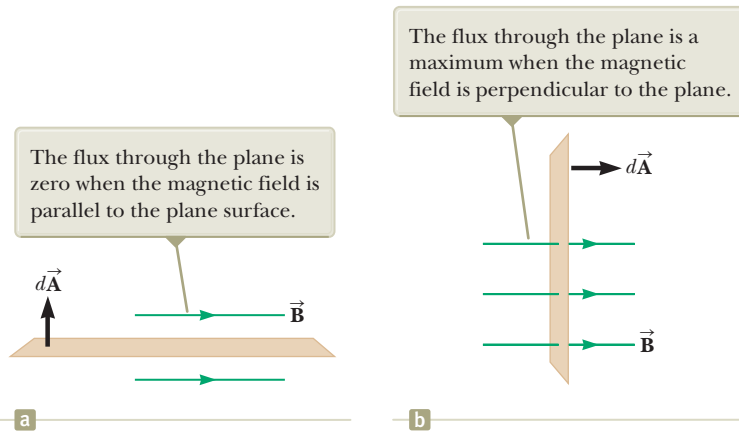

Figure 30.20 Magnetic flux through a plane lying in a magnetic field.

Example 30.7 Magnetic Flux Through a Rectangular Loop

A rectangular loop of width a and length b is located near a long wire carrying a current I (Fig. 30.21). The distance between the wire and the closest side of the loop is c . The wire is parallel to the long side of the loop. Find the total magnetic flux through the loop due to the current in the wire.

SOLUTION

Conceptualize As we saw in Section 30.3, the magnetic field lines due to the wire will be circles, many of which will pass through the rectangular loop. We know that the magnetic field is a function of distance r from a long wire. Therefore, the magnetic field varies over the area of the rectangular loop.

Categorize Because the magnetic field varies over the area of the loop, we must integrate over this area to find the total flux. That identifies this as an analysis problem.

Analyze Noting that \vec{B} is parallel to $d\vec{A}$ at any point within the loop, find the magnetic flux through the rectangular area using Equation 30.18 and incorporate Equation 30.14 for the magnetic field:

Figure 30.21 (Example 30.7) The magnetic field due to the wire carrying a current I is not uniform over the rectangular loop.

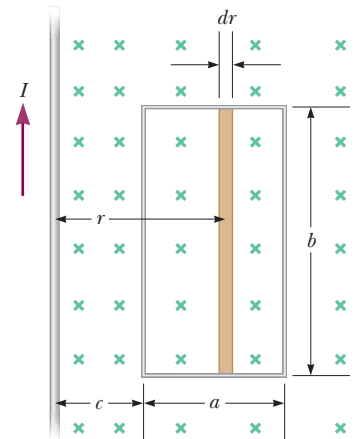

$$\Phi_B = \int \vec{B} \cdot d\vec{A} = \int B dA = \int \frac{\mu_0 I}{2\pi r} dA$$

continued

30.7 continued

Express the area element (the tan strip in Fig. 30.21) as $dA = b dr$ and substitute:

Integrate from $r = c$ to $r = a + c$:

$$\begin{aligned}\Phi_B &= \int \frac{\mu_0 I}{2\pi r} b dr = \frac{\mu_0 I b}{2\pi} \int \frac{dr}{r} \\ \Phi_B &= \frac{\mu_0 I b}{2\pi} \int_c^{a+c} \frac{dr}{r} = \frac{\mu_0 I b}{2\pi} \ln r \Big|_c^{a+c} \\ &= \frac{\mu_0 I b}{2\pi} \ln \left(\frac{a+c}{c} \right) = \frac{\mu_0 I b}{2\pi} \ln \left(1 + \frac{a}{c} \right)\end{aligned}$$

Finalize Notice how the flux depends on the size of the loop. Increasing either a or b increases the flux as expected. If c becomes large such that the loop is very far from the wire, the flux approaches zero, also as expected. If c goes to zero, the flux becomes infinite. In principle, this infinite value occurs because the field becomes infinite at $r = 0$ (assuming an infinitesimally thin wire). That will not happen in reality because the thickness of the wire prevents the left edge of the loop from reaching $r = 0$.

In Chapter 24, we found that the electric flux through a closed surface surrounding a net charge is proportional to that charge (Gauss's law). In other words, the number of electric field lines leaving the surface depends only on the net charge within it. This behavior exists because electric field lines originate and terminate on electric charges.

The situation is quite different for magnetic fields, which are continuous and form closed loops. In other words, as illustrated by the magnetic field lines of a current in Figure 30.9 and of a bar magnet in Figure 30.22, magnetic field lines do not begin or end at any point. For any closed surface such as the one outlined by the dashed line in Figure 30.22, the number of lines entering the surface equals the number leaving the surface; therefore, the net magnetic flux is zero. In contrast, for a closed surface surrounding one charge of an electric dipole (Fig. 30.23), the net electric flux is not zero.

Gauss's law in magnetism states that

the net magnetic flux through any closed surface is always zero:

Gauss's law in magnetism ▶

$$\oint \vec{\mathbf{B}} \cdot d\vec{\mathbf{A}} = 0 \quad (30.20)$$

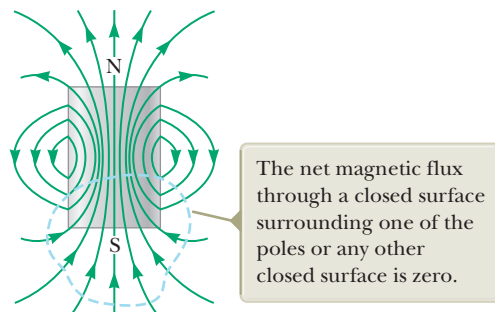

Figure 30.22 The magnetic field lines of a bar magnet form closed loops. (The dashed line represents the intersection of a closed surface with the page.)

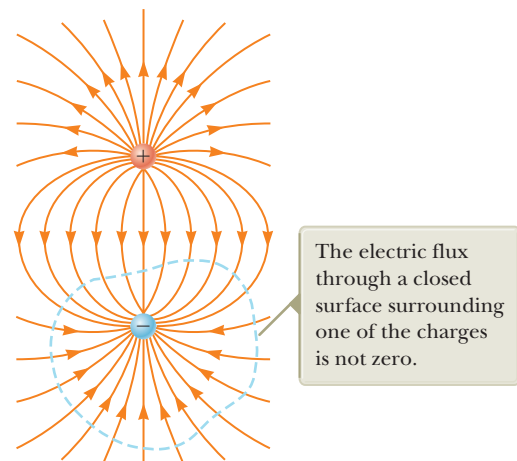

Figure 30.23 The electric field lines surrounding an electric dipole begin on the positive charge and terminate on the negative charge.

This statement represents that isolated magnetic poles (monopoles) have never been detected and perhaps do not exist. Nonetheless, scientists continue the search because certain theories that are otherwise successful in explaining fundamental physical behavior suggest the possible existence of magnetic monopoles.

30.6 Magnetism in Matter

The magnetic field produced by a current in a coil of wire gives us a hint as to what causes certain materials to exhibit strong magnetic properties. Earlier we found that a solenoid like the one shown in Figure 30.17a has a north pole and a south pole. In general, *any* current loop has a magnetic field and therefore has a magnetic dipole moment, including the atomic-level current loops described in some models of the atom.

The Magnetic Moments of Atoms

Let's begin our discussion with a classical model of the atom in which electrons move in circular orbits around the much more massive nucleus. In this model, an orbiting electron constitutes a tiny current loop (because it is a moving charge), and the magnetic moment of the electron is associated with this orbital motion. Although this model has many deficiencies, some of its predictions are in good agreement with the correct theory, which is expressed in terms of quantum physics.

In our classical model, we assume an electron is a particle in uniform circular motion: it moves with constant speed v in a circular orbit of radius r about the nucleus as in Figure 30.24. The current I associated with this orbiting electron is its charge e divided by its period T . Using Equation 4.15 from the particle in uniform circular motion model, $T = 2\pi r/v$, gives

$$I = \frac{e}{T} = \frac{ev}{2\pi r}$$

The magnitude of the magnetic moment associated with this current loop is given by $\mu = IA$, where $A = \pi r^2$ is the area enclosed by the orbit. Therefore,

$$\mu = IA = \left(\frac{ev}{2\pi r}\right)\pi r^2 = \frac{1}{2}evr \quad (30.21)$$

Because the magnitude of the orbital angular momentum of the electron is given by $L = m_e vr$ (Eq. 11.12 with $\phi = 90^\circ$), the magnetic moment can be written as

$$\mu = \left(\frac{e}{2m_e}\right)L \quad (30.22)$$

This result demonstrates that the magnetic moment of the electron is proportional to its orbital angular momentum. Because the electron is negatively charged, the vectors $\vec{\mu}$ and \vec{L} point in *opposite* directions. Both vectors are perpendicular to the plane of the orbit as indicated in Figure 30.24.

A fundamental outcome of quantum physics is that orbital angular momentum is quantized and is equal to multiples of $\hbar = h/2\pi = 1.05 \times 10^{-34} \text{ J} \cdot \text{s}$, where h is Planck's constant (see Chapter 40). The smallest nonzero value of the electron's magnetic moment resulting from its orbital motion is

$$\mu = \sqrt{2} \frac{e}{2m_e} \hbar \quad (30.23)$$

We shall see in Chapter 42 how expressions such as Equation 30.23 arise.

Because all substances contain electrons, you may wonder why most substances are not magnetic. The main reason is that, in most substances, the magnetic

The electron has an angular momentum \vec{L} in one direction and a magnetic moment $\vec{\mu}$ in the opposite direction.

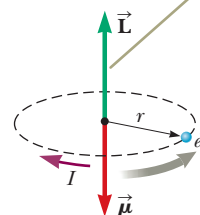

Figure 30.24 An electron moving in the direction of the gray arrow in a circular orbit of radius r . Because the electron carries a negative charge, the direction of the current due to its motion about the nucleus is opposite the direction of that motion.

◀ Orbital magnetic moment

Pitfall Prevention 30.3

The Electron Does Not Spin The electron is *not* physically spinning. It has an intrinsic angular momentum *as if it were spinning*, but the notion of rotation for a point particle is meaningless. Rotation applies only to a *rigid object*, with an extent in space, as in Chapter 10. Spin angular momentum is actually a relativistic effect.

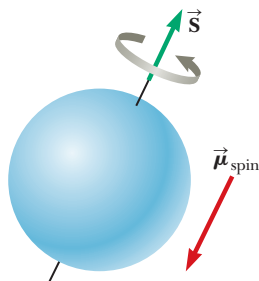

Figure 30.25 Classical model of a spinning electron. We can adopt this model to remind ourselves that electrons have an intrinsic angular momentum. The model should not be pushed too far, however; it gives an incorrect magnitude for the magnetic moment, incorrect quantum numbers, and too many degrees of freedom.

Table 30.1 Magnetic Moments of Some Atoms and Ions

Atom or Ion	Magnetic Moment (10^{-24} J/T)
H	9.27
He	0
Ne	0
Ce ³⁺	19.8
Yb ³⁺	37.1

moment of one electron in an atom is canceled by that of another electron orbiting in the opposite direction. The net result is that, for most materials, the magnetic effect produced by the orbital motion of the electrons is either zero or very small.

In addition to its orbital magnetic moment, an electron (as well as protons, neutrons, and other particles) has an intrinsic property called **spin** that also contributes to its magnetic moment. Classically, the electron might be viewed as spinning about its axis as shown in Figure 30.25, but you should be very careful with the classical interpretation. The magnitude of the angular momentum \vec{S} associated with spin is on the same order of magnitude as the magnitude of the angular momentum \vec{L} due to the orbital motion. The magnitude of the spin angular momentum of an electron predicted by quantum theory is

$$S = \frac{\sqrt{3}}{2} \hbar$$

The magnetic moment characteristically associated with the spin of an electron has the value

$$\mu_{\text{spin}} = \frac{e\hbar}{2m_e} \quad (30.24)$$

This combination of constants is called the **Bohr magneton** μ_B :

$$\mu_B = \frac{e\hbar}{2m_e} = 9.27 \times 10^{-24} \text{ J/T} \quad (30.25)$$

Therefore, atomic magnetic moments can be expressed as multiples of the Bohr magneton. (Note that $1 \text{ J/T} = 1 \text{ A} \cdot \text{m}^2$.)

In atoms containing many electrons, the electrons usually pair up with their spins opposite each other; therefore, the spin magnetic moments cancel. Atoms containing an odd number of electrons, however, must have at least one unpaired electron and therefore some spin magnetic moment. The total magnetic moment of an atom is the vector sum of the orbital and spin magnetic moments, and a few examples are given in Table 30.1. Notice that helium and neon have zero moments because their individual spin and orbital moments cancel.

The nucleus of an atom also has a magnetic moment associated with its constituent protons and neutrons. The magnetic moment of a proton or neutron, however, is much smaller than that of an electron and can usually be neglected. We can understand this smaller value by inspecting Equation 30.25 and replacing the mass of the electron with the mass of a proton or a neutron. Because the masses of the proton and neutron are much greater than that of the electron, their magnetic moments are on the order of 10^3 times smaller than that of the electron.

Ferromagnetism

A small number of crystalline substances exhibit strong magnetic effects called **ferromagnetism**. Some examples of ferromagnetic substances are iron, cobalt, nickel, gadolinium, and dysprosium. These substances contain permanent atomic magnetic moments that tend to align parallel to each other even in a weak external magnetic field. Once the moments are aligned, the substance remains magnetized after the external field is removed. This permanent alignment is due to a strong coupling between neighboring moments, a coupling that can be understood only in quantum-mechanical terms.

All ferromagnetic materials are made up of microscopic regions called **domains**, regions within which all magnetic moments are aligned. These domains have volumes of about 10^{-12} to 10^{-8} m^3 and contain 10^{17} to 10^{21} atoms. The boundaries between the various domains having different orientations are called **domain walls**. In an unmagnetized sample, the magnetic moments in the domains are randomly

oriented so that the net magnetic moment is zero as in Figure 30.26a. When the sample is placed in an external magnetic field \vec{B} , the size of those domains with magnetic moments aligned with the field grows, which results in a magnetized sample as in Figure 30.26b. As the external field becomes very strong as in Figure 30.26c, the domains in which the magnetic moments are not aligned with the field become very small. When the external field is removed, the sample may retain a net magnetization in the direction of the original field. At ordinary temperatures, thermal agitation is not sufficient to disrupt this preferred orientation of magnetic moments.

When the temperature of a ferromagnetic substance reaches or exceeds a critical temperature called the **Curie temperature**, the substance loses its residual magnetization. Below the Curie temperature, the magnetic moments are aligned and the substance is ferromagnetic. Above the Curie temperature, the thermal agitation is great enough to cause a random orientation of the moments and the substance becomes paramagnetic. Curie temperatures for several ferromagnetic substances are given in Table 30.2.

Paramagnetism

Paramagnetic substances have a weak magnetism resulting from the presence of atoms (or ions) that have permanent magnetic moments. These moments interact only weakly with one another and are randomly oriented in the absence of an external magnetic field. When a paramagnetic substance is placed in an external magnetic field, its atomic moments tend to line up with the field. This alignment process, however, must compete with thermal motion, which tends to randomize the magnetic moment orientations.

Diamagnetism

When an external magnetic field is applied to a diamagnetic substance, a weak magnetic moment is induced in the direction opposite the applied field, causing diamagnetic substances to be weakly repelled by a magnet. Although diamagnetism is present in all matter, its effects are much smaller than those of paramagnetism or ferromagnetism and are evident only when those other effects do not exist.

We can attain some understanding of diamagnetism by considering a classical model of two atomic electrons orbiting the nucleus in opposite directions but with the same speed. The electrons remain in their circular orbits because of the attractive electrostatic force exerted by the positively charged nucleus. Because the magnetic moments of the two electrons are equal in magnitude and opposite in direction, they cancel each other and the magnetic moment of the atom is zero. When an external magnetic field is applied, the electrons experience an additional magnetic force $q\vec{v} \times \vec{B}$. This added magnetic force combines with the electrostatic force to increase the orbital speed of the electron whose magnetic moment is antiparallel to the field and to decrease the speed of the electron whose magnetic moment is parallel to the field. As a result, the two magnetic moments of the electrons no longer cancel and the substance acquires a net magnetic moment that is opposite the applied field.

Table 30.2 Curie Temperatures for Several Ferromagnetic Substances

Substance	T_{Curie} (K)
Iron	1 043
Cobalt	1 394
Nickel	631
Gadolinium	317
Fe_2O_3	893

In an unmagnetized substance, the atomic magnetic dipoles are randomly oriented.

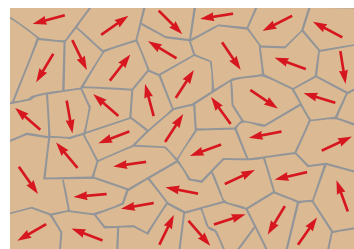

a

When an external field \vec{B} is applied, the domains with components of magnetic moment in the same direction as \vec{B} grow larger, giving the sample a net magnetization.

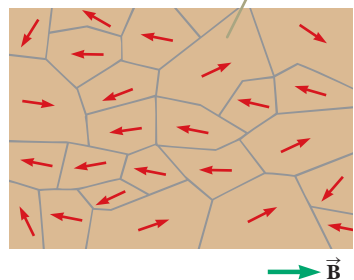

b

As the field is made even stronger, the domains with magnetic moment vectors not aligned with the external field become very small.

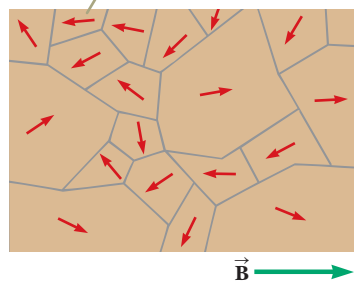

c

Figure 30.26 Orientation of magnetic dipoles before and after a magnetic field is applied to a ferromagnetic substance.

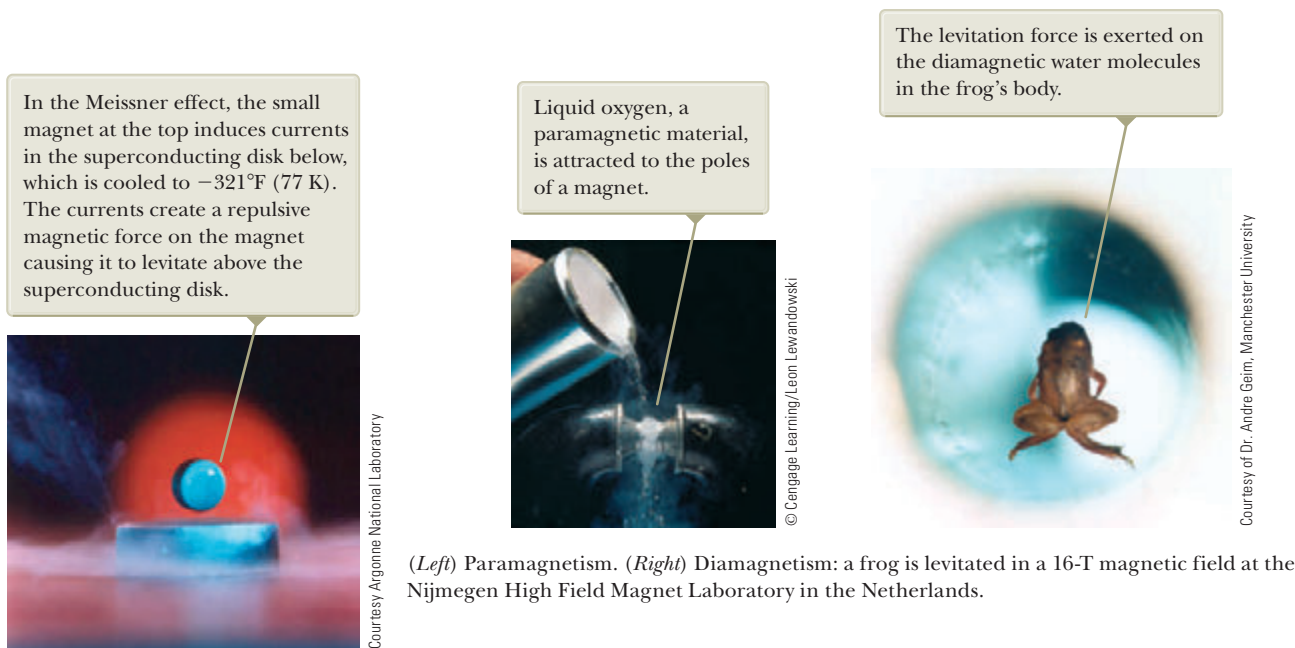

Figure 30.27 An illustration of the Meissner effect, shown by this magnet suspended above a cooled ceramic superconductor disk, has become our most visual image of high-temperature superconductivity. Superconductivity is the loss of all resistance to electrical current and is a key to more-efficient energy use.

As you recall from Chapter 27, a superconductor is a substance in which the electrical resistance is zero below some critical temperature. Certain types of superconductors also exhibit perfect diamagnetism in the superconducting state. As a result, an applied magnetic field is expelled by the superconductor so that the field is zero in its interior. This phenomenon is known as the **Meissner effect**. If a permanent magnet is brought near a superconductor, the two objects repel each other. This repulsion is illustrated in Figure 30.27, which shows a small permanent magnet levitated above a superconductor maintained at 77 K .

Summary

Definition

The **magnetic flux** Φ_B through a surface is defined by the surface integral

$$\Phi_B \equiv \int \vec{\mathbf{B}} \cdot d\vec{\mathbf{A}} \quad (30.18)$$

Concepts and Principles

The **Biot–Savart law** says that the magnetic field $d\vec{\mathbf{B}}$ at a point P due to a length element $d\vec{\mathbf{s}}$ that carries a steady current I is

$$d\vec{\mathbf{B}} = \frac{\mu_0}{4\pi} \frac{I d\vec{\mathbf{s}} \times \hat{\mathbf{r}}}{r^2} \quad (30.1)$$

where μ_0 is the **permeability of free space**, r is the distance from the element to the point P , and $\hat{\mathbf{r}}$ is a unit vector pointing from $d\vec{\mathbf{s}}$ toward point P . We find the total field at P by integrating this expression over the entire current distribution.

The magnetic force per unit length between two parallel wires separated by a distance a and carrying currents I_1 and I_2 has a magnitude

$$\frac{F_B}{\ell} = \frac{\mu_0 I_1 I_2}{2\pi a} \quad (30.12)$$

The force is attractive if the currents are in the same direction and repulsive if they are in opposite directions.

■ **Ampère's law** says that the line integral of $\vec{B} \cdot d\vec{s}$ around any closed path equals $\mu_0 I$, where I is the total steady current through any surface bounded by the closed path:

$$\oint \vec{B} \cdot d\vec{s} = \mu_0 I \quad (30.13)$$

■ **Gauss's law of magnetism** states that the net magnetic flux through any closed surface is zero:

$$\oint \vec{B} \cdot d\vec{A} = 0 \quad (30.20)$$

■ The magnitude of the magnetic field at a distance r from a long, straight wire carrying an electric current I is

$$B = \frac{\mu_0 I}{2\pi r} \quad (30.14)$$

The field lines are circles concentric with the wire.

The magnitudes of the fields inside a toroid and solenoid are

$$B = \frac{\mu_0 N I}{2\pi r} \quad (\text{toroid}) \quad (30.16)$$

$$B = \mu_0 \frac{N}{\ell} I = \mu_0 n I \quad (\text{solenoid}) \quad (30.17)$$

where N is the total number of turns.

■ Substances can be classified into one of three categories that describe their magnetic behavior. **Diamagnetic** substances are those in which the magnetic moment is weak and opposite the applied magnetic field. **Paramagnetic** substances are those in which the magnetic moment is weak and in the same direction as the applied magnetic field. In **ferromagnetic** substances, interactions between atoms cause magnetic moments to align and create a strong magnetization that remains after the external field is removed.

Objective Questions

1. denotes answer available in *Student Solutions Manual/Study Guide*

- (i) What happens to the magnitude of the magnetic field inside a long solenoid if the current is doubled? (a) It becomes four times larger. (b) It becomes twice as large. (c) It is unchanged. (d) It becomes one-half as large. (e) It becomes one-fourth as large. (ii) What happens to the field if instead the length of the solenoid is doubled, with the number of turns remaining the same? Choose from the same possibilities as in part (i). (iii) What happens to the field if the number of turns is doubled, with the length remaining the same? Choose from the same possibilities as in part (i). (iv) What happens to the field if the radius is doubled? Choose from the same possibilities as in part (i).
- In Figure 30.7, assume $I_1 = 2.00$ A and $I_2 = 6.00$ A. What is the relationship between the magnitude F_1 of the force exerted on wire 1 and the magnitude F_2 of the force exerted on wire 2? (a) $F_1 = 6F_2$ (b) $F_1 = 3F_2$ (c) $F_1 = F_2$ (d) $F_1 = \frac{1}{3}F_2$ (e) $F_1 = \frac{1}{6}F_2$
- Answer each question yes or no. (a) Is it possible for each of three stationary charged particles to exert a force of attraction on the other two? (b) Is it possible for each of three stationary charged particles to repel both of the other particles? (c) Is it possible for each of three current-carrying metal wires to attract the other two wires? (d) Is it possible for each of three current-carrying metal wires to repel the other two wires? André-Marie Ampère's experiments on electromagnetism are models of logical precision and included observation of the phenomena referred to in this question.
- Two long, parallel wires each carry the same current I in the same direction (Fig. OQ30.4). Is the total magnetic

field at the point P midway between the wires (a) zero, (b) directed into the page, (c) directed out of the page, (d) directed to the left, or (e) directed to the right?

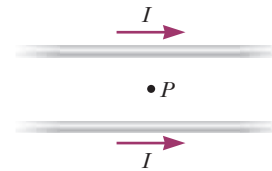

Figure OQ30.4

- Two long, straight wires cross each other at a right angle, and each carries the same current I (Fig. OQ30.5). Which of the following statements is true regarding the total magnetic field due to the two wires at the various points in the figure? More than one statement may be correct. (a) The field is strongest at points B and D . (b) The field is strongest at points A and C . (c) The field is out of the page at point B and

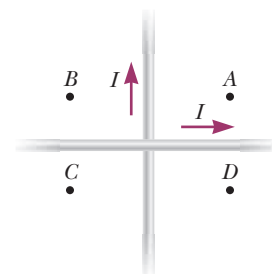

Figure OQ30.5

into the page at point D . (d) The field is out of the page at point C and out of the page at point D . (e) The field has the same magnitude at all four points.

6. A long, vertical, metallic wire carries downward electric current. (i) What is the direction of the magnetic field it creates at a point 2 cm horizontally east of the center of the wire? (a) north (b) south (c) east (d) west (e) up (ii) What would be the direction of the field if the current consisted of positive charges moving downward instead of electrons moving upward? Choose from the same possibilities as in part (i).
7. Suppose you are facing a tall makeup mirror on a vertical wall. Fluorescent tubes framing the mirror carry a clockwise electric current. (i) What is the direction of the magnetic field created by that current at the center of the mirror? (a) left (b) right (c) horizontally toward you (d) horizontally away from you (e) no direction because the field has zero magnitude (ii) What is the direction of the field the current creates at a point on the wall outside the frame to the right? Choose from the same possibilities as in part (i).
8. A long, straight wire carries a current I (Fig. OQ30.8). Which of the following statements is true regarding the magnetic field due to the wire? More than one statement may be correct. (a) The magnitude is proportional to I/r , and the direction is out of the page at P . (b) The magnitude is proportional to I/r^2 , and the direction is out of the page at P . (c) The magnitude is proportional to I/r , and the direction is into the page at P . (d) The magnitude is proportional to I/r^2 , and the direction is into the page at P . (e) The magnitude is proportional to I , but does not depend on r .

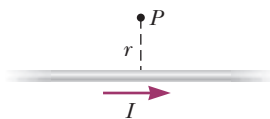

Figure OQ30.8

9. Two long, parallel wires carry currents of 20.0 A and 10.0 A in opposite directions (Fig. OQ30.9). Which of the following statements is true? More than one state-

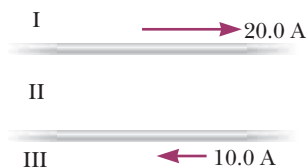

Figure OQ30.9 Objective Questions 9 and 10.

ment may be correct. (a) In region I, the magnetic field is into the page and is never zero. (b) In region II, the field is into the page and can be zero. (c) In region III, it is possible for the field to be zero. (d) In region I, the magnetic field is out of the page and is never zero. (e) There are no points where the field is zero.

10. Consider the two parallel wires carrying currents in opposite directions in Figure OQ30.9. Due to the magnetic interaction between the wires, does the lower wire experience a magnetic force that is (a) upward, (b) downward, (c) to the left, (d) to the right, or (e) into the paper?
11. What creates a magnetic field? More than one answer may be correct. (a) a stationary object with electric charge (b) a moving object with electric charge (c) a stationary conductor carrying electric current (d) a difference in electric potential (e) a charged capacitor disconnected from a battery and at rest *Note:* In Chapter 34, we will see that a changing electric field also creates a magnetic field.
12. A long solenoid with closely spaced turns carries electric current. Does each turn of wire exert (a) an attractive force on the next adjacent turn, (b) a repulsive force on the next adjacent turn, (c) zero force on the next adjacent turn, or (d) either an attractive or a repulsive force on the next turn, depending on the direction of current in the solenoid?
13. A uniform magnetic field is directed along the x axis. For what orientation of a flat, rectangular coil is the flux through the rectangle a maximum? (a) It is a maximum in the xy plane. (b) It is a maximum in the xz plane. (c) It is a maximum in the yz plane. (d) The flux has the same nonzero value for all these orientations. (e) The flux is zero in all cases.
14. Rank the magnitudes of the following magnetic fields from largest to smallest, noting any cases of equality. (a) the field 2 cm away from a long, straight wire carrying a current of 3 A (b) the field at the center of a flat, compact, circular coil, 2 cm in radius, with 10 turns, carrying a current of 0.3 A (c) the field at the center of a solenoid 2 cm in radius and 200 cm long, with 1 000 turns, carrying a current of 0.3 A (d) the field at the center of a long, straight, metal bar, 2 cm in radius, carrying a current of 300 A (e) a field of 1 mT
15. Solenoid A has length L and N turns, solenoid B has length $2L$ and N turns, and solenoid C has length $L/2$ and $2N$ turns. If each solenoid carries the same current, rank the magnitudes of the magnetic fields in the centers of the solenoids from largest to smallest.

Conceptual Questions

I. denotes answer available in *Student Solutions Manual/Study Guide*

- Is the magnetic field created by a current loop uniform? Explain.
- One pole of a magnet attracts a nail. Will the other pole of the magnet attract the nail? Explain. Also explain how a magnet sticks to a refrigerator door.
- Compare Ampère's law with the Biot-Savart law. Which is more generally useful for calculating \vec{B} for a current-carrying conductor?
- A hollow copper tube carries a current along its length. Why is $B = 0$ inside the tube? Is B nonzero outside the tube?

- Imagine you have a compass whose needle can rotate vertically as well as horizontally. Which way would the compass needle point if you were at the Earth's north magnetic pole?
- Is Ampère's law valid for all closed paths surrounding a conductor? Why is it not useful for calculating \vec{B} for all such paths?
- A magnet attracts a piece of iron. The iron can then attract another piece of iron. On the basis of domain alignment, explain what happens in each piece of iron.
- Why does hitting a magnet with a hammer cause the magnetism to be reduced?
- The quantity $\int \vec{B} \cdot d\vec{s}$ in Ampère's law is called *magnetic circulation*. Figures 30.10 and 30.13 show paths around which the magnetic circulation is evaluated. Each of these paths encloses an area. What is the magnetic flux through each area? Explain your answer.
- Figure CQ30.10 shows four permanent magnets, each having a hole through its center. Notice that the blue and yellow magnets are levitated above the red ones. (a) How does this levitation occur? (b) What purpose do the rods serve? (c) What can you say about the poles of the magnets from this observation? (d) If the blue magnet were inverted, what do you suppose would happen?
- Explain why two parallel wires carrying currents in opposite directions repel each other.
- Consider a magnetic field that is uniform in direction throughout a certain volume. (a) Can the field be uniform in magnitude? (b) Must it be uniform in magnitude? Give evidence for your answers.



© Cengage Learning/Charles D. Winters

Figure CQ30.10

Problems



The problems found in this chapter may be assigned online in Enhanced WebAssign

- straightforward; 2. intermediate; 3. challenging

- full solution available in the *Student Solutions Manual/Study Guide*

AMT Analysis Model tutorial available in Enhanced WebAssign

GP Guided Problem

M Master It tutorial available in Enhanced WebAssign

W Watch It video solution available in Enhanced WebAssign

Section 30.1 The Biot–Savart Law

- Review.** In studies of the possibility of migrating birds using the Earth's magnetic field for navigation, birds have been fitted with coils as “caps” and “collars” as shown in Figure P30.1. (a) If the identical coils have radii of 1.20 cm and are 2.20 cm apart, with 50 turns of wire apiece, what current should they both carry to produce a magnetic field of 4.50×10^{-5} T halfway between them? (b) If the resistance of each coil is 210Ω , what voltage should the battery supplying each coil have? (c) What power is delivered to each coil?

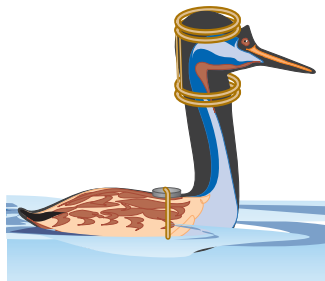

Figure P30.1

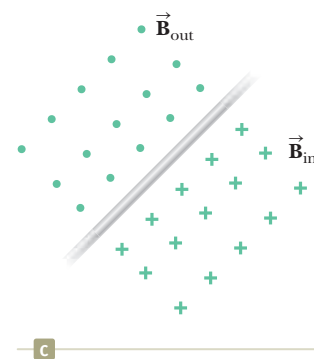
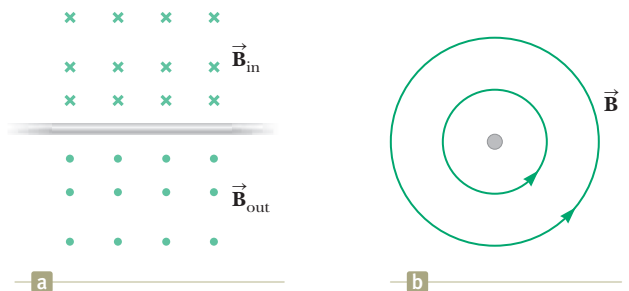

Figure P30.2

- In each of parts (a) through (c) of Figure P30.2, find the direction of the current in the wire that would produce a magnetic field directed as shown.
- Calculate the magnitude of the magnetic field at a **W** point 25.0 cm from a long, thin conductor carrying a current of 2.00 A.

4. In 1962, measurements of the magnetic field of a large tornado were made at the Geophysical Observatory in Tulsa, Oklahoma. If the magnitude of the tornado's field was $B = 1.50 \times 10^{-8} \text{ T}$ pointing north when the tornado was 9.00 km east of the observatory, what current was carried up or down the funnel of the tornado? Model the vortex as a long, straight wire carrying a current.

5. (a) A conducting loop in the shape of a square of edge length $\ell = 0.400 \text{ m}$ carries a current $I = 10.0 \text{ A}$ as shown in Figure P30.5. Calculate the magnitude and direction of the magnetic field at the center of the square. (b) **What If?** If this conductor is reshaped to form a circular loop and carries the same current, what is the value of the magnetic field at the center?

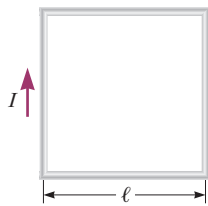

Figure P30.5

6. In Niels Bohr's 1913 model of the hydrogen atom, an electron circles the proton at a distance of $5.29 \times 10^{-11} \text{ m}$ with a speed of $2.19 \times 10^6 \text{ m/s}$. Compute the magnitude of the magnetic field this motion produces at the location of the proton.
7. A conductor consists of a circular loop of radius $R = 15.0 \text{ cm}$ and two long, straight sections as shown in Figure P30.7. The wire lies in the plane of the paper and carries a current $I = 1.00 \text{ A}$. Find the magnetic field at the center of the loop.

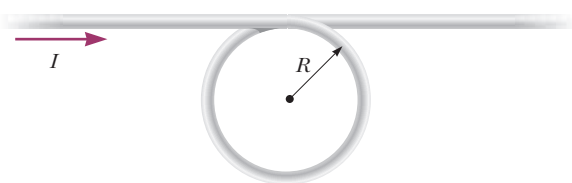

Figure P30.7 Problems 7 and 8.

8. A conductor consists of a circular loop of radius R and two long, straight sections as shown in Figure P30.7. The wire lies in the plane of the paper and carries a current I . (a) What is the direction of the magnetic field at the center of the loop? (b) Find an expression for the magnitude of the magnetic field at the center of the loop.
9. Two long, straight, parallel wires carry currents that are directed perpendicular to the page as shown in Figure P30.9. Wire 1 carries a current I_1 into the page (in the negative z direction) and passes through the x axis at $x = +a$. Wire 2 passes through the x axis at $x = -2a$ and carries an unknown cur-

rent I_2 . The total magnetic field at the origin due to the current-carrying wires has the magnitude $2\mu_0 I_1 / (2\pi a)$. The current I_2 can have either of two possible values. (a) Find the value of I_2 with the smaller magnitude, stating it in terms of I_1 and giving its direction. (b) Find the other possible value of I_2 .

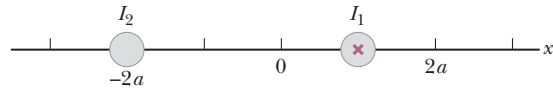

Figure P30.9

10. An infinitely long wire carrying a current I is bent at a right angle as shown in Figure P30.10. Determine the magnetic field at point P , located a distance x from the corner of the wire.

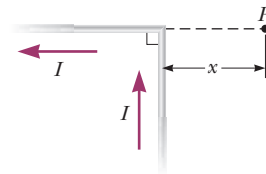

Figure P30.10

11. A long, straight wire carries a current I . A right-angle bend is made in the middle of the wire. The bend forms an arc of a circle of radius r as shown in Figure P30.11. Determine the magnetic field at point P , the center of the arc.

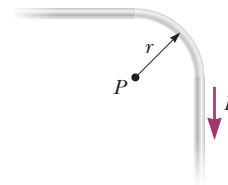

Figure P30.11

12. Consider a flat, circular current loop of radius R carrying a current I . Choose the x axis to be along the axis of the loop, with the origin at the loop's center. Plot a graph of the ratio of the magnitude of the magnetic field at coordinate x to that at the origin for $x = 0$ to $x = 5R$. It may be helpful to use a programmable calculator or a computer to solve this problem.
13. A current path shaped as shown in Figure P30.13 produces a magnetic field at P , the center of the arc. If the arc subtends an angle of $\theta = 30.0^\circ$ and the radius of the arc is 0.600 m, what are the magnitude and

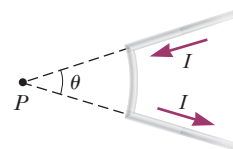

Figure P30.13

direction of the field produced at P if the current is 3.00 A?

- 14.** One long wire carries current 30.0 A to the left along the x axis. A second long wire carries current 50.0 A to the right along the line ($y = 0.280$ m, $z = 0$). (a) Where in the plane of the two wires is the total magnetic field equal to zero? (b) A particle with a charge of $-2.00 \mu\text{C}$ is moving with a velocity of $150\hat{i}$ Mm/s along the line ($y = 0.100$ m, $z = 0$). Calculate the vector magnetic force acting on the particle. (c) **What If?** A uniform electric field is applied to allow this particle to pass through this region undeflected. Calculate the required vector electric field.

- 15.** Three long, parallel conductors each carry a current of $I = 2.00$ A. Figure P30.15 is an end view of the conductors, with each current coming out of the page. Taking $a = 1.00$ cm, determine the magnitude and direction of the magnetic field at (a) point A, (b) point B, and (c) point C.

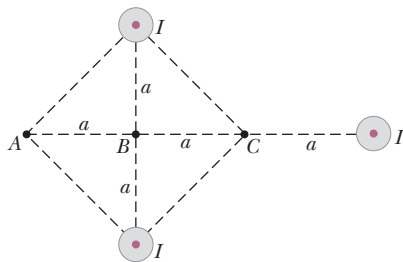

Figure P30.15

- 16.** In a long, straight, vertical lightning stroke, electrons move downward and positive ions move upward and constitute a current of magnitude 20.0 kA. At a location 50.0 m east of the middle of the stroke, a free electron drifts through the air toward the west with a speed of 300 m/s. (a) Make a sketch showing the various vectors involved. Ignore the effect of the Earth's magnetic field. (b) Find the vector force the lightning stroke exerts on the electron. (c) Find the radius of the electron's path. (d) Is it a good approximation to model the electron as moving in a uniform field? Explain your answer. (e) If it does not collide with any obstacles, how many revolutions will the electron complete during the 60.0- μs duration of the lightning stroke?
- 17.** Determine the magnetic field (in terms of I , a , and d) at the origin due to the current loop in Figure P30.17. The loop extends to infinity above the figure.

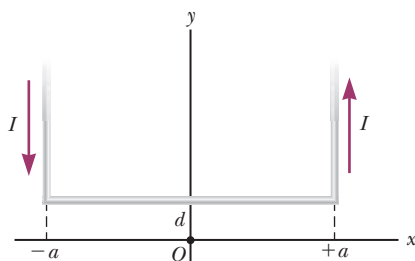

Figure P30.17

- 18.** A wire carrying a current I is bent into the shape of an equilateral triangle of side L . (a) Find the magnitude of the magnetic field at the center of the triangle. (b) At a point halfway between the center and any vertex, is the field stronger or weaker than at the center? Give a qualitative argument for your answer.

- 19.** The two wires shown in Figure P30.19 are separated by $d = 10.0$ cm and carry currents of $I = 5.00$ A in opposite directions. Find the magnitude and direction of the net magnetic field (a) at a point midway between the wires; (b) at point P_1 , 10.0 cm to the right of the wire on the right; and (c) at point P_2 , $2d = 20.0$ cm to the left of the wire on the left.

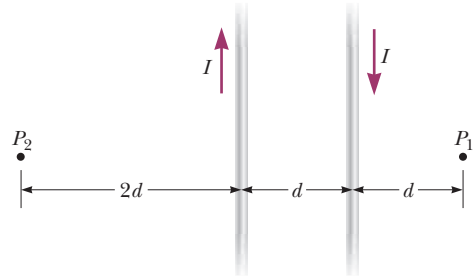

Figure P30.19

- 20.** Two long, parallel wires carry currents of $I_1 = 3.00$ A and $I_2 = 5.00$ A in the directions indicated in Figure P30.20. (a) Find the magnitude and direction of the magnetic field at a point midway between the wires. (b) Find the magnitude and direction of the magnetic field at point P , located $d = 20.0$ cm above the wire carrying the 5.00-A current.

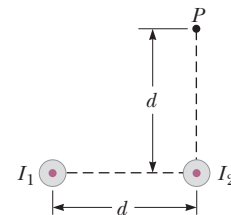

Figure P30.20

Section 30.2 The Magnetic Force Between Two Parallel Conductors

- 21.** Two long, parallel conductors, separated by 10.0 cm, carry currents in the same direction. The first wire carries a current $I_1 = 5.00$ A, and the second carries $I_2 = 8.00$ A. (a) What is the magnitude of the magnetic field created by I_1 at the location of I_2 ? (b) What is the force per unit length exerted by I_1 on I_2 ? (c) What is the magnitude of the magnetic field created by I_2 at the location of I_1 ? (d) What is the force per length exerted by I_2 on I_1 ?
- 22.** Two parallel wires separated by 4.00 cm repel each other with a force per unit length of 2.00×10^{-4} N/m. The current in one wire is 5.00 A. (a) Find the current in the other wire. (b) Are the currents in the same

direction or in opposite directions? (c) What would happen if the direction of one current were reversed and doubled?

23. Two parallel wires are separated by 6.00 cm, each carrying 3.00 A of current in the same direction. (a) What is the magnitude of the force per unit length between the wires? (b) Is the force attractive or repulsive?
24. Two long wires hang vertically. Wire 1 carries an upward current of 1.50 A. Wire 2, 20.0 cm to the right of wire 1, carries a downward current of 4.00 A. A third wire, wire 3, is to be hung vertically and located such that when it carries a certain current, each wire experiences no net force. (a) Is this situation possible? Is it possible in more than one way? Describe (b) the position of wire 3 and (c) the magnitude and direction of the current in wire 3.

25. In Figure P30.25, the current in the long, straight wire is $I_1 = 5.00$ A and the wire lies in the plane of the rectangular loop, which carries a current $I_2 = 10.0$ A. The dimensions in the figure are $c = 0.100$ m, $a = 0.150$ m, and $\ell = 0.450$ m. Find the magnitude and direction of the net force exerted on the loop by the magnetic field created by the wire.

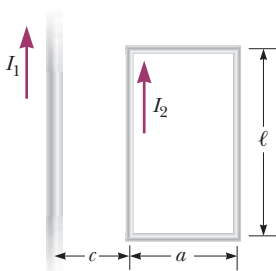

Figure P30.25 Problems 25 and 26.

26. In Figure P30.25, the current in the long, straight wire is I_1 and the wire lies in the plane of a rectangular loop, which carries a current I_2 . The loop is of length ℓ and width a . Its left end is a distance c from the wire. Find the magnitude and direction of the net force exerted on the loop by the magnetic field created by the wire.
27. Two long, parallel wires are attracted to each other by a force per unit length of $320 \mu\text{N/m}$. One wire carries a current of 20.0 A to the right and is located along the line $y = 0.500$ m. The second wire lies along the x axis. Determine the value of y for the line in the plane of the two wires along which the total magnetic field is zero.
28. Why is the following situation impossible? Two parallel copper conductors each have length $\ell = 0.500$ m and radius $r = 250 \mu\text{m}$. They carry currents $I = 10.0$ A in opposite directions and repel each other with a magnetic force $F_B = 1.00$ N.
29. The unit of magnetic flux is named for Wilhelm Weber. A practical-size unit of magnetic field is named for Johann Karl Friedrich Gauss. Along with their indi-

vidual accomplishments, Weber and Gauss built a telegraph in 1833 that consisted of a battery and switch, at one end of a transmission line 3 km long, operating an electromagnet at the other end. Suppose their transmission line was as diagrammed in Figure P30.29. Two long, parallel wires, each having a mass per unit length of 40.0 g/m, are supported in a horizontal plane by strings $\ell = 6.00$ cm long. When both wires carry the same current I , the wires repel each other so that the angle between the supporting strings is $\theta = 16.0^\circ$. (a) Are the currents in the same direction or in opposite directions? (b) Find the magnitude of the current. (c) If this transmission line were taken to Mars, would the current required to separate the wires by the same angle be larger or smaller than that required on the Earth? Why?

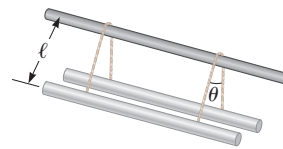

Figure P30.29

Section 30.3 Ampère's Law

30. Niobium metal becomes a superconductor when cooled below 9 K. Its superconductivity is destroyed when the surface magnetic field exceeds 0.100 T. In the absence of any external magnetic field, determine the maximum current a 2.00-mm-diameter niobium wire can carry and remain superconducting.

31. Figure P30.31 is a cross-sectional view of a coaxial cable. The center conductor is surrounded by a rubber layer, an outer conductor, and another rubber layer. In a particular application, the current in the inner conductor is $I_1 = 1.00$ A out of the page and the current in the outer conductor is $I_2 = 3.00$ A into the page. Assuming the distance $d = 1.00$ mm, determine the magnitude and direction of the magnetic field at (a) point a and (b) point b .

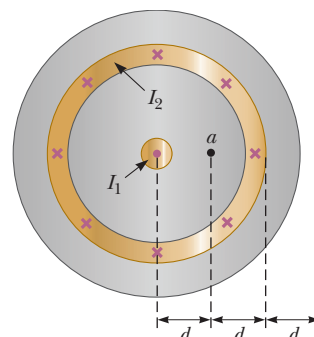

Figure P30.31

32. The magnetic coils of a tokamak fusion reactor are in the shape of a toroid having an inner radius of 0.700 m and an outer radius of 1.30 m. The toroid has 900 turns of large-diameter wire, each of which carries a current of 14.0 kA. Find the magnitude of the mag-

netic field inside the toroid along (a) the inner radius and (b) the outer radius.

33. A long, straight wire lies on a horizontal table and carries a current of $1.20 \mu\text{A}$. In a vacuum, a proton moves parallel to the wire (opposite the current) with a constant speed of $2.30 \times 10^4 \text{ m/s}$ at a distance d above the wire. Ignoring the magnetic field due to the Earth, determine the value of d .
34. An infinite sheet of current lying in the yz plane carries a surface current of linear density J_s . The current is in the positive z direction, and J_s represents the current per unit length measured along the y axis. Figure P30.34 is an edge view of the sheet. Prove that the magnetic field near the sheet is parallel to the sheet and perpendicular to the current direction, with magnitude $\mu_0 J_s / 2$.

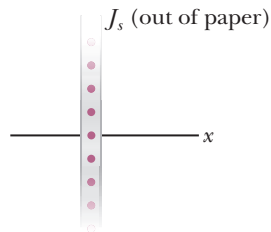

Figure P30.34

35. The magnetic field 40.0 cm away from a long, straight wire carrying current 2.00 A is $1.00 \mu\text{T}$. (a) At what distance is it $0.100 \mu\text{T}$? (b) **What If?** At one instant, the two conductors in a long household extension cord carry equal 2.00-A currents in opposite directions. The two wires are 3.00 mm apart. Find the magnetic field 40.0 cm away from the middle of the straight cord, in the plane of the two wires. (c) At what distance is it one-tenth as large? (d) The center wire in a coaxial cable carries current 2.00 A in one direction, and the sheath around it carries current 2.00 A in the opposite direction. What magnetic field does the cable create at points outside the cable?
36. A packed bundle of 100 long, straight, insulated wires forms a cylinder of radius $R = 0.500 \text{ cm}$. If each wire carries 2.00 A , what are (a) the magnitude and (b) the direction of the magnetic force per unit length acting on a wire located 0.200 cm from the center of the bundle? (c) **What If?** Would a wire on the outer edge of the bundle experience a force greater or smaller than the value calculated in parts (a) and (b)? Give a qualitative argument for your answer.
37. The magnetic field created by a large current passing through plasma (ionized gas) can force current-carrying particles together. This *pinch effect* has been used in designing fusion reactors. It can be demonstrated by making an empty aluminum can carry a large current parallel to its axis. Let R represent the radius of the can and I the current, uniformly distributed over the can's curved wall. Determine the magnetic field (a) just inside the wall and (b) just outside. (c) Determine the pressure on the wall.

38. A long, cylindrical conductor of radius R carries a current I as shown in Figure P30.38. The current density J , however, is not uniform over the cross section of the conductor but rather is a function of the radius according to $J = br$, where b is a constant. Find an expression for the magnetic field magnitude B (a) at a distance $r_1 < R$ and (b) at a distance $r_2 > R$, measured from the center of the conductor.

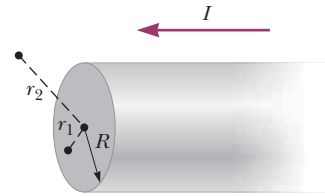

Figure P30.38

39. Four long, parallel conductors carry equal currents of $I = 5.00 \text{ A}$. Figure P30.39 is an end view of the conductors. The current direction is into the page at points A and B and out of the page at points C and D . Calculate (a) the magnitude and (b) the direction of the magnetic field at point P , located at the center of the square of edge length $\ell = 0.200 \text{ m}$.

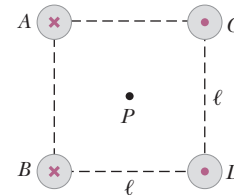

Figure P30.39

Section 30.4 The Magnetic Field of a Solenoid

40. A certain superconducting magnet in the form of a solenoid of length 0.500 m can generate a magnetic field of 9.00 T in its core when its coils carry a current of 75.0 A . Find the number of turns in the solenoid.
41. A long solenoid that has $1\,000$ turns uniformly distributed over a length of 0.400 m produces a magnetic field of magnitude $1.00 \times 10^{-4} \text{ T}$ at its center. What current is required in the windings for that to occur?
42. You are given a certain volume of copper from which you can make copper wire. To insulate the wire, you can have as much enamel as you like. You will use the wire to make a tightly wound solenoid 20 cm long having the greatest possible magnetic field at the center and using a power supply that can deliver a current of 5 A . The solenoid can be wrapped with wire in one or more layers. (a) Should you make the wire long and thin or shorter and thick? Explain. (b) Should you make the radius of the solenoid small or large? Explain.
43. A single-turn square loop of wire, 2.00 cm on each edge, carries a clockwise current of 0.200 A . The loop is inside a solenoid, with the plane of the loop perpendicular to the magnetic field of the solenoid. The solenoid has

30.0 turns/cm and carries a clockwise current of 15.0 A. Find (a) the force on each side of the loop and (b) the torque acting on the loop.

44. A solenoid 10.0 cm in diameter and 75.0 cm long is made from copper wire of diameter 0.100 cm, with very thin insulation. The wire is wound onto a cardboard tube in a single layer, with adjacent turns touching each other. What power must be delivered to the solenoid if it is to produce a field of 8.00 mT at its center?
45. It is desired to construct a solenoid that will have a resistance of 5.00Ω (at 20.0°C) and produce a magnetic field of $4.00 \times 10^{-2} \text{ T}$ at its center when it carries a current of 4.00 A. The solenoid is to be constructed from copper wire having a diameter of 0.500 mm. If the radius of the solenoid is to be 1.00 cm, determine (a) the number of turns of wire needed and (b) the required length of the solenoid.

Section 30.5 Gauss's Law in Magnetism

46. Consider the hemispherical closed surface in Figure P30.46. The hemisphere is in a uniform magnetic field that makes an angle θ with the vertical. Calculate the magnetic flux through (a) the flat surface S_1 and (b) the hemispherical surface S_2 .

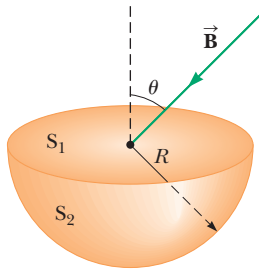

Figure P30.46

47. A cube of edge length $\ell = 2.50 \text{ cm}$ is positioned as shown in Figure P30.47. A uniform magnetic field given by $\vec{B} = (5\hat{i} + 4\hat{j} + 3\hat{k}) \text{ T}$ exists throughout the region. (a) Calculate the magnetic flux through the shaded face. (b) What is the total flux through the six faces?

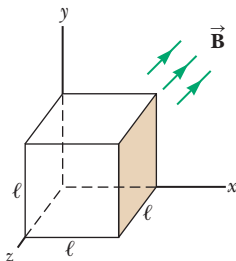

Figure P30.47

48. A solenoid of radius $r = 1.25 \text{ cm}$ and length $\ell = 30.0 \text{ cm}$ has 300 turns and carries 12.0 A. (a) Calculate the flux through the surface of a disk-shaped area of radius $R = 5.00 \text{ cm}$ that is positioned perpendicular to and centered on the axis of the solenoid as

shown in Figure P30.48a. (b) Figure P30.48b shows an enlarged end view of the same solenoid. Calculate the flux through the tan area, which is an annulus with an inner radius of $a = 0.400 \text{ cm}$ and an outer radius of $b = 0.800 \text{ cm}$.

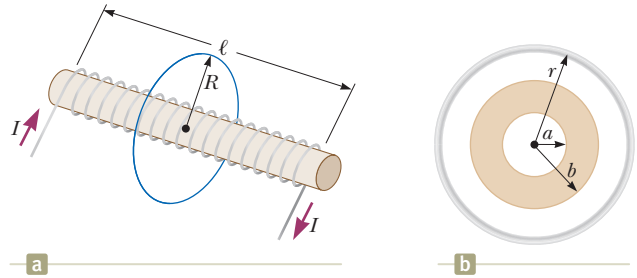

Figure P30.48

Section 30.6 Magnetism in Matter

49. The magnetic moment of the Earth is approximately $8.00 \times 10^{22} \text{ A}\cdot\text{m}^2$. Imagine that the planetary magnetic field were caused by the complete magnetization of a huge iron deposit with density $7\,900 \text{ kg/m}^3$ and approximately 8.50×10^{28} iron atoms/ m^3 . (a) How many unpaired electrons, each with a magnetic moment of $9.27 \times 10^{-24} \text{ A}\cdot\text{m}^2$, would participate? (b) At two unpaired electrons per iron atom, how many kilograms of iron would be present in the deposit?
50. At saturation, when nearly all the atoms have their magnetic moments aligned, the magnetic field is equal to the permeability constant μ_0 multiplied by the magnetic moment per unit volume. In a sample of iron, where the number density of atoms is approximately 8.50×10^{28} atoms/ m^3 , the magnetic field can reach 2.00 T. If each electron contributes a magnetic moment of $9.27 \times 10^{-24} \text{ A}\cdot\text{m}^2$ (1 Bohr magneton), how many electrons per atom contribute to the saturated field of iron?

Additional Problems

51. A 30.0-turn solenoid of length 6.00 cm produces a magnetic field of magnitude 2.00 mT at its center. Find the current in the solenoid.
52. A wire carries a 7.00-A current along the x axis, and another wire carries a 6.00-A current along the y axis, as shown in Figure P30.52. What is the magnetic field at point P , located at $x = 4.00 \text{ m}$, $y = 3.00 \text{ m}$?

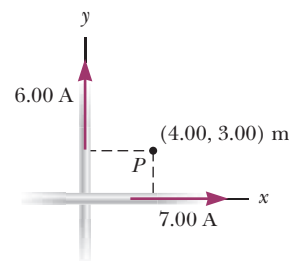

Figure P30.52

53. Suppose you install a compass on the center of a car's dashboard. (a) Assuming the dashboard is made mostly of plastic, compute an order-of-magnitude estimate for the magnetic field at this location produced by the current when you switch on the car's headlights. (b) How does this estimate compare with the Earth's magnetic field?
54. *Why is the following situation impossible?* The magnitude of the Earth's magnetic field at either pole is approximately 7.00×10^{-5} T. Suppose the field fades away to zero before its next reversal. Several scientists propose plans for artificially generating a replacement magnetic field to assist with devices that depend on the presence of the field. The plan that is selected is to lay a copper wire around the equator and supply it with a current that would generate a magnetic field of magnitude 7.00×10^{-5} T at the poles. (Ignore magnetization of any materials inside the Earth.) The plan is implemented and is highly successful.
55. **M** A nonconducting ring of radius 10.0 cm is uniformly charged with a total positive charge $10.0 \mu\text{C}$. The ring rotates at a constant angular speed 20.0 rad/s about an axis through its center, perpendicular to the plane of the ring. What is the magnitude of the magnetic field on the axis of the ring 5.00 cm from its center?
56. A nonconducting ring of radius R is uniformly charged with a total positive charge q . The ring rotates at a constant angular speed ω about an axis through its center, perpendicular to the plane of the ring. What is the magnitude of the magnetic field on the axis of the ring a distance $\frac{1}{2}R$ from its center?
57. A very long, thin strip of metal of width w carries a current I along its length as shown in Figure P30.57. The current is distributed uniformly across the width of the strip. Find the magnetic field at point P in the diagram. Point P is in the plane of the strip at distance b away from its edge.

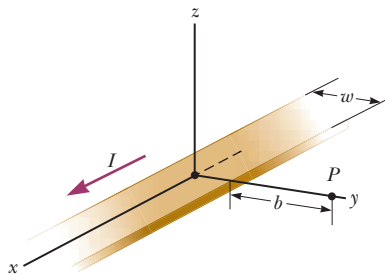

Figure P30.57

58. A circular coil of five turns and a diameter of 30.0 cm is oriented in a vertical plane with its axis perpendicular to the horizontal component of the Earth's magnetic field. A horizontal compass placed at the coil's center is made to deflect 45.0° from magnetic north by a current of 0.600 A in the coil. (a) What is the horizontal component of the Earth's magnetic field? (b) The current in the coil is switched off. A "dip

needle" is a magnetic compass mounted so that it can rotate in a vertical north-south plane. At this location, a dip needle makes an angle of 13.0° from the vertical. What is the total magnitude of the Earth's magnetic field at this location?

59. A very large parallel-plate capacitor has uniform charge per unit area $+\sigma$ on the upper plate and $-\sigma$ on the lower plate. The plates are horizontal, and both move horizontally with speed v to the right. (a) What is the magnetic field between the plates? (b) What is the magnetic field just above or just below the plates? (c) What are the magnitude and direction of the magnetic force per unit area on the upper plate? (d) At what extrapolated speed v will the magnetic force on a plate balance the electric force on the plate? *Suggestion:* Use Ampere's law and choose a path that closes between the plates of the capacitor.
60. Two circular coils of radius R , each with N turns, are perpendicular to a common axis. The coil centers are a distance R apart. Each coil carries a steady current I in the same direction as shown in Figure P30.60. (a) Show that the magnetic field on the axis at a distance x from the center of one coil is

$$B = \frac{N\mu_0 I R^2}{2} \left[\frac{1}{(R^2 + x^2)^{3/2}} + \frac{1}{(2R^2 + x^2 - 2Rx)^{3/2}} \right]$$

(b) Show that dB/dx and d^2B/dx^2 are both zero at the point midway between the coils. We may then conclude that the magnetic field in the region midway between the coils is uniform. Coils in this configuration are called *Helmholtz coils*.

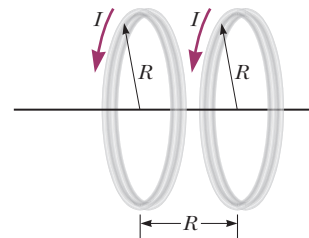

Figure P30.60 Problems 60 and 61.

61. Two identical, flat, circular coils of wire each have 100 turns and radius $R = 0.500$ m. The coils are arranged as a set of Helmholtz coils so that the separation distance between the coils is equal to the radius of the coils (see Fig. P30.60). Each coil carries current $I = 10.0$ A. Determine the magnitude of the magnetic field at a point on the common axis of the coils and halfway between them.
62. **AMT** Two circular loops are parallel, coaxial, and almost in contact, with their centers 1.00 mm apart (Fig. P30.62, page 932). Each loop is 10.0 cm in radius. The top loop carries a clockwise current of $I = 140$ A. The bottom loop carries a counterclockwise current of $I = 140$ A. (a) Calculate the magnetic force exerted by the bottom loop on the top loop. (b) Suppose a student thinks the first step in solving part (a) is to use Equation 30.7 to find the magnetic field created by one of the loops.

How would you argue for or against this idea? (c) The upper loop has a mass of 0.0210 kg . Calculate its acceleration, assuming the only forces acting on it are the force in part (a) and the gravitational force.

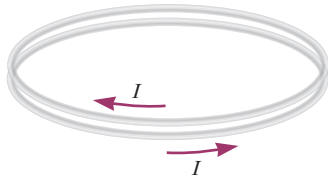

Figure P30.62

63. Two long, straight wires cross each other perpendicularly as shown in Figure P30.63. The wires are thin so that they are effectively in the same plane but do not touch. Find the magnetic field at a point 30.0 cm above the point of intersection of the wires along the z axis; that is, 30.0 cm out of the page, toward you.

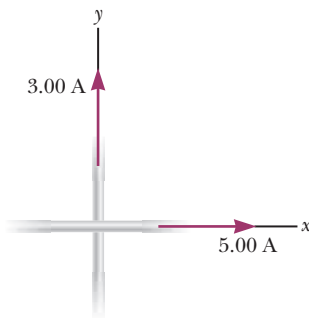

Figure P30.63

64. Two coplanar and concentric circular loops of wire carry currents of $I_1 = 5.00 \text{ A}$ and $I_2 = 3.00 \text{ A}$ in opposite directions as in Figure P30.64. If $r_1 = 12.0 \text{ cm}$ and $r_2 = 9.00 \text{ cm}$, what are (a) the magnitude and (b) the direction of the net magnetic field at the center of the two loops? (c) Let r_1 remain fixed at 12.0 cm and let r_2 be a variable. Determine the value of r_2 such that the net field at the center of the loops is zero.

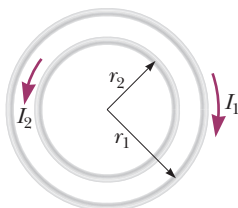

Figure P30.64

65. As seen in previous chapters, any object with electric charge, stationary or moving, other than the charged object that created the field, experiences a force in an electric field. Also, any object with electric charge, stationary or moving, can create an electric field (Chapter 23). Similarly, an electric current or a moving electric charge, other than the current or charge that created the field, experiences a force in a magnetic field (Chapter 29), and an electric current cre-

ates a magnetic field (Section 30.1). (a) To understand how a moving charge can also create a magnetic field, consider a particle with charge q moving with velocity \vec{v} . Define the position vector $\vec{r} = r\hat{r}$ leading from the particle to some location. Show that the magnetic field at that location is

$$\vec{B} = \frac{\mu_0}{4\pi} \frac{q\vec{v} \times \hat{r}}{r^2}$$

- (b) Find the magnitude of the magnetic field 1.00 mm to the side of a proton moving at $2.00 \times 10^7 \text{ m/s}$. (c) Find the magnetic force on a second proton at this point, moving with the same speed in the opposite direction. (d) Find the electric force on the second proton.

66. **Review.** Rail guns have been suggested for launching projectiles into space without chemical rockets. **AMT** A tabletop model rail gun (Fig. P30.66) consists of two long, parallel, horizontal rails $\ell = 3.50 \text{ cm}$ apart, bridged by a bar of mass $m = 3.00 \text{ g}$ that is free to slide without friction. The rails and bar have low electric resistance, and the current is limited to a constant $I = 24.0 \text{ A}$ by a power supply that is far to the left of the figure, so it has no magnetic effect on the bar. Figure P30.66 shows the bar at rest at the midpoint of the rails at the moment the current is established. We wish to find the speed with which the bar leaves the rails after being released from the midpoint of the rails. (a) Find the magnitude of the magnetic field at a distance of 1.75 cm from a single long wire carrying a current of 2.40 A . (b) For purposes of evaluating the magnetic field, model the rails as infinitely long. Using the result of part (a), find the magnitude and direction of the magnetic field at the midpoint of the bar. (c) Argue that this value of the field will be the same at all positions of the bar to the right of the midpoint of the rails. At other points along the bar, the field is in the same direction as at the midpoint, but is larger in magnitude. Assume the average effective magnetic field along the bar is five times larger than the field at the midpoint. With this assumption, find (d) the magnitude and (e) the direction of the force on the bar. (f) Is the bar properly modeled as a particle under constant acceleration? (g) Find the velocity of the bar after it has traveled a distance $d = 130 \text{ cm}$ to the end of the rails.

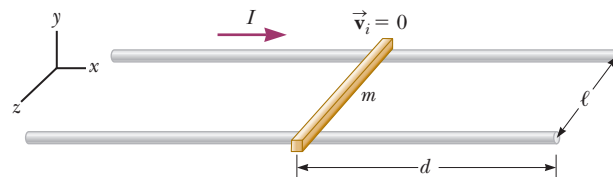

Figure P30.66

67. Fifty turns of insulated wire 0.100 cm in diameter are tightly wound to form a flat spiral. The spiral fills a disk surrounding a circle of radius 5.00 cm and extending to a radius 10.00 cm at the outer edge. Assume the wire carries a current I at the center of its cross section. Approximate each turn of wire as a circle. Then a loop

of current exists at radius 5.05 cm, another at 5.15 cm, and so on. Numerically calculate the magnetic field at the center of the coil.

68. An infinitely long, straight wire carrying a current I_1 is partially surrounded by a loop as shown in Figure P30.68. The loop has a length L and radius R , and it carries a current I_2 . The axis of the loop coincides with the wire. Calculate the magnetic force exerted on the loop.

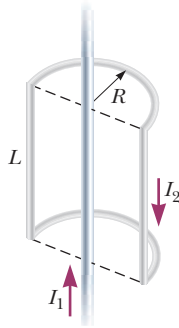

Figure P30.68

Challenge Problems

69. Consider a solenoid of length ℓ and radius a containing N closely spaced turns and carrying a steady current I . (a) In terms of these parameters, find the magnetic field at a point along the axis as a function of position x from the end of the solenoid. (b) Show that as ℓ becomes very long, B approaches $\mu_0 NI/2\ell$ at each end of the solenoid.
70. We have seen that a long solenoid produces a uniform magnetic field directed along the axis of a cylindrical region. To produce a uniform magnetic field directed parallel to a *diameter* of a cylindrical region, however, one can use the *saddle coils* illustrated in Figure P30.70. The loops are wrapped over a long, somewhat flattened tube. Figure P30.70a shows one wrapping of wire around the tube. This wrapping is continued in this manner until the visible side has many long sections of wire carrying current to the left in Figure P30.70a and the back side has many lengths carrying current to

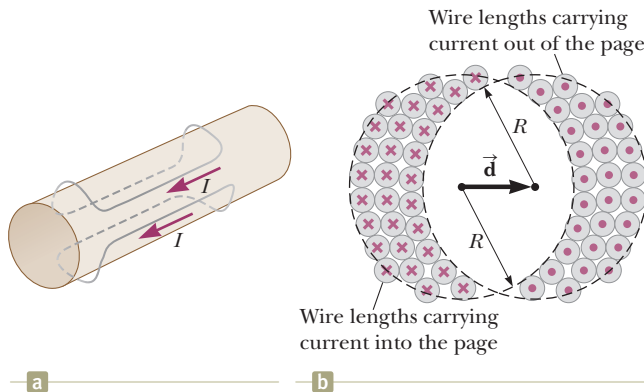

Figure P30.70

the right. The end view of the tube in Figure P30.70b shows these wires and the currents they carry. By wrapping the wires carefully, the distribution of wires can take the shape suggested in the end view such that the overall current distribution is approximately the superposition of two overlapping, circular cylinders of radius R (shown by the dashed lines) with uniformly distributed current, one toward you and one away from you. The current density J is the same for each cylinder. The center of one cylinder is described by a position vector \vec{d} relative to the center of the other cylinder. Prove that the magnetic field inside the hollow tube is $\mu_0 Jd/2$ downward. *Suggestion:* The use of vector methods simplifies the calculation.

71. A thin copper bar of length $\ell = 10.0$ cm is supported horizontally by two (nonmagnetic) contacts at its ends. The bar carries a current of $I_1 = 100$ A in the negative x direction as shown in Figure P30.71. At a distance $h = 0.500$ cm below one end of the bar, a long, straight wire carries a current of $I_2 = 200$ A in the positive z direction. Determine the magnetic force exerted on the bar.

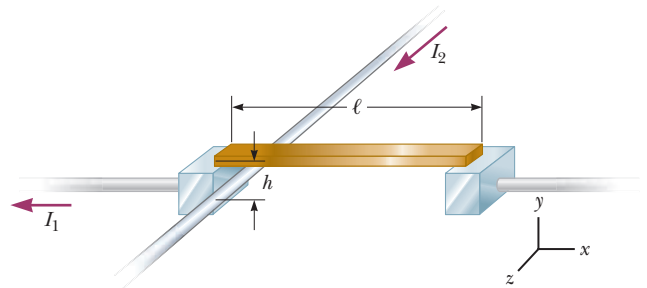

Figure P30.71

72. In Figure P30.72, both currents in the infinitely long wires are 8.00 A in the negative x direction. The wires are separated by the distance $2a = 6.00$ cm. (a) Sketch the magnetic field pattern in the yz plane. (b) What is the value of the magnetic field at the origin? (c) At $(y = 0, z \rightarrow \infty)$? (d) Find the magnetic field at points along the z axis as a function of z . (e) At what distance d along the positive z axis is the magnetic field a maximum? (f) What is this maximum value?

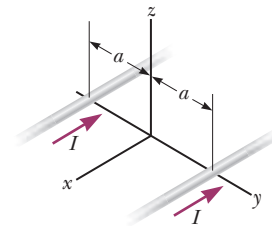

Figure P30.72

73. A wire carrying a current I is bent into the shape of an exponential spiral, $r = e^\theta$, from $\theta = 0$ to $\theta = 2\pi$ as suggested in Figure P30.73 (page 934). To complete a loop, the ends of the spiral are connected by a straight wire along the x axis. (a) The angle β between a radial

line and its tangent line at any point on a curve $r = f(\theta)$ is related to the function by

$$\tan \beta = \frac{r}{dr/d\theta}$$

Use this fact to show that $\beta = \pi/4$. (b) Find the magnetic field at the origin.

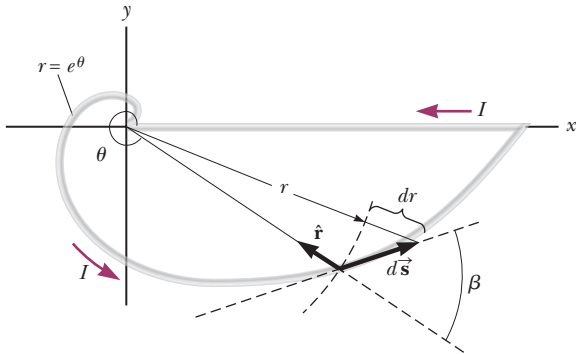

Figure P30.73

74. A sphere of radius R has a uniform volume charge density ρ . When the sphere rotates as a rigid object with angular speed ω about an axis through its center (Fig. P30.74), determine (a) the magnetic field at the center of the sphere and (b) the magnetic moment of the sphere.

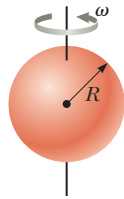

Figure P30.74

75. A long, cylindrical conductor of radius a has two cylindrical cavities each of diameter a through its entire length as shown in the end view of Figure P30.75. A current I is directed out of the page and is uniform through a cross section of the conducting material. Find the magnitude and direction of the magnetic field in terms of μ_0 , I , r , and a at (a) point P_1 and (b) point P_2 .

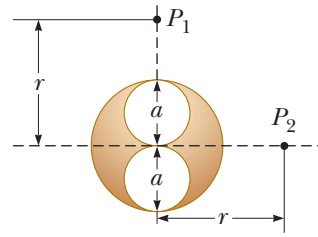

Figure P30.75

76. A wire is formed into the shape of a square of edge length L (Fig. P30.76). Show that when the current in the loop is I , the magnetic field at point P a distance x from the center of the square along its axis is

$$B = \frac{\mu_0 I L^2}{2\pi(x^2 + L^2/4)\sqrt{x^2 + L^2/2}}$$

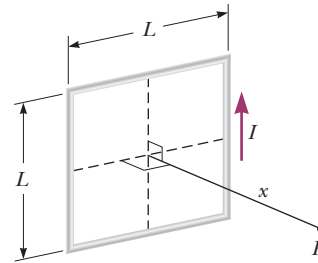

Figure P30.76

77. The magnitude of the force on a magnetic dipole $\vec{\mu}$ aligned with a nonuniform magnetic field in the positive x direction is $F_x = |\vec{\mu}| dB/dx$. Suppose two flat loops of wire each have radius R and carry a current I . (a) The loops are parallel to each other and share the same axis. They are separated by a variable distance $x \gg R$. Show that the magnetic force between them varies as $1/x^4$. (b) Find the magnitude of this force, taking $I = 10.0$ A, $R = 0.500$ cm, and $x = 5.00$ cm.