

ملاحظة مهمة جداً جداً جداً : هذا الريبورت وغيره ليس للنقل الحرفي ..  
هو مجرد وسيلة للمساعدة وأخذ الأفكار حول الطريقة الصحيحة لكتابة ريبورت  
( غير هيك مبروك عليكم علامة الصفر .. اللهم بلغت اللهم فاشهد )

**Done by sandy ghassan & haneen al assaf**

#### <<Experiment 4 >>

#### **Objectives :**

The objective of this experiment is to simplify resistive circuits in DC employing the Thevenin and Norton equivalents. Experimental results will allow the verification of the theoretical analysis. Also to verify the maximum power transfer theorem, this will lead us to learn about some types of variable resistors such as decade resistance box and potentiometers.

---

#### **Theory :**

##### **1- Thevenin's Theorem**

Any linear network may, with respect to a pair of terminals. be replaced by an

equivalent voltage source  $V_{th}$  ( equal to the open circuit voltage) in series with a resistance  $R_{th}$  seen between these terminals. The theorem presents a very useful method for simplifying complex circuits. We must realize that the equivalency is with respect to a selected pair of terminals. We replace the original circuit lying on one side of a pair of terminals by its equivalent Thevenin voltage source and resistance.

## **2-Norton's Theorem**

Any linear network may, with respect to a pair of terminals, be replaced by a current source  $I_N$  (equal to the short- circuit current) in parallel with the resistance  $R_{th}$  seen between the two terminals. Similar to Thevenin's Theorem, we are presented with a simple method of reducing a more complex circuit to a simpler one. The difference lies in converting the reduced circuit to a current source instead of a voltage source, with the equivalent resistance in parallel rather than in series.

## **3-Maximum Power Transfer Theory**

An independent voltage source in series with a resistance  $R_{th}$ , or an independent

current source in parallel with a resistance  $R_{th}$ , delivers maximum power to a load resistance  $R_L$  when  $R_{th} = R_L$  .

The maximum power delivered, in this case, is

$$P(max) = \frac{V_{th}^2}{4R_{th}}$$

## **4- Variable resistors :**

In addition to fixed- value resistors – which we dealt with in the previous three experiments- variable resistors, are used extensively in electrical and electronic circuits. The two types of variable resistors are rheostat and the potentiometer. A rheostat is essentially a two terminal device. Its circuit symbol is shown in below. Points A and B connect in to the circuit. A rheostat has a maximum resistance value, specified by the manufacturer, and a minimum value, usually  $0 \Omega$ , The arrowhead in the figure indicates a mechanical means of adjusting the rheostat so that the resistance, measured between points A and B, can be adjusted to any intermediate value within the range of variation.

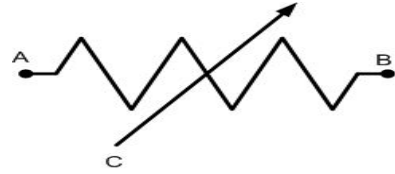

A Rheostat is a variable resistor with two terminals

The circuit symbol for a potentiometer below, shows that this is a three-terminal device. The resistance between points A and B is fixed. Point C is the variable arm of the potentiometer. The arm is a metal contactor that slides along the un-insulated surface of the resistance element. The amount of resistance material between the point of contact and one of the end terminals determines the resistance between those two points. Thus the longer the surface between points A and C, the greater is the resistance between these two points. In other words, the resistance between points A and C varies as the length of the element included between points A and C. The same is true for points B and C. The resistance  $R_{AC}$

from A to C plus the resistance  $R_{CB}$  from C to B make up the fixed resistance  $R_{AB}$  of the potentiometer. The action of the arm is to increase the resistance between C and one of the end terminals and at the same time to decrease the resistance between C and the other terminal while the sum of the two resistances  $R_{AC}$  and  $R_{CB}$  remains constant.

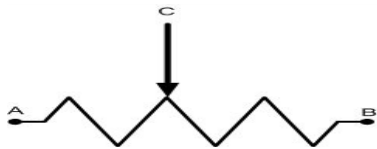

A potentiometer

---

### Equipment :

- Breadboard
  - Digital Multimeter (DMM )
  - Power Supply
  - resistors
  - Potentiometer
  - wires
-

## Procedure :

1. First We will build the circuit as shown in the figure
2. Let open circuit instead RL and connect the DMM as a voltmeter to measure Vth
3. We put the red wire onto the black in the power supply to make a short circuit then we connect DMM as an ohmmeter to measure Rth

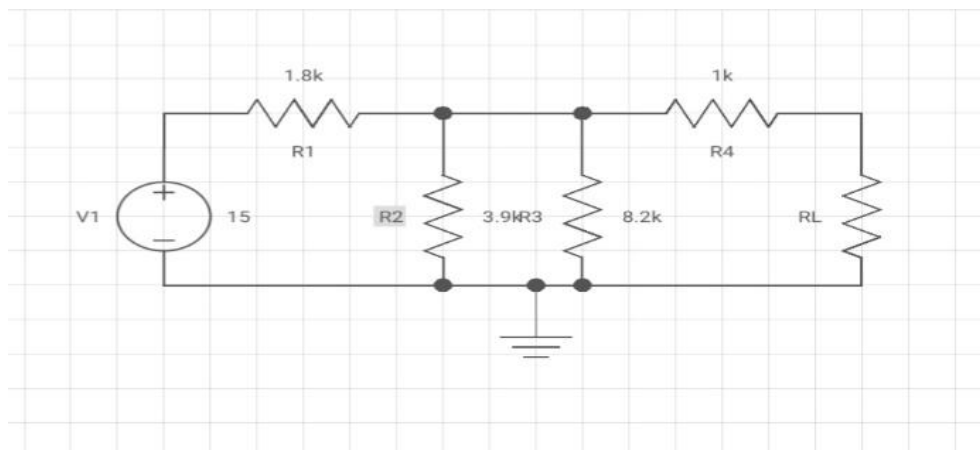

There are some calculations we have done in this experiment

parameter	Vth	IN	Rth
Measured	<b>8.93 V</b>		<b>6.16 k</b>
Theoretical	<b>8.923 V</b>	<b>1.445 mA</b>	<b>6.17 k</b>

**First we will make o.c instead RL to calculate Vth**

Then we will find R23

$$**R_{23} = 3.9 * 8.2 / (3.9 + 8.2) = 2.64 \text{ K}\Omega$$

$$**R_{eq} = 2.64 + 1.8 = 4.44 \text{ k}\Omega$$

$$**I_s = V_s / R_{eq} = 15 / 4.44 = 3.38 \text{ mA}$$

$$**V_{th} = R_{23} * I_s = 3.38 * 2.64 = 8.923 \text{ V}$$

**Then we will make s.c instead RL to calculate IN**

$$**I_N = V_{th} / R_{th} = 8.923 / 6.17 = 1.4457 \text{ mA}$$

**Finally we will make s.c instead voltage source to calculate Rth**

$$R_{th} = (R_1 // R_{23}) + R_4$$

$$**R_{th} = (2.64 * 1.8 / 4.44) + 5.1 = 6.17 \text{ k}\Omega$$

---

**NOW, we will use A potentiometer in this part**

put the variable resistor on a value of 3 K $\Omega$  by measuring it in DMM and then we will measure the voltage on it. And the same on 6,9 k $\Omega$

RL K $\Omega$	VL	PL
3 K $\Omega$	2.96 V	2.921 mW
6 K $\Omega$	4.42 V	3.25 mW
8.7 K $\Omega$	5.24 V	3.15 mW

**There are some calculations we have done in this experiment**

$$P_l = v_l^2 / R_{th}$$

$$P_{l3} = 2.96^2 / 3 = 2.921 \text{ mW}$$

$$P_{l6} = 4.42^2 / 6 = 3.25 \text{ mW} \quad \text{and,} \quad P_{l8.7} = 5.24^2 / 8.7 = 3.15 \text{ mW}$$

Now we will solve the questions

1. Draw the power consumed by the load

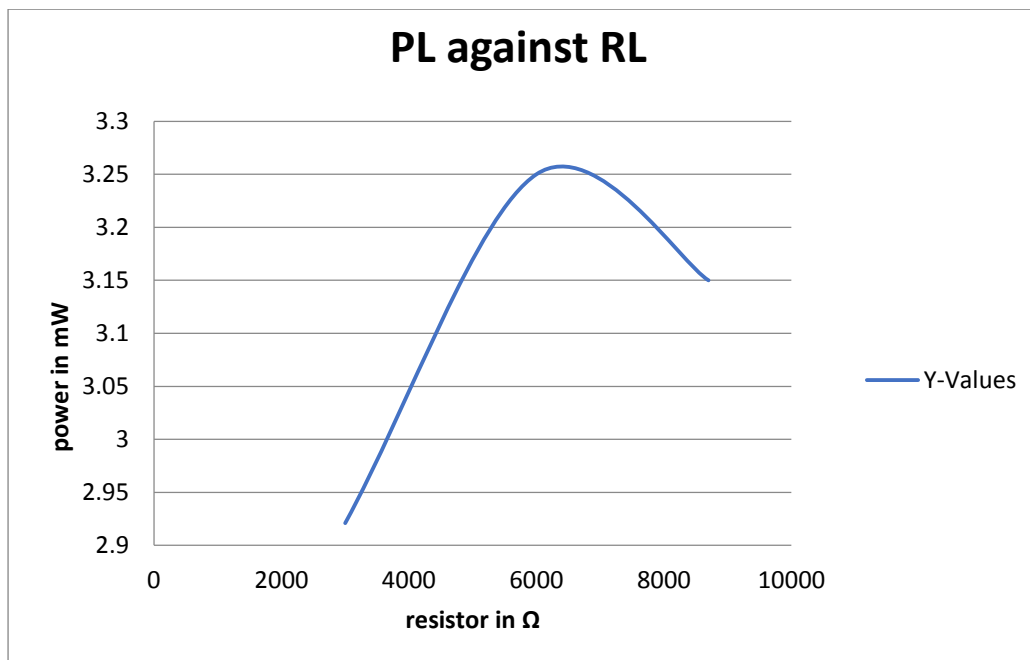

2. Draw the THEVENIN equivalent circuit

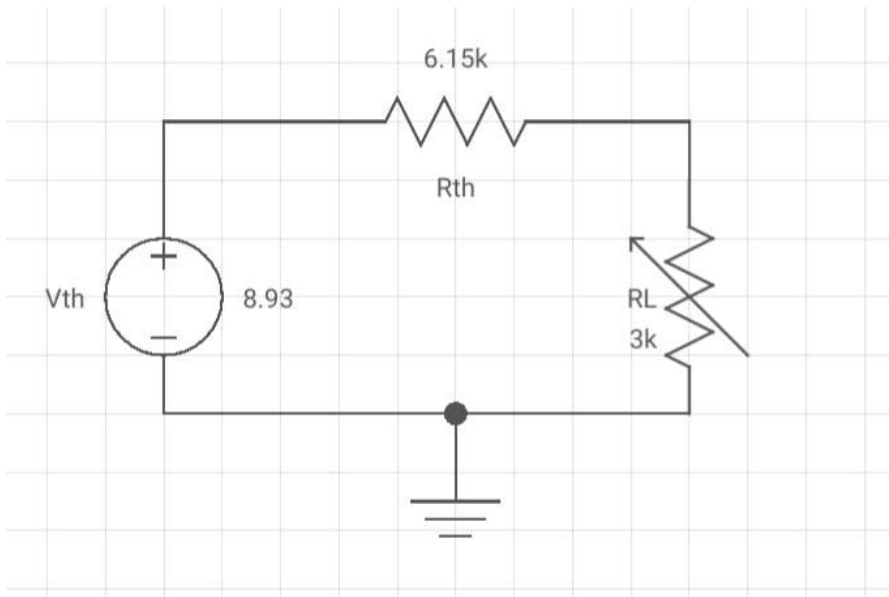

**3. Draw the NORTON equivalent circuit**

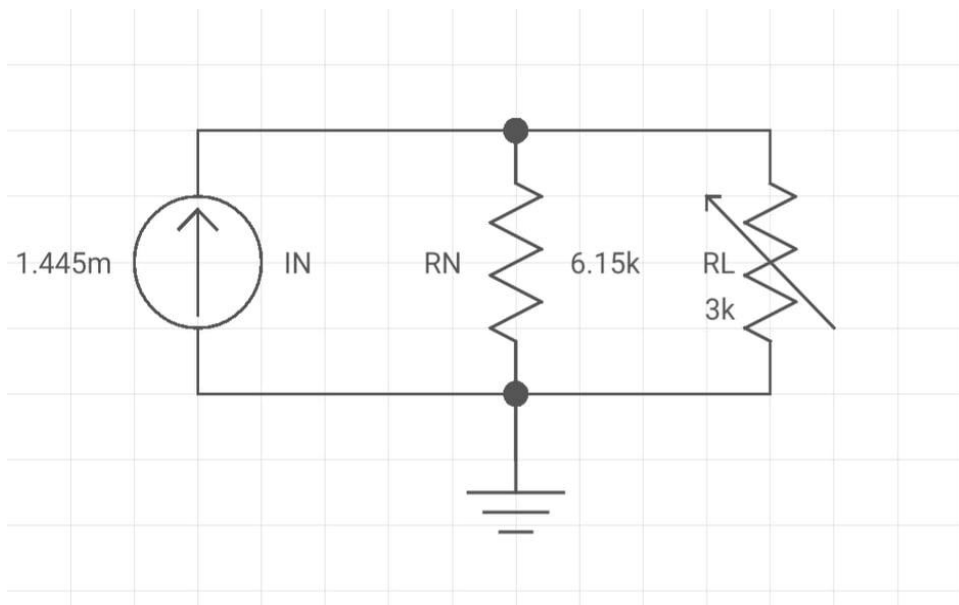

**4. Determine which resistor consumes the largest power from the second table**

The  $R_L$  with the largest power is 6 k $\Omega$  ( $p = 3.25$  mW)

5. Is this formula  $p_{max} = \frac{V_{th}^2}{4 R_{th}}$  verified the maximum power calculated from your measurements ? if yes , prove that .

Yes , the value is so close

$$P_{\max} = 8.93^2 / 4 * 6.17 = 3.226 \text{ Ma}$$

---